



Chipsmall Limited consists of a professional team with an average of over 10 year of expertise in the distribution of electronic components. Based in Hongkong, we have already established firm and mutual-benefit business relationships with customers from,Europe,America and south Asia,supplying obsolete and hard-to-find components to meet their specific needs.

With the principle of “Quality Parts,Customers Priority,Honest Operation,and Considerate Service”,our business mainly focus on the distribution of electronic components. Line cards we deal with include Microchip,ALPS,ROHM,Xilinx,Pulse,ON,Everlight and Freescale. Main products comprise IC,Modules,Potentiometer,IC Socket,Relay,Connector.Our parts cover such applications as commercial,industrial, and automotives areas.

We are looking forward to setting up business relationship with you and hope to provide you with the best service and solution. Let us make a better world for our industry!



Contact us

Tel: +86-755-8981 8866 Fax: +86-755-8427 6832

Email & Skype: info@chipsmall.com Web: www.chipsmall.com

Address: A1208, Overseas Decoration Building, #122 Zhenhua RD., Futian, Shenzhen, China



Absolute maximum ratings

($T_a=25^\circ\text{C}$)

Symbol	Ratings		Unit
	NPN	PNP	
V_{CBO}	60	-60	V
V_{CEO}	60	-60	V
V_{EBO}	6	-6	V
I_C	4	-4	A
I_{CP}	8 (PW \leq 10ms, Du \leq 50%)	-8 (PW \leq 10ms, Du \leq 50%)	A
P_T	4 ($T_a=25^\circ\text{C}$)		W
	20 ($T_c=25^\circ\text{C}$)		
T_j	150		$^\circ\text{C}$
T_{stg}	-40 to +150		$^\circ\text{C}$

Equivalent circuit diagram

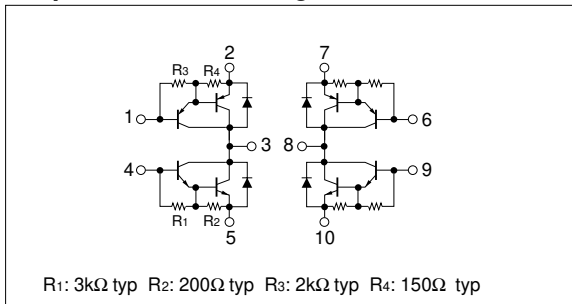

Characteristic curves

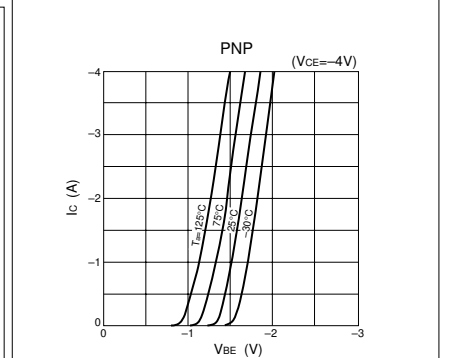
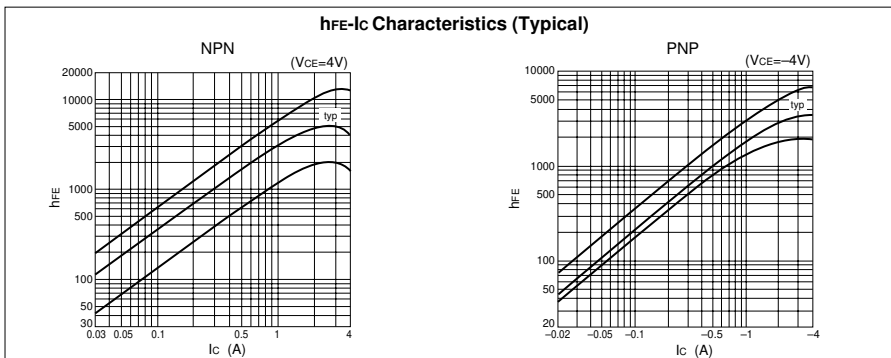
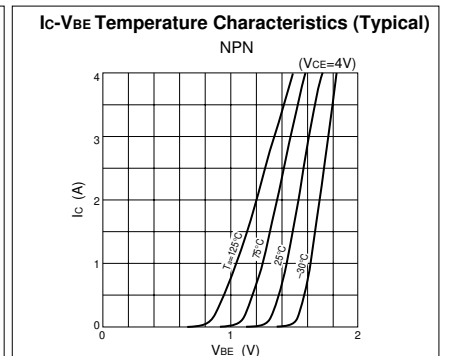
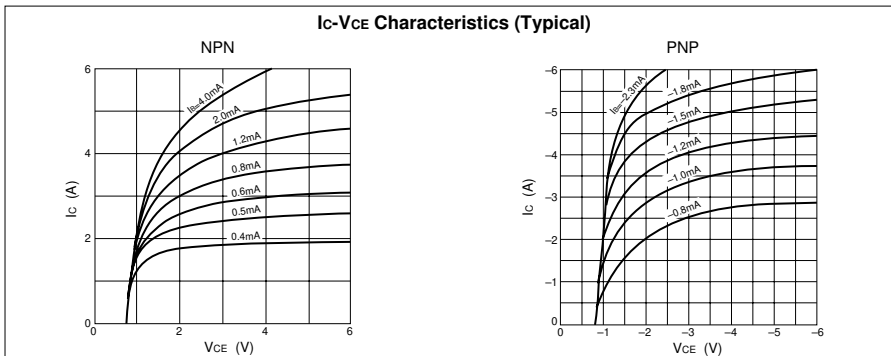

Electrical characteristics

($T_a=25^\circ\text{C}$)

Symbol	NPN					PNP				
	Specification			Unit	Conditions	Specification			Unit	Conditions
	min	typ	max			min	typ	max		
I_{CBO}			10	μA	$V_{CB}=60\text{V}$			-10	μA	$V_{CB}=-60\text{V}$
I_{EBO}			10	mA	$V_{EB}=6\text{V}$			-10	mA	$V_{EB}=-6\text{V}$
V_{CEO}	60			V	$I_C=10\text{mA}$	-60			V	$I_C=-10\text{mA}$
h_{FE}	2000				$V_{CE}=4\text{V}, I_C=2\text{A}$	2000				$V_{CE}=-4\text{V}, I_C=-2\text{A}$
$V_{CE(sat)}$			1.5	V	$I_C=2\text{A}, I_B=4\text{mA}$			-1.5	V	$I_C=-2\text{A}, I_B=-4\text{mA}$
$V_{BE(sat)}$			2.0	V				-2.0	V	
V_{FEC}			1.6	V	$I_{FEC}=2\text{A}$			-1.6	V	$I_{FEC}=-2\text{A}$

Characteristic curves

