



Chipsmall Limited consists of a professional team with an average of over 10 year of expertise in the distribution of electronic components. Based in Hongkong, we have already established firm and mutual-benefit business relationships with customers from,Europe,America and south Asia,supplying obsolete and hard-to-find components to meet their specific needs.

With the principle of "Quality Parts,Customers Priority,Honest Operation,and Considerate Service",our business mainly focus on the distribution of electronic components. Line cards we deal with include Microchip,ALPS,ROHM,Xilinx,Pulse,ON,Everlight and Freescale. Main products comprise IC,Modules,Potentiometer,IC Socket,Relay,Connector.Our parts cover such applications as commercial,industrial, and automotives areas.

We are looking forward to setting up business relationship with you and hope to provide you with the best service and solution. Let us make a better world for our industry!



Contact us

Tel: +86-755-8981 8866 Fax: +86-755-8427 6832

Email & Skype: info@chipsmall.com Web: www.chipsmall.com

Address: A1208, Overseas Decoration Building, #122 Zhenhua RD., Futian, Shenzhen, China





30V 3.5A QUAD POWER HALF BRIDGE

- MINIMUM INPUT OUTPUT PULSE WIDTH DISTORTION
- 200mΩ R_{dsON} COMPLEMENTARY DMOS OUTPUT STAGE
- CMOS COMPATIBLE LOGIC INPUTS
- THERMAL PROTECTION
- THERMAL WARNING OUTPUT
- OVERVOLTAGE, UNDERVOLTAGE PROTECTION

MULTIPOWER BCD TECHNOLOGY

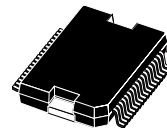

PowerSO36

ORDERING NUMBER: STA500

DESCRIPTION

STA500 is a monolithic quad half bridge stage in Multipower BCD Technology. The device can be used as dual bridge or reconfigured, by connecting CONFIG pin to V_{DD} pin, as single bridge with double current capability, and as half bridge (Binary mode) with half

current capability.

The device is particularly designed to make the output stage of a stereo All-Digital High Efficiency (DDX™) amplifier capable to deliver 30W + 30W output power on 8Ω load and 60W on 8Ω load in bridge BTL configuration or more 60W on 4Ω load. The input pins have threshold proportional to I_{bias} pin voltage.

AUDIO APPLICATION CIRCUIT (Dual BTL)

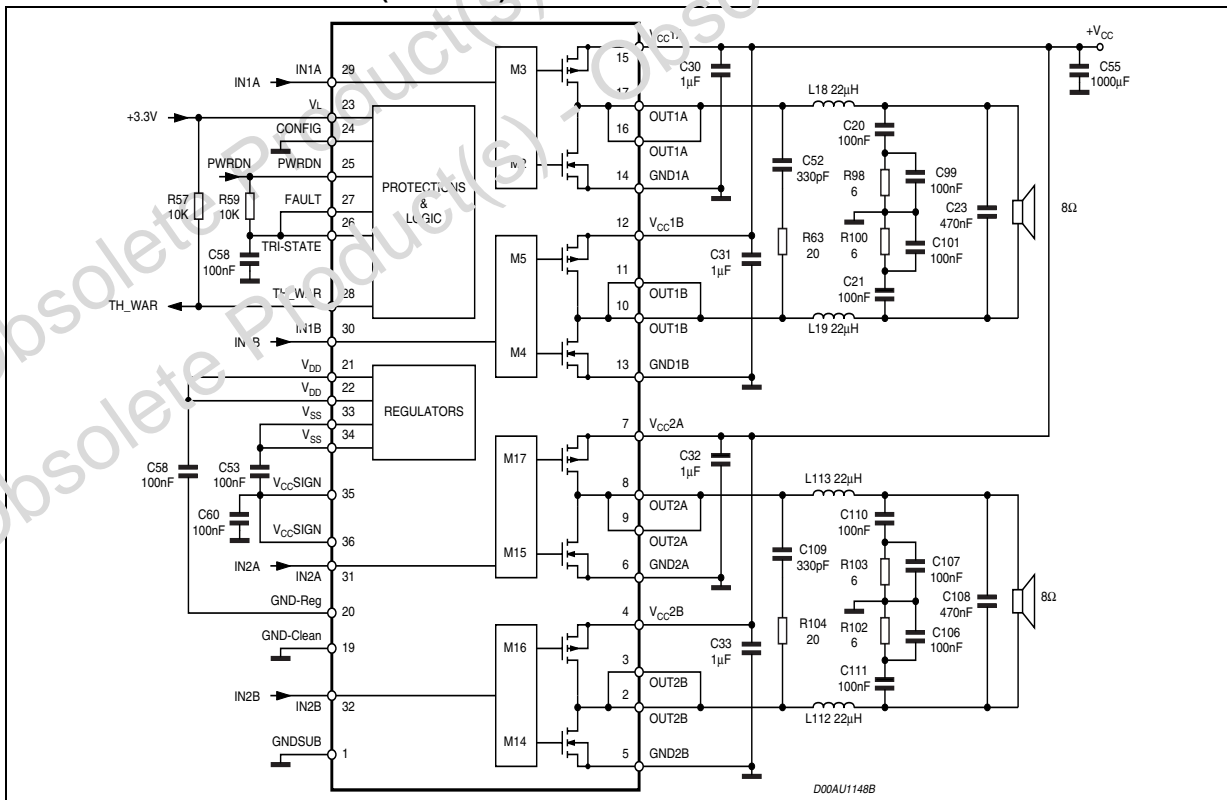

Rev. 7

STA500

PIN FUNCTION

N°	Pin	Description
1	GND-SUB	Substrate ground
35 ; 36	Vcc Sign	Signal Positive supply
15	Vcc1A	Positive Supply
12	Vcc1B	Positive Supply
7	Vcc2A	Positive Supply
4	Vcc2B	Positive Supply
14	GND1A	Negative Supply
13	GND1B	Negative Supply
6	GND2A	Negative Supply
5	GND2B	Negative Supply
16 ; 17	OUT1A	Output half bridge 1A
10 ; 11	OUT1B	Output half bridge 1B
8 ; 9	OUT2A	Output half bridge 2A
2 ; 3	OUT2B	Output half bridge 2B
29	IN1A	Input of half bridge 1A
30	IN1B	Input of half bridge 1B
31	IN2A	Input of half bridge 2A
32	IN2B	Input of half bridge 2B
21 ; 22	Vdd	5V Regulator referred to ground
33 ; 34	Vss	5V Regulator referred to +Vcc
25	PWRDN	Stand-by pin (Control input)
26	TRI-STATE	Hi-Z pin (Control input)
27	FAULT	Fault pin advisor (Open Collector Output)
24	CONFIG	Configuration setting pin
28	TH-WAR	Thermal warning advisor (Open Collector Output)
19	GND-clean	Logical ground
23	IBIAS	High logical state setting voltage
18	NC	Not connected
20	GND-Reg	Ground for Vdd regulator

FUNCTIONAL PIN STATUS

PIN NAME	Logical value	IC -STATUS
FAULT	0	Fault detected (Short circuit, or Thermal ..)
FAULT (*)	1	Normal Operation
TRI-STATE	0	All powers in Hi-Z state
TRI-STATE	1	Normal operation
PWRDN	0	Low absorption
PWRDN	1	Normal operation
THWAR	0	Temperature of the IC =130°C
THWAR(*)	1	Normal operation
CONFIG	0	Normal Operation
CONFIG(**)	1	OUT1A=OUT1B ; OUT2A=OUT2B (IF IN1A = IN1B; IN2A = IN2B)

(*) : The pin is open collector. To have the high logic value, it needs to be pulled up by a resistor.

(**): To put CONFIG = 1 means connect Pin 24 (CONFIG) to Pins 21, 22 (Vdd)

PIN CONNECTION

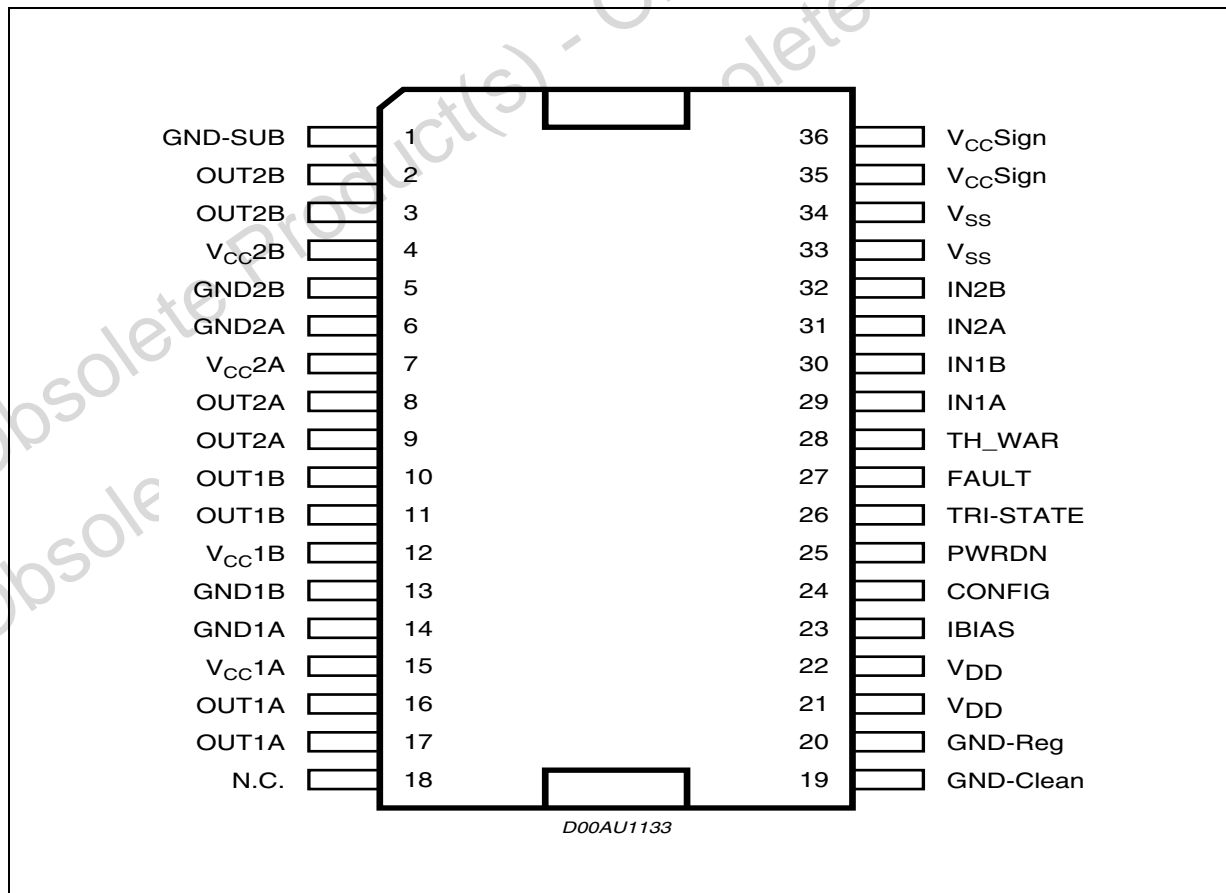

ABSOLUTE MAXIMUM RATINGS

Symbol	Parameter	Value	Unit
V _{CE}	DC Supply Voltage (Pin 4,7,12,15)	40	V
V _{max}	Maximum Voltage on pins (23 to 32)	5.5	V
T _{op}	Operating Temperature Range	0 to 70	°C
T _{stg} , T _j	Storage and Junction Temperature	-40 to 150	°C

THERMAL DATA

Symbol	Parameter	Min.	Typ.	Max.	Unit
T _{j-case}	Thermal Resistance Junction to Case (thermal pad)			2.5	°C/W
T _{jSD}	Thermal shut-down junction temperature		150		°C
T _{warn}	Thermal warning temperature		130		°C
t _{hSD}	Thermal shut-down hysteresis		25		°C

ELECTRICAL CHARACTERISTICS

(I_{bias} = 3.3V; V_{CC} = 28V; T_{amb} = 25°C unless otherwise specified)

Symbol	Parameter	Test conditions	Min.	Typ.	Max.	Unit
R _{dsON}	Power Pchannel/Nchannel MOSFET R _{dsON}	I _d =1A;		200	270	mΩ
I _{dss}	Power Pchannel/Nchannel leakage I _{dss}	V _{CC} =35V			50	μA
g _N	Power Pchannel R _{dsON} Matching (*)	I _d =1A	95			%
g _P	Power Nchannel R _{dsON} Matching (*)	I _d =1A	95			%
Dt _s	Low current Dead Time (static)	see test circuit no.1; see fig. 1		10	20	ns
Dt _d	High current Dead Time (dynamic)	L=22μH; C = 470nF; R _I = 8Ω I _d = 3.5A; see fig. 3			50	ns
t _{d ON}	Turn-on delay time	Resistive load			100	ns
t _{d OFF}	Turn-off delay time	Resistive load			100	ns
t _r	Rise time	Resistive load; as fig. 1			25	ns
t _f	Fall time	Resistive load; as fig. 1			25	ns
V _{CC}	Supply voltage operating voltage		9		V _{OV}	V
V _{IN-H}	High level input voltage		I _{bias} /2 +300mV			V
V _{IN-L}	Low level input voltage				I _{bias} /2 -300mV	V
I _{IN-H}	Hi level Input current	Pin voltage=I _{bias}		1		μA
I _{IN-L}	Low level input current	Pin voltage = 0.3V		1		μA
I _{PWRDN-H}	Hi level PWRDN pin input current	I _{bias} = 3.3V		35		μA
V _L	Low logical state voltage V _L (pin PWRDN, TRISTATE) (note 1)	I _{bias} = 3.3V			0.8	V
V _H	High logical state voltage V _H (pin PWRDN, TRISTATE) (note 1)	I _{bias} = 3.3V	1.7			V

ELECTRICAL CHARACTERISTICS (continued)(I_{bias} = 3.3V; V_{cc} = 28V; T_{amb} = 25°C unless otherwise specified)

Symbol	Parameter	Test conditions	Min.	Typ.	Max.	Unit
I _{VCC-PWRDN}	Supply current from V _{cc} in Power Down	PWRDN = 0			3	mA
I _{FAULT}	Output Current pins FAULT -TH-WARN when FAULT CONDITIONS	V _{pin} = 3.3V		1		mA
I _{VCC-hiz}	Supply current from V _{cc} in Tri-state	Tri-state=0		22		mA

I _{VCC}	Supply current from V _{cc} in operation (both channel switching)	Input pulse width = 50% Duty; Switching Frequency = 384Khz; No LC filters;		80		mA
I _{OUT-SH}	Overcurrent Protection Threshold (short circuit current limit) (note 2)		3.5	6	8	A
V _{OV}	Overvoltage protection threshold		30	35	40	V
V _{UV}	Undervoltage protection threshold			7		V
t _{pw_min}	Output minimum pulse width	No Load	70		150	ns

Notes: 1. The following table explains the VL, VH variation with I_{bias}

I _{bias}	VL _{max}	VH _{min}	Unit
2.7	0.7	1.5	V
3.3	0.8	1.7	V
5	0.85	1.85	V

Note 2: If used in single BTL configuration, the device may be not short circuit protected

LOGIC TRUTH TABLE (see fig. 2)

TRI-STATE	INxA	INxB	Q1	Q2	Q3	Q4	OUTPUT MODE
0	X	X	OFF	OFF	OFF	OFF	Hi-Z
1	0	0	OFF	OFF	ON	ON	DUMP
1	0	1	OFF	ON	ON	OFF	NEGATIVE
1	1	0	ON	OFF	OFF	ON	POSITIVE
1	1	1	ON	ON	OFF	OFF	Not used

Figure 1. Test Circuit.

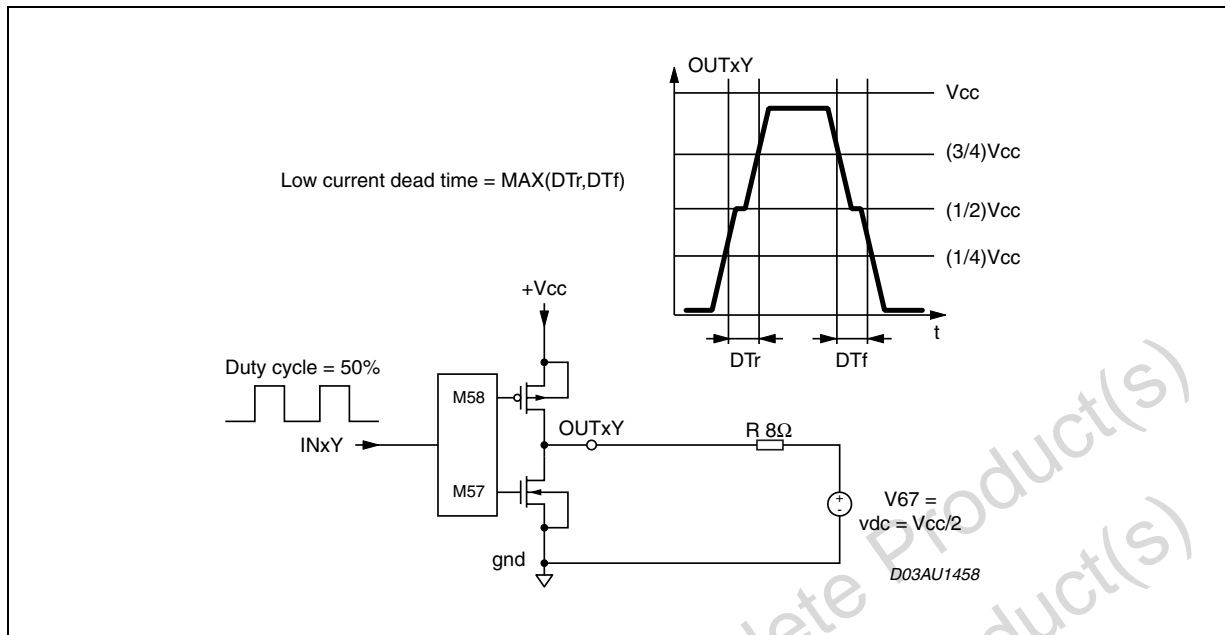

Figure 2.

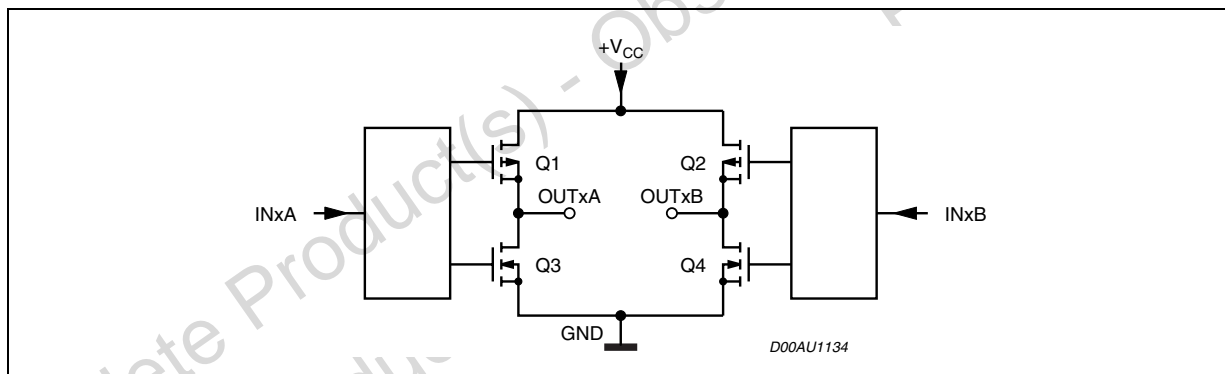

Figure 3.

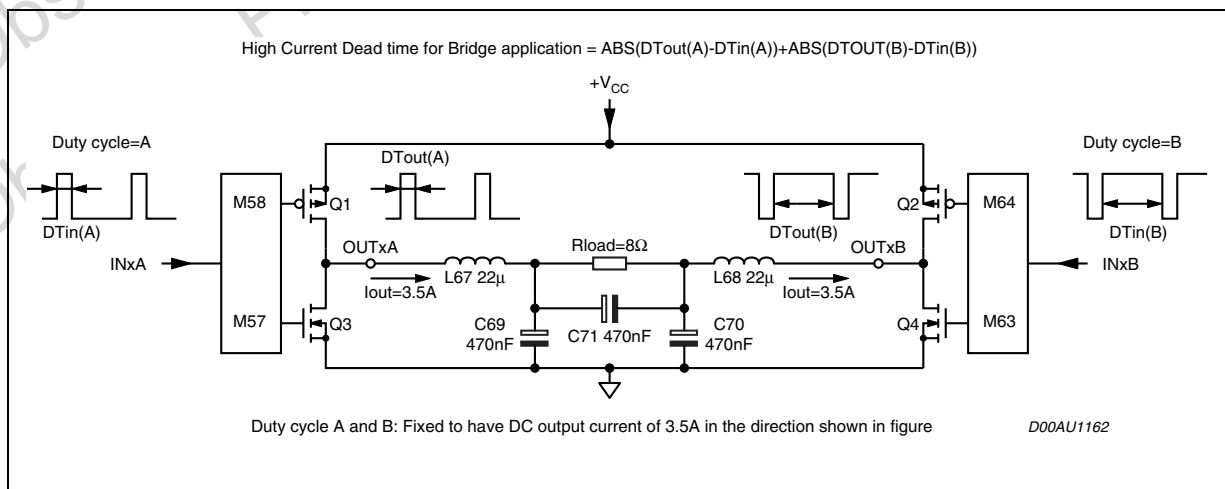
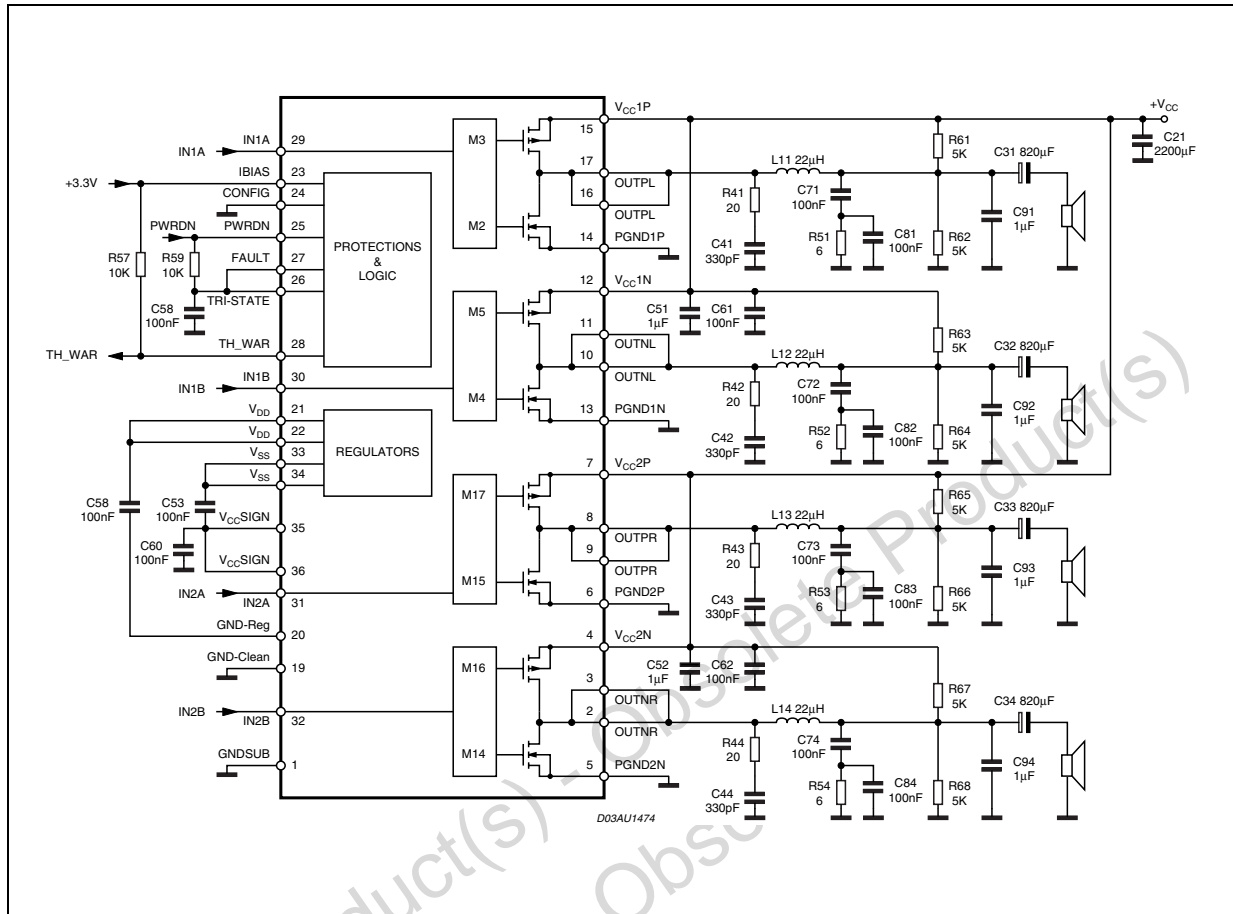

Figure 4. Typical Quad Half Bridge Configuration



Note:

The diagram shown below, have been obtained using the demonstration board described in the application Note AN1456 (STA304 + STA500 Digital Audioprocessor evolution board evaluating manual - Jan 2002), refer to the schematic shown in fig. 1).

For the Quad Half Bridge Configuration (fig. 4), refers to the application note AN1661 (STA308 Half Bridge Board - March 2003)

Figure 5. Distortion vs Output Power (STA304A+STA500)

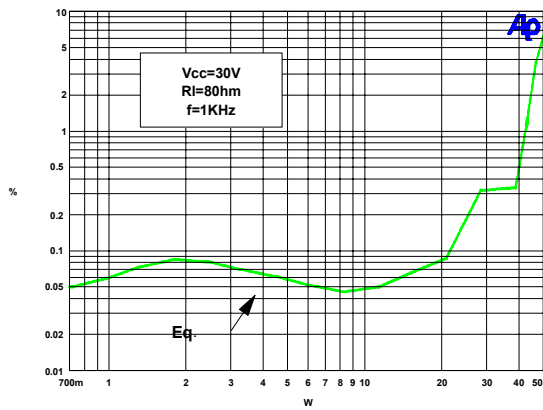

Figure 7. Output Power vs Supply Voltage (STA304A+STA500)

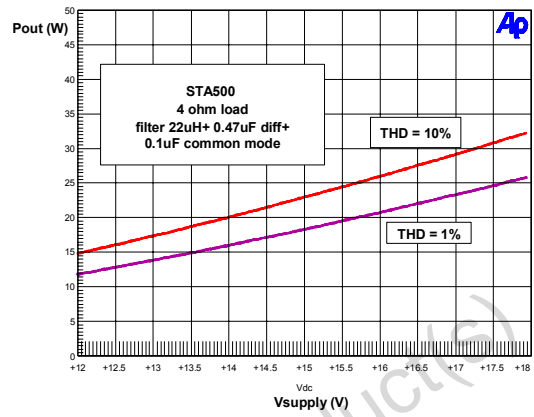

Figure 6. Total Power Dissipation & Efficiency vs Output Power

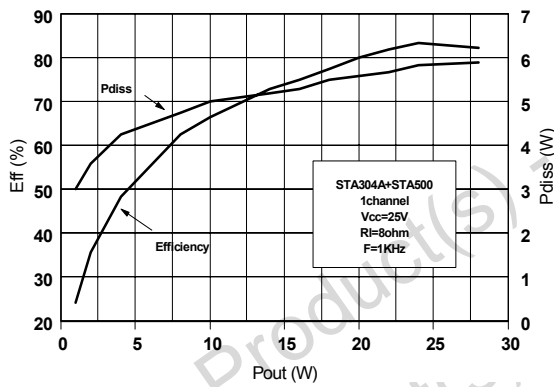

Figure 8. Output Power vs Supply Voltage (STA304A+STA500)

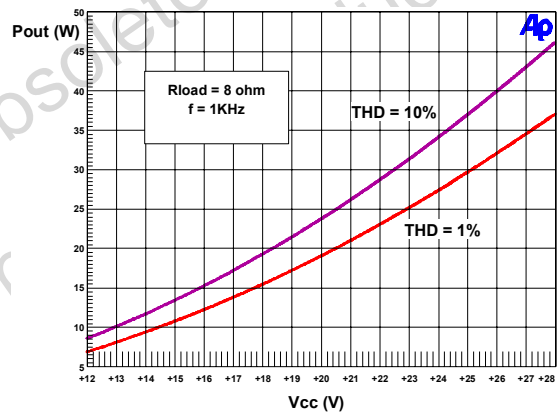

Table 1. Revision History

Date	Revision	Description of Changes
July 2003	6	First Issue
January 2006	7	Modified in the Electrical Characteristics table (page 4) the values of V_{IN-H} , V_{IN-L} , V_L & V_H parameters. Modified the notes 1(page 5).

Obsolete Product(s) - Obsolete Product(s)
Obsolete Product(s) - Obsolete Product(s)

Obsolete Product(s) - Obsolete Product(s)
Obsolete Product(s) - Obsolete Product(s)

Information furnished is believed to be accurate and reliable. However, STMicroelectronics assumes no responsibility for the consequences of use of such information nor for any infringement of patents or other rights of third parties which may result from its use. No license is granted by implication or otherwise under any patent or patent rights of STMicroelectronics. Specifications mentioned in this publication are subject to change without notice. This publication supersedes and replaces all information previously supplied. STMicroelectronics products are not authorized for use as critical components in life support devices or systems without express written approval of STMicroelectronics.

The ST logo is a registered trademark of STMicroelectronics.
All other names are the property of their respective owners

© 2006 STMicroelectronics - All rights reserved

STMicroelectronics group of companies

Australia - Belgium - Brazil - Canada - China - Czech Republic - Finland - France - Germany - Hong Kong - India - Israel - Italy - Japan -
Malaysia - Malta - Morocco - Singapore - Spain - Sweden - Switzerland - United Kingdom - United States of America

www.st.com