



Chipsmall Limited consists of a professional team with an average of over 10 year of expertise in the distribution of electronic components. Based in Hongkong, we have already established firm and mutual-benefit business relationships with customers from,Europe,America and south Asia,supplying obsolete and hard-to-find components to meet their specific needs.

With the principle of “Quality Parts,Customers Priority,Honest Operation,and Considerate Service”,our business mainly focus on the distribution of electronic components. Line cards we deal with include Microchip,ALPS,ROHM,Xilinx,Pulse,ON,Everlight and Freescale. Main products comprise IC,Modules,Potentiometer,IC Socket,Relay,Connector.Our parts cover such applications as commercial,industrial, and automotives areas.

We are looking forward to setting up business relationship with you and hope to provide you with the best service and solution. Let us make a better world for our industry!



Contact us

Tel: +86-755-8981 8866 Fax: +86-755-8427 6832

Email & Skype: info@chipsmall.com Web: www.chipsmall.com

Address: A1208, Overseas Decoration Building, #122 Zhenhua RD., Futian, Shenzhen, China



40 V, 3 A, quad power half bridge

Datasheet - production data

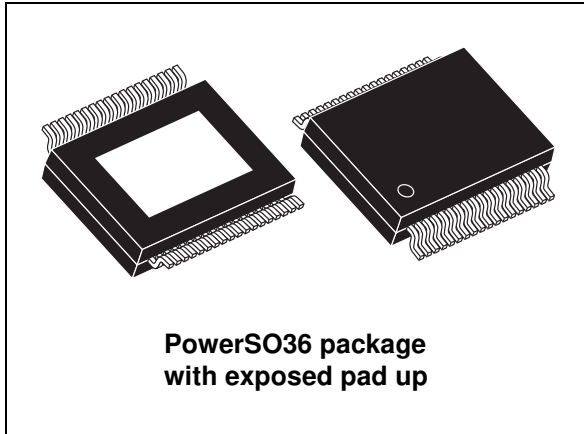

Features

- Multipower BCD technology
- Low input/output pulse width distortion
- 200 mΩ R_{dsON} complementary DMOS output stage
- CMOS-compatible logic inputs
- Thermal protection
- Thermal warning output
- Undervoltage protection
- Short-circuit protection

Description

The STA515W is a monolithic quad half-bridge stage in Multipower BCD Technology. The device can be used as a dual bridge or reconfigured, by connecting pin CONFIG to pins VDD, as a single bridge with double-current capability.

The device is designed, particularly, to be the output stage of a stereo all-digital high-efficiency amplifier. It is capable of delivering 10 W x 4 channels into 4 Ω loads with 10% THD at $V_{CC} = 18$ V in single-ended configuration.

It can also deliver 20 W + 20 W into 8 Ω loads with 10% THD at $V_{CC} = 18$ V in BTL configuration or, in single parallel BTL configuration, 40 W into a 8 Ω load with 10% THD at $V_{CC} = 26$ V.

The input pins have a threshold proportional to the voltage on pin V_L .

The STA515W comes in a 36-pin PowerSSO package with exposed pad down (EPD).

Table 1. Device summary

Order code	Ambient temp. range	Package	Packaging
STA515W13TR	0 to 70 °C	PowerSSO36 EPD	Tape and reel

1 Introduction

Figure 1. STA515W circuit for quad single-ended amplifiers

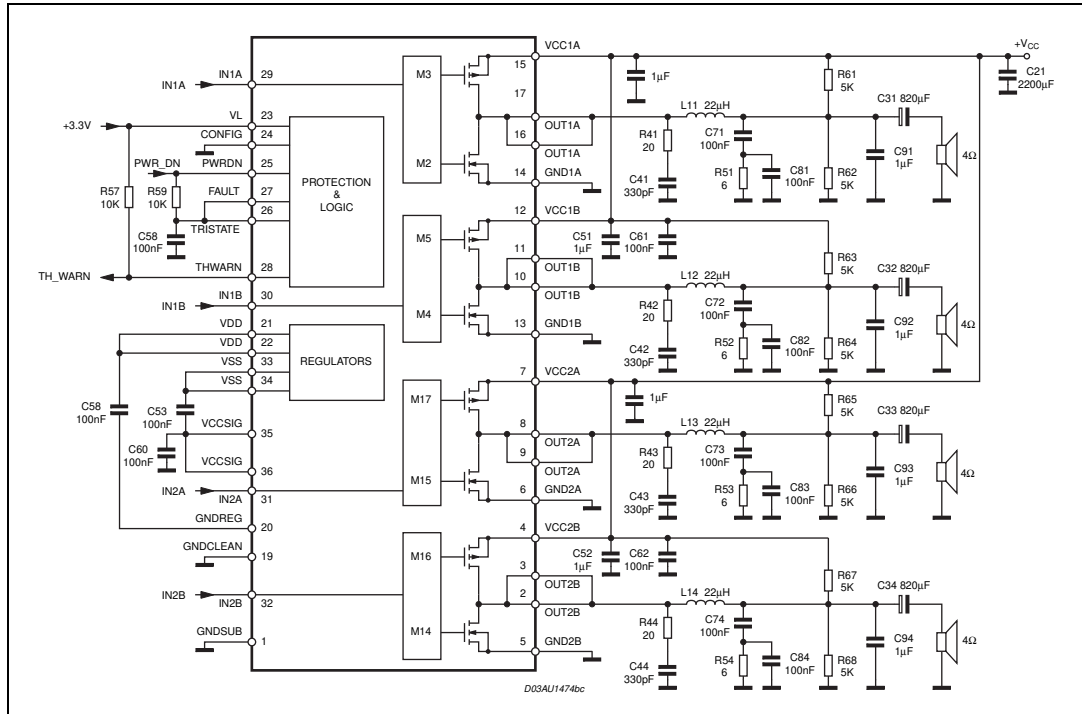

2 Pin description

Figure 2. Pin out

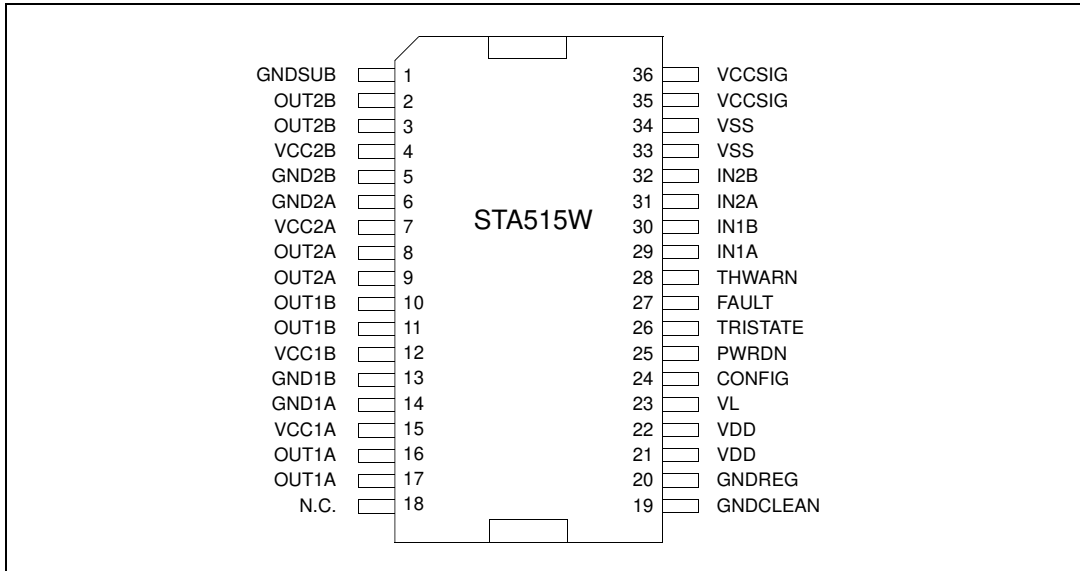

Table 2. Pin list

Pin	Name	Type	Description
1	GNDSUB	PWR	Substrate ground
2, 3	OUT2B	O	Output half bridge 2B
4	VCC2B	PWR	Positive supply
5	GND2B	PWR	Negative supply
6	GND2A	PWR	Negative supply
7	VCC2A	PWR	Positive supply
8, 9	OUT2A	O	Output half bridge 2A
10, 11	OUT1B	O	Output half bridge 1B
12	VCC1B	PWR	Positive supply
13	GND1B	PWR	Negative supply
14	GND1A	PWR	Negative supply
15	VCC1A	PWR	Positive supply
16, 17	OUT1A	O	Output half bridge 1A
18	N.C.	-	No internal connection
19	GNDCLEAN	PWR	Logical ground
20	GNDREG	PWR	Ground for regulator V_{DD}
21, 22	VDD	PWR	5-V regulator referred to ground
23	VL	PWR	High logical state setting voltage, V_L

Table 2. Pin list (continued)

Pin	Name	Type	Description
24	CONFIG	I	Configuration pin: 0: normal operation 1: bridges in parallel, see Parallel-output and high-current operation on page 10
25	PWRDN	I	Stand-by pin: 0: low-power mode 1: normal operation
26	TRISTATE	I	Hi-Z pin: 0: all power amplifier outputs in high-impedance state 1: normal operation
27	FAULT	O	Fault pin advisor (open-drain device, needs pull-up resistor): 0: fault detected (short circuit or thermal, for example) 1: normal operation
28	THWARN	O	Thermal-warning advisor (open-drain device, needs pull-up resistor): 0: temperature of the IC >130 °C 1: normal operation
29	IN1A	I	Input of half bridge 1A
30	IN1B	I	Input of half bridge 1B
31	IN2A	I	Input of half bridge 2A
32	IN2B	I	Input of half bridge 2B
33, 34	VSS	PWR	5-V regulator referred to +V _{CC}
35, 36	VCCSIG	PWR	Signal positive supply

3 Electrical characteristics

Table 3. Absolute maximum ratings

Symbol	Parameter	Value	Unit
V_{CC}	DC supply voltage (Pins 4, 7, 12, 15)	40	V
V_{max}	Maximum voltage on pins 23 to 32	5.5	V
T_{op}	Operating temperature range	0 to 70	°C
P_{tot}	Power dissipation ($T_{case} = 70\text{ °C}$)	21	W
T_{stg}, T_j	Storage and junction temperature	-40 to 150	°C

Table 4. Recommended operating conditions

Symbol	Parameter	Min	Typ	Max	Unit
V_{CC}	DC supply voltage (Pins 4, 7, 12, 15)	10	-	36	V
V_L	Input logic reference	2.7	3.3	5.0	V
T_{amb}	Ambient temperature	0	-	70	°C

Table 5. Thermal data

Symbol	Parameter	Min	Typ	Max	Unit
T_{j-case}	Thermal resistance junction to case (thermal pad)	-	-	1.5	°C/W
T_{jSD}	Thermal shut-down junction temperature	-	150	-	°C
T_{warn}	Thermal warning temperature	-	130	-	°C
t_{hSD}	Thermal shut-down hysteresis	-	25	-	°C

Unless otherwise stated, the test conditions for [Table 6](#) below are $V_L = 3.3\text{ V}$, $V_{CC} = 30\text{ V}$, $R_L = 8\ \Omega$, $f_{SW} = 384\text{ kHz}$ and $T_{amb} = 25\text{ °C}$

Table 6. Electrical characteristics

Symbol	Parameter	Test conditions	Min	Typ	Max	Unit
R_{dsON}	Power P-channel/N-channel MOSFET R_{dsON}	$I_{dd} = 1\text{ A}$	-	200	270	m Ω
I_{dss}	Power P-channel/N-channel leakage I_{dss}	$V_{CC} = 35\text{ V}$	-	-	50	μA
gN	Power P-channel R_{dsON} matching	$I_{dd} = 1\text{ A}$	95	-	-	%
gP	Power N-channel R_{dsON} matching	$I_{dd} = 1\text{ A}$	95	-	-	%
Dt_s	Low current dead time (static)	see Figure 3	-	10	20	ns

Table 6. Electrical characteristics (continued)

Symbol	Parameter	Test conditions	Min	Typ	Max	Unit
Dt_d	High current dead time (dynamic)	$L = 22 \mu\text{H}$, $C = 470 \text{ nF}$ $R_L = 8 \Omega$, $I_{\text{dd}} = 3.0 \text{ A}$ see Figure 4	-	-	50	ns
t _{d ON}	Turn-on delay time	Resistive load	-	-	100	ns
t _{d OFF}	Turn-off delay time	Resistive load	-	-	100	ns
t _r	Rise time	Resistive load see Figure 3	-	-	25	ns
t _f	Fall time	Resistive load see Figure 3	-	-	25	ns
V _{CC}	Supply operating voltage	-	10	-	36	V
V _{IN-Low}	Half-bridge input, low level voltage	-	-	-	$V_L / 2 - 300 \text{ mV}$	V
V _{IN-High}	Half-bridge input, high level voltage	-	$V_L / 2 + 300 \text{ mV}$	-	-	V
I _{IN-H}	High level input current	$V_{\text{IN}} = V_L$	-	1	-	μA
I _{IN-L}	Low level input current	$V_{\text{IN}} = 0.3 \text{ V}$	-	1	-	μA
I _{PWRDN-H}	High level PWRDN pin input current	$V_L = 3.3 \text{ V}$	-	35	-	μA
V _{Low}	Low logical state voltage (pins PWRDN, TRISTATE) (see Table 7)	$V_L = 3.3 \text{ V}$	-	-	0.8	V
V _{High}	High logical state voltage (pins PWRDN, TRISTATE) (see Table 7)	$V_L = 3.3 \text{ V}$	1.7	-	-	V
I _{VCC-PWRDN}	Supply current from V _{CC} in power down	$V_{\text{PWRDN}} = 0 \text{ V}$	-	-	3	mA
I _{FAULT}	Output current on pins FAULT, THWARN with fault condition	$V_{\text{pin}} = 3.3 \text{ V}$	-	1	-	mA
I _{VCC-HIZ}	Supply current from V _{CC} in 3-state	$V_{\text{TRISTATE}} = 0 \text{ V}$	-	22	-	mA
I _{VCC}	Supply current from V _{CC} in operation (both channels switching)	Input pulse width = 50% duty, switching frequency = 384 kHz, no LC filters	-	50	-	mA
I _{OCP}	Overcurrent protection threshold I _{sc} (short circuit current limit)	-	3	6	-	A
V _{UVP}	Undervoltage protection threshold	-	-	7	-	V
t _{pw_min}	Output minimum pulse width	No load	70	-	150	ns

Table 7. Threshold switching voltage variation with voltage on pin VL

Voltage on pin VL, V _L	V _{LOW} max	V _{HIGH} min	Unit
2.7	0.7	1.5	V
3.3	0.8	1.7	V
5.0	0.85	1.85	V

Table 8. Logic truth table

Pin TRISTATE	Inputs as per <i>Figure 4</i>		Transistors as per <i>Figure 4</i>				Output mode
	INxA	INxB	Q1	Q2	Q3	Q4	
0	x	x	Off	Off	Off	Off	Hi Z
1	0	0	Off	Off	On	On	Dump
1	0	1	Off	On	On	Off	Negative
1	1	0	On	Off	Off	On	Positive
1	1	1	On	On	Off	Off	Not used

4 Test circuits

Figure 3. Test circuit

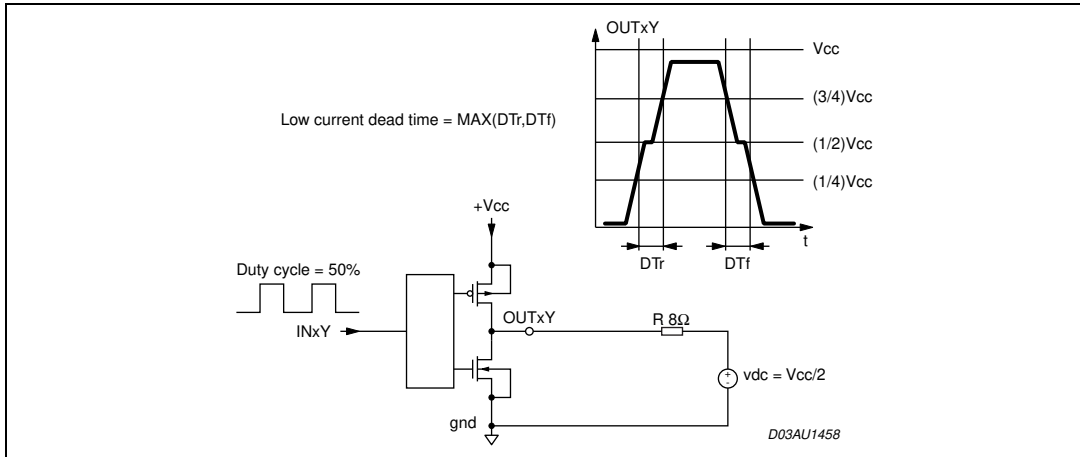
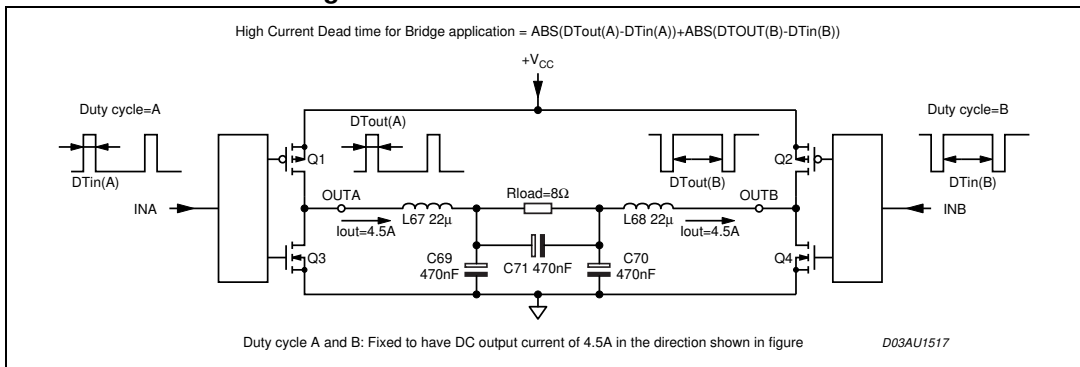

Figure 4. Current dead time test circuit



5 Application information

The STA515W is a dual channel H-bridge that can deliver 20 W per channel into 8 Ω with 10% THD at $V_{CC} = 18\text{ V}$ with high efficiency.

The STA515W converts both DDX and binary-logic-controlled PWM signals into audio power at the load. It includes a logic interface, integrated bridge drivers, high efficiency MOSFET outputs and thermal and short-circuit protection circuitry.

In DDX mode, two logic-level signals per channel are used to control the high-speed MOSFET switches which drive the speaker load in a bridge configuration, according to the damped ternary modulation operation.

In binary mode, both full-bridge and half-bridge modes are supported.

The STA515W includes overcurrent and thermal protection as well as an undervoltage lockout with automatic recovery. A thermal warning status is also provided.

Figure 5. Block diagram for DDX or binary modes

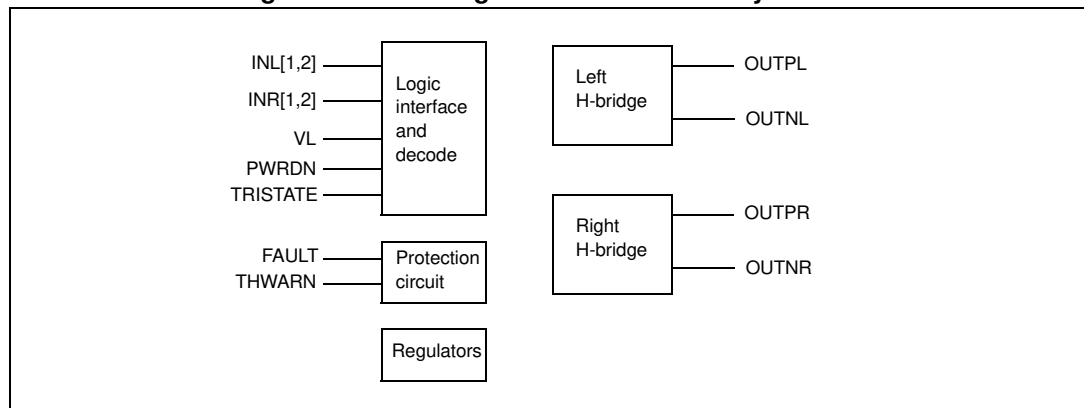
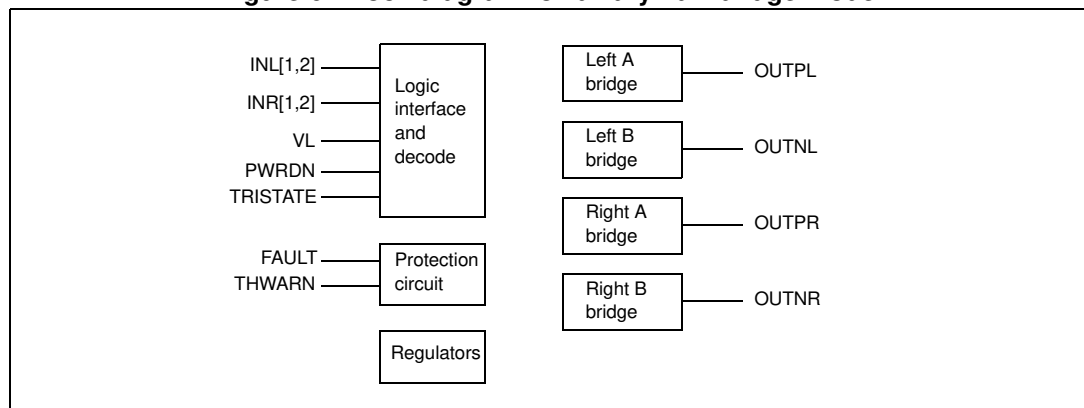

Figure 6. Block diagram for binary half-bridge mode



Logic interface and decode

The STA515W power outputs are controlled using one or two logic-level timing signals. In order to provide a proper logic interface, pin VL must operate at the same voltage as the DDX control logic supply.

Protection circuits

The STA515W includes protection circuitry for overcurrent and thermal overload conditions. A thermal warning pin (THWARN) is activated low (open-drain MOSFET) when the IC temperature exceeds 130 °C, which is in advance of the thermal shutdown protection. When a fault condition is detected an internal fault signal acts to immediately disable the output power MOSFETs, placing both H-bridges in the high-impedance state. At the same time an open-drain MOSFET connected to pin FAULT is switched on.

There are two possible modes subsequent to activating a fault:

- Shutdown mode:
with pins FAULT (with pull-up resistor) and TRISTATE independent, an activated fault disables the device, signalling low at pin FAULT.
The device may subsequently be reset to normal operation by toggling pin TRISTATE from high to low and back to high using an external logic signal.
- Automatic recovery mode:
This is shown in the applications circuit in [Figure 7](#) and [Figure 7 on page 11](#).
Pins FAULT and TRISTATE are shorted together and connected to a time constant circuit comprising R59 and C58.
An activated fault forces a reset on pin TRISTATE causing normal operation to resume following a delay determined by the time constant of the circuit.
If the fault condition is still present, the circuit operation continues, repeating until the fault condition is removed.
An increase in the time constant of the circuit produces a longer recovery interval.

Care must be taken in the overall system design so as not to exceed the protection thresholds under normal operation.

Power outputs

The STA515W power and output pins are duplicated to provide a low-impedance path for the device bridged outputs. All duplicated power, ground and output pins must be connected for proper operation.

Pins PWRDN or TRISTATE should be used to set all MOSFETs to the high-impedance state during power-up and until the logic power supply, VL, has settled.

Parallel-output and high-current operation

When using DDX mode, the STA515W outputs can be connected in parallel to increase the output current capability. In this configuration the device can provide 40 W into 8 Ω.

This mode of operation is enabled with pin CONFIG connected to VDD. The inputs must be combined to give INLA = INLB and INRA = INRB, then the corresponding outputs can be shorted together to give OUTLA = OUTLB and OUTRA = OUTRB.

Output filter

A passive 2nd-order filter is used on the STA515W power outputs to reconstruct an analog audio signal. The system performance can be significantly affected by the output filter design and choice of passive components.

Filter designs for 4-Ω and 8-Ω loads are shown in the applications circuits of [Figure 1 on page 2](#) for the half-bridge mode, and [Figure 7](#) and [Figure 8 on page 11](#) for the full bridge.

Applications circuits

Figure 7 below shows a typical full-bridge circuit for supplying 20 W + 20 W into 8 Ω speakers with 10% THD at V_{CC} = 18 V.

Figure 7. Typical stereo full-bridge configuration for 20 + 20 W

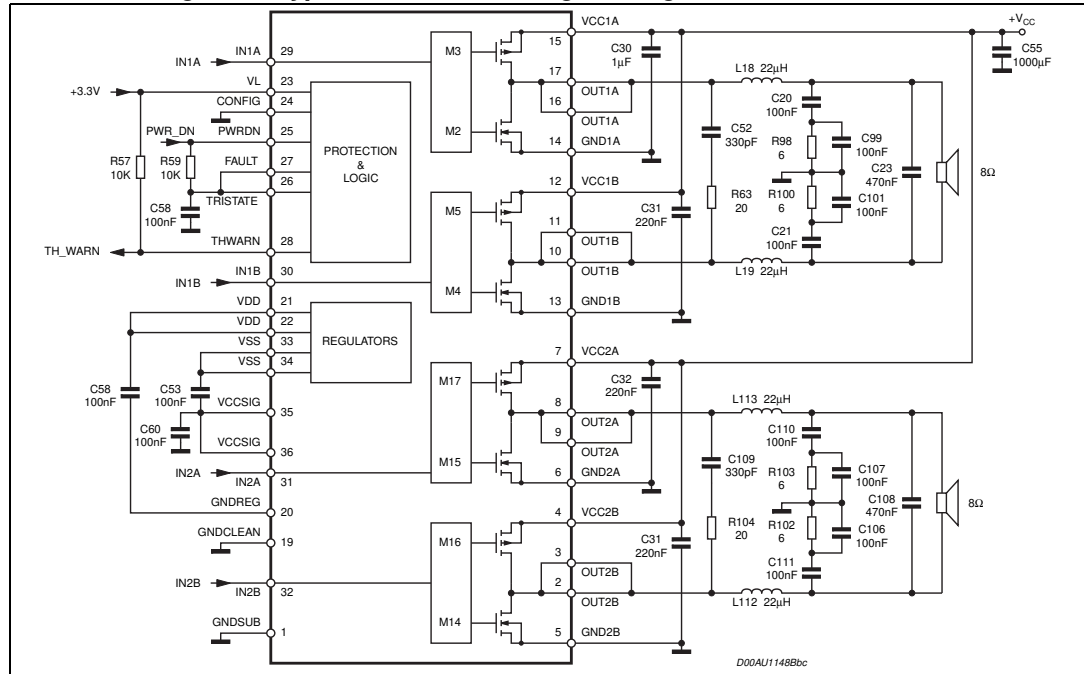
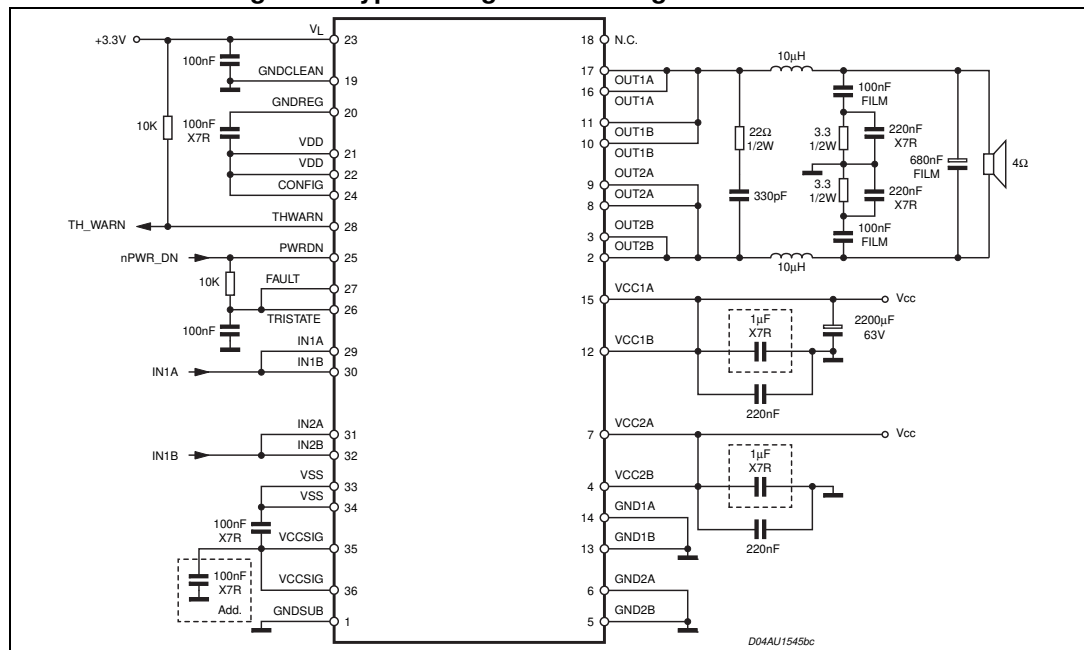

Figure 8 below shows a single-BTL configuration capable of supplying 40 W into a 4 Ω load at 10% THD with V_{CC} = 19 V. This result was obtained with peak power for <1 s using the STA308+STA515W+STA50X demo board. A PWM modulator as driver is required.

Figure 8. Typical single-BTL configuration for 40 W



6 Package mechanical data

In order to meet environmental requirements, ST offers these devices in different grades of ECOPACK[®] packages, depending on their level of environmental compliance. ECOPACK[®] specifications, grade definitions and product status are available at: www.st.com. ECOPACK[®] is an ST trademark.

The STA515W comes in a 36-pin PowerSSO package with exposed pad down (EPD).

[Figure 9](#) below shows the package outline and [Table 9](#) gives the dimensions.

Figure 9. PowerSSO36 EPD outline drawing

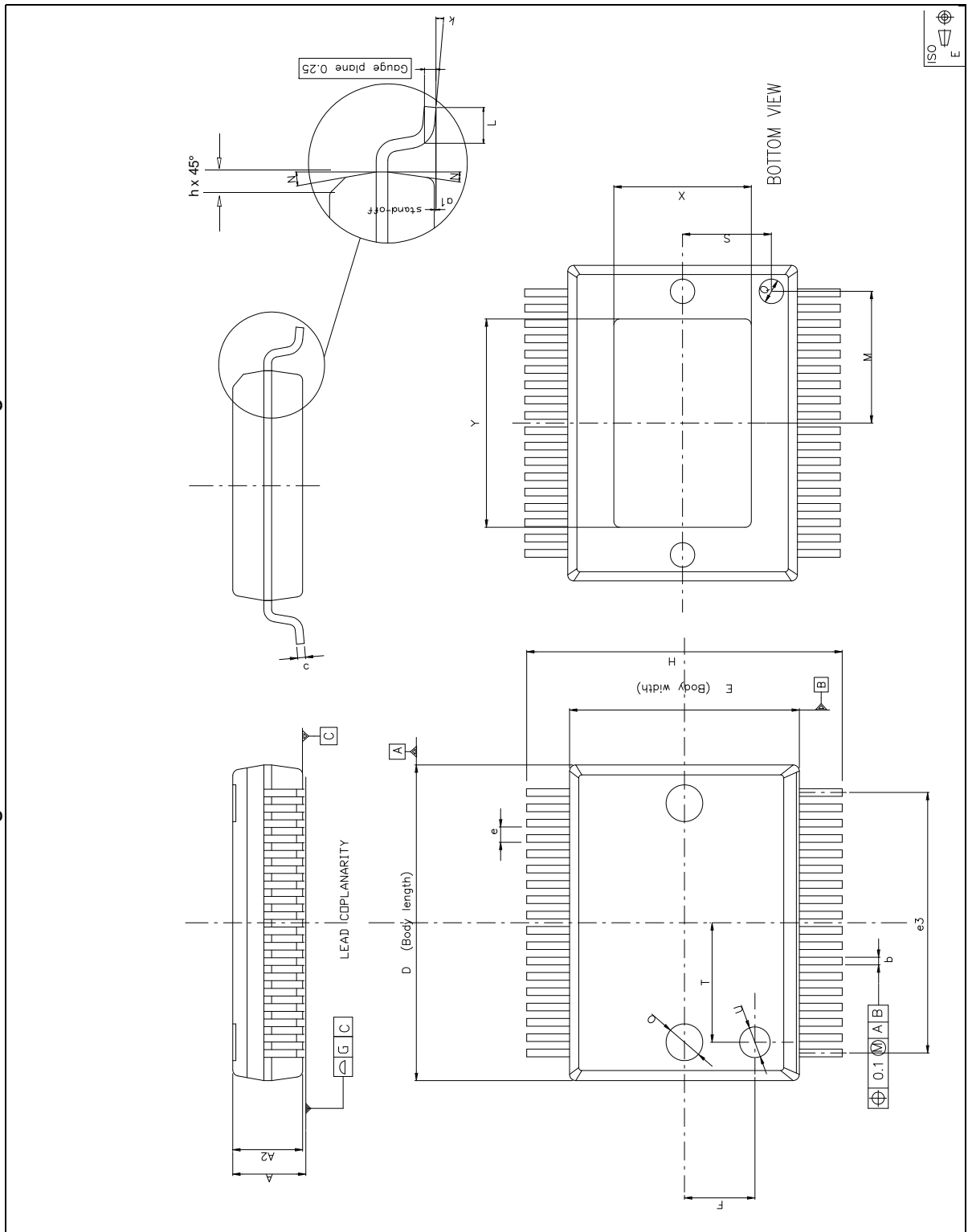

Table 9. PowerSSO36 EPD dimensions

Symbol	Dimensions in mm			Dimensions in inches		
	Min	Typ	Max	Min	Typ	Max
A	2.15	-	2.47	0.085	-	0.097
A2	2.15	-	2.40	0.085	-	0.094
a1	0.00	-	0.10	0.000	-	0.004
b	0.18	-	0.36	0.007	-	0.014
c	0.23	-	0.32	0.009	-	0.013
D	10.10	-	10.50	0.398	-	0.413
E	7.40	-	7.60	0.291	-	0.299
e	-	0.5	-	-	0.020	-
e3	-	8.5	-	-	0.335	-
F	-	2.3	-	-	0.091	-
G	-	-	0.10	-	-	0.004
H	10.10	-	10.50	0.398	-	0.413
h	-	-	0.40	-	-	0.016
k	0	-	8 degrees	0	-	8 degrees
L	0.60	-	1.00	0.024	-	0.039
M	-	4.30	-	-	0.169	-
N	-	-	10 degrees	-	-	10 degrees
O	-	1.20	-	-	0.047	-
Q	-	0.80	-	-	0.031	-
S	-	2.90	-	-	0.114	-
T	-	3.65	-	-	0.144	-
U	-	1.00	-	-	0.039	-
X	4.10	-	4.70	0.161	-	0.185
Y	6.50	-	7.10	0.256	-	0.280

7 Revision history

Table 10. Document revision history

Date	Revision	Changes
Nov-2004	1	Initial release.
27-Apr-2010	2	Added order code STA515W13TR Modified Figure 1 on page 2 Reconstructed pin list in Table 2 on page 3 with information from former table 3 Functional pin status Updated Vlow and Vhigh spec in Table 6 on page 5 Modified Figure 3 and Figure 4 on page 8 Updated applications circuits in Figure 7 and Figure 8 on page 11
24-Feb-2014	3	Updated order code Table 1 on page 1

Please Read Carefully:

Information in this document is provided solely in connection with ST products. STMicroelectronics NV and its subsidiaries ("ST") reserve the right to make changes, corrections, modifications or improvements, to this document, and the products and services described herein at any time, without notice.

All ST products are sold pursuant to ST's terms and conditions of sale.

Purchasers are solely responsible for the choice, selection and use of the ST products and services described herein, and ST assumes no liability whatsoever relating to the choice, selection or use of the ST products and services described herein.

No license, express or implied, by estoppel or otherwise, to any intellectual property rights is granted under this document. If any part of this document refers to any third party products or services it shall not be deemed a license grant by ST for the use of such third party products or services, or any intellectual property contained therein or considered as a warranty covering the use in any manner whatsoever of such third party products or services or any intellectual property contained therein.

UNLESS OTHERWISE SET FORTH IN ST'S TERMS AND CONDITIONS OF SALE ST DISCLAIMS ANY EXPRESS OR IMPLIED WARRANTY WITH RESPECT TO THE USE AND/OR SALE OF ST PRODUCTS INCLUDING WITHOUT LIMITATION IMPLIED WARRANTIES OF MERCHANTABILITY, FITNESS FOR A PARTICULAR PURPOSE (AND THEIR EQUIVALENTS UNDER THE LAWS OF ANY JURISDICTION), OR INFRINGEMENT OF ANY PATENT, COPYRIGHT OR OTHER INTELLECTUAL PROPERTY RIGHT.

ST PRODUCTS ARE NOT DESIGNED OR AUTHORIZED FOR USE IN: (A) SAFETY CRITICAL APPLICATIONS SUCH AS LIFE SUPPORTING, ACTIVE IMPLANTED DEVICES OR SYSTEMS WITH PRODUCT FUNCTIONAL SAFETY REQUIREMENTS; (B) AERONAUTIC APPLICATIONS; (C) AUTOMOTIVE APPLICATIONS OR ENVIRONMENTS, AND/OR (D) AEROSPACE APPLICATIONS OR ENVIRONMENTS. WHERE ST PRODUCTS ARE NOT DESIGNED FOR SUCH USE, THE PURCHASER SHALL USE PRODUCTS AT PURCHASER'S SOLE RISK, EVEN IF ST HAS BEEN INFORMED IN WRITING OF SUCH USAGE, UNLESS A PRODUCT IS EXPRESSLY DESIGNATED BY ST AS BEING INTENDED FOR "AUTOMOTIVE, AUTOMOTIVE SAFETY OR MEDICAL" INDUSTRY DOMAINS ACCORDING TO ST PRODUCT DESIGN SPECIFICATIONS. PRODUCTS FORMALLY ESCC, QML OR JAN QUALIFIED ARE DEEMED SUITABLE FOR USE IN AEROSPACE BY THE CORRESPONDING GOVERNMENTAL AGENCY.

Resale of ST products with provisions different from the statements and/or technical features set forth in this document shall immediately void any warranty granted by ST for the ST product or service described herein and shall not create or extend in any manner whatsoever, any liability of ST.

ST and the ST logo are trademarks or registered trademarks of ST in various countries.

Information in this document supersedes and replaces all information previously supplied.

The ST logo is a registered trademark of STMicroelectronics. All other names are the property of their respective owners.

© 2014 STMicroelectronics - All rights reserved

STMicroelectronics group of companies

Australia - Belgium - Brazil - Canada - China - Czech Republic - Finland - France - Germany - Hong Kong - India - Israel - Italy - Japan - Malaysia - Malta - Morocco - Philippines - Singapore - Spain - Sweden - Switzerland - United Kingdom - United States of America

www.st.com