



Chipsmall Limited consists of a professional team with an average of over 10 year of expertise in the distribution of electronic components. Based in Hongkong, we have already established firm and mutual-benefit business relationships with customers from,Europe,America and south Asia,supplying obsolete and hard-to-find components to meet their specific needs.

With the principle of “Quality Parts,Customers Priority,Honest Operation,and Considerate Service”,our business mainly focus on the distribution of electronic components. Line cards we deal with include Microchip,ALPS,ROHM,Xilinx,Pulse,ON,Everlight and Freescale. Main products comprise IC,Modules,Potentiometer,IC Socket,Relay,Connector.Our parts cover such applications as commercial,industrial, and automotives areas.

We are looking forward to setting up business relationship with you and hope to provide you with the best service and solution. Let us make a better world for our industry!



## Contact us

Tel: +86-755-8981 8866 Fax: +86-755-8427 6832

Email & Skype: info@chipsmall.com Web: www.chipsmall.com

Address: A1208, Overseas Decoration Building, #122 Zhenhua RD., Futian, Shenzhen, China



## RF power transistor: HF/VHF/UHF RF power N-channel MOSFET

Datasheet – production data

### Features

- Operating frequencies up to 40.68 MHz
- Excellent thermal stability
- $P_{OUT} = 350\text{ W}$  with 17 dB gain @ 40.68 MHz/150 V
- Designed for class E operation
- $V_{(BR)DSS} > 700\text{ V}$
- STAC air cavity packaging technology - STAC<sup>®</sup> package
- In compliance with the 2002/95/EC1 European directive

### Description

The STAC150V2-350E is a high voltage N-channel MOS field-effect RF power transistor especially designed for 150V Industrial RF power class E generators such as PECVD plasma sputtering, flat panel and solar cells manufacturing equipments. STAC150V2-350E benefits from the latest generation of STAC<sup>®</sup> air cavity package which exhibits a 25% lower thermal resistance compared to equivalent ceramic package.

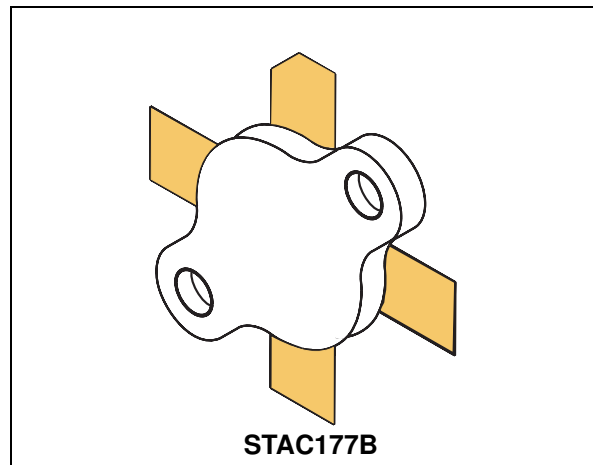

Figure 1. Pin connection

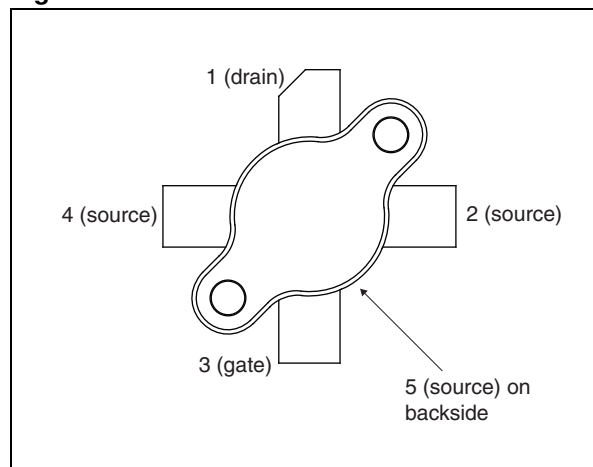

Table 1. Device summary

Order code	Marking	Base qty.	Package	Packaging
STAC150V2-350E	150V2-350 <sup>(1)</sup>	25 pcs	STAC177B	Plastic tray

1. For more details please refer to [Chapter 6: Marking, packing and shipping specifications](#).

# Contents

- 1      Electrical data ..... 3**
  - 1.1    Maximum ratings ..... 3
  - 1.2    Thermal data ..... 3
  
- 2      Electrical characteristics ..... 4**
  - 2.1    Static ..... 4
  - 2.2    Dynamic ..... 4
  
- 3      Impedance data ..... 5**
  
- 4      Typical performance ..... 6**
  
- 5      Package mechanical data ..... 8**
  
- 6      Marking, packing and shipping specifications ..... 10**
  
- 7      Revision history ..... 11**



# 1 Electrical data

## 1.1 Maximum ratings

( $T_{CASE} = 25\text{ °C}$ )

**Table 2. Absolute maximum ratings**

Symbol	Parameter	Value	Unit
$V_{(BR)DSS}$	Drain source voltage	700	V
$V_{GS}$	Gate-source voltage	$\pm 20$	V
$T_J$	Max. operating junction temperature	200	$^{\circ}\text{C}$
$T_{STG}$	Storage temperature	-65 to +150	$^{\circ}\text{C}$

## 1.2 Thermal data

**Table 3. Thermal data**

Symbol	Parameter	Value	Unit
$R_{thJC}$	Junction - case thermal resistance	TBD	$^{\circ}\text{C}/\text{W}$

## 2 Electrical characteristics

$T_{CASE} = +25\text{ }^{\circ}\text{C}$

### 2.1 Static

**Table 4. Static**

Symbol	Test conditions	Min	Typ	Max	Unit
$V_{(BR)DSS}$	$I_{DS} = 250\text{ }\mu\text{A}$	700			V
$I_{DSS}$	$V_{GS} = 0\text{ V}$ $V_{DS} = 150\text{ V}$			1	$\mu\text{A}$
$I_{GSS}$	$V_{GS} = 20\text{ V}$ $V_{DS} = 0\text{ V}$			0.4	$\mu\text{A}$
$V_{TH}$	$I_D = 250\text{ }\mu\text{A}$	3		6.5	V
$V_{DS(ON)}$	$V_{GS} = 10\text{ V}$ $I_D = 7.5\text{ A}$			10	V
$G_{FS}$	$V_{DS} = \text{TBD V}$ $I_D = \text{TBD A}$		TBD		S
$C_{ISS}$	$V_{GS} = 0\text{ V}$ $V_{DS} = 150\text{ V}$ $f = 1\text{ MHz}$		1300		pF
$C_{OSS}$	$V_{GS} = 0\text{ V}$ $V_{DS} = 150\text{ V}$ $f = 1\text{ MHz}$		115		pF
$C_{RSS}$	$V_{GS} = 0\text{ V}$ $V_{DS} = 150\text{ V}$ $f = 1\text{ MHz}$		15		pF

### 2.2 Dynamic

**Table 5. Dynamic (pulse test: 1ms - 10%)**

Symbol	Test conditions	Min	Typ	Max	Unit
$P_{OUT}$	$V_{DD} = 150\text{ V}$ , $P_{IN} = 12\text{ W}$ , $f = 40.68\text{ MHz}$	350	500	-	W
Gain	$V_{DD} = 150\text{ V}$ , $P_{IN} = 12\text{ W}$ , $f = 40.68\text{ MHz}$		16.5	-	dB
Efficiency	$V_{DD} = 150\text{ V}$ , $P_{OUT} = 500\text{ W}$ , $f = 40.68\text{ MHz}$	60	70	-	%
Load mismatch	$V_{DD} = 150\text{ V}$ , $P_{OUT} = 500\text{ W}$ , $f = 40.68\text{ MHz}$		65:1	-	VSWR

### 3 Impedance data

Figure 2. Impedance data

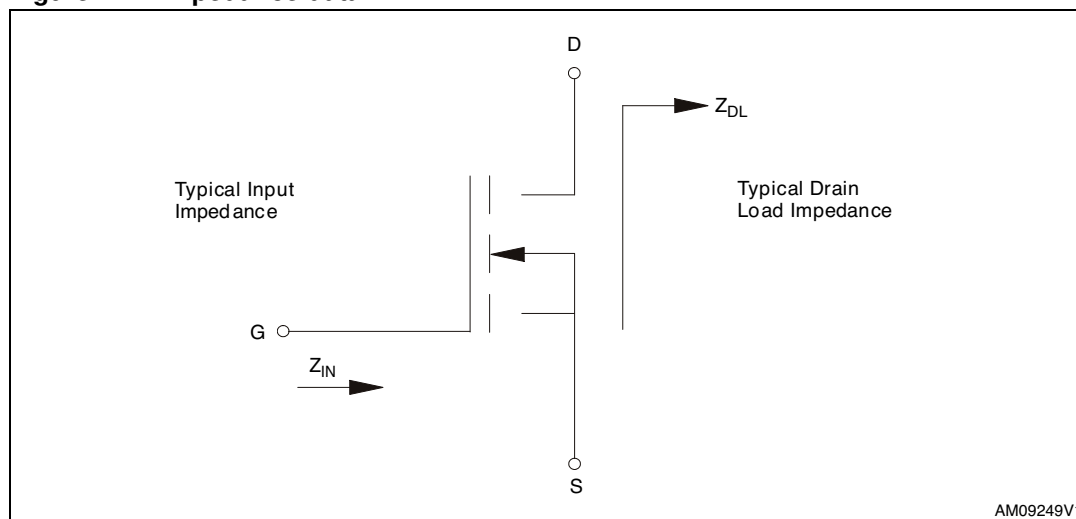
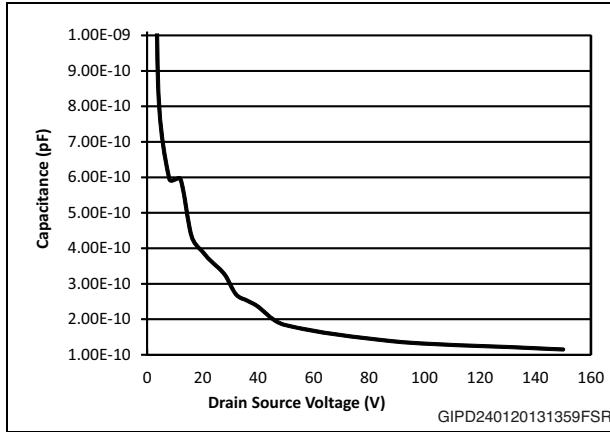

Table 6. Impedance values

Frequency (MHz)	$Z_{in}$	$Z_{dl}$
13.56	TBD	TBD
27.12	TBD	TBD
40.68	$0.6 - j1.5$	$11 + j13$

## 4 Typical performance

**Figure 3.  $C_{OSS}$  capacitance vs. drain-source voltage**



**Figure 4.  $C_{RSS}$  capacitance vs. drain-source voltage**

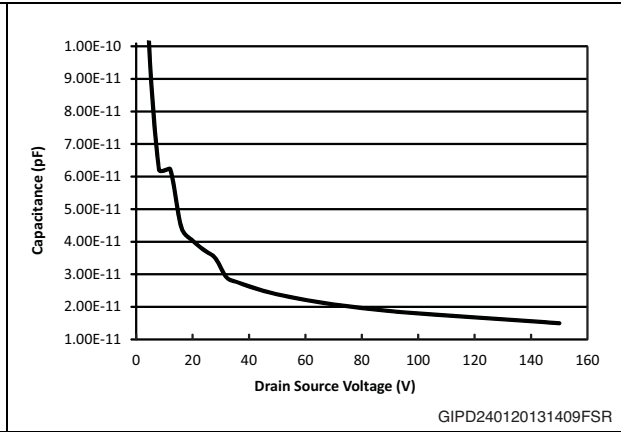

**Figure 5.  $C_{ISS}$  capacitance vs. drain-source voltage**

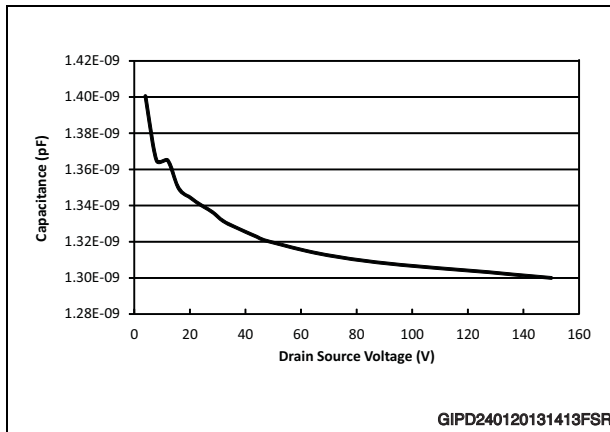
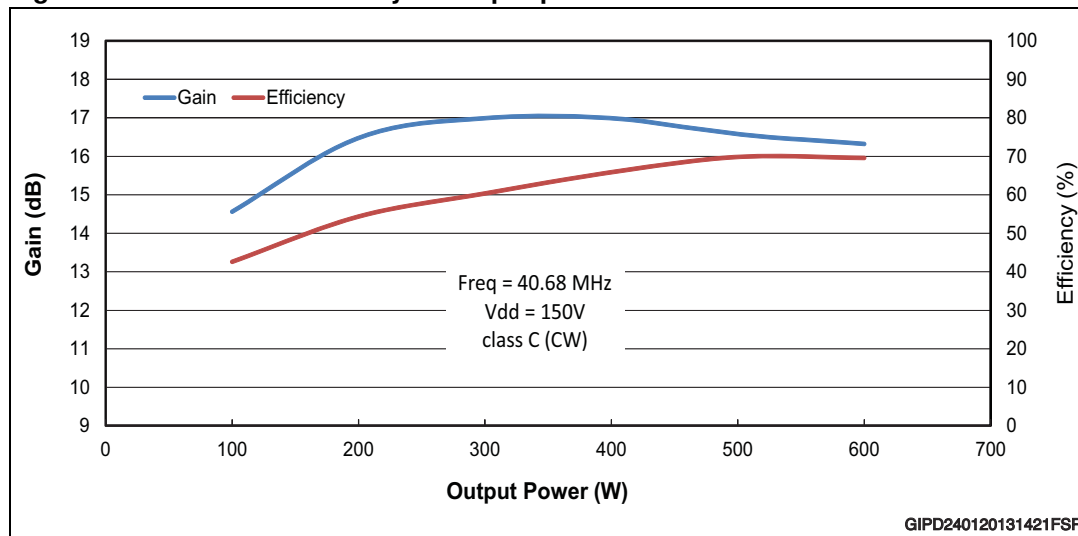

Figure 6. Gain and efficiency vs output power





## 5 Package mechanical data

In order to meet environmental requirements, ST offers these devices in different grades of ECOPACK® packages, depending on their level of environmental compliance. ECOPACK® specifications, grade definitions and product status are available at: [www.st.com](http://www.st.com). ECOPACK is an ST trademark.

**Table 7. STAC177B mechanical data**

Dim	mm			inch		
	Min.	Typ.	Max.	Min.	Typ.	Max.
A	5.72		5.97	0.225		0.235
B	6.73		6.99	0.265		0.275
C	21.84		22.10	0.860		0.870
D	28.70		28.96	1.130		1.140
E		28.02			1.103	
F	0.10		0.15	0.004		0.006
G		0.81			0.032	
H	1.45		1.70	0.057		0.067
I	5.79		6.15	0.228		0.242
J	27.43		28.45	1.080		1.120
K	15.01		15.27	0.591		0.601

Figure 7. STAC177B mechanical drawing

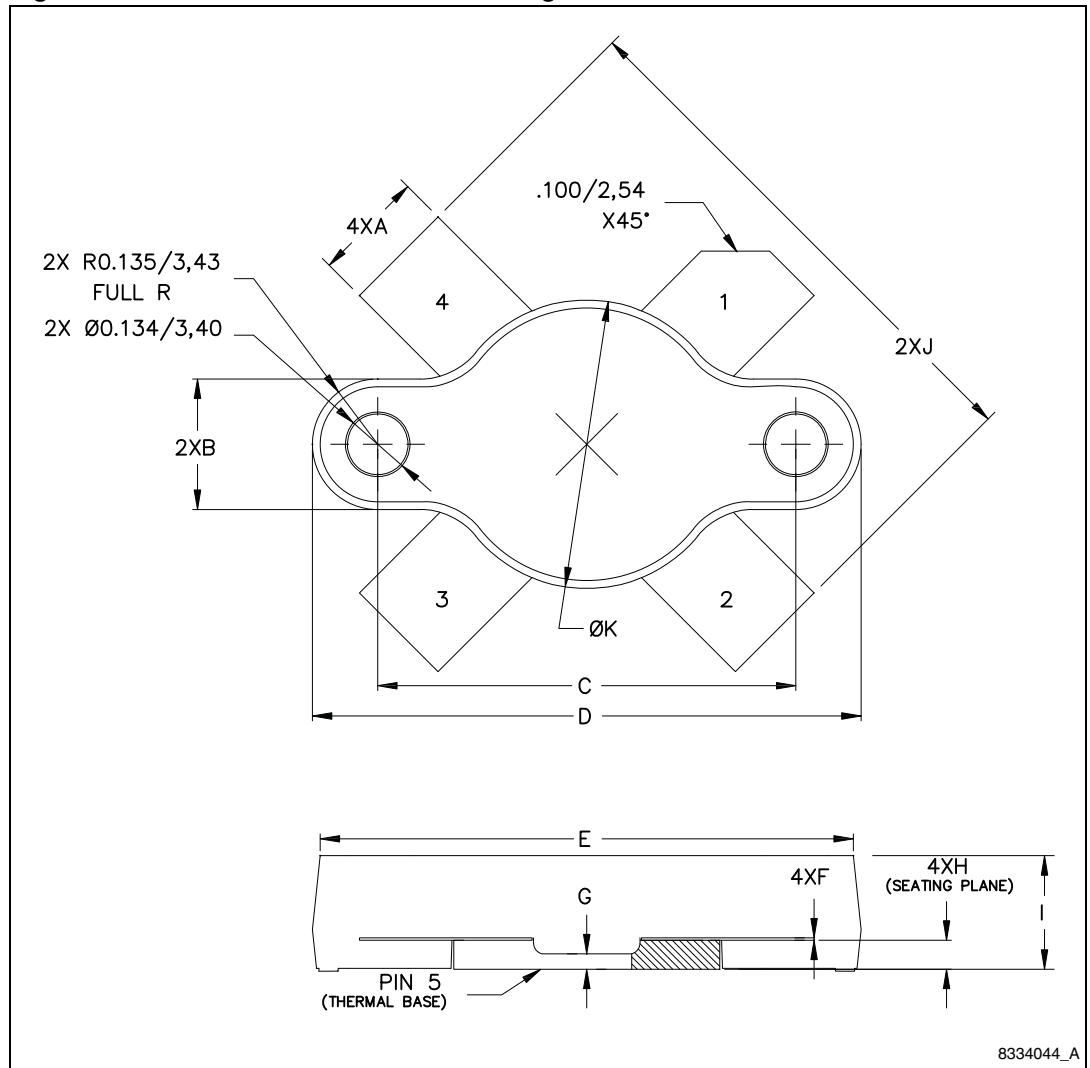

## 6 Marking, packing and shipping specifications

**Table 8. Packing and shipping specifications**

Order code	Packaging	Pcs per tray	Dry pack humidity	Lot code
STAC150V2-350E	Plastic tray	25	< 10 %	Not mixed

**Figure 8. Marking layout**

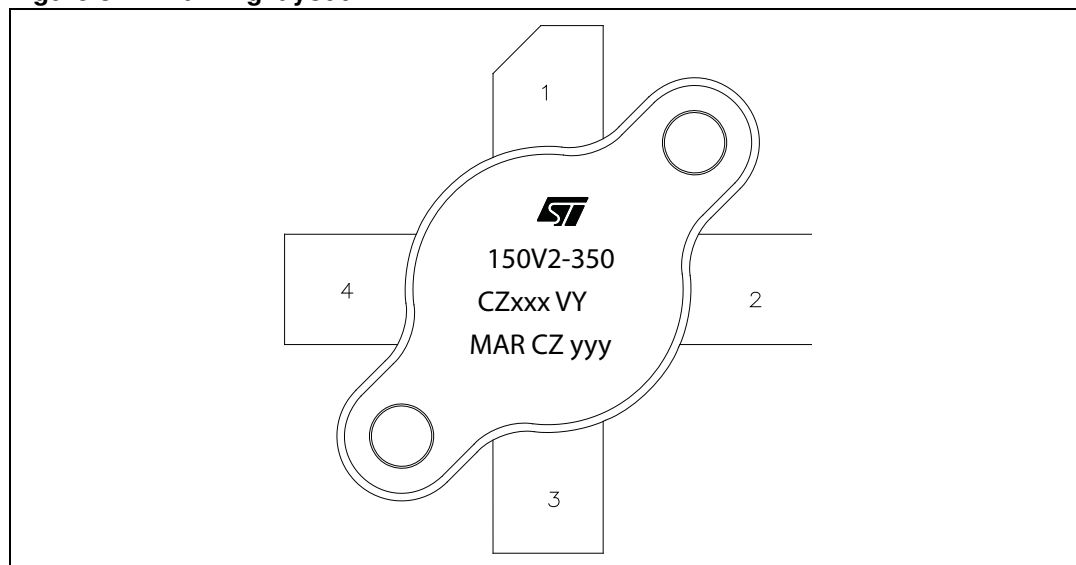

**Table 9. Marking specifications**

Symbol	Description
CZ	Assembly plant
xxx	Last 3 digits of diffusion lot
VY	Diffusion plant
MAR	Country of origin
CZ	Test and finishing plant
y	Assembly year
yy	Assembly week

## 7 Revision history

**Table 10. Document revision history**

Date	Revision	Changes
24-Jan-2013	1	Initial release.

**Please Read Carefully:**

Information in this document is provided solely in connection with ST products. STMicroelectronics NV and its subsidiaries ("ST") reserve the right to make changes, corrections, modifications or improvements, to this document, and the products and services described herein at any time, without notice.

All ST products are sold pursuant to ST's terms and conditions of sale.

Purchasers are solely responsible for the choice, selection and use of the ST products and services described herein, and ST assumes no liability whatsoever relating to the choice, selection or use of the ST products and services described herein.

No license, express or implied, by estoppel or otherwise, to any intellectual property rights is granted under this document. If any part of this document refers to any third party products or services it shall not be deemed a license grant by ST for the use of such third party products or services, or any intellectual property contained therein or considered as a warranty covering the use in any manner whatsoever of such third party products or services or any intellectual property contained therein.

**UNLESS OTHERWISE SET FORTH IN ST'S TERMS AND CONDITIONS OF SALE ST DISCLAIMS ANY EXPRESS OR IMPLIED WARRANTY WITH RESPECT TO THE USE AND/OR SALE OF ST PRODUCTS INCLUDING WITHOUT LIMITATION IMPLIED WARRANTIES OF MERCHANTABILITY, FITNESS FOR A PARTICULAR PURPOSE (AND THEIR EQUIVALENTS UNDER THE LAWS OF ANY JURISDICTION), OR INFRINGEMENT OF ANY PATENT, COPYRIGHT OR OTHER INTELLECTUAL PROPERTY RIGHT.**

**UNLESS EXPRESSLY APPROVED IN WRITING BY TWO AUTHORIZED ST REPRESENTATIVES, ST PRODUCTS ARE NOT RECOMMENDED, AUTHORIZED OR WARRANTED FOR USE IN MILITARY, AIR CRAFT, SPACE, LIFE SAVING, OR LIFE SUSTAINING APPLICATIONS, NOR IN PRODUCTS OR SYSTEMS WHERE FAILURE OR MALFUNCTION MAY RESULT IN PERSONAL INJURY, DEATH, OR SEVERE PROPERTY OR ENVIRONMENTAL DAMAGE. ST PRODUCTS WHICH ARE NOT SPECIFIED AS "AUTOMOTIVE GRADE" MAY ONLY BE USED IN AUTOMOTIVE APPLICATIONS AT USER'S OWN RISK.**

Resale of ST products with provisions different from the statements and/or technical features set forth in this document shall immediately void any warranty granted by ST for the ST product or service described herein and shall not create or extend in any manner whatsoever, any liability of ST.

ST and the ST logo are trademarks or registered trademarks of ST in various countries.

Information in this document supersedes and replaces all information previously supplied.

The ST logo is a registered trademark of STMicroelectronics. All other names are the property of their respective owners.

© 2013 STMicroelectronics - All rights reserved

STMicroelectronics group of companies

Australia - Belgium - Brazil - Canada - China - Czech Republic - Finland - France - Germany - Hong Kong - India - Israel - Italy - Japan - Malaysia - Malta - Morocco - Philippines - Singapore - Spain - Sweden - Switzerland - United Kingdom - United States of America

[www.st.com](http://www.st.com)