



Chipsmall Limited consists of a professional team with an average of over 10 year of expertise in the distribution of electronic components. Based in Hongkong, we have already established firm and mutual-benefit business relationships with customers from,Europe,America and south Asia,supplying obsolete and hard-to-find components to meet their specific needs.

With the principle of "Quality Parts,Customers Priority,Honest Operation,and Considerate Service",our business mainly focus on the distribution of electronic components. Line cards we deal with include Microchip,ALPS,ROHM,Xilinx,Pulse,ON,Everlight and Freescale. Main products comprise IC,Modules,Potentiometer,IC Socket,Relay,Connector.Our parts cover such applications as commercial,industrial, and automotives areas.

We are looking forward to setting up business relationship with you and hope to provide you with the best service and solution. Let us make a better world for our industry!



Contact us

Tel: +86-755-8981 8866 Fax: +86-755-8427 6832

Email & Skype: info@chipsmall.com Web: www.chipsmall.com

Address: A1208, Overseas Decoration Building, #122 Zhenhua RD., Futian, Shenzhen, China



800 mA standalone linear Li-Ion battery charger with thermal regulation

Datasheet - production data

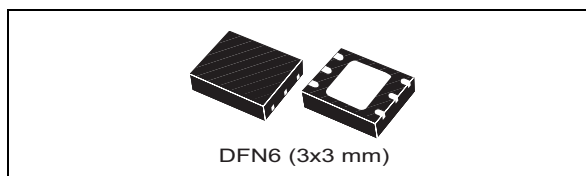

Features

- Programmable charge current up to 800 mA
- No external MOSFET, sense resistors or blocking diode are required
- Complete linear charger for single-cell Li-Ion batteries
- Constant current/constant voltage operation with thermal regulation to maximize charge rate without risk of overheating
- Two charge status output pins
- Charge single-cell Li-Ion batteries directly from USB port
- Preset 4.2 V charge voltage with 1% accuracy
- Charge current monitor for gas gauge
- Automatic recharge
- Undervoltage lockout
- C/10 charge termination
- 25 μ A supply current in shutdown mode
- Low battery voltage detection for pre-charge setting
- Soft-start feature limits inrush current
- DFN6 (3x3 mm) package (to improve power dissipation)

Applications

- Cellular phones
- PDAs
- Bluetooth[®] applications
- Battery-powered devices

Description

The STBC08 is a constant current/constant voltage charger for single-cell Li-Ion batteries. Neither external sense resistor nor blocking diode are required. The STBC08 is designed to work within USB power specifications. An internal block regulates the current when the junction temperature increases, to protect the device when it operates in high power or high ambient temperature conditions. The charge voltage is fixed at 4.2 V, and current limitation can be programmed using a single resistor connected between PROG pin and GND. The charge cycle is automatically terminated when the current, which flows to the battery, is 1/10 of the programmed value. If the external adapter is removed, the STBC08 turns off and a 2 μ A current can flow from the battery to the device. The device can be in shutdown mode, reducing the supply current to 25 μ A. The device also has a charge current monitor, undervoltage lockout, automatic recharge. The charge termination and input voltage presence are indicated by two separated status pins.

Table 1. Device summary

Part number	Package	Packaging
STBC08PMR	DFN6 (3x3 mm)	4500 pieces/reel

Contents

1	Block diagram	5
2	Pin configuration	6
3	Maximum ratings	8
4	Electrical characteristics	9
5	Typical performance characteristics	11
6	Application information	13
6.1	Charge cycle	13
6.2	V _{CC} pin	13
6.3	POWER ON pin	13
6.4	CHRG pin	13
6.5	PROG pin	14
6.6	Programming charge current	14
6.7	BAT pin	15
6.8	Charge termination	15
6.9	Automatic recharge	15
6.10	Soft-start	15
6.11	Thermal regulation	15
6.12	Power dissipation	15
6.13	Stability considerations	16
7	Package mechanical data	17
8	Packaging mechanical data	19
9	Revision history	21

List of tables

Table 1.	Device summary	1
Table 2.	Pin description	6
Table 3.	Absolute maximum ratings	8
Table 4.	Thermal data	8
Table 5.	Electrical characteristics	9
Table 6.	Flag status values for CHRG pin	13
Table 7.	DFN6 (3x3 mm) mechanical data	18
Table 8.	DFN6 (3x3 mm) tape and reel mechanical data	20
Table 9.	Document revision history	21

List of figures

Figure 1.	Block diagram	5
Figure 2.	Pin connection (top view)	6
Figure 3.	Application circuit	7
Figure 4.	I_{BAT} vs. supply voltage	11
Figure 5.	V_{BAT} vs. V_{CC}	11
Figure 6.	I_{BAT} vs. temperature	11
Figure 7.	V_{PROG} vs. temperature	11
Figure 8.	I_{BAT}/I_{PROG} vs. temperature	11
Figure 9.	Recharge battery threshold voltage vs. temperature	11
Figure 10.	I_{BAT}/I_{PROG} vs. V_{CC}	12
Figure 11.	I_{BAT} vs. V_{BAT}	12
Figure 12.	V_{CHRG} vs. temperature (CHRG pin output low voltage)	12
Figure 13.	I_{BAT} vs. V_{PROG}	12
Figure 14.	Power FET on-resistance	12
Figure 15.	DFN6 (3x3 mm) drawings	17
Figure 16.	DFN6 (3x3 mm) recommended footprint	18
Figure 17.	DFN6 (3x3 mm) tape	19
Figure 18.	DFN6 (3x3 mm) reel	20

1 Block diagram

Figure 1. Block diagram

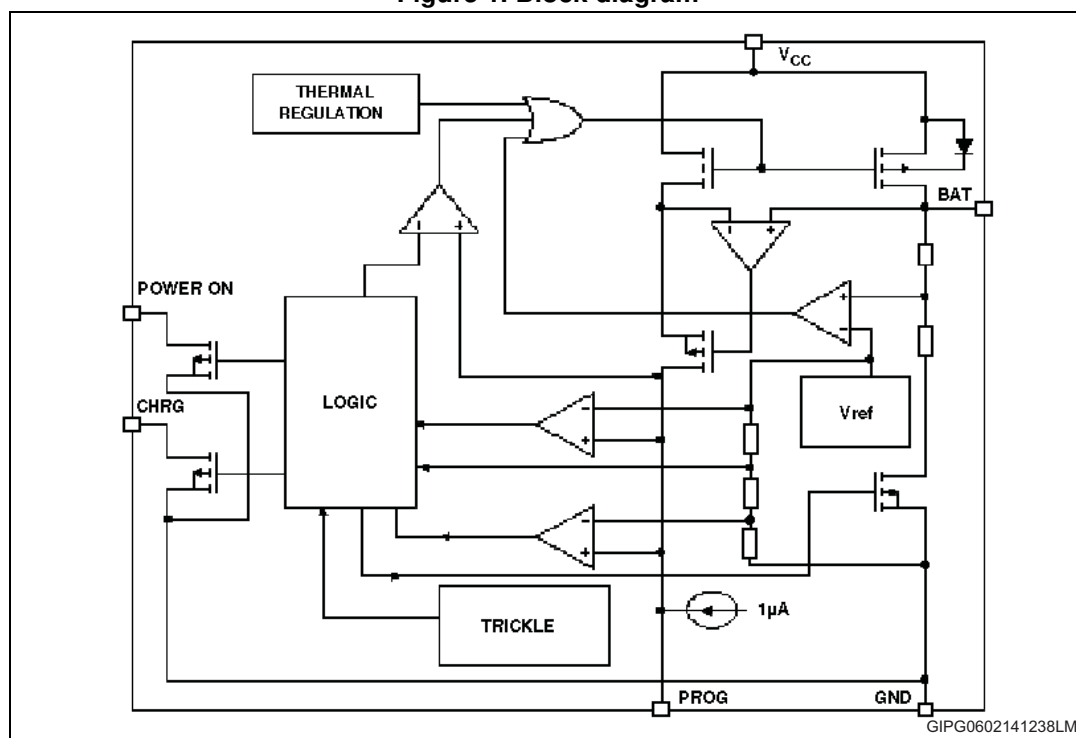

2 Pin configuration

Figure 2. Pin connection (top view)

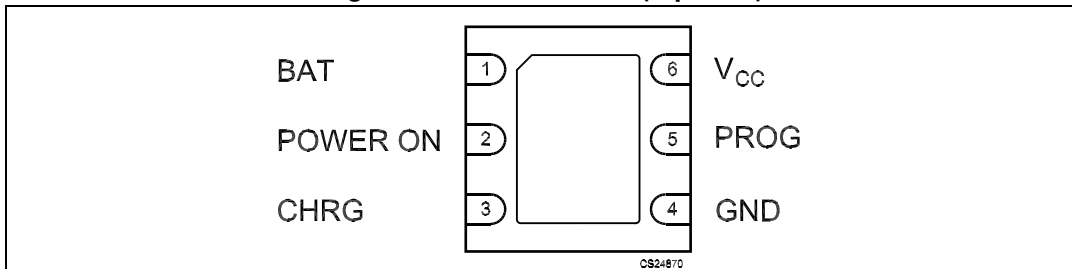
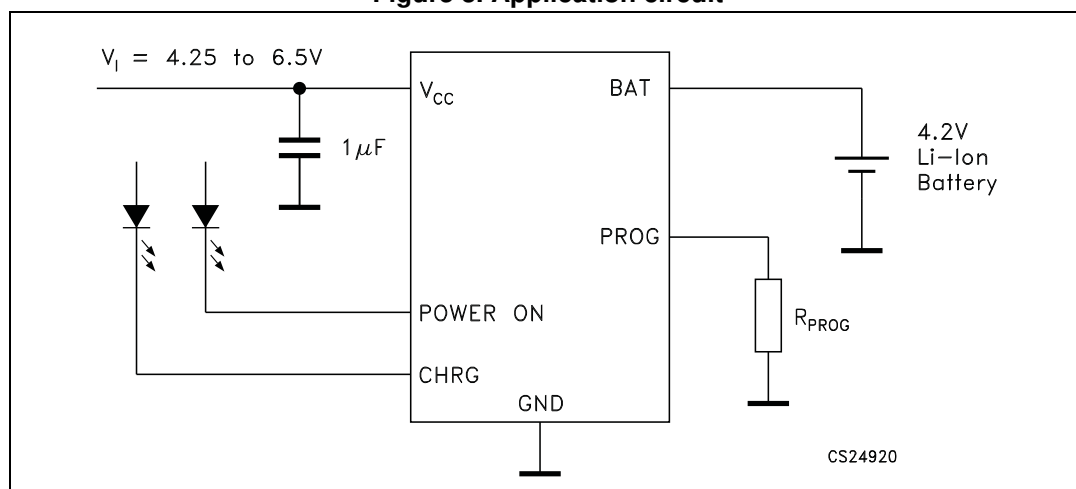

Table 2. Pin description

Pin	Symbol	Notes
1	BAT	This pin provides an accurate output voltage of 4.2 V and the charge current to the battery. Only 2 μ A reverse current can flow to the device when it is in shutdown mode.
2	POWER ON	Open drain. When the STBC08 detects an undervoltage lockout condition or when the external adapter provides an input voltage higher than 7.2 V or less than the battery voltage, POWER ON goes to high impedance state.
3	CHRGR	Open drain. This pin goes to low impedance when the STBC08 is in pre-charge or charge mode.
4	GND	Ground pin.
5	PROG	Charge current program, charge current monitor and shutdown pin. The current limitation is programmed using R_{PROG} tolerance of 1% between PROG pin and GND.
6	V_{CC}	Input supply voltage. The input range goes from 4.25 to 6.5 V. If $V_{CC} < V_{BAT} + 30$ mV the device enters shutdown mode and the sinked I_{BAT} is less than 2 μ A.
7	Exposed pad	Connected to GND or left floating.

Figure 3. Application circuit



3 Maximum ratings

Table 3. Absolute maximum ratings

Symbol	Parameter	Value	Unit
V_{CC}	Input supply voltage	From -0.3 to 10	V
V_{BAT}	Battery pin voltage	From -0.3 to $V_{CC}+0.3$	V
V_{PROG}	PROG pin voltage	From -0.3 to $V_{CC}+0.3$	V
V_{CHRG}	CHRG pin voltage	From -0.3 to 7	V
$V_{POWER-ON}$	POWER ON pin voltage	From -0.3 to 7	V
V_{LV}	TEMP, LED1, LED2, ISET	From -0.3 to $V_{REF}+0.3$	V
I_{BAT}	BAT pin current	800	mA
I_{PROG}	PROG pin current	800	μ A
	BAT short-circuit duration	Continuous	
P_D	Power dissipation	Internally limited	mW
T_J	Maximum junction temperature	125	$^{\circ}$ C
T_{STG}	Storage temperature range	-65 to 125	$^{\circ}$ C
T_{OP}	Operating junction temperature range	-40 to 85	$^{\circ}$ C

Table 4. Thermal data

Symbol	Parameter	Value	Unit
$R_{th(JA)}$	Thermal resistance junction-ambient	105.7	$^{\circ}$ C/W

4 Electrical characteristics

$V_{CC} = 5\text{ V}$, $C_I = 1\ \mu\text{F}$, $T_J = -40\text{ °C}$ to 85 °C unless otherwise specified^(a)

Table 5. Electrical characteristics

Symbol	Parameter	Test conditions	Min.	Typ.	Max.	Unit	
V_{CC}	Supply voltage		4.25		6.5	V	
I_{CC}	Supply current ⁽¹⁾	Charge mode, $R_{PROG} = 10\text{ k}\Omega$		150	500	μA	
		Standby mode (charge ended)		150	300		
		Shutdown mode	R_{PROG} not connected		21	40	μA
			$V_{CC} < V_{BAT}$		17	50	
$V_{CC} < V_{UV}$		17	40				
V_{BAT}	Termination output voltage	$V_{CC} = 4.3\text{ V}$ to 6.5 V	4.158	4.2	4.242	V	
I_{BAT}	BAT pin current	Current mode $R_{PROG} = 10\text{ k}\Omega$	90	100	110	mA	
		Current mode $R_{PROG} = 2\text{ k}\Omega$	465	500	535	mA	
		Standby mode $V_{BAT} = 4.2\text{ V}$	0	-2.5	-6	μA	
		Shutdown mode ($R_{PROG} =$ not connected) $T_J = 25\text{ °C}$		± 1	± 2		
		Sleep mode, $V_{CC} = 0\text{ V}$, $T_J = 25\text{ °C}$		± 1	± 2		
I_{PRE}	Pre-charge current	$V_{BAT} < 2.8\text{ V}$ $R_{PROG} = 2\text{ k}\Omega$, $T_J = 25\text{ °C}$	20	45	70	mA	
V_{PRE}	Pre-charge threshold	$R_{PROG} = 10\text{ k}\Omega$, V_{BAT} falling	2.8	2.9	3.0	V	
		Hysteresis $R_{PROG} = 10\text{ k}\Omega$	70	100	130	mV	
V_{UV}	V_{CC} undervoltage lockout	V_{CC} low to high $R_{PROG} = 10\text{ k}\Omega$	3.65	3.80	3.95	mV	
		Hysteresis $R_{PROG} = 10\text{ k}\Omega$	50	180	300		
V_{MSD}	Manual shutdown threshold	PROG pin rising	1.15	1.21	1.30	V	
		PROG pin falling	0.85	0.95	1.05		
V_{ASD}	$V_{CC} - V_{BAT}$ lockout threshold	V_{CC} low to high $T_J = 25\text{ °C}$ $R_{PROG} = 10\text{ k}\Omega$	50	85	120	mV	
		V_{CC} high to low $T_J = 25\text{ °C}$ $R_{PROG} = 10\text{ k}\Omega$	5	30	50		

a. The STBC08 has been tested using a battery simulator and an output capacitor value of $4.7\ \mu\text{F}$.

Table 5. Electrical characteristics (continued)

Symbol	Parameter	Test conditions	Min.	Typ.	Max.	Unit
I _{TERM}	C/10 termination current threshold (I _{BAT} /I _{BATC10}) ⁽²⁾	R _{PROG} = 10 kΩ		10		
		R _{PROG} = 2 kΩ		10		
V _{PROG}	PROG pin voltage	Current mode R _{PROG} = 10 kΩ	0.93	1.0	1.07	V
V _{CHRG}	CHRG pin pull-down voltage	I _{CHRG} = 5 mA		0.35	0.6	V
I _{POWER_ON}	POWER ON pin leakage current	Pull-up		1		μA
	POWER ON pin pull-down voltage	I _{POWER_ON} = 5 mA		0.35	0.6	V
ΔV _{RECHRG}	Recharge battery threshold voltage	Battery voltage T _J = 25 °C R _{PROG} = 10 kΩ		200		mV
T _{LIM}	Junction temperature in constant temperature mode			120		°C
R _{ON}	Power FET on-resistance (between V _{CC} and BAT)			600		mΩ
t _{SS}	Soft-start time	I _{BAT} = 0 to I _{BAT} = 1000 V/ R _{PROG}		100		μs
T _{RECHARGE}	Recharge comparator filter time ⁽³⁾	V _{BAT} high to low	0.75	2	4.5	ms
t _{TERM}	Termination comparator filter time ⁽³⁾	I _{BAT} falling below I _{CHG} /10	400	1000	2500	μs
I _{PROG}	PROG pin pull-up current			1		μA

1. Supply current includes PROG pin current but it doesn't include any current delivered to the battery through V_{BAT} pin.
2. I_{TERM} is indicated as a fraction of measured full charge current with indicated PROG resistor.
3. Guaranteed by design.

5 Typical performance characteristics

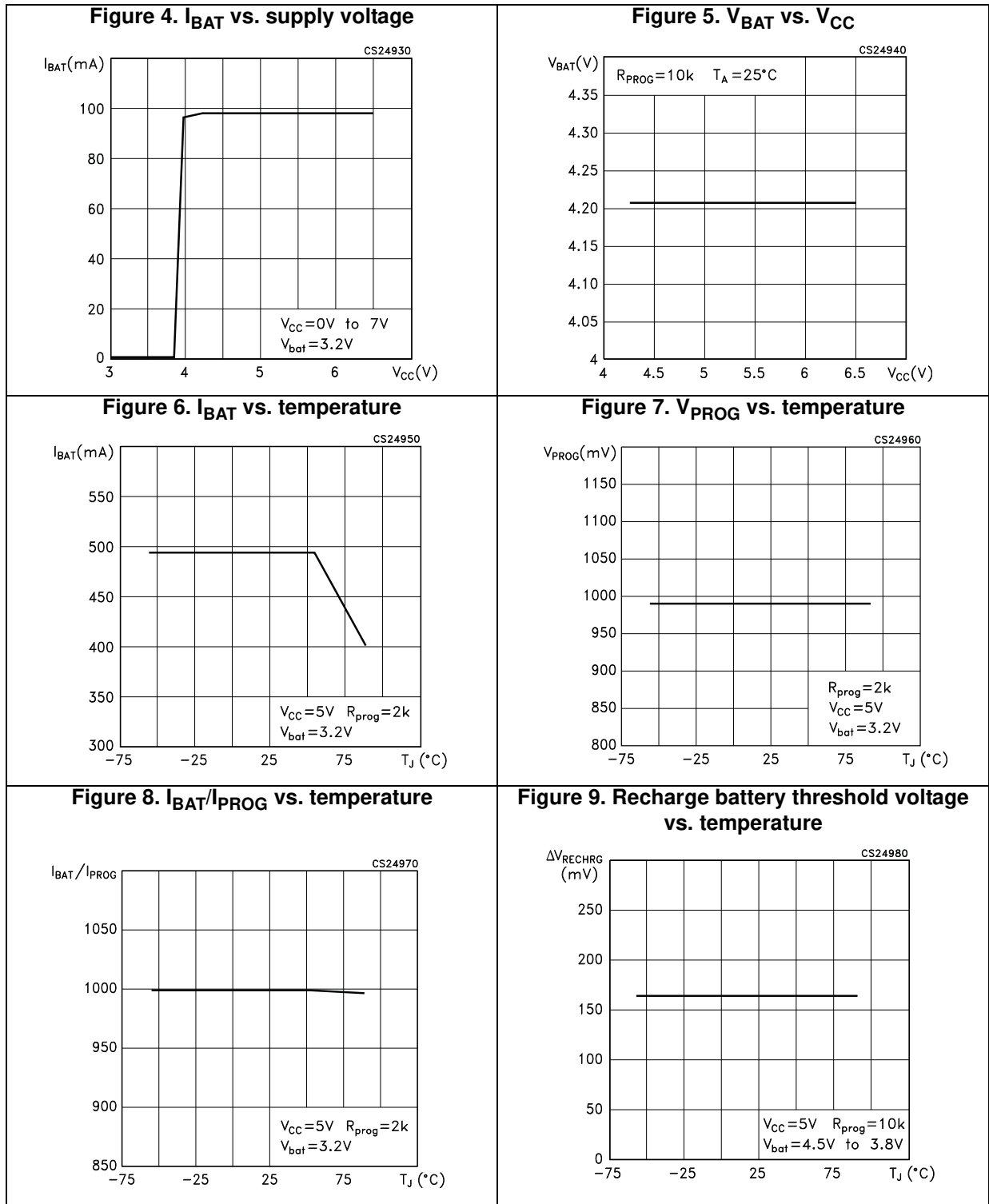

Figure 10. I_{BAT}/I_{PROG} vs. V_{CC}

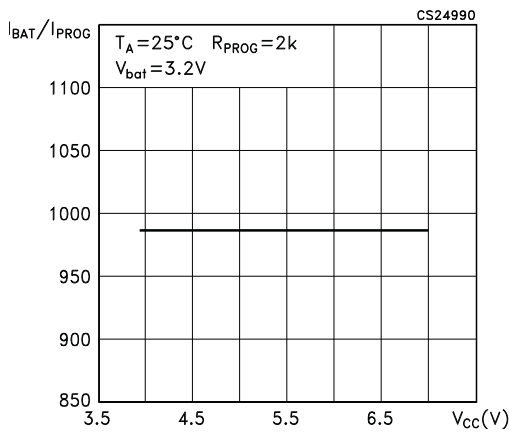

Figure 11. I_{BAT} vs. V_{BAT}

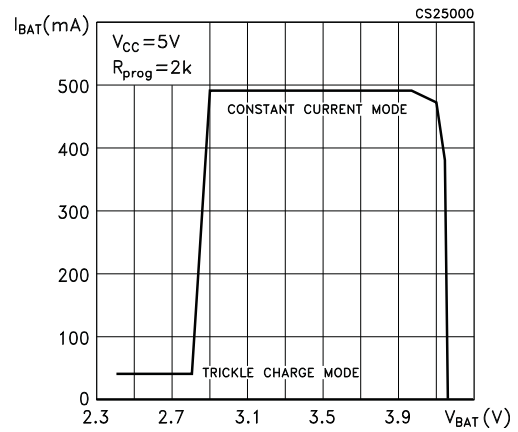

Figure 12. V_{CHRG} vs. temperature (CHRG pin output low voltage)

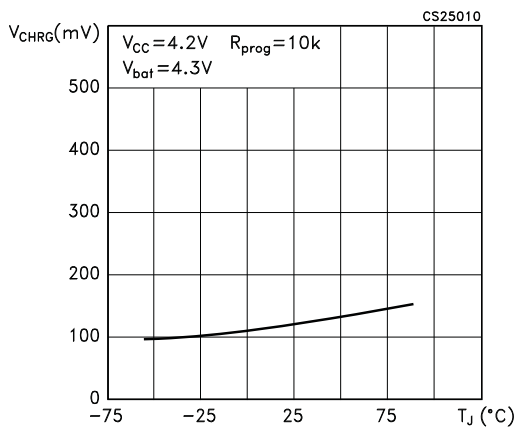

Figure 13. I_{BAT} vs. V_{PROG}

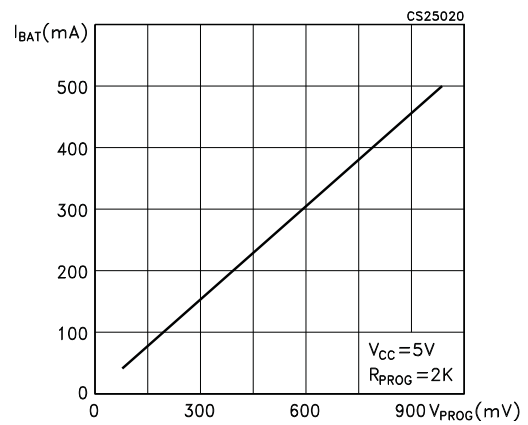
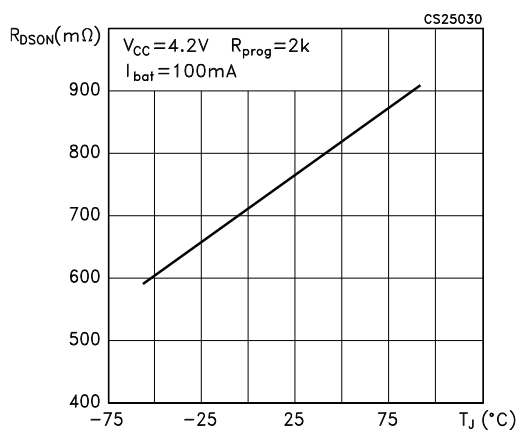

Figure 14. Power FET on-resistance



6 Application information

The STBC08 uses an internal P-channel MOSFET to work in constant current and constant voltage method. It provides up to 800 mA with a final regulated output voltage of 4.2 V \pm 1% in full temperature range. Neither blocking diode nor sensing resistor are required. The USB port can be used as a power supply voltage.

6.1 Charge cycle

A charge cycle begins when the voltage at the V_{CC} pin rises above UVLO threshold level, R_{PROG} program resistor of 1% is connected between PROG pin and GND pin and when a battery is connected to the charger output. If the battery voltage is below 2.9 V, the charger enters trickle charge mode. In this condition, the device supplies 1/10th of the programmed charge current to keep the battery voltage in a safe level otherwise the life of a battery reduces. If BAT pin voltage is higher than 2.9 V the charger goes to constant current mode. When BAT pin voltage is close to the final float voltage (4.2 V) the device goes to constant voltage mode and the charge current begins decreasing. The charge cycle is over when the current drops 1/10th of the programmed value.

6.2 V_{CC} pin

Input supply voltage is used to supply the device in the range from 4.25 V to 6.5 V voltage. A bypass capacitor of 1 μ F is recommended. When V_{CC} value drops below 30 mV of BAT pin voltage, the device goes to shutdown mode, dropping I_{BAT} less than 2 μ A.

6.3 POWER ON pin

POWER ON pin is an open drain flag indicating V_{CC} presence, $V_{UVLO} < V_{CC} < 7.2$ V and $V_{CC} > V_{BAT}$. While in high impedance, it indicates that $V_{CC} < V_{UVLO}$, $V_{CC} > 7.2$ V or $V_{CC} < V_{BAT}$. In high impedance status V_{CC} doesn't start the charge cycle.

6.4 CHRNG pin

CHRNG pin is an open drain flag indicating the status of the charge. When the pin is in low-state, the device charges the battery. If the pin is in high impedance state the charge is over.

Table 6. Flag status values for CHRNG pin

POWER ON	CHRNG	Description
0	0	Pre-charge mode (trickle charge mode) or charge mode. V_{CC} is higher than V_{UVLO} and R_{PROG} is connected to PROG pin.
0	1 ⁽¹⁾	Standby mode (charge completed) or shutdown mode (R_{PROG} not connected).
1 ⁽¹⁾	1 ⁽¹⁾	Supply is not sufficient.

1. Output pin in high impedance (external pull-up needed).

6.5 PROG pin

Charge current program, charge current monitor and shutdown pin. The charge current is programmed by connecting a resistor of 1%, R_{PROG} , to ground. When the device charges in constant current, the voltage value of this pin is 1.0 V. In other conditions, the voltage on this pin can measure the charge current thanks to the following formula:

Equation 1

$$I_{BAT} = (V_{PROG}/R_{PROG}) * 1000$$

PROG pin shuts down the device; disconnecting the program resistor from ground, the current of 1 μ A flows to pull PROG pin high. If the value of this pin is 1.21 V (shutdown threshold voltage), the device enters shutdown mode and the input supply current drops to 25 μ A. Driving this pin to voltage beyond 2.4 V, a current of 35 μ A flows to the device from PROG pin.

6.6 Programming charge current

R_{PROG} resistor sets the charge current value. The battery charge current is 1000 times the PROG pin current value. The program resistor and the charge current are calculated according to the following equation:

Equation 2

$$R_{PROG} = 1000 * V_{PROG} / I_{BAT}$$

The charge current out of BAT pin can be monitored by PROG pin voltage as per below equation:

Equation 3

$$I_{BAT} = (V_{PROG}/R_{PROG}) * 1000$$

6.7 BAT pin

The charge current output pin provides the battery with charge current and regulates the final float voltage to 4.2 V. An internal resistor is a feedback loop, which compares V_O with the reference.

6.8 Charge termination

A charge cycle is terminated when the final float voltage is reached while the charge current falls $1/10^{\text{th}}$ of the programmed value. The charge is over when PROG pin voltage falls below 100 mV for a time longer than t_{TERM} (~ 1 ms). The charge current is latched off, the device is in standby mode and the input supply current drops to 200 μA .

6.9 Automatic recharge

The device restarts the charge cycle when the battery voltage falls below 4.05 V to maintain the battery capacity value higher than 80%. During the recharge time, CHRG pin goes to low-state.

6.10 Soft-start

When a charge cycle starts, an internal soft-start circuit minimizes the inrush current. At starting phase, the charge current ramps from zero to full scale in 100 μs .

6.11 Thermal regulation

An internal thermal feedback loop reduces the output current if the die temperature rises above a present value of approximately 120 $^{\circ}\text{C}$. This feature protects the device from the excessive temperature and allows the user to push the limits of the power handling the capability of a given circuit board without damaging the device.

6.12 Power dissipation

A good thermal PC board layout should be used to maximize the available output current. The thermal path for the heat generated by IC is from the die to the copper lead frame through the package leads and exposed pad to the PC board copper.

The PC board copper is the heat sink. Footprint copper pads should be as wider as possible and expand out to larger copper areas to spread and dissipate the heat to the surrounding ambient. Feed-through vias to inner or backside copper layers are also useful to improve the overall thermal performance of the device. Other heat sources on the board, not related to the device, have to be considered when a PC board layout is designed because they affect the overall temperature rise and the maximum output current.

6.13 Stability considerations

The STBC08 contains two control loops: the constant voltage and the constant current. The constant voltage loop is stable without any compensation when a battery is connected with low impedance leads. Excessive lead length, however, may add enough parasitic series inductance to require 1 μF bypass capacitor from BAT to GND. Furthermore, a 4.7 μF capacitor with a series resistor (0.2 Ω to 1 Ω) from BAT to GND is required to keep ripple voltage low when the battery is disconnected.

7 Package mechanical data

In order to meet environmental requirements, ST offers these devices in different grades of ECOPACK[®] packages, depending on their level of environmental compliance. ECOPACK[®] specifications, grade definitions and product status are available at: www.st.com. ECOPACK[®] is an ST trademark.

Figure 15. DFN6 (3x3 mm) drawings

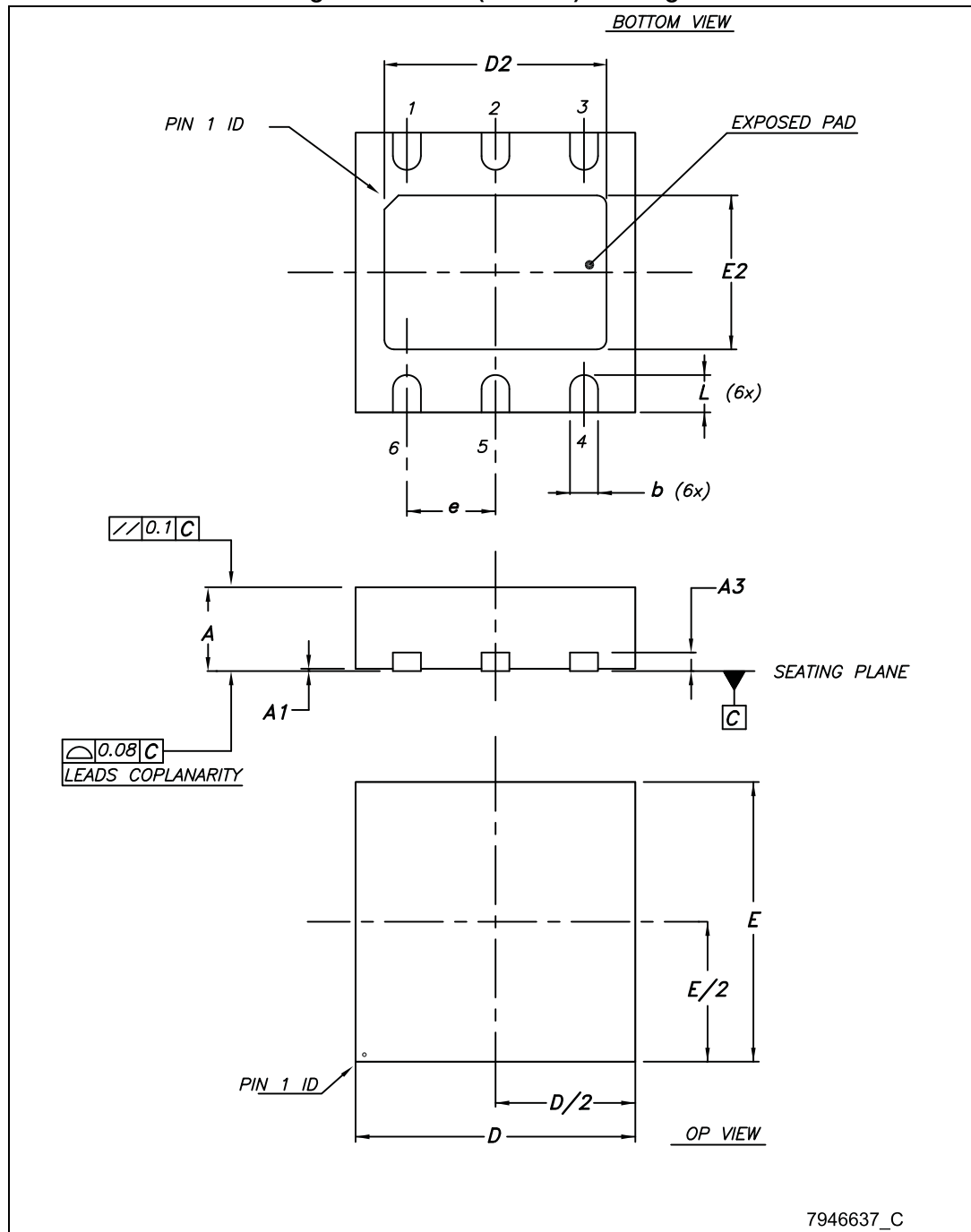
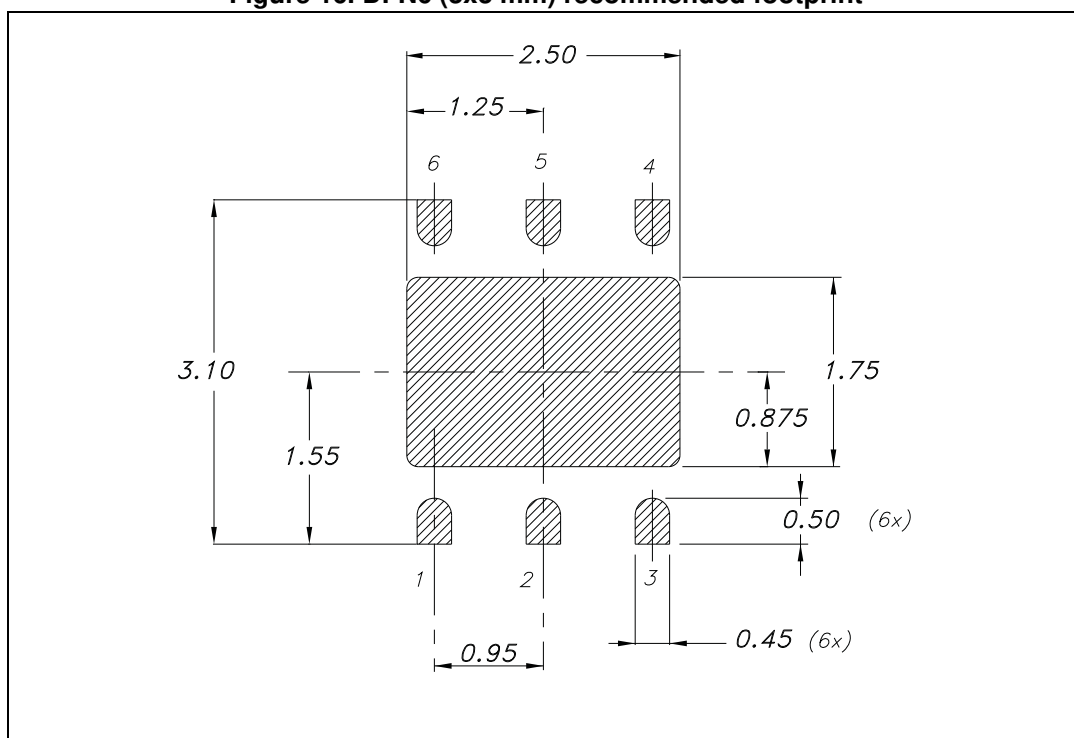

Table 7. DFN6 (3x3 mm) mechanical data

Dim.	mm		
	Min.	Typ.	Max.
A	0.80		1
A1	0	0.02	0.05
A3		0.20	
b	0.23		0.45
D	2.90	3	3.10
D2	2.23		2.50
E	2.90	3	3.10
E2	1.50		1.75
		0.95	
L	0.30	0.40	0.50

Figure 16. DFN6 (3x3 mm) recommended footprint



8 Packaging mechanical data

Figure 17. DFN6 (3x3 mm) tape

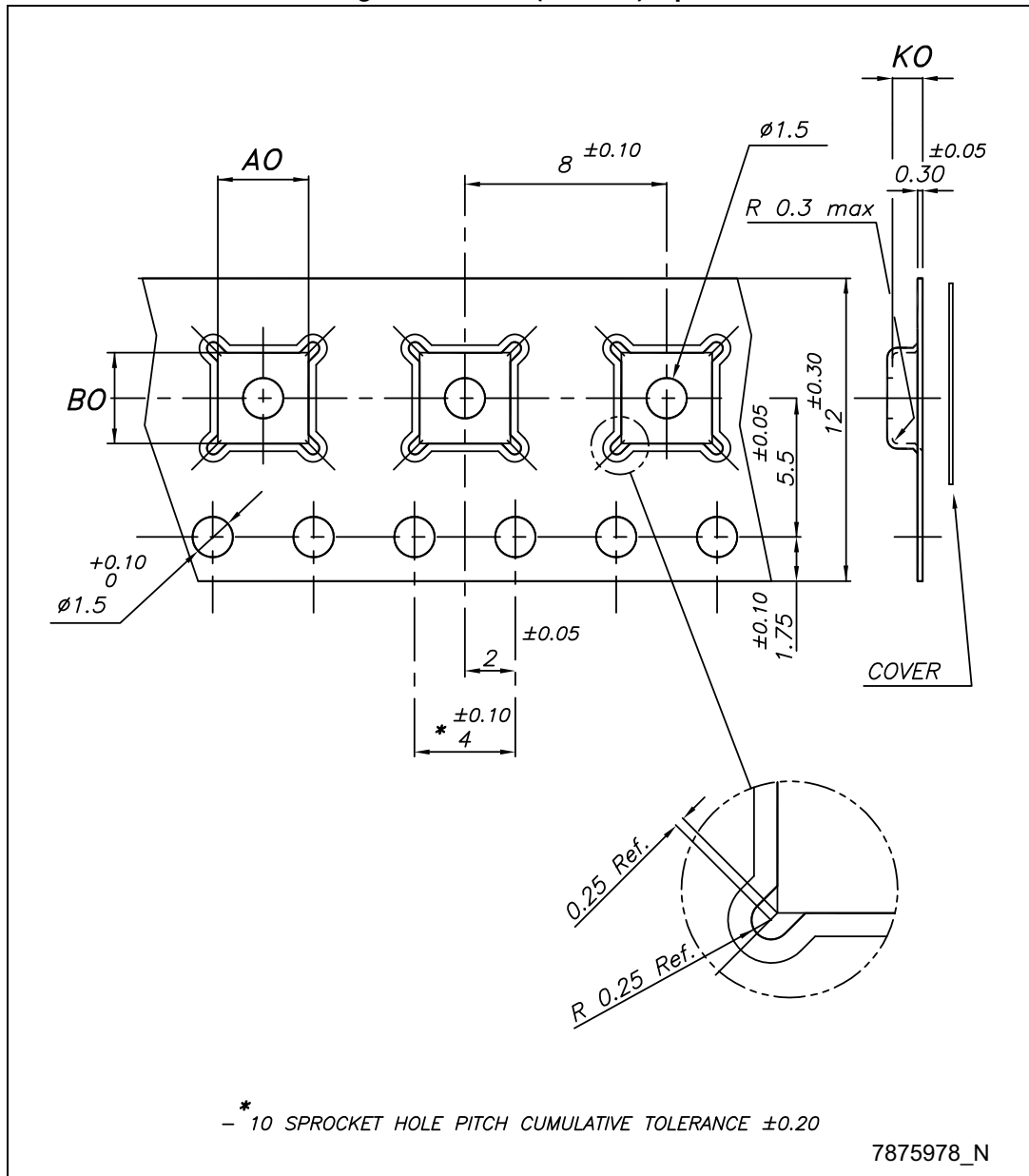

Figure 18. DFN6 (3x3 mm) reel

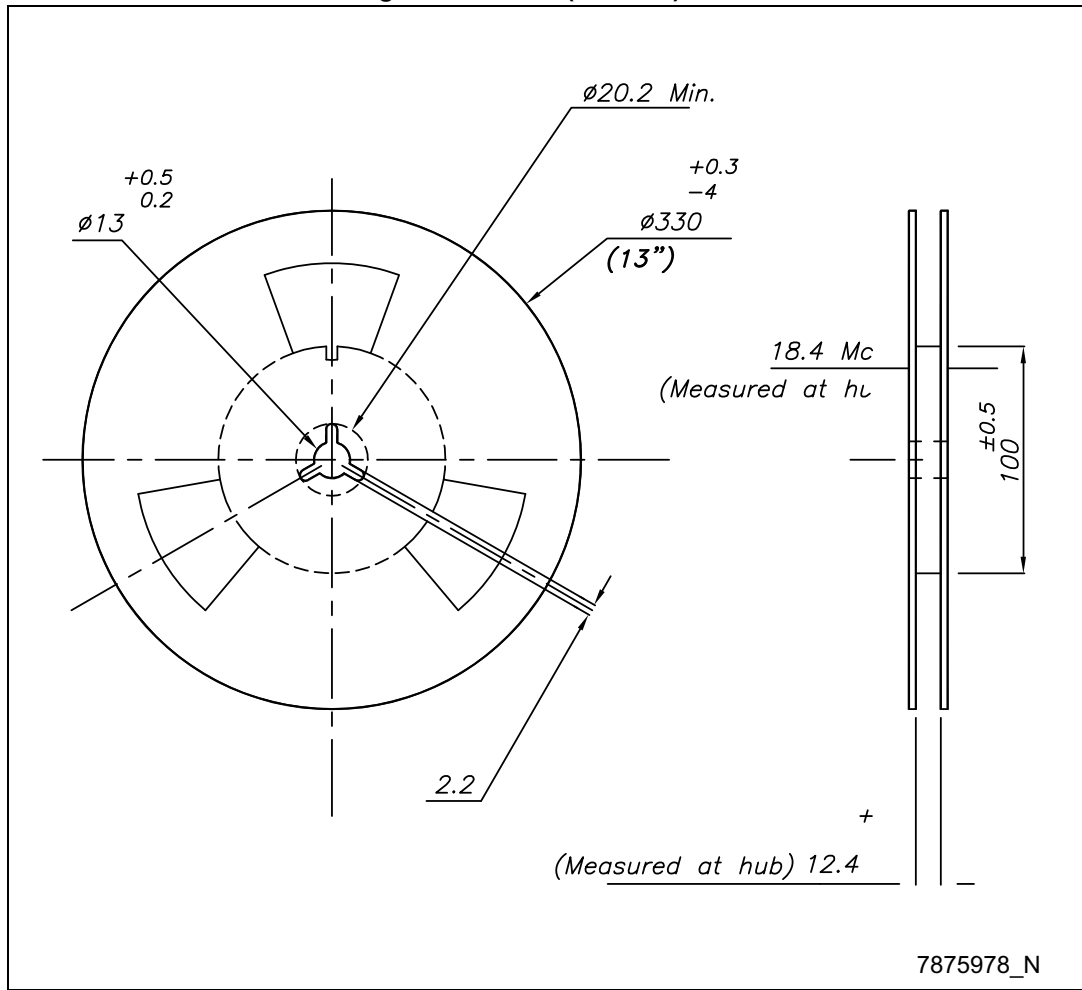

Table 8. DFN6 (3x3 mm) tape and reel mechanical data

Dim.	mm		
	Min.	Typ.	Max.
A0	3.20	3.30	3.40
B0	3.20	3.30	3.40
K0	1	1.10	1.20

9 Revision history

Table 9. Document revision history

Date	Revision	Changes
04-Sep-2006	1	Initial release.
29-May-2014	2	Added exposed pad pin to Table 2 . Updated I _{TERM} parameter in Table 5 . Modified Table 6 . Minor text changes.

Please Read Carefully:

Information in this document is provided solely in connection with ST products. STMicroelectronics NV and its subsidiaries ("ST") reserve the right to make changes, corrections, modifications or improvements, to this document, and the products and services described herein at any time, without notice.

All ST products are sold pursuant to ST's terms and conditions of sale.

Purchasers are solely responsible for the choice, selection and use of the ST products and services described herein, and ST assumes no liability whatsoever relating to the choice, selection or use of the ST products and services described herein.

No license, express or implied, by estoppel or otherwise, to any intellectual property rights is granted under this document. If any part of this document refers to any third party products or services it shall not be deemed a license grant by ST for the use of such third party products or services, or any intellectual property contained therein or considered as a warranty covering the use in any manner whatsoever of such third party products or services or any intellectual property contained therein.

UNLESS OTHERWISE SET FORTH IN ST'S TERMS AND CONDITIONS OF SALE ST DISCLAIMS ANY EXPRESS OR IMPLIED WARRANTY WITH RESPECT TO THE USE AND/OR SALE OF ST PRODUCTS INCLUDING WITHOUT LIMITATION IMPLIED WARRANTIES OF MERCHANTABILITY, FITNESS FOR A PARTICULAR PURPOSE (AND THEIR EQUIVALENTS UNDER THE LAWS OF ANY JURISDICTION), OR INFRINGEMENT OF ANY PATENT, COPYRIGHT OR OTHER INTELLECTUAL PROPERTY RIGHT.

ST PRODUCTS ARE NOT DESIGNED OR AUTHORIZED FOR USE IN: (A) SAFETY CRITICAL APPLICATIONS SUCH AS LIFE SUPPORTING, ACTIVE IMPLANTED DEVICES OR SYSTEMS WITH PRODUCT FUNCTIONAL SAFETY REQUIREMENTS; (B) AERONAUTIC APPLICATIONS; (C) AUTOMOTIVE APPLICATIONS OR ENVIRONMENTS, AND/OR (D) AEROSPACE APPLICATIONS OR ENVIRONMENTS. WHERE ST PRODUCTS ARE NOT DESIGNED FOR SUCH USE, THE PURCHASER SHALL USE PRODUCTS AT PURCHASER'S SOLE RISK, EVEN IF ST HAS BEEN INFORMED IN WRITING OF SUCH USAGE, UNLESS A PRODUCT IS EXPRESSLY DESIGNATED BY ST AS BEING INTENDED FOR "AUTOMOTIVE, AUTOMOTIVE SAFETY OR MEDICAL" INDUSTRY DOMAINS ACCORDING TO ST PRODUCT DESIGN SPECIFICATIONS. PRODUCTS FORMALLY ESCC, QML OR JAN QUALIFIED ARE DEEMED SUITABLE FOR USE IN AEROSPACE BY THE CORRESPONDING GOVERNMENTAL AGENCY.

Resale of ST products with provisions different from the statements and/or technical features set forth in this document shall immediately void any warranty granted by ST for the ST product or service described herein and shall not create or extend in any manner whatsoever, any liability of ST.

ST and the ST logo are trademarks or registered trademarks of ST in various countries.

Information in this document supersedes and replaces all information previously supplied.

The ST logo is a registered trademark of STMicroelectronics. All other names are the property of their respective owners.

© 2014 STMicroelectronics - All rights reserved

STMicroelectronics group of companies

Australia - Belgium - Brazil - Canada - China - Czech Republic - Finland - France - Germany - Hong Kong - India - Israel - Italy - Japan - Malaysia - Malta - Morocco - Philippines - Singapore - Spain - Sweden - Switzerland - United Kingdom - United States of America

www.st.com