



Chipsmall Limited consists of a professional team with an average of over 10 year of expertise in the distribution of electronic components. Based in Hongkong, we have already established firm and mutual-benefit business relationships with customers from,Europe,America and south Asia,supplying obsolete and hard-to-find components to meet their specific needs.

With the principle of “Quality Parts,Customers Priority,Honest Operation,and Considerate Service”,our business mainly focus on the distribution of electronic components. Line cards we deal with include Microchip,ALPS,ROHM,Xilinx,Pulse,ON,Everlight and Freescale. Main products comprise IC,Modules,Potentiometer,IC Socket,Relay,Connector.Our parts cover such applications as commercial,industrial, and automotives areas.

We are looking forward to setting up business relationship with you and hope to provide you with the best service and solution. Let us make a better world for our industry!



Contact us

Tel: +86-755-8981 8866 Fax: +86-755-8427 6832

Email & Skype: info@chipsmall.com Web: www.chipsmall.com

Address: A1208, Overseas Decoration Building, #122 Zhenhua RD., Futian, Shenzhen, China





HOME APPLIANCE CONTROL CIRCUIT

APPLICATIONS

- Home Appliance digital control
- AC Power drive and functional safety management
- Air Conditioner, Refrigerator and Oven applications
- Compressor, fan, heater and valve drive circuit

FEATURES

- Wide range input supply voltage operation: 7 to 18V
- 5 V +/- 5% full tolerance voltage regulator and 50mA output current
- MCU reset circuit with activation delay time and hysteresis (3.75V Hi, 3.4V Lo)
- 30µs digitally filtered inverting Zero Voltage Synchronization
- Three 50mA relay coil drivers with demagnetizing diode
- One 150mA relay coil driver with demagnetizing diode for a 20A relay
- One 30mA peak enhanced buzzer driver with enable pin and soft turn off
- 12 to 5V robust non inverting level shifter for speed sensor or door switch interface
- Ambient temperature: - 20 to 85°C

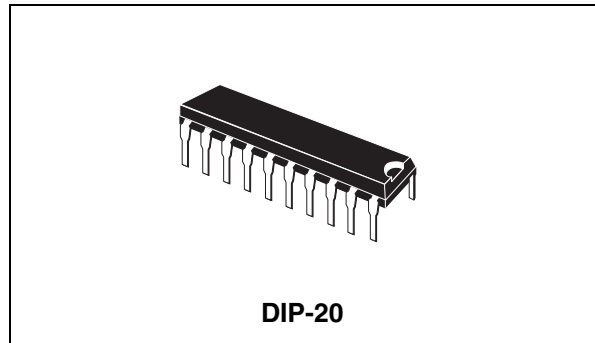

DIP-20

Table 1. Order Code

Part Number	Marking
STCC05-BD4	STCC05-B

BENEFITS

- Higher module compactness with reduced component count
- Drastic reduction of soldered pins on the board for lower use of lead metal
- Faster module assembly time
- High transient burst immunity and ESD robustness compliant with IEC61000-4 standards
- Enhanced functional reliability
- Enhanced circuit parametric quality
- Easy to design for short time to market

Figure 1: STCC05 based Air Conditioner application diagram

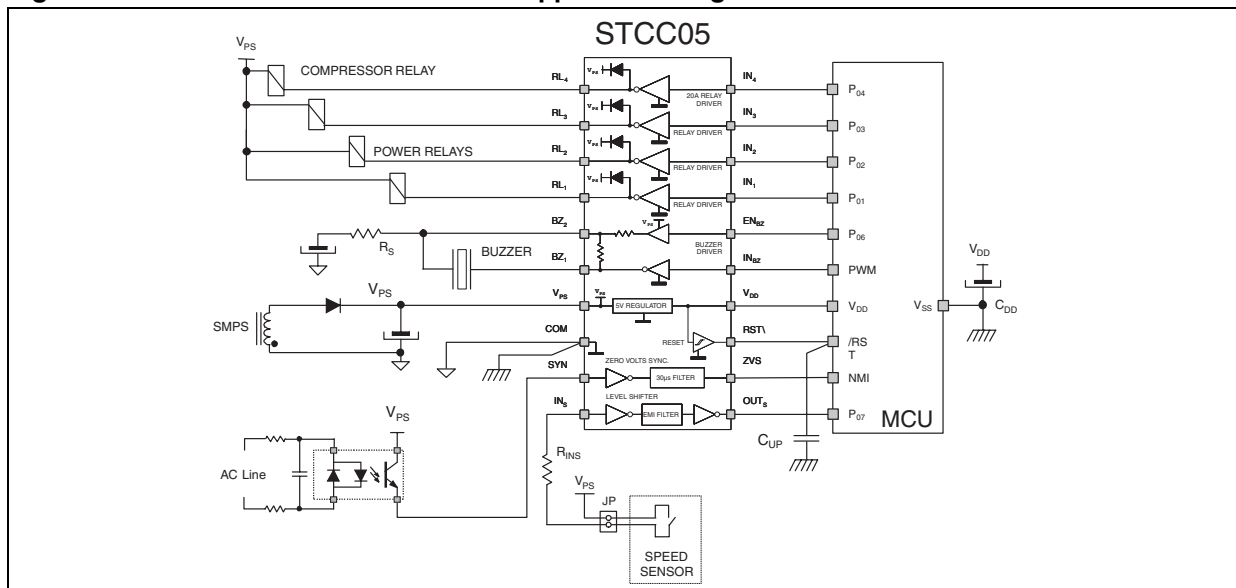

Figure 2. Block diagram

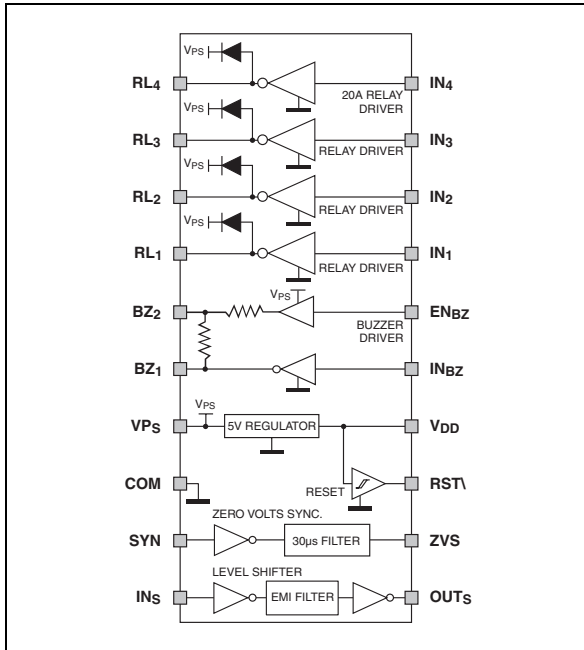
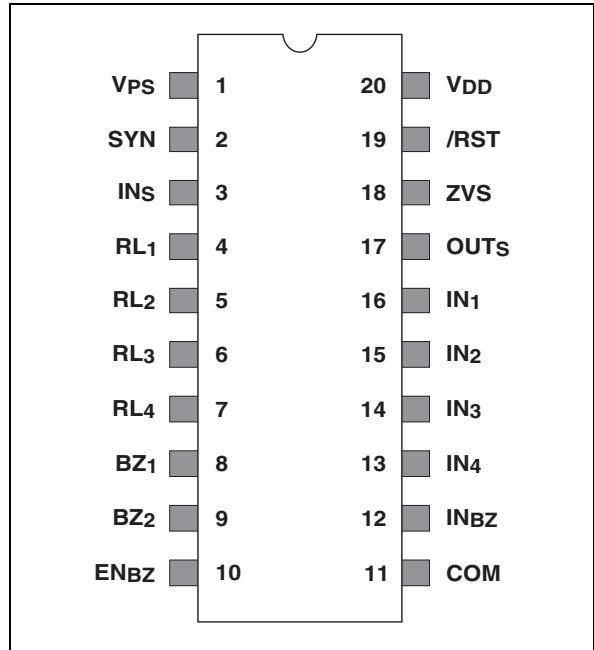

Figure 3. Pin-out connections



FUNCTIONAL DESCRIPTION

The STCC05 is a control circuit embedding most of the analog & power circuitry of an air conditioner or refrigerator control module. It interfaces the micro-controller MCU with the AC power and cooling process sections.

■ **The voltage supply**

The 5V voltage regulator supplies the micro-controller MCU. Its input voltage ranges from 7V to 18V; and its average DC output current up to 50mA. With an output filtering capacitor of 100µF, its output voltage accuracy is better than +/- 5% in the whole operating range of the ambient temperature T_{AMB} , the load current I_{DD} and the input voltage V_{PS} , contributing directly to the ADC accuracy.

The regulator includes also an over current limiter and a thermal shutdown. The over current limiter protects the regulator against output short circuits and inrush currents during the power up. The current limiter is made of a serial shunt resistance as current sensor and a circuit that regulates the input current. Moreover, the thermal shutdown protects the whole circuit against overload operations. It is made of a thermal sensing junction and a hysteresis comparator that is able to switch off the passing element.

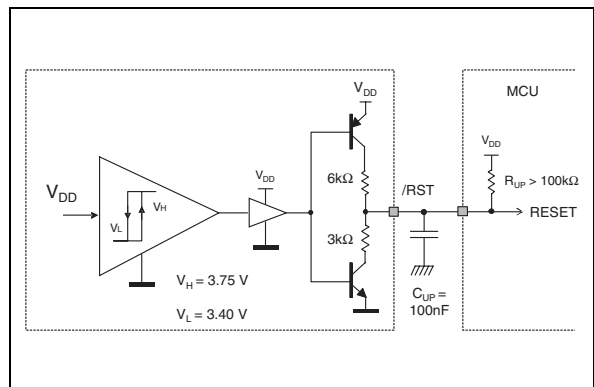
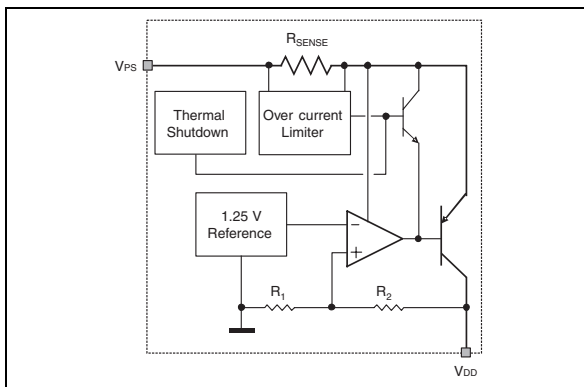

■ The reset circuit

This circuit ensures a Low Voltage Detection (LVD) of the output of the regulator. Most micro-controllers have an active RESET pin in the low state: so, the /RST pin will be active at low state.

The reset comparator senses the regulator voltage V_{DD} . The /RST pin goes high when V_{DD} is higher than the high threshold $V_H = 3.75V$ and after a delay time T_{UP} ; and is low when the V_{DD} decreases below the low threshold $V_L = 3.4V$ after the delay time T_{DW} .

These delays are set by an external capacitor C_{UP} connected to the /RST pin and depend on the trigger thresholds of /RST: For $C_{UP} = 100nF$, $T_{UP} = 400\mu s$ with $V_{TH} = V_H/2$; $T_{DW} = 200\mu s$ with $V_{TH} = V_L/2$.

■ The Zero Voltage Synchronization ZVS circuit

The Zero Voltage Synchronization ZVS circuit generates the signal ZVS that synchronizes the whole operation with the AC line cycle (20 ms on 50 Hz or 16.7 ms on 60 Hz). This signal allows the MCU to control the AC loads and achieve the timing functions.

The input pin SYN is an image of the mains voltage. It is connected to either the power supply transformer through a resistor R_{ZV} or an opto-coupler that is controlled directly by the AC line voltage. The circuit is protected against fast line transient voltages: a robust ESD protection and a $30\mu s$ digital filter are implemented to provide a higher immunity to the MCU operation. Its output signal ZVS is inverted respect to the input signal V_{SYN} .

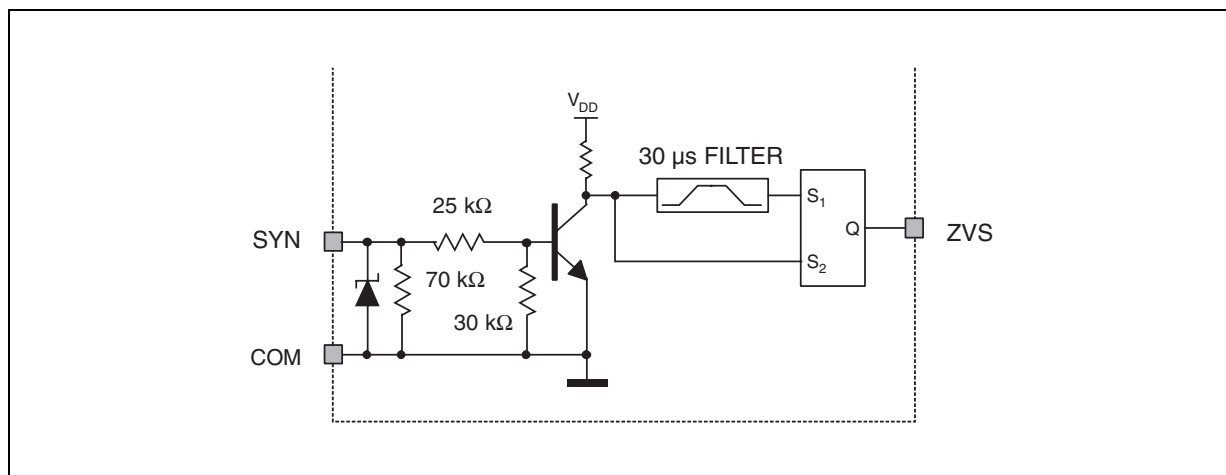

■ The relay coil drivers

These robust circuits allow a DC relay coil to be driven by an MCU output. The relay coil has a minimum resistance of 580Ω and has a power up to $0.25W$ for $V_{PS} = 12V$. These characteristics are representative of 3A relays such as FTR-F3AA-12V or JQ1A-12V series.

The output stage is made of a transistor and a demagnetization diode. The transistor is referred to the ground COM, has a DC current rating of $50mA$; and its collector is connected to the output RL_i ($i=1, 2, 3$). The diode is connected between the output pin RL_i and the supply pin V_{PS} .

Moreover, a fourth coil driver has an extended $150mA$ current capability to be able to drive the coil of a relay having a 130Ω minimum resistance and a $1.1W$ maximum power. These characteristics are representative of 20A relays such as G4A-E-DC12, OMIF-S-112 or UKH12S series.

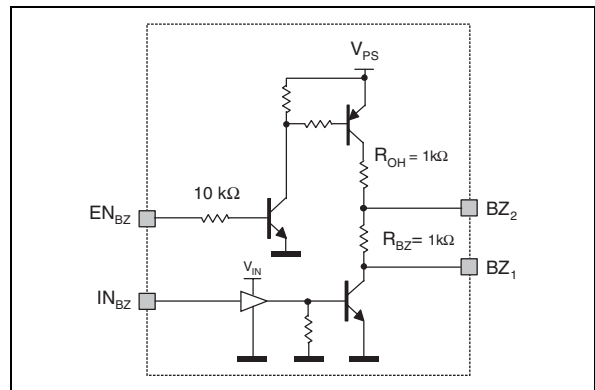
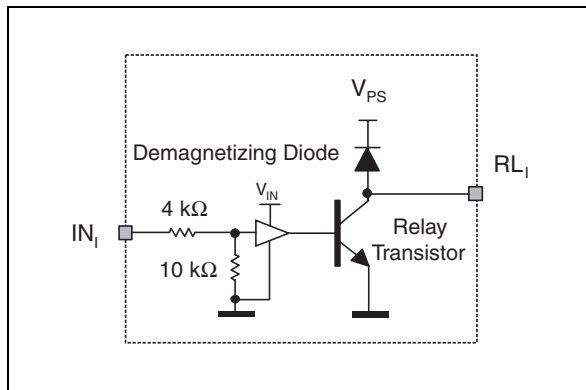

■ **The buzzer driver with enable control**

The MCU can excite a warning buzzer with a 50% PWM signal. The buzzer driver amplifies this signal in current and translates it from the 5V MCU output to the V_{PS} supply to produce the right sound level from the buzzer.

The output stage is made of a NPN transistor, a PNP transistor and two 1kΩ resistors.

The NPN transistor, referred to the power ground COM, is controlled by the input IN_{BZ} ; its collector is connected to the output BZ_1 . The input IN_{BZ} is driven by a simple push-pull MCU buffer.

The PNP transistor, referred to the V_{PS} polarity, is controlled by the input EN_{BZ} ; and its collector is connected to the output BZ_2 through a 1kΩ resistor. The input EN_{BZ} is driven by a simple push-pull MCU buffer.

The pin BZ_2 is the supply terminal of the buzzer; and the circuit has a DC current rating of 9mA and the PWM section runs from 10Hz up to 5kHz.

A 1kΩ resistor R_{BZ} is connected between the BZ_1 and BZ_2 pins to discharge the buzzer periodically. Moreover, the addition of an external capacitor-resistor network on BZ_2 pin will allow the buzzer to turn on and off smoothly when the pin EN_{BZ} is toggling.

■ **The speed sensor level shifter**

The OUT_S signal is generated by an electronic signal such as the indoor fan speed clock issued of a Hall Effect sensor or a door switch signal and is transmitted to the MCU. As the IN_S input may be disturbed; a spike suppressor and a simple EMI filter are added to increase the input robustness. The output signal OUT_S is not inverted with respect to the input signal IN_S .

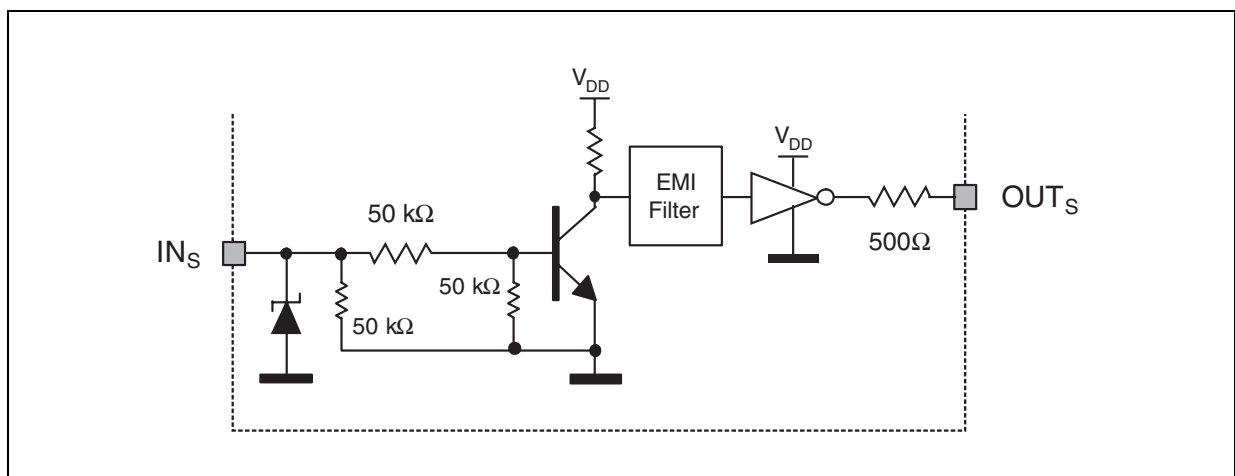

Table 2: Absolute Ratings (limiting values)

Symbol	Pin	Parameter name & conditions	Value	Unit
V _{DD}	V _{DD}	Output supply voltage	- 0.3 to 6	V
V _{PS}	V _{PS} , IN _S	Power supply voltage, level shifter input	- 0.3 to 20	V
V _{SYN}	SYN	ZVS input voltage, R _{ZV} = 15kΩ	- 1 to 20	V
V _{MO}	BZ ₁ , BZ ₂ , RL _x , x = 1 to 4	Output voltage	- 0.3 to V _{PS} + 0.3	V
V _I	IN ₁ , IN ₂ , IN ₃	Input logic voltage	- 0.3 to V _{DD} + 0.3	V
V _O	ZVS, OUT _S , /RST	Output logic voltage	- 0.3 to V _{DD} + 0.3	V
I _M	V _{PS}	Maximum sourced current pulse, tp = 10ms	500	mA
	RL _x , x = 1 to 3	Maximum sunk driver current pulse, tp = 10ms	60	mA
		Maximum DC sunk current	50	mA
	RL ₄	Maximum sunk driver current pulse, tp = 10ms	160	mA
		Maximum DC sunk current	150	mA
RL _x , x = 1 to 4	Maximum diver diode reverse current	1	mA	
I _{BZ AV}	BZ ₁ , BZ ₂	Average output current	± 2	mA
I _{BZ PK}	BZ ₁ , BZ ₂	Peak output current, tp = 50μs	± 50	mA
ΣI _M	RL _x , l = 1 to 4	Maximum DC sunk current in all relay drivers V _{PS} = 16V, T _{AMB} = 70°C, I _{DD} = 50mA, DIP-20	220	mA
		Maximum DC sunk current in all relay drivers V _{PS} = 16V, T _{AMB} = 85°C, I _{DD} = 25mA, DIP-20	300	
P _{DIS}	All	Maximum dissipation, DIP-20, T _{AMB} = 70°C	0.90	W
T _{AMB}	All	Operating ambient temperature	- 20 to 85	°C
T _J	All	Operating junction temperature	- 10 to 150	°C
		Storage junction temperature	- 25 to 150	°C

Table 3: Electromagnetic Compatibility Ratings(T_J = 25°C, according to typical application diagram of page 1, unless otherwise specified)

Symbol	Node	Parameter name & conditions	Value	Unit
V _{ESD}	All pins	ESD protection, MIL-STD 883 method 3015, HBM model	± 2	kV
V _{ESD}	IN _S , SYN, V _{PS} , V _{DD}	ESD protection, IEC 61000-4-2, per input, in air ⁽¹⁾	± 2	
		ESD protection, IEC 61000-4-2, per input, in contact ⁽¹⁾	± 2	
V _{PPB}	All pins	Total peak pulse voltage Burst, IEC 61000-4-4, ⁽²⁾	± 4	

Note 1: System oriented test circuit with R_{ZV} = 15kΩ, R_{INS} = 2.2kΩ and C_{DD} = C_{PS} = 100nF**Note 2:** System oriented test circuit; refer to application section**Table 4: Thermal Resistance**

Symbol	Parameter	Value	Unit
R _{th(j-a)}	DIP-20 thermal resistance junction to ambient Single PCB with a copper thickness = 35μm and surface S _{CU} = 0.5cm ²	90	°C/W

Table 5: Electrical Characteristics ($T_J = 25^\circ\text{C}$, $V_{CC} = 12\text{V}$, unless otherwise specified)

Symbol	Pin	Name	Conditions	Min.	Typ	Max.	Unit
Voltage supply							
V_{DD}	V_{DD}	Output voltage supply	$I_{DD} = 5$ to 40mA $T_{amb} = 0$ to 70°C $V_{PS} = 9$ to 16V $C_{DD} = 100\mu\text{F}$ V_{IN1} to $4 = 0\text{V}$	4.75	5	5.25	V
V_{PS}	V_{PS}	Input supply voltage		7		18	V
I_{SQ}	V_{PS}	Quiescent supply current	$V_{DD} = 5\text{V}$, $I_{DD} = 0$ (open)		1.3	2	mA
I_{IN_SC}	V_{PS}	Limiting input current	$V_{DD} = 0\text{V}$ Output in short circuit	50	80	120	mA
T_{OFF}	V_{DD}	Shutdown temperature			170		$^\circ\text{C}$
ΔT	V	Releasing thermal hysteresis			15		$^\circ\text{C}$
Reset circuit							
V_H	V_{DD}	Disabling reset threshold		3.4	3.75	4	V
V_L		Enabling reset threshold		3.1	3.4	3.6	
V_{HYS}		Threshold hysteresis			0.35		
T_{UP}	/RST	Disabling reset delay time	$C_{UP} = 100\text{nF}$, $V_{TH} = V_H/2$, $R_{UP} = 100\text{k}\Omega$	200	400	800	μs
T_{DW}		Enabling reset delay time	$C_{UP} = 100\text{nF}$, $V_{TH} = V_L/2$, $R_{UP} = 100\text{k}\Omega$	100	200	400	
Zero Voltage synchronization circuit							
T_D	ZVS	Transition filtering time	Rising and falling step	10	30	70	μs
V_{TH}	SYN	Transition threshold		0.6	1.1	1.4	V
I_{SYN}	SYN	Input nominal current	$V_{SYN} = 5\text{V}$		0.3		mA
			$V_{SYN} = 18\text{V}$		0.9	1.5	
Level shifter, zero voltage synchronization, reset circuits							
V_{OH}	LVOOUT /RST	High level output voltage		$0.8 V_{DD}$			V
V_{OL}	ZVS	Low level output voltage				$0.2 V_{DD}$	V
Relay coil drivers							
I_{IN4}	IN_4	Input activating current	$V_{IN4} = 5\text{V}$		0.85	1.4	mA
V_{ON}	RL_4	On state output voltage	$I_{ON} = 150\text{mA}$, $V_{IN4} > 3.1\text{V}$		1	1.2	V
I_{INx}	IN_1 to 3	Input activating current	$V_{INx} = 5\text{V}$		0.85	1.4	mA
V_{ON}	RL_1 to 3	On state output voltage	$I_{ON} = 50\text{mA}$, $V_{INx} > 3.1\text{V}$		1	1.2	V
V_{RLH}	RL_1 to 4	Off state output voltage	$V_{INx} < 50.8\text{V}$, $R_L = 580\Omega$	$0.9 V_{PS}$		V_{PS}	V
V_{INx}	IN_1 to 4	Transition threshold		0.8	1.9	3.1	V
Buzzer driver with enable control							
V_{INBZ}	IN_{BZ}	Input muting voltage		0.8	1.5	3.1	V
F_{BUZ}		Buzzer PWM frequency	Duty cycle = 50%	0.01		5	kHz
R_{OH}	BZ_2	On state output resistance	$V_{INBZ} = 0\text{V}$, $V_{ENBZ} > 3.1\text{V}$, $I_{BZ2} = 5\text{mA}$		1		$\text{k}\Omega$
V_{ON}	BZ_1	On state output voltage	$I_{ON} = 25\text{mA}$, $V_{INBZ} > 3.1\text{V}$, $V_{ENBZ} = 0\text{V}$, $t_p = 50\mu\text{s}$		1	1.4	V
V_{ENBZ}	EN_{BZ}	Enable threshold voltage		0.8	2	3.1	V
R_{BZ}		$BZ_1 - BZ_2$ Buzzer resistance			1		$\text{k}\Omega$
Speed sensor level shifter							
V_{INSH}	INS	High level detection		7		18	V
V_{INSL}		Low level detection				0.8	V
I_{INS}		Internal input current	$V_{INS} = 12\text{V}$			500	800

DC CHARACTERISTICS

Figure 4: Typical regulator voltage V_{DD} variation versus its output current I_{DD} at $T_J = 25^\circ\text{C}$

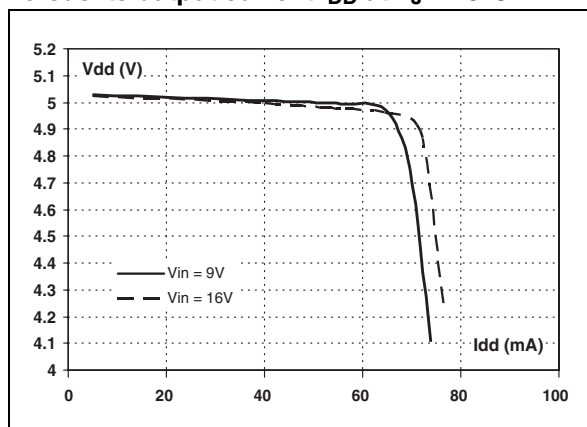

Figure 5: Typical regulator voltage V_{DD} variation versus its junction temperature at $V_{IN} = 12\text{V}$

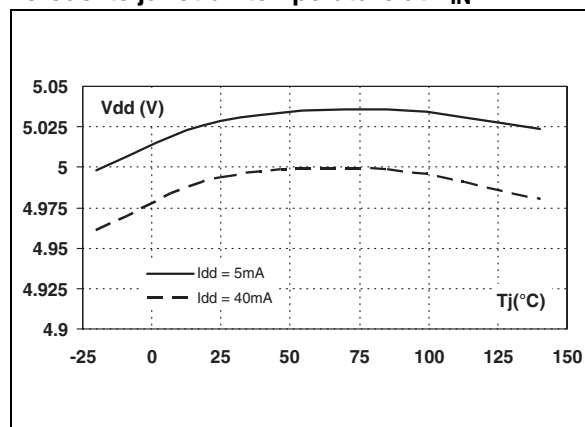

Figure 6: Typical relay driver R_L (1 to 3) on-state voltage variation versus its current

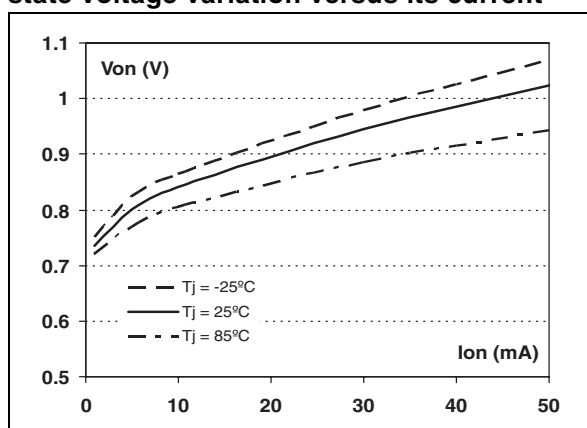
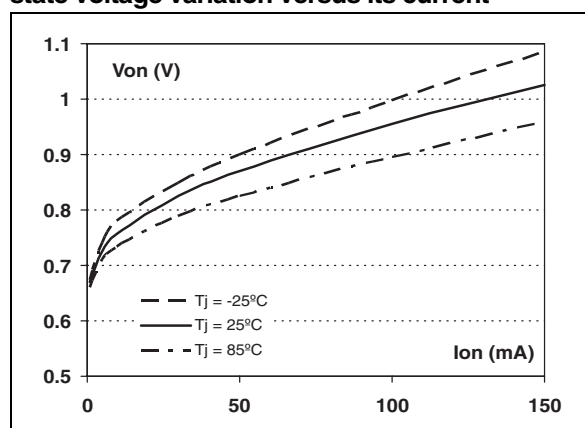

Figure 7: Typical compressor relay driver R_{L4} on-state voltage variation versus its current



AIR CONDITIONER APPLICATION CONSIDERATIONS

■ IMMUNITY IMPROVEMENT OF STCC05 AND THE MICROCONTROLLER

Some basic rules can be applied to improve the STCC05 immunity in its application:

- The power ground of V_{PS} should be split from the signal ground of V_{DD} , (1)
- The STCC05 is placed as close as possible of the MCU, (2)
- The supply capacitors would increase the system immunity by being placed closed to the blocks they feed, or putting decoupling capacitors (f.i. $C_{DD} = C_{PS} = 100\text{nF}$) (3)
- Large supply wire on the PCB should be avoided to reduce sensitivity to radiated interferences.
- A decoupling capacitor can be put on the pin IN_S of the speed sensor interface and the MCU reset pin (4) (f.i. $C_{INS} = 10\text{nF}$; $C_{UP} = 100\text{nF}$).

Depending of the PCB layout quality, others capacitors may be put on sensitive pins such as the output regulator pin V_{DD} and the zero crossing synchronization input pin SYN .

Figure 8: Example of PCB layout improvement for higher immunity

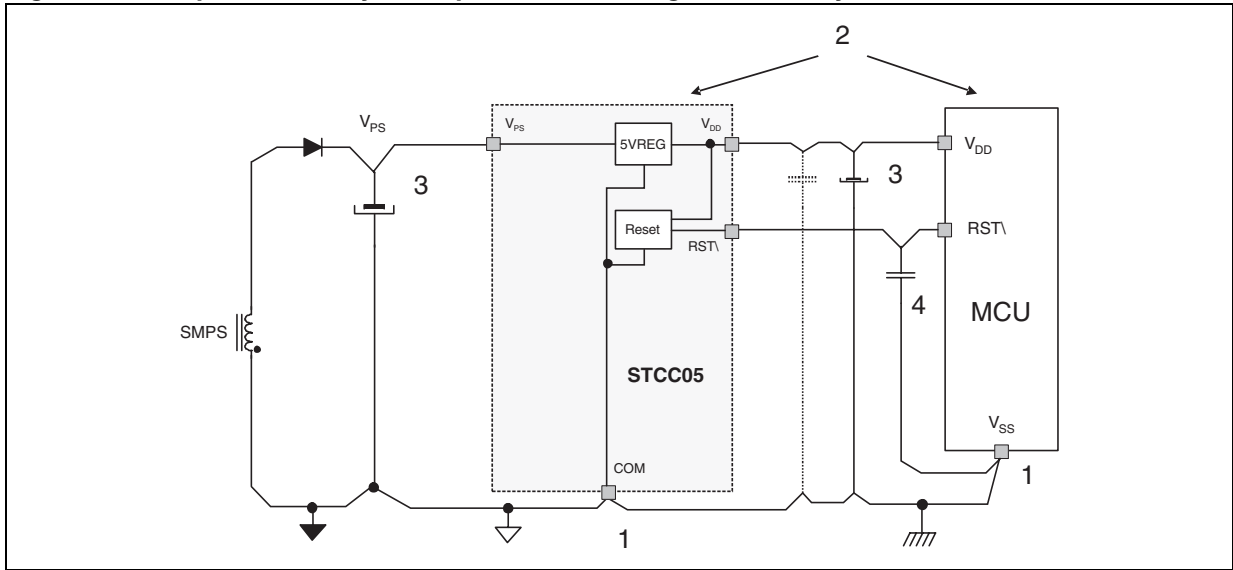

■ STCC05 ELECTROMAGNETIC COMPATIBILITY

Standards such as IEC61000-4-x evaluate the electromagnetic compatibility of appliance systems. To test the immunity level of the STCC05 to the IEC61000-4-4 (Electrical Fast Transient Bursts), a board representative of usual application control unit should be considered by applying the immunity design rules defined in the previous paragraph.

IEC61000-4-4 test does not allow any measurement equipment to be connected to the tested system, as it would corrupt the test results. That is why this board should include a remote monitoring circuit based on optic fibers. Thus, without any electrical link with an oscilloscope, it is possible to monitor the V_{DD} voltage as well as the /RST or the ZVS outputs of the STCC05, during the IEC61000-4-4 test. This optical link detects parasitic commutations of outputs as short as 60ns.

With this board, and the burst generator coupled to the mains as specified in the IEC61000-4-4 standard (see the following principle diagram), the STCC05 has been tested successfully at 4kV.

Figure 9: IEC61000-4-4 Electrical Fast Transient Burst general STCC05 test circuit

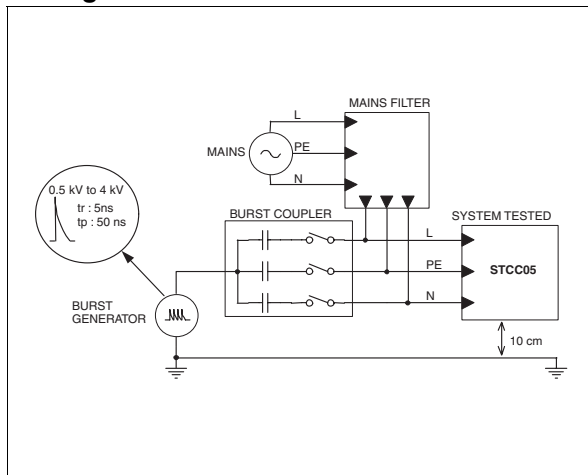
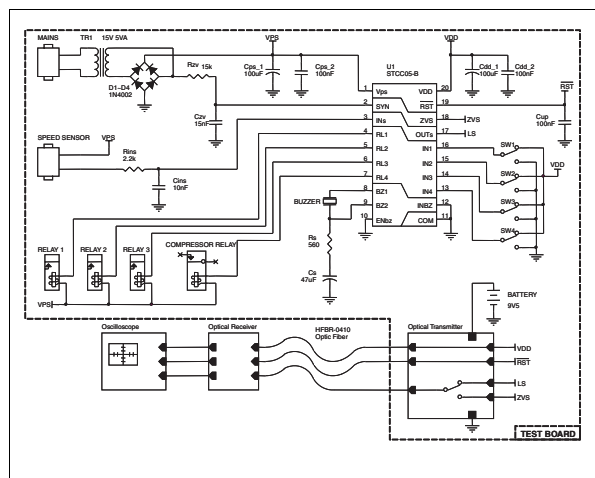

Figure 10: Test circuit schematic



■ STCC05 POWER PERFORMANCE VERSUS ITS THERMAL CAPABILITY

Figure 11: Driver current sum versus regulator current at $T_{AMB} = 85^{\circ}C$ for $V_{PS} = 12, 14, 16, 18V$

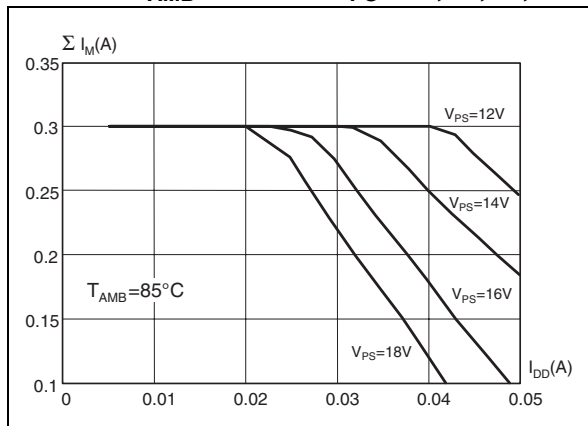
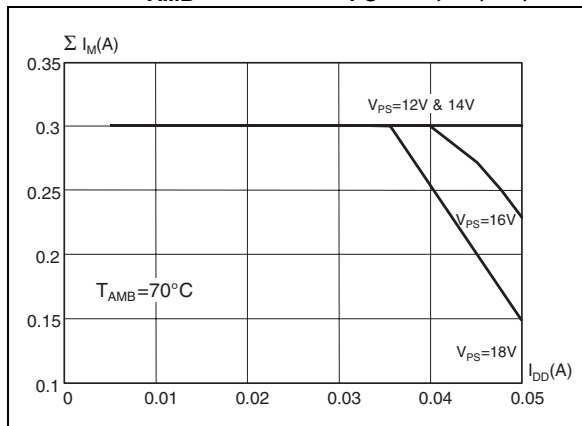

Figure 12: Driver current sum versus regulator current at $T_{AMB} = 70^{\circ}C$ for $V_{PS} = 12, 14, 16, 18V$



The main heat sources of the circuit during operation are the voltage regulator and the relay coil drivers. Depending of the power supply voltage V_{PS} , the ambient temperature T_{AMB} , and the thermal of resistance of the package $R_{th(j-a)}$, the sum of all the coil driver currents ΣI_M is linked to the output regulator current I_{DD} . In order to avoid spurious thermal shutdown of the system, it is advised to respect this relationship as shown on figures 7 and 8.

■ EXTENSION OF THE REGULATOR CURRENT CAPABILITY

The output current capability of the STCC05 voltage regulator can be increased in a cost effective manner by adding an external ballast transistor and two biasing resistors. With such a circuit, the output voltage regulation remains at 5V 5%, and the current limitation is still active. Such a topology generates also power losses in the external power transistor especially when the supply voltage V_{PS} is high or the regulator is in current limiting mode. Therefore it is advised to use a package with a suitable thermal resistance ($R_{th j-a}$).

An example is proposed in the following figure doubling the regulator current capability of the solution to 100mA while producing a current limitation typically at 110mA.

Figure 13: Circuit diagram to extend the STCC05 regulator current to 100mA

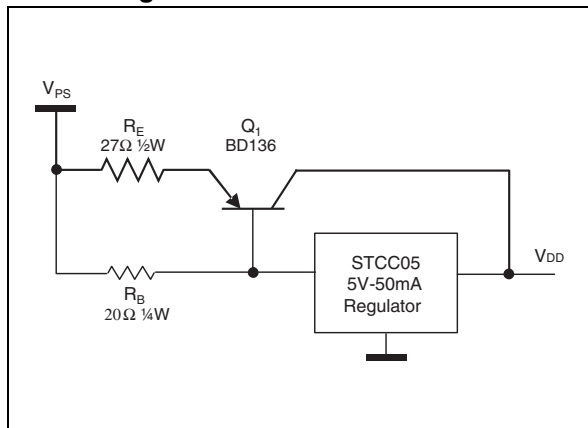
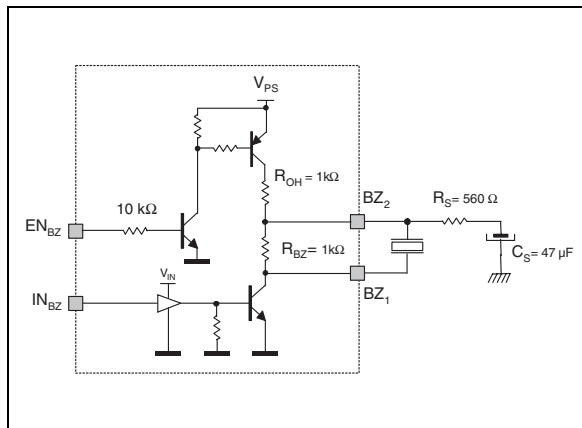

Figure 14: Application diagram of the buzzer drive



■ FLOATING BUZZER OPERATION

The sound produced by the buzzer is controlled by the frequency of the square signal applied to the IN_{BZ} input pin.

The external $R_S C_S$ network connected to the BZ_2 output pin produces a soft sound by smoothing the buzzer supplying envelope at power up and power down. Contrary to basic drivers, which directly apply

the voltage to the buzzer, this circuit feeds the buzzer with the exponential voltage induced by the charge and the discharge of the $R_S C_S$ network.

The R_{OH} and R_S resistors contribute to reduce high harmonic sound distortions. Indeed, they limit the peak current through the buzzer, feed the buzzer with the C_S capacitor voltage, and limit the current through the low side NPN transistor of the driver.

Therefore to set rising/falling durations of the sound shape, it is advised to adjust only the value of the C_S capacitor.

The integrated R_{BZ} resistor is selected to discharge the buzzer when the low side transistor is off, especially at the maximum operating frequency. The buzzer is completely discharged within five times the time constant of the resistor-buzzer with $\tau = R_{BZ} \times C_{BUZZER}$.

Therefore, $R_{BZ} < 1 / (10 \times F_{MAX} \times C_{BUZZER})$. Since the buzzer capacitance C_{BUZZER} is about 20nF at the maximum operating frequency of driver is 5kHz, this R_{BZ} resistance is set at 1k Ω .

Figure 15: Buzzer terminal voltages V_{BZ1} & V_{BZ2} and buzzer current I_{BZ}

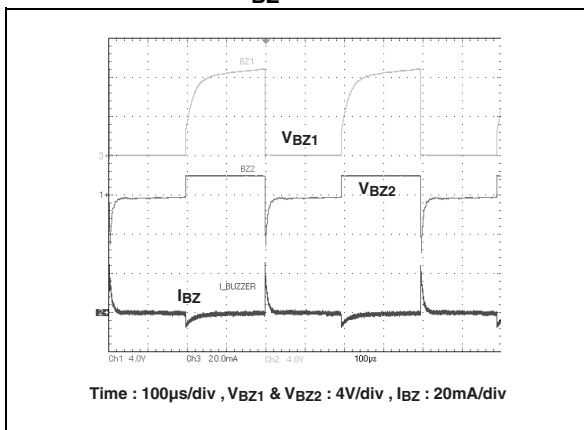
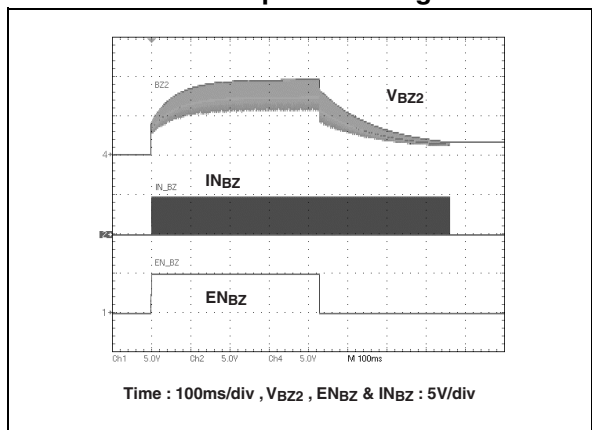

Figure 16: Buzzer terminal voltage V_{BZ2} with buzzer enable and input circuit signals



■ **ZERO CROSSING DETECTION CIRCUITS**

The detection of the zero crossing of the AC line voltage can be achieved at least on two ways with the STCC05, depending of the power supply unit.

When the power supply uses a magnetic 50/60Hz transformer, the input pin SYN is connected to a transformer output through a resistor R_{ZV} , the electrical path being closed by the low side bridge diodes.

Figure 17: ZVS circuit operation using the AC secondary of a transformer

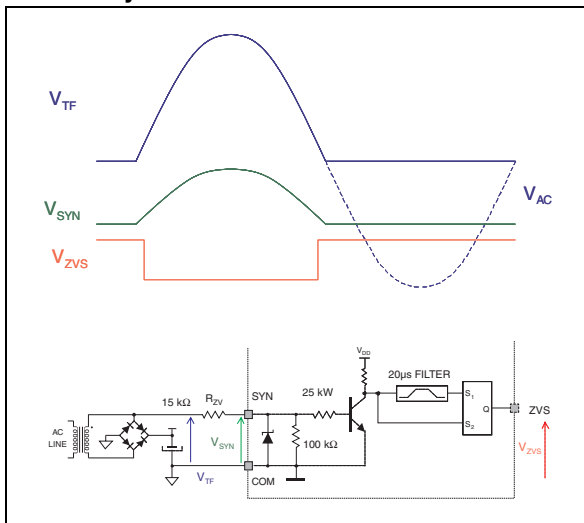

The delay between the real Zero Crossing event and the falling edge of ZVS depends on the internal filtering time, the resistance R_{ZV} , the rectifier drop voltage V_F , the V_{PS} supply load and the temperature. The STCC05 contribution to this delay can be evaluated by measuring the delay between its input voltage V_{TF} and its output voltage V_{ZVS} . When using $V_F = 0.8V$, $R_{ZV} = 15k\Omega$, $V_{PS} = 15V$, $I_{CC} = 20mA$, it is about 50 μs on rising voltage V_{TF} and 115 μs on falling voltage V_{TF} .

When the power supply uses a switch mode power supply, the input pin SYN is synchronized by an opto-coupler, which is connected to the mains terminals through high resistances. The isolator output is on all the time except during the zero crossing where no more current feeds the input and the output transistor switches off.

Finally, the opto-coupler could be connected directly in high side mode between the SYN and the V_{DD} pins: the ZVS signal is then made of high level pulses synchronized with the zero crossing. However, the coupler could be connected in low side mode with an external 10k pull-up resistor to V_{DD}: the ZVS is now inverted with low level pulses.

Figure 18: ZVS circuit operation with an opto-coupler

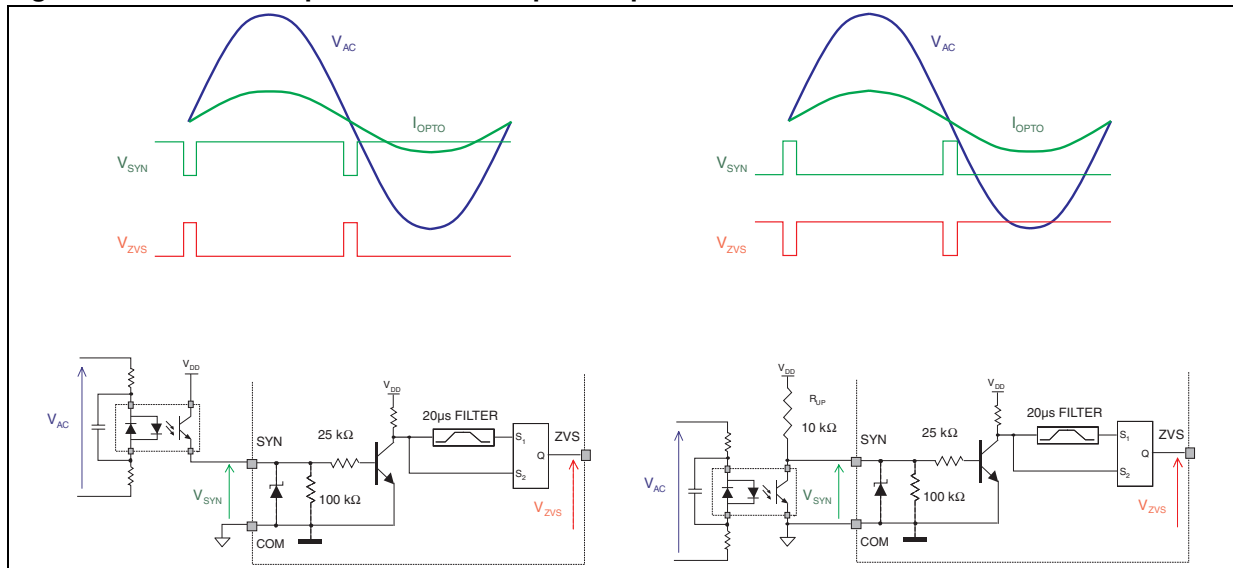
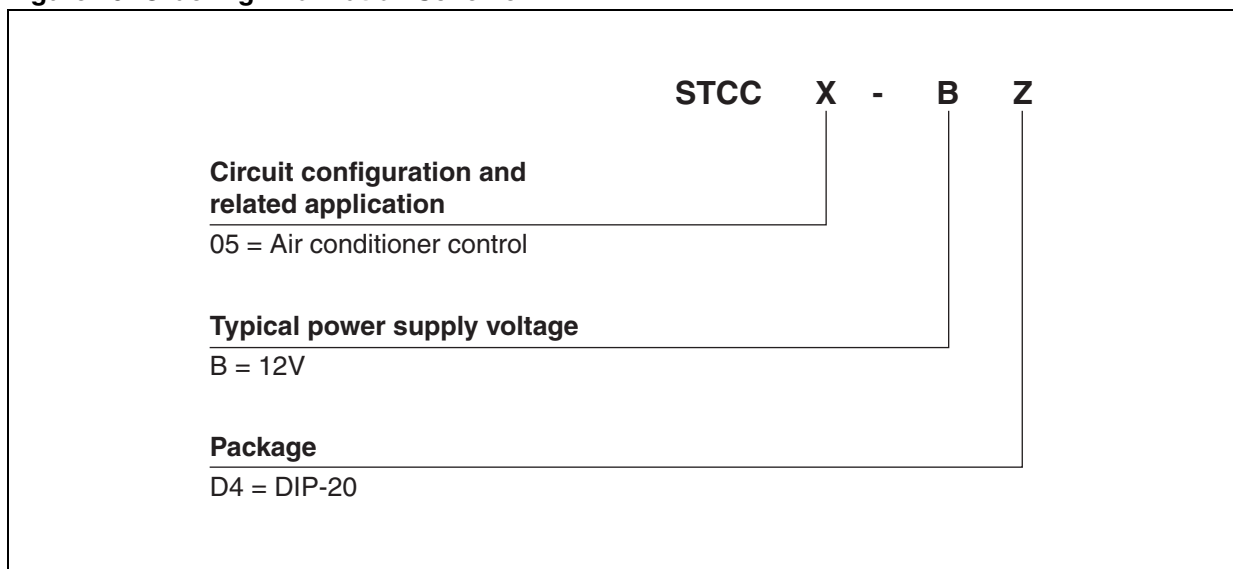

Figure 19: Ordering Information Scheme



STCC05-B

Figure 20: DIP-20 Package Mechanical Data

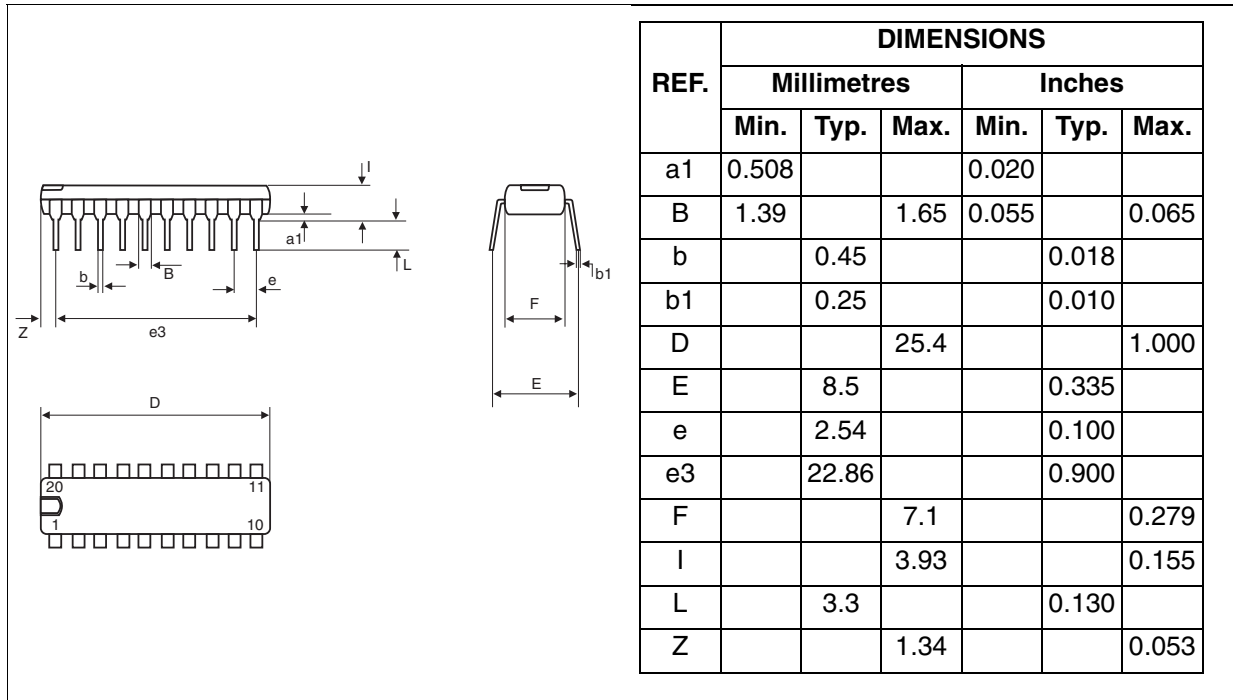

Table 6: Ordering Information

Part Number	Marking	Package	Weight	Base qty	Delivery mode
STCC05-BD4	STCC05-B	DIP-20	1.4 g	20	Tube

Table 7: Revision History

Date	Revision	Description of Changes
05-Oct-2004	1	First issue

Information furnished is believed to be accurate and reliable. However, STMicroelectronics assumes no responsibility for the consequences of use of such information nor for any infringement of patents or other rights of third parties which may result from its use. No license is granted by implication or otherwise under any patent or patent rights of STMicroelectronics. Specifications mentioned in this publication are subject to change without notice. This publication supersedes and replaces all information previously supplied. STMicroelectronics products are not authorized for use as critical components in life support devices or systems without express written approval of STMicroelectronics.

The ST logo is a registered trademark of STMicroelectronics.
All other names are the property of their respective owners

© 2004 STMicroelectronics - All rights reserved

STMicroelectronics group of companies

Australia - Belgium - Brazil - Canada - China - Czech Republic - Finland - France - Germany - Hong Kong - India - Israel - Italy - Japan -
Malaysia - Malta - Morocco - Singapore - Spain - Sweden - Switzerland - United Kingdom - United States of America
www.st.com