



Chipsmall Limited consists of a professional team with an average of over 10 year of expertise in the distribution of electronic components. Based in Hongkong, we have already established firm and mutual-benefit business relationships with customers from,Europe,America and south Asia,supplying obsolete and hard-to-find components to meet their specific needs.

With the principle of “Quality Parts,Customers Priority,Honest Operation,and Considerate Service”,our business mainly focus on the distribution of electronic components. Line cards we deal with include Microchip,ALPS,ROHM,Xilinx,Pulse,ON,Everlight and Freescale. Main products comprise IC,Modules,Potentiometer,IC Socket,Relay,Connector.Our parts cover such applications as commercial,industrial, and automotives areas.

We are looking forward to setting up business relationship with you and hope to provide you with the best service and solution. Let us make a better world for our industry!



## Contact us

Tel: +86-755-8981 8866 Fax: +86-755-8427 6832

Email & Skype: info@chipsmall.com Web: www.chipsmall.com

Address: A1208, Overseas Decoration Building, #122 Zhenhua RD., Futian, Shenzhen, China



# High power buck-boost white LED driver

Datasheet – production data

## Features

- Buck-boost DC-DC converter
- Drives one power LED up to 1 A in flash mode
- Drives one power LED up to 800 mA in continuous mode
- LED temperature protection
- Output current control
- 1.8 MHz (typ.) fixed frequency PWM
- Synchronous rectification
- High efficiency across the total input voltage range
- Operational modes:
  - Shutdown mode
  - High current mode: up to 1 A
  - Low current mode: from 20 mA
- Adjustable current in both modes
- Peak inductor limited to 2.3 A (typ.)
- LED disconnected from the battery in shutdown mode
- NTC LED temperature protection
- Overvoltage protection: 5.3 V
- Short-circuit protection
- Overtemperature protection
- ULVLO function
- 1  $\mu$ A max shutdown current
- QFN16 (4 x 4 x 1 mm) 16 leads

## Applications

- Camera flash for mobile phones
- Power supply for high power LEDs

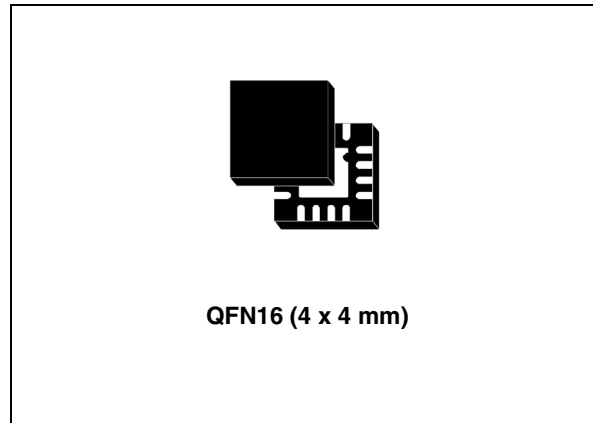

## Description

The STCF07 is a dedicated, size-optimized solution for driving a power LED. The device is a buck-boost converter which guarantees proper LED current control over all possible battery voltage and LED forward voltage conditions. The output current control ensures good current regulation over the forward voltage spread characteristics of high-brightness LEDs. The device includes various functions to protect the chip and the power LEDs. These include soft-start control as well as detection and protection of chip overtemperature and shorted LEDs. An optional external NTC is supported to protect the LEDs against overheating. It is possible to separately program the current intensity in HIGH and LOW mode using the SEL pin. The device is housed in a 16-lead QFN16 (4 x 4 mm) package with a height less than 1 mm.

**Table 1. Device summary**

Order code	Package	Packaging
STCF07PNR	QFN16 (4 x 4 mm)	Tape and reel

# Contents

<b>1</b>	<b>Block diagram</b> .....	<b>3</b>
<b>2</b>	<b>Pin configuration</b> .....	<b>4</b>
<b>3</b>	<b>Maximum ratings</b> .....	<b>5</b>
<b>4</b>	<b>Application information</b> .....	<b>6</b>
<b>5</b>	<b>Electrical characteristics</b> .....	<b>8</b>
<b>6</b>	<b>Introduction</b> .....	<b>10</b>
<b>7</b>	<b>Logic pin description</b> .....	<b>11</b>
	7.1 CSEL pin .....	11
	7.2 FAULT pin .....	11
	7.3 ENABLE pin .....	11
<b>8</b>	<b>Detailed description</b> .....	<b>12</b>
	8.1 Buck-boost converter .....	12
	8.2 High current mode .....	12
	8.3 Low current mode .....	12
	8.4 Shutdown mode .....	12
	8.5 Soft-start .....	12
	8.6 STCF07 protection features .....	13
	8.6.1 Peak current and short-circuit protection .....	13
	8.6.2 Overvoltage protection .....	13
	8.6.3 Thermal shutdown protection .....	13
	8.6.4 Sensing of LED temperature with the NTC resistor .....	13
	8.6.5 Undervoltage lockout function .....	14
<b>9</b>	<b>PCB design</b> .....	<b>15</b>
	9.1 PCB design rules .....	15
	9.2 PCB design of the demonstration board .....	16
	9.3 Schematic of the demonstration board .....	18

---

<b>10</b>	<b>Typical performance characteristics</b> .....	<b>19</b>
<b>11</b>	<b>External component selection</b> .....	<b>20</b>
	11.1 Input and output capacitor selection .....	20
	11.2 Inductor selection .....	20
	11.3 LED selection .....	20
	11.4 RHC selection .....	20
	11.5 RLC selection .....	21
	11.6 NTC and RX resistor selection .....	21
<b>12</b>	<b>Package mechanical data</b> .....	<b>22</b>
<b>13</b>	<b>Revision history</b> .....	<b>25</b>

# 1 Block diagram

Figure 1. STCF07 block diagram

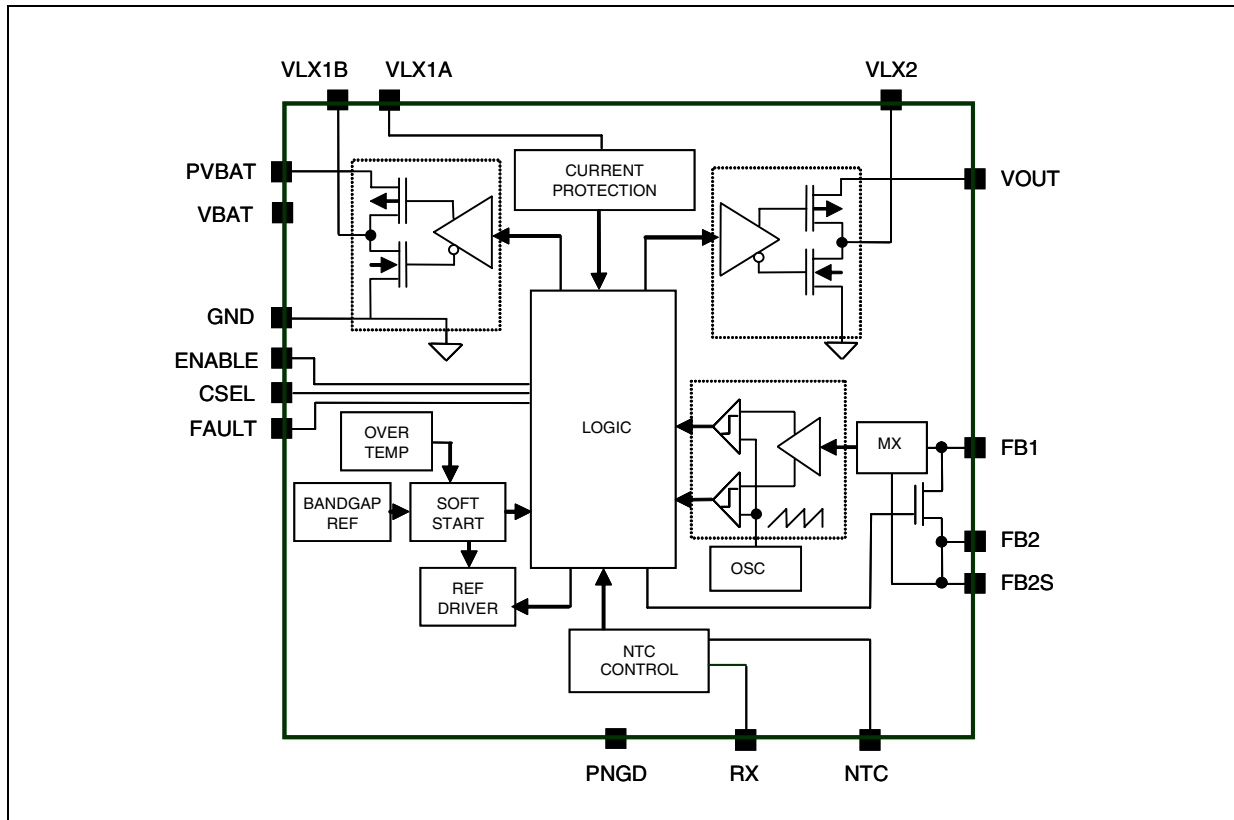



## 2 Pin configuration

Figure 2. STCF07 pin connections (top view)

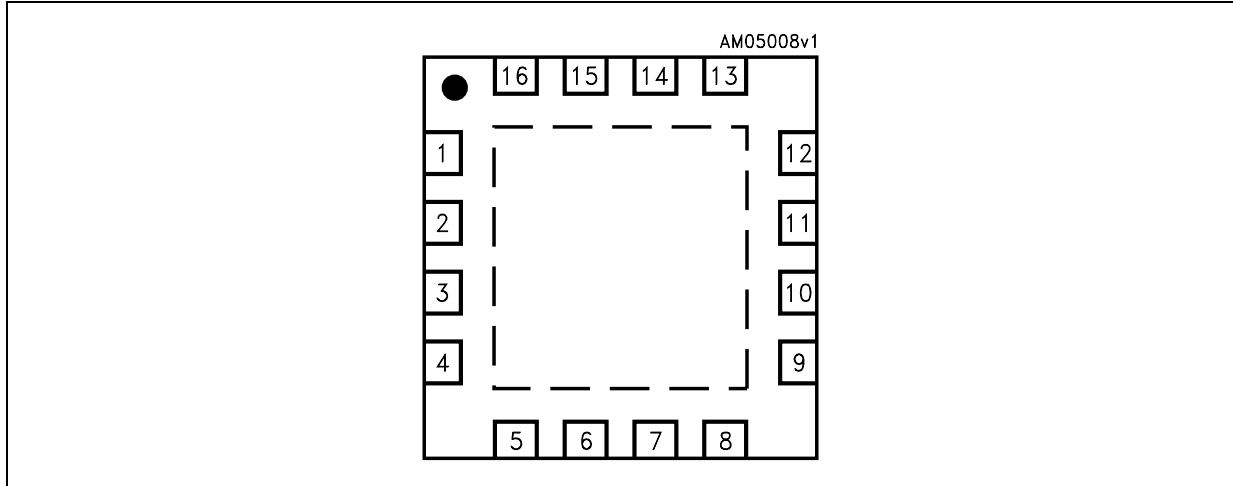

Table 2. STCF07 pin description

Pin n°	Symbol	Description
1	VLX2	Inductor VLX2 connection
8	RX	$R_X$ resistor connection
2	NTC	NTC resistor connection
3	VOUT	Output voltage
4	FB1	Feedback pin [ $I_{LED} \cdot (R_{HC} + R_{LC})$ ]
5	FB2	$R_{TR}$ bypass
6	FB2S	Feedback pin [ $I_{LED} \cdot R_{HC}$ ]
14	GND	Signal ground
13	CSEL	Current selection
7	EN	Enable
16	FAULT	Diagnostic
9	PVBAT	Power supply voltage
10	VBAT	Supply voltage
11	VLX1A	Inductor VLX1 connection
12	VLX1B	Inductor VLX1 connection
15	PGND	Power ground
Exposed pad	PGND	To be connected to the PCB ground plane for optimal electrical and thermal performance

### 3 Maximum ratings

**Table 3. Absolute maximum ratings**

Symbol	Parameter	Value	Unit
VBAT	Signal supply voltage	-0.3 to 6	V
PVBAT	Power supply voltage	-0.3 to 6	V
VLX1A, VLX1B	Inductor connection 1	-0.3 to $V_I+0.3$	V
VLX2	Inductor connection 2	-0.3 to $V_I+0.3$	V
VOUT	Output voltage	-0.3 to 6	V
FB1, FB2, FB2S	Feedback and sense voltage	-0.3 to 3	V
$R_X$	Connection for reference resistor	-0.3 to 3	V
CSEL	Current selection	-0.3 to $V_I+0.3$	V
EN	Enable	-0.3 to $V_I+0.3$	V
FAULT	Diagnostic	-0.3 to $V_I+0.3$	V
NTC	Connection for LED temperature sensing	-0.3 to 3	V
ESD	Human body model	$\pm 2$	kV
$P_{TOT}$	Continuous power dissipation (at $T_A = 70\text{ °C}$ )	800	mW
$T_{OP}$	Operating junction temperature range	-40 to 85	°C
$T_J$	Junction temperature	-40 to 150	°C
$T_{STG}$	Storage temperature range	-65 to 150	°C

*Note:* Absolute maximum ratings are those values beyond which damage to the device may occur. Functional operation under these condition is not implied.

**Table 4. Thermal data**

Symbol	Parameter	Value	Unit
$R_{thJA}^{(1)}$	Thermal resistance junction-ambient	31	°C/W

1. Junction-to-ambient thermal resistance in JEDEC still air chamber. Thermal test board JESD51-7 (leaded surface mount packages).

## 4 Application information

Figure 3. Application schematic diagram

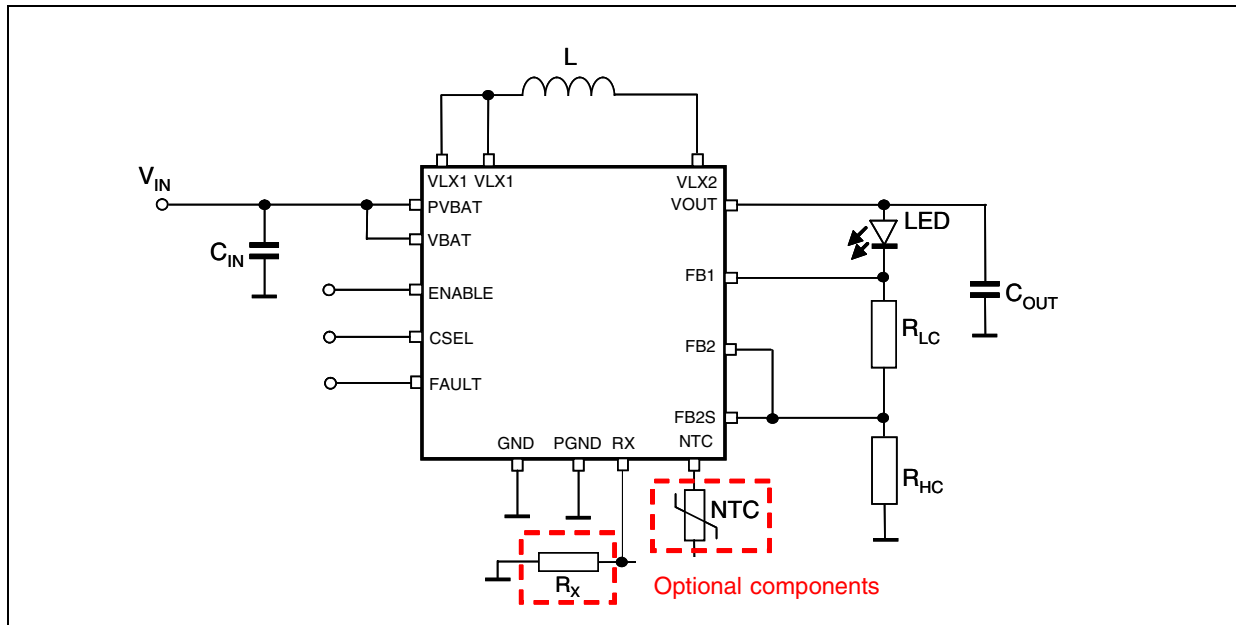

Note: Represents a typical application schematic for an output current of 800 mA (max) in continuous mode operation. For pulse/flash mode operation it is possible to increase the maximum output current up to 1 A. If the battery voltage is higher than 3.1 V, the chip is capable of delivering the maximum output current of up to 1 A in continuous mode.

Table 5. List of external components

Component	Manufacturer	Part number	Value	Size
R <sub>HC</sub>	Welwyn	LR1206-R20FI <sup>(1)</sup>	0.2 Ω	1206
	KOA	SR732BTTDR160F <sup>(2)</sup>	0.16 Ω	1206
R <sub>LC</sub>	Tyco Electronics	CRL1220T1R8J	1.8 Ω	0805
C <sub>IN</sub>	TDK	C1608X5R0J106MT	10 μF	0603
C <sub>OUT</sub>	TDK	C1608X5R0J475M	4.7 μF	0603
L	TDK	VLF4014ST-2R2M1R9 <sup>(1)</sup>	2.2 μH / 1.4 A	3.5x3.8x1.4 mm
		VLF5014S-2R2M2R3 <sup>(2)</sup>	2.2 μH / 2.3 A	4.6x4.8x1.4 mm
NTC	MURATA	NCP18WF104J03RB	100 kΩ	0805
R <sub>x</sub>	Tyco Electronics	1-1879132-9	15 kΩ	0402
LED	Luxeon	LXHL_PW09		

1. For 800 mA output current performance.
2. For 1000 mA output current performance.

Note: The above-listed external components refer to a typical application. Operation of the STCF07 is not limited to the use of these components.



## 5 Electrical characteristics

$T_A = 25\text{ }^\circ\text{C}$ ,  $V_I = 3.6\text{ V}$ ,  $2 \times C_I = 10\text{ }\mu\text{F}$ ,  $C_O = 1\text{ }\mu\text{F}$ ,  $L = 2.2\text{ }\mu\text{H}$ ,  $R_{HC} = 0.22\text{ }\Omega$ ,  $R_{LC} = 1.8\text{ }\Omega$ ,  $R_X = 15\text{ k}\Omega$

**Table 6. Electrical characteristics**

Symbol	Parameter	Test conditions	Min.	Typ.	Max.	Unit
$V_I$	Input voltage supply		2.7		5.5	V
UVLO	Undervoltage lockout	$V_I = 2.7\text{ V}$		2.2		V
$V_{PW\_ONRESET}$	Power ON reset threshold	$V_I$ rising		2.3		V
$I_O$	Output current - high current level	$CSEL = V_I$ ; $V_I = 2.7\text{ V to } 5.5\text{ V}$ ; $R_{HC} = 0.16\text{ }\Omega$ , $P_{OUT} = 3.4\text{ W}$			1000	mA
	Output current - high current level	$CSEL = V_I$ ; $V_I = 3.2\text{ V to } 5.5\text{ V}$ ; $R_{HC} = 0.16\text{ }\Omega$ , $P_{OUT} = 4\text{ W}$			1000	
	Output current - low current level	$CSEL = GND$ ; $V_I = 3.3\text{ V to } 5.5\text{ V}$ ; $R_{HC} + R_{LC} \sim 2\text{ }\Omega$	20			
$V_{OUT}$	Regulated voltage range		2.5		5.3	V
ILIM	Inductor peak current	$V_I = 2.7\text{ V}$ , $V_{OUT}$ shorted during operation		2.3		A
FB1	Feedback voltage	Low current ( $CSEL = 0\text{ V}$ )	152	160	168	mV
FB2	Feedback voltage	High current ( $CSEL = V_I$ )	152	160	168	mV
$R_{ON\_}$	FB1-FB2 ON resistance	High current ( $CSEL = V_I$ ) $I_O = 800\text{ mA}$		90		m $\Omega$
$I_Q$	Quiescent current in shutdown mode	$EN = GND$		1		$\mu\text{A}$
	Quiescent current in high current mode	$EN = V_I$ ; $CSEL = V_I$ ; $V_I = 3.3\text{ V to } 5.5\text{ V}$ ; $R_{HC} = 0.22\text{ }\Omega$		1.8		mA
$f_s$	Frequency	$V_I = 2.7\text{ V}$		1.8		MHz
n	Efficiency	$V_I = 3.2\text{ to } 4.2\text{ V}$ , $I_O = 800\text{ mA}$		85		%
OVP	Output overvoltage protection	$V_I = 5.5\text{ V}$ , no load	5.5			V
$OV_{HYST}$	Overvoltage hysteresis	$V_I = 5.5\text{ V}$ , no load		0.3		V
OTP	Overvoltage protection	$V_I = 5.5\text{ V}$		140		$^\circ\text{C}$
$OT_{HYST}$	Overvoltage hysteresis	$V_I = 5.5\text{ V}$		20		$^\circ\text{C}$
$V_{NTC}$	NTC voltage reference	$V_I = 2.7\text{ V to } 5.5\text{ V}$		1.8		V
$V_{RX}$	NTC voltage threshold	$I_{NTC} = 1\text{ mA Max}$		1.2		V
$NTC_{LEAK}$	RX-NTC switch OFF leakage	Shutdown mode, $V_{NTC} = 2\text{ V} - V_{RX} = GND$			1	$\mu\text{A}$
$V_{IL}$	Input logic signal level CSEL, EN	$V_I = 2.7\text{ V to } 5.5\text{ V}$	0		0.4	V
$V_{IH}$			1.4		3	

Table 6. Electrical characteristics (continued)

Symbol	Parameter	Test conditions	Min.	Typ.	Max.	Unit
FAULT	Low level voltage	$I_{\text{SINK}} = 5 \text{ mA}$		0.2	0.5	V
	Leakage current	$V_{\text{FAULT}} = 5 \text{ V}$		1		$\mu\text{A}$
$T_{\text{ON}}$	LED current rise time $I_{\text{LED}} = 0$ to $I_{\text{LED}} = \text{max}$				2	ms

## 6 Introduction

The STCF07 is a buck-boost converter designed to power and control the current of a power white LED. The device operates at a constant switching frequency of 1.8 MHz (typ). It provides an output voltage from 2.5 V up to 5.3 V, from a 2.7 V to 5.5 V supply voltage. This supply range allows the device to operate from a single-cell Lithium-Ion battery. The current is adjustable up to 1 A for an input voltage ranging from 2.7 V to 5.5 V and maximum output power up to 3.4 W. When the battery voltage is higher than 3.2 V, it is possible to increase the output power up to 4 W. The device uses an external NTC resistor to sense the temperature of the white LED. This function may not be needed in all applications, and in these cases the relevant external components can be omitted.

## 7 Logic pin description

### 7.1 CSEL pin

This input pin allows the setting of two different levels of current. When the voltage on this pin is low, the internal multiplexer switches the feedback to the FB1 pin, which is the dedicated feedback pin for low current operation. When the voltage on the CSEL pin is high, the internal multiplexer switches the feedback to the FB2s pin, and enables the shorting transistor connected between the FB1 and FB2 pins. The feedback voltage is sensed directly on the sensing  $R_{HC}$  by the connection of FB2s. This sensing pin is dedicated to high current operation.

### 7.2 FAULT pin

When the STCF07 is in ON mode (EN is high), the device is able to detect disconnection or failure of the LED. This information can be used by the system to signal that a problem has occurred in the LEDs.

### 7.3 ENABLE pin

This pin functions as an enable input. No internal pull-up or pull-down is provided.

## 8 Detailed description

### 8.1 Buck-boost converter

The regulation of the PWM controller is done by sensing the current of the LED through  $R_{LC}$  or  $R_{LC} + R_{HC}$ , depending on the CSEL voltage. Depending of the forward voltage of the flash LED, the device can automatically change between buck (step-down) and boost (step-up) mode:

- Boost region =  $V_{OUT} > V_{BAT}$ : this configuration is used in most cases, as the output voltage ( $V_{OUT} = V_F + I_{LED} \times R_{SENSE}$ ) is higher than  $V_{BAT}$
- Buck region =  $V_{OUT} < V_{BAT}$
- Buck / boost region =  $V_{OUT} \sim V_{IN}$

### 8.2 High current mode

ENABLE = CSEL =  $V_{BAT}$

The STCF07 operates continuously to supply maximum current to the LED up to 800 mA in high current mode. If high current mode is used in flash applications, then it is possible to increase the LED current up to 1066 mA.

The current can be adjusted with the  $R_{HC}$  resistor. The current is then programmed at:

$$I_{HC} = 160 \text{ mV} / R_{HC}$$

For a current programmed at 800 mA, the sensing resistor is equal to 0.20  $\Omega$ .

### 8.3 Low current mode

ENABLE =  $V_{BAT}$ , CSEL = 0

The STCF07 can continuously provide an adjustable current starting from 20 mA in low current mode. The current adjustment is done with resistor  $R_{LC}$ . The current is then programmed at:

$$I_{LC} = 160 \text{ mV} / (R_{HC} + R_{LC})$$

The NTC divider for measurement of the LED temperature is active.

### 8.4 Shutdown mode

ENABLE = 0

When the device is not used, it can be put in shutdown mode, which reduces the quiescent current to 1  $\mu\text{A}$ . The NTC protection in this mode is not active.

### 8.5 Soft-start

To avoid spikes on the battery during the startup sequence, a soft-start function has been implemented. The soft-start function is achieved by progressively increasing the feedback voltage reference. In worst-case conditions, the startup time, as defined below ( $I_{OUT} = I_{MAX}$ ), does not exceed 2 ms.

Figure 4. Startup: LED current rise time

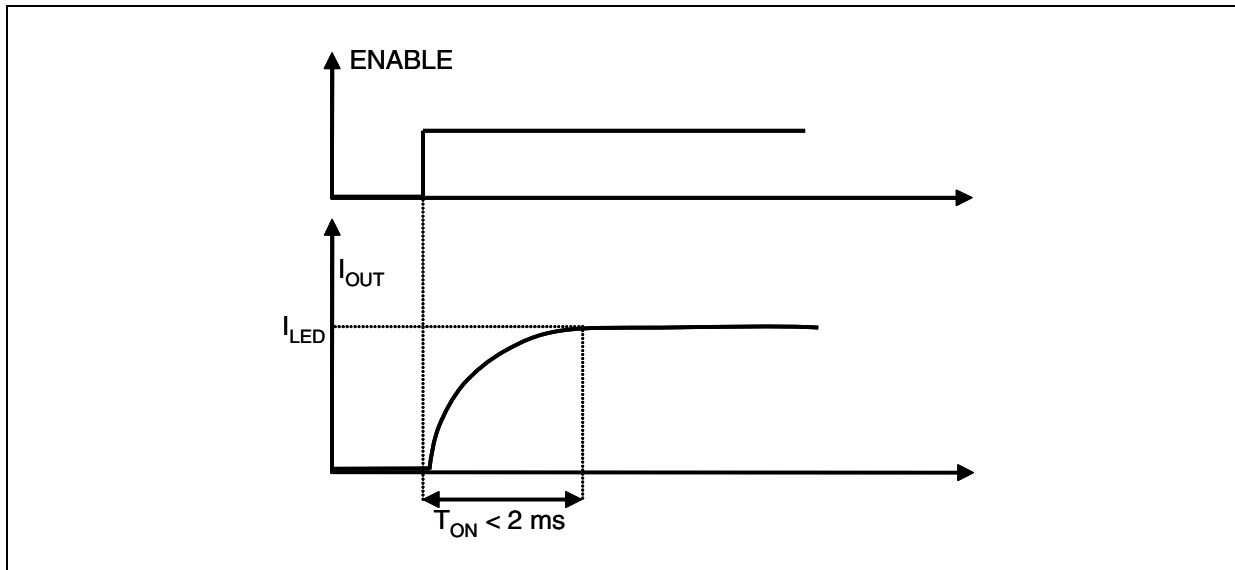

## 8.6 STCF07 protection features

### 8.6.1 Peak current and short-circuit protection

When the peak inductor current exceeds the maximum switch peak current limit of 2.3 A, the PWM controller turns off and is enabled at the next oscillation period.

### 8.6.2 Overvoltage protection

The device includes power failure protection, which stops the operation of the PWM controller when the voltage at the pin  $V_{OUT}$  exceeds the OVP threshold. When the voltage on pin  $V_{OUT}$  is reduced by  $OV_{HYST}$ , the operation of the controller recovers automatically.

### 8.6.3 Thermal shutdown protection

Internal thermal shutdown protection switches off the device when the junction temperature exceeds 140 °C (typ). The hysteresis comparator allows the PWM controller to restart automatically when the temperature is reduced to 120 °C.

### 8.6.4 Sensing of LED temperature with the NTC resistor

The device is capable of switching off the power circuit when a high temperature on the LED is detected. (see [Figure 5](#)).

If the sensing LED temperature feature is not used, NTC pin must be left floating and RX pin must be grounded.



Figure 5. Typical LED temperature sensing application with the NTC resistor

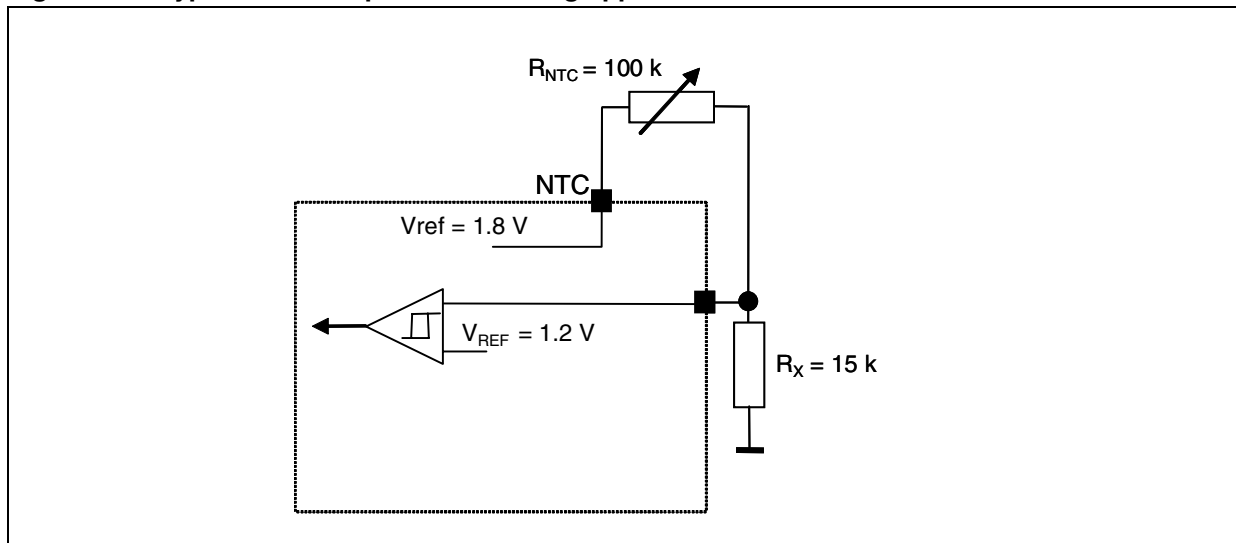

### 8.6.5 Undervoltage lockout function

If the device is ON and the battery voltage is as low as 2.2 V, the device goes into a FAULT state and the FAULT pin is put to LOW. To restart the device, the ENABLE pin must be reset LOW and HIGH.

## 9 PCB design

### 9.1 PCB design rules

The STCF07 is a powerful switched device, so the PCB must be designed following the rules for designing switched supplies. It is recommended to use at least a two-layer PCB. The power wiring must be as short and wide as possible, due to the high current. All external components should be placed close to the STCF07. High-energy switched loops should be as small as possible to reduce EMI. Most LEDs require cooling, which may be implemented by a defined copper area on the PCB. Use the reference guide for each LED to design the heatsink. Place the  $R_{FLASH}$  resistor as close as possible to pins 5 and 6. When a change of PCB layer is required, the number of vias must be sufficient. Place the NTC resistor as close as possible to the LED for good temperature sensing. Direct connection of GND and PGND is needed to achieve accurate output current values. The LED current should not flow through this track. Sensing of the voltage on the  $R_{FLASH}$  resistor must be done by connecting a wire directly from pin 6 to the  $R_{FLASH}$  resistor; no current flows through this track. Pins 5 and 6 must be connected to the pin of the  $R_{FLASH}$  resistor. The exposed pad must be connected to the PGND, with a track as wide as possible. It is recommended to place the copper plate, connected through the vias to the exposed pad, on the bottom layer to create a heatsink for the device. It is further recommended that the copper plate used be as large as possible to achieve optimal thermal performance.

## 9.2 PCB design of the demonstration board

Figure 6. Top layer

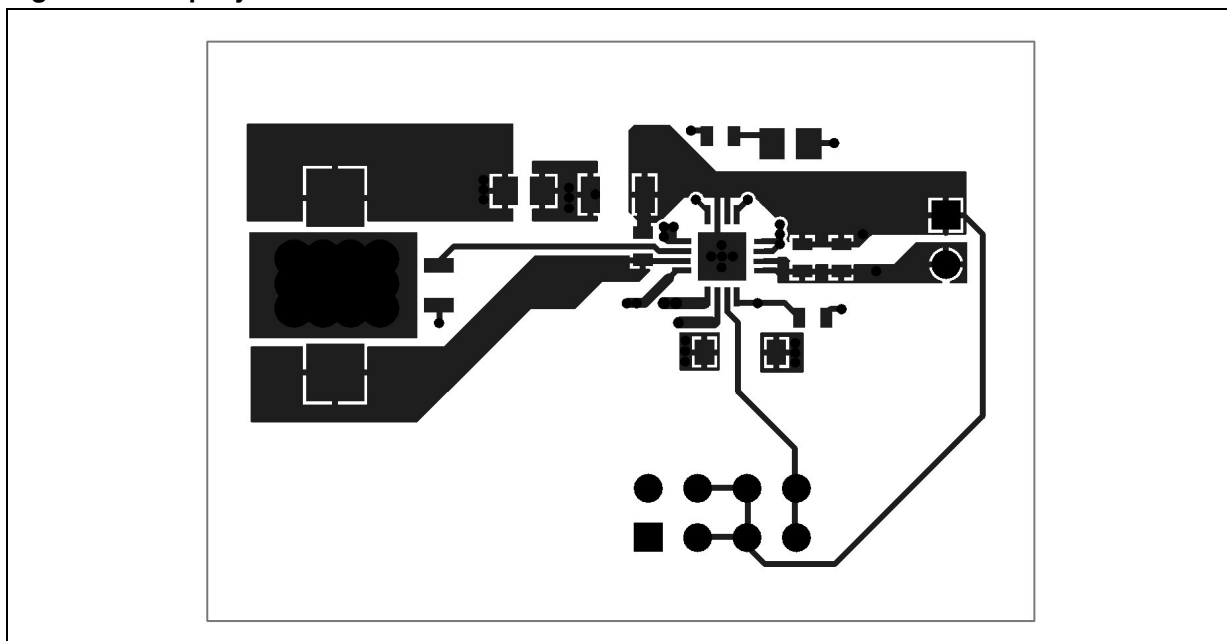

Figure 7. Bottom layer

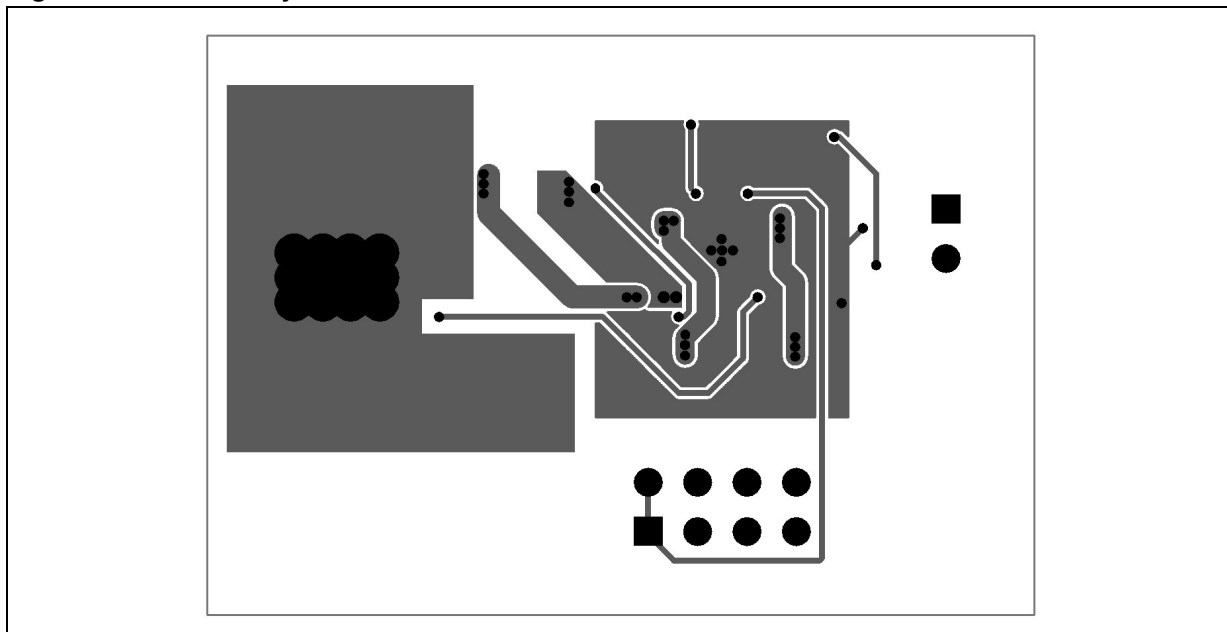
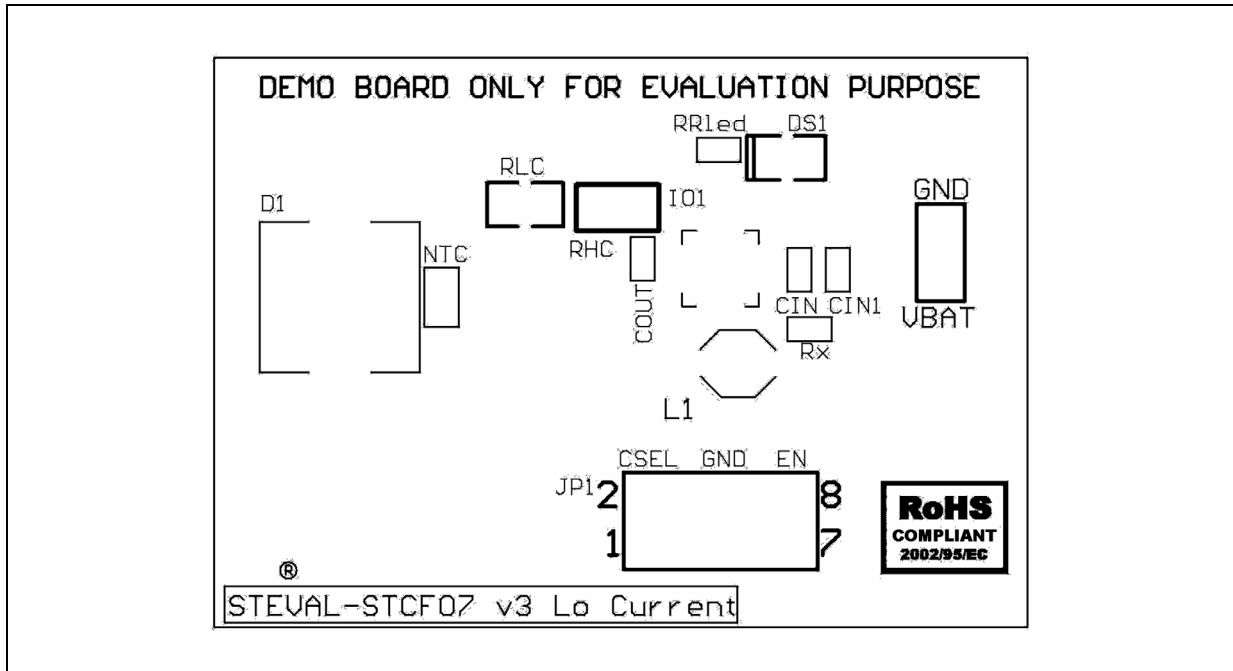
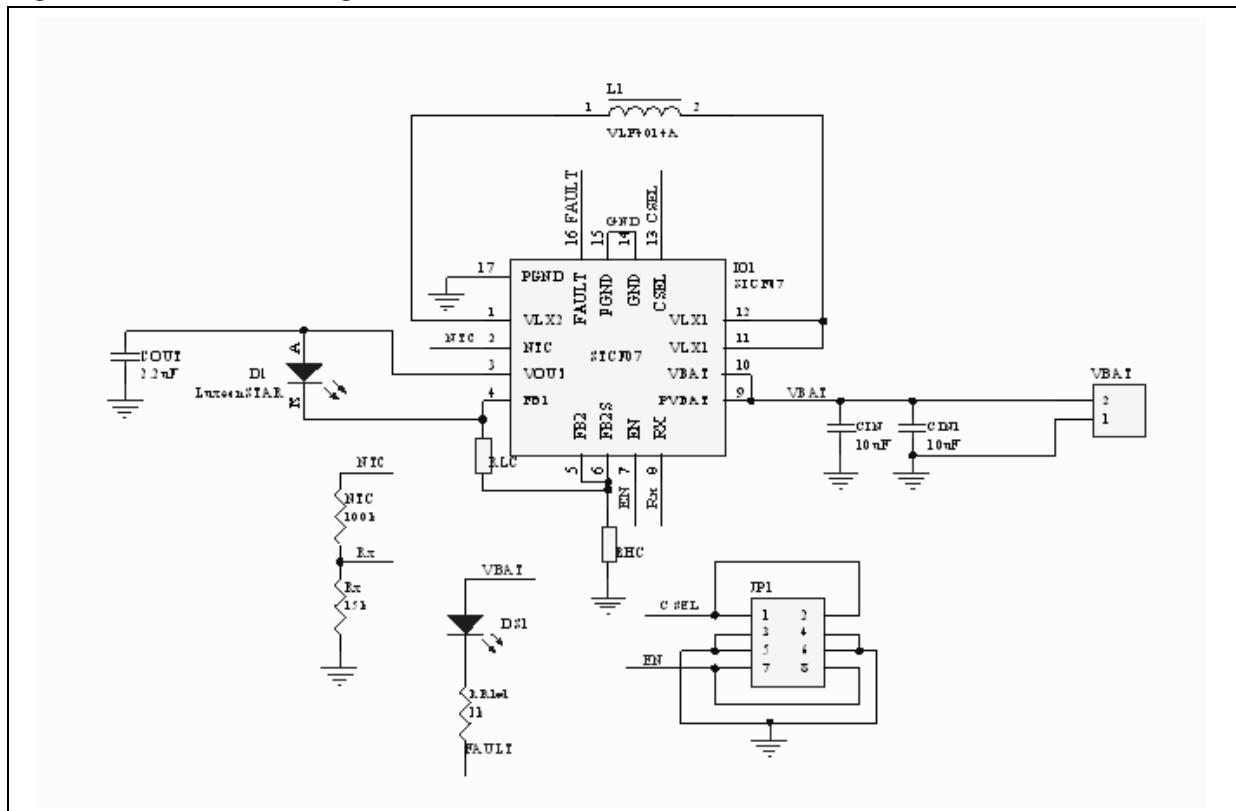

Figure 8. Top overlay



### 9.3 Schematic of the demonstration board

Figure 9. Schematic diagram of the STCF07 demonstration board



# 10 Typical performance characteristics

Figure 10.  $I_{OUT}$  80 mA vs.  $V_{IN}$

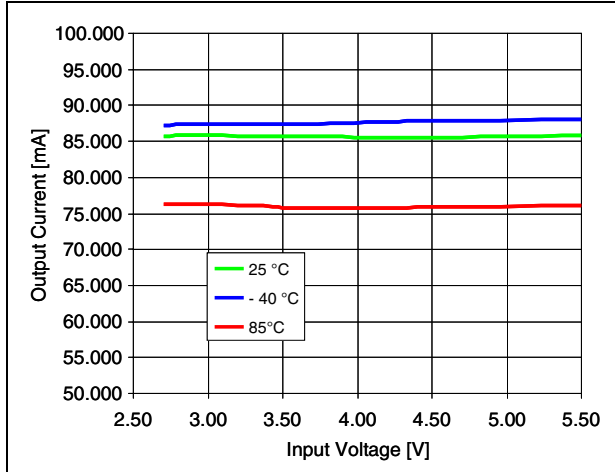

Figure 11.  $I_{OUT}$  800 mA vs.  $V_{IN}$

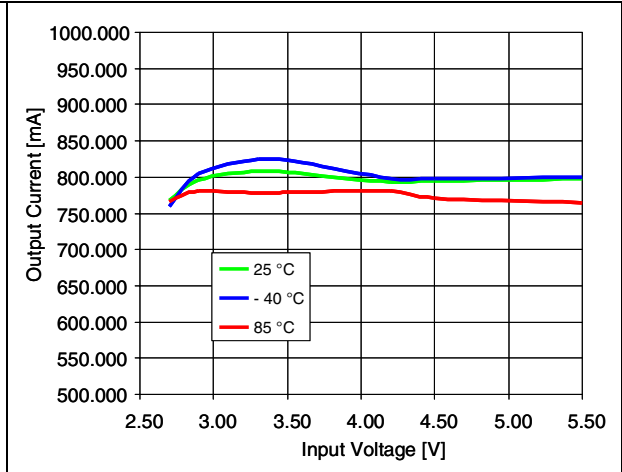

Figure 12. Efficiency vs.  $V_{IN}$

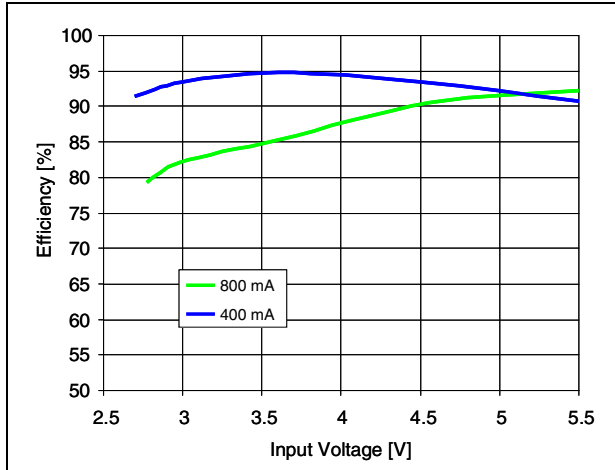

Figure 13. Efficiency vs.  $V_{IN}$ ,  $I_O = 400$  mA

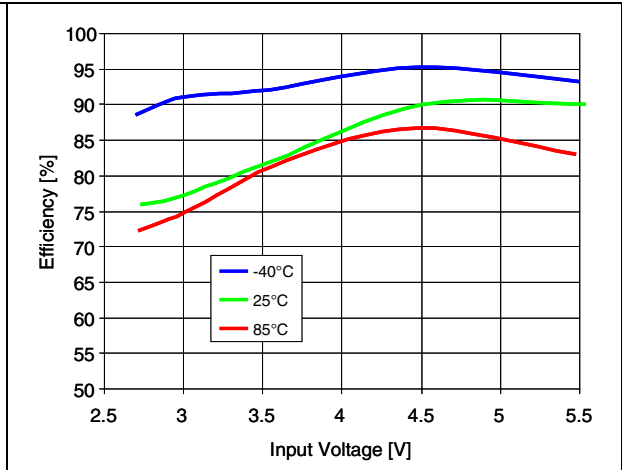
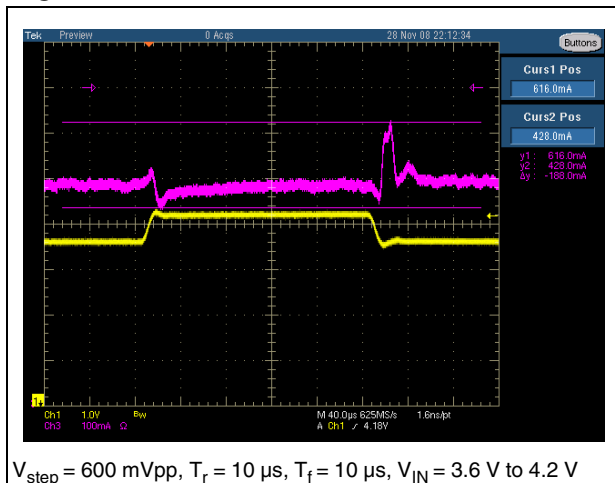

Figure 14. Line transient





## 11 External component selection

### 11.1 Input and output capacitor selection

For input and output capacitors it is recommended to use ceramic capacitors with low ESR. For good device stability when supplied by a low input voltage of 2.7 V at maximum ratings, it is recommended to use 10  $\mu\text{F}$  / 6.3 V as a minimum value for the input capacitor, and 4.7  $\mu\text{F}$  / 6.3 V as a minimum value for the output capacitor.

*Note:* See recommended components in [Table 5 on page 7](#).

### 11.2 Inductor selection

A thick, shielded inductor with low DC series wiring resistance is recommended for this application. For good efficiency, it is recommended to use an inductor with a series DC resistance of  $R_{\text{DCL}} < R_{\text{D}} / 10$ , where  $R_{\text{D}}$  is the dynamic resistance of the LED.

For nominal operation, the peak inductor current can be calculated using the formula:

$$I_{\text{PEAK}} = \left\{ (I_{\text{OUT}} / \eta) + [(V_{\text{OUT}} - V_{\text{IN}}) \times V_{\text{IN}}^2] / (2 \times L \times F \times V_{\text{OUT}}^2) \right\} \times V_{\text{OUT}} / V_{\text{IN}}$$

where:

$I_{\text{PEAK}}$  = peak inductor current

$I_{\text{OUT}}$  = current sourced at pin  $V_{\text{OUT}}$

$\eta$  = efficiency of the STCF07

$V_{\text{OUT}}$  = output voltage at pin  $V_{\text{OUT}}$

$V_{\text{IN}}$  = input voltage at pin  $V_{\text{IN}}$

$L$  = inductance value of the inductor

$F$  = switching frequency

*Note:* See recommended components in [Table 5 on page 7](#).

### 11.3 LED selection

All LEDs with forward voltages from 2.7 V to 5 V are suitable for use with STCF07 device. The LED forward voltage must include the voltage spread of this value. It is possible to set the LED current in the two different operating modes (high current mode and low current mode) through two external sensing resistors.

*Note:* See recommended components in [Table 5 on page 7](#).

### 11.4 $R_{\text{HC}}$ selection

The  $R_{\text{HC}}$  resistor value can be calculated using equations  $R_{\text{HC}} = 160 \text{ mV} / I_{\text{HC}}$  and  $P_{\text{RHC}} = R_{\text{HC}} \times I_{\text{HC}}^2$ , where  $P_{\text{RHC}}$  is the dissipated power on the  $R_{\text{HC}}$  resistor. It is recommended to use a 1206 package size thin metal film resistor with 1% or 5% maximum tolerance. The maximum high LED current for the STCF07 device is 800 mA with a battery voltage range 2.7 V to 5.5 V.

## 11.5 $R_{LC}$ selection

$R_{LC}$  resistor value can be calculated with the following equations:

$$R_{LC} = (160 \text{ mV} - I_{LC} * R_{HC}) / I_{LC} \text{ and } P_{RLC} = R_{LC} * I_{LC}^2$$

where  $P_{RLC}$  is the dissipated power on the  $R_{LC}$  resistor. It is recommended to use a thin metal film resistor with a 1% or 5% tolerance.

## 11.6 NTC and $R_X$ resistor selection

The NTC resistor for sensing LED temperature and the  $R_X$  resistor create a voltage divider. The output of this divider is compared with the 1.192 V internal voltage reference. When voltage on the output of the voltage divider is increased over the reference, the logic switches off the power circuit. Voltage divider is possible to supply from the NTC pin, where is output of the 1.8 V internal reference.

## 12 Package mechanical data

In order to meet environmental requirements, ST offers these devices in different grades of ECOPACK<sup>®</sup> packages, depending on their level of environmental compliance. ECOPACK<sup>®</sup> specifications, grade definitions and product status are available at: [www.st.com](http://www.st.com). ECOPACK<sup>®</sup> is an ST trademark.

**QFN16 (4 x 4) mechanical data**

Dim.	mm.			inch.		
	Min.	Typ.	Max.	Min.	Typ.	Max.
A	0.80	0.90	1.00	31.5	35.4	39.4
A1		0.02	0.05		0.8	2.0
A2		0.65	1.00		25.6	39.4
A3		0.20			7.9	
b	0.18	0.25	0.30	7.1	9.8	11.8
D	3.85	4.00	4.15	151.6	157.5	163.4
D2	2.10		2.60	82.7		102.4
E	3.85	4.00	4.15	151.6	157.5	163.4
E2	2.10		2.60	82.7		102.4
e		0.50			19.7	
L	0.30	0.40	0.50	11.8	15.7	19.7
ddd			0.08			3.1

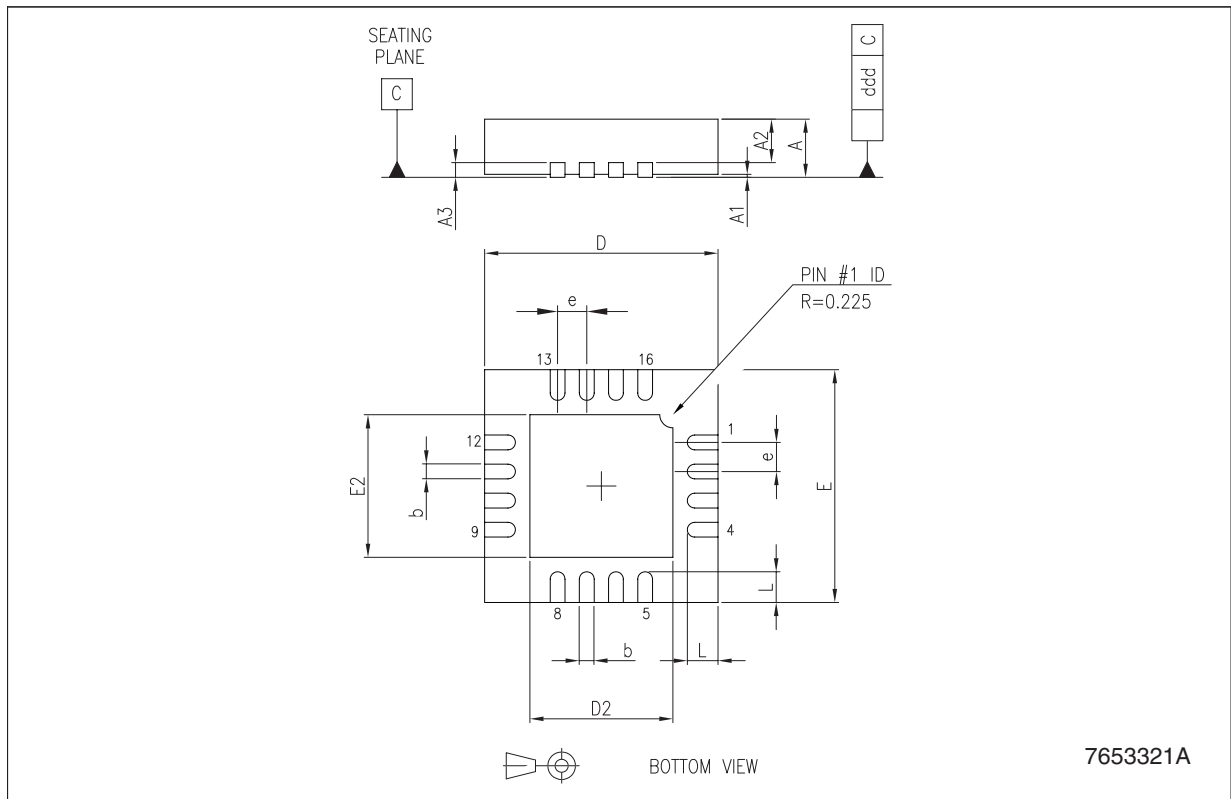

7653321A

**Tape & reel QFNxx/DFNxx (4x4) mechanical data**

Dim.	mm.			inch.		
	Min.	Typ.	Max.	Min.	Typ.	Max.
A			330			12.992
C	12.8		13.2	0.504		0.519
D	20.2			0.795		
N	99		101	3.898		3.976
T			14.4			0.567
Ao		4.35			0.171	
Bo		4.35			0.171	
Ko		1.1			0.043	
Po		4			0.157	
P		8			0.315	

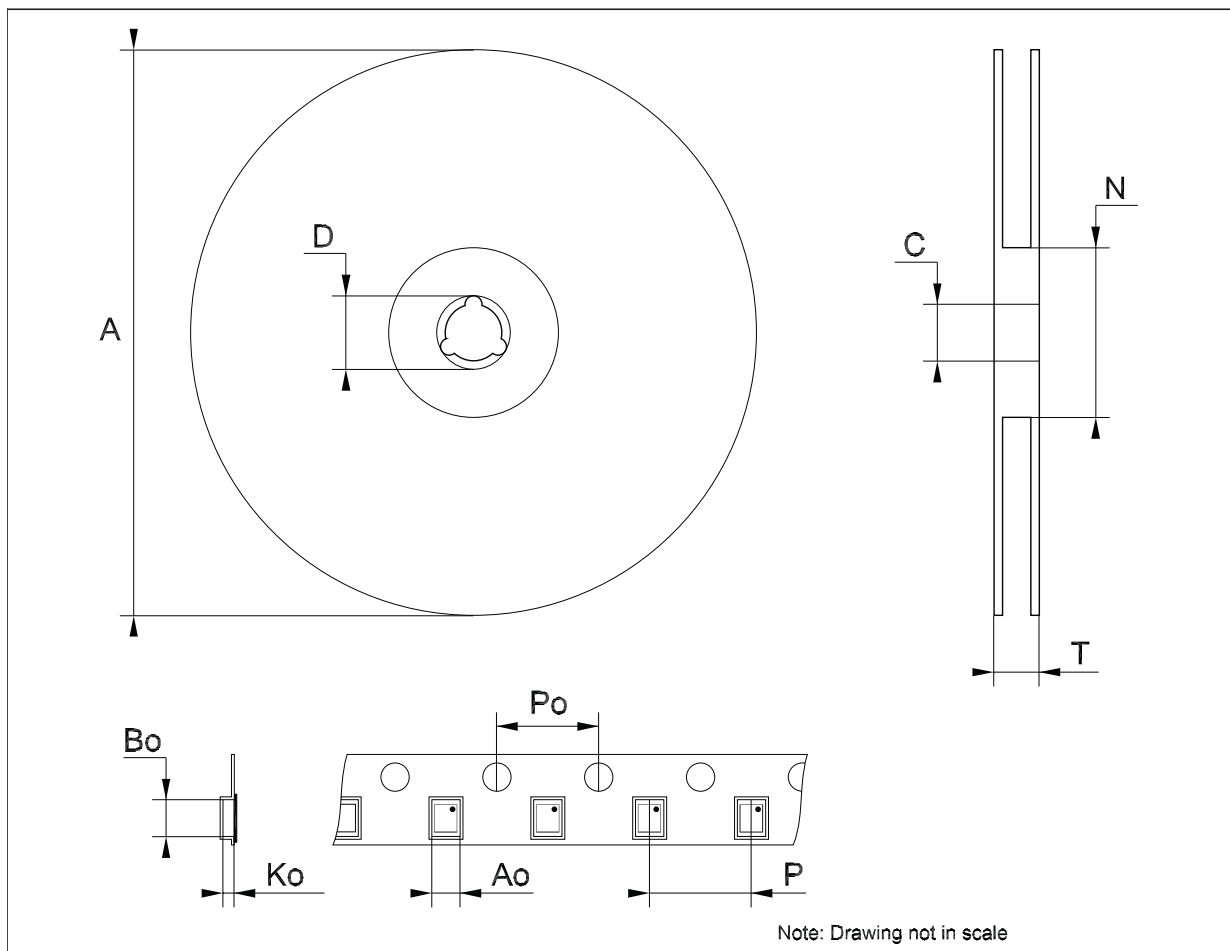

## 13 Revision history

**Table 7. Document revision history**

Date	Revision	Changes
18-Nov-2009	1	First release.
12-Apr-2011	2	Updated <a href="#">Table 5 on page 7</a> .
10-Sep-2012	3	Modified: <a href="#">Chapter 8.6.4 on page 13</a> .