



Chipsmall Limited consists of a professional team with an average of over 10 year of expertise in the distribution of electronic components. Based in Hongkong, we have already established firm and mutual-benefit business relationships with customers from,Europe,America and south Asia,supplying obsolete and hard-to-find components to meet their specific needs.

With the principle of “Quality Parts,Customers Priority,Honest Operation,and Considerate Service”,our business mainly focus on the distribution of electronic components. Line cards we deal with include Microchip,ALPS,ROHM,Xilinx,Pulse,ON,Everlight and Freescale. Main products comprise IC,Modules,Potentiometer,IC Socket,Relay,Connector.Our parts cover such applications as commercial,industrial, and automotives areas.

We are looking forward to setting up business relationship with you and hope to provide you with the best service and solution. Let us make a better world for our industry!



Contact us

Tel: +86-755-8981 8866 Fax: +86-755-8427 6832

Email & Skype: info@chipsmall.com Web: www.chipsmall.com

Address: A1208, Overseas Decoration Building, #122 Zhenhua RD., Futian, Shenzhen, China



N-channel 950 V, 2 Ω typ., 3.5 A MDmesh™ K5
Power MOSFETs in DPAK, TO-220FP, TO-220 and IPAK

Datasheet - production data

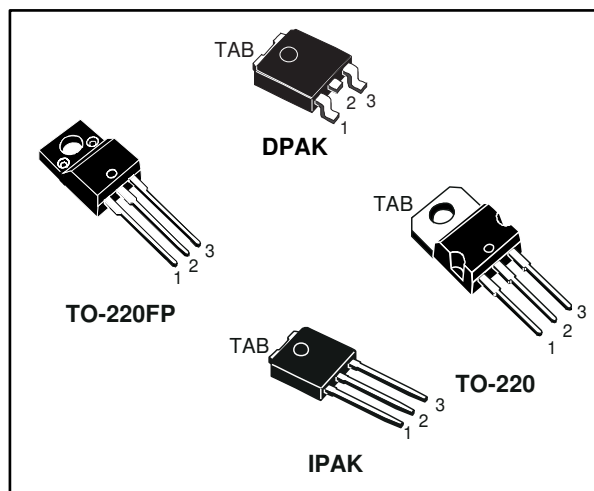
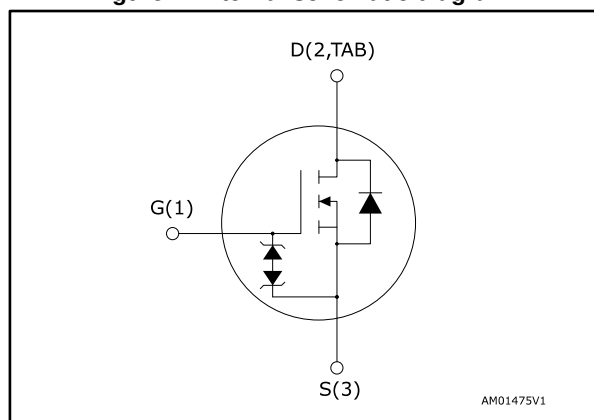

Figure 1: Internal schematic diagram



Features

Order code	V _{DS}	R _{DS(on)} max.	I _D	P _{tot}
STD5N95K5	950 V	2.5 Ω	3.5 A	70 W
STF5N95K5				25 W
STP5N95K5				70 W
STU5N95K5				70 W

- Industry's lowest R_{DS(on)} x area
- Industry's best FoM (figure of merit)
- Ultra-low gate charge
- 100% avalanche tested
- Zener-protected

Applications

- Switching applications

Description

These very high voltage N-channel Power MOSFETs are designed using MDmesh™ K5 technology based on an innovative proprietary vertical structure. The result is a dramatic reduction in on-resistance and ultra-low gate charge for applications requiring superior power density and high efficiency.

Table 1: Device summary

Order code	Marking	Package	Packing
STD5N95K5	5N95K5	DPAK	Tape and reel
STF5N95K5		TO-220FP	Tube
STP5N95K5		TO-220	
STU5N95K5		IPAK	

Contents

1	Electrical ratings	3
2	Electrical characteristics	4
	2.1 Electrical characteristics (curves)	6
3	Test circuits	9
4	Package information	10
	4.1 DPAK (TO-252) type A2 package information.....	11
	4.2 DPAK (TO-252) type C2 package information	14
	4.3 DPAK (TO-252) packing information.....	17
	4.4 TO-220FP package information	19
	4.5 TO-220 type A package information.....	21
	4.6 IPAK (TO-251) type A package information	23
5	Revision history	25

1 Electrical ratings

Table 2: Absolute maximum ratings

Symbol	Parameter	Value		Unit
		DPAK, TO-220, IPAK	TO-220FP	
V _{GS}	Gate-source voltage	±30		V
I _D	Drain current (continuous) at T _C = 25 °C	3.5	3.5 ⁽¹⁾	A
I _D	Drain current (continuous) at T _C = 100 °C	2.2	2.2 ⁽¹⁾	A
I _{DM} ⁽²⁾	Drain current pulsed	14		A
P _{TOT}	Total dissipation at T _C = 25 °C	70	25	W
dv/dt ⁽³⁾	Peak diode recovery voltage slope	4.5		V/ns
dv/dt ⁽⁴⁾	MOSFET dv/dt ruggedness	50		V/ns
V _{ISO}	Insulation withstand voltage (RMS) from all three leads to external heat sink (t=1 s; T _C =25 °C)		2500	V
T _j	Operating junction temperature range	-55 to 150		°C
T _{stg}	Storage temperature range			

Notes:

- ⁽¹⁾Limited by maximum junction temperature.
- ⁽²⁾Pulse width limited by safe operating area.
- ⁽³⁾I_{SD} ≤ 3.5 A, di/dt ≤ 100 A/μs, V_{DS} (peak) ≤ V_{(BR)DSS}
- ⁽⁴⁾V_{DS} ≤ 640 V

Table 3: Thermal data

Symbol	Parameter	Value				Unit
		DPAK	TO-220FP	TO-220	IPAK	
R _{thj-case}	Thermal resistance junction-case	1.47	5	1.47		°C/W
R _{thj-amb}	Thermal resistance junction-ambient		62.5		100	°C/W
R _{thj-pcb} ⁽¹⁾	Thermal resistance junction-pcb	50				°C/W

Notes:

- ⁽¹⁾When mounted on 1 inch² FR-4, 2 Oz copper board

Table 4: Avalanche characteristics

Symbol	Parameter	Value	Unit
I _{AR}	Avalanche current, repetitive or not repetitive (pulse width limited by T _{jmax})	1	A
E _{AS}	Single pulse avalanche energy (starting T _j = 25 °C, I _D = I _{AR} , V _{DD} = 50 V)	70	mJ

2 Electrical characteristics

$T_C = 25\text{ }^\circ\text{C}$ unless otherwise specified

Table 5: On/off-state

Symbol	Parameter	Test conditions	Min.	Typ.	Max.	Unit
$V_{(BR)DSS}$	Drain-source breakdown voltage	$V_{GS} = 0\text{ V}$, $I_D = 1\text{ mA}$	950			V
I_{DSS}	Zero gate voltage drain current	$V_{DS} = 950\text{ V}$, $V_{GS} = 0\text{ V}$			1	μA
		$V_{DS} = 950\text{ V}$, $V_{GS} = 0\text{ V}$ $T_C = 125\text{ }^\circ\text{C}^{(1)}$			50	μA
I_{GSS}	Gate body leakage current	$V_{GS} = \pm 20\text{ V}$, $V_{DS} = 0\text{ V}$			± 10	μA
$V_{GS(th)}$	Gate threshold voltage	$V_{DS} = V_{GS}$, $I_D = 100\text{ }\mu\text{A}$	3	4	5	V
$R_{DS(on)}$	Static drain-source on-resistance	$V_{GS} = 10\text{ V}$, $I_D = 1.5\text{ A}$		2	2.5	Ω

Notes:

⁽¹⁾Defined by design, not subject to production test.

Table 6: Dynamic

Symbol	Parameter	Test conditions	Min.	Typ.	Max.	Unit
C_{iss}	Input capacitance	$V_{DS} = 100\text{ V}$, $f = 1\text{ MHz}$, $V_{GS} = 0\text{ V}$	-	220	-	pF
C_{oss}	Output capacitance		-	17	-	pF
C_{rss}	Reverse transfer capacitance		-	1	-	pF
$C_{o(tr)}^{(1)}$	Equivalent capacitance time related	$V_{GS} = 0\text{ V}$, $V_{DS} = 0\text{ to }760\text{ V}$	-	30	-	pF
$C_{o(er)}^{(2)}$	Equivalent capacitance energy related		-	11	-	pF
R_g	Intrinsic gate resistance	$f = 1\text{ MHz}$ open drain	-	17	-	Ω
Q_g	Total gate charge	$V_{DD} = 760\text{ V}$, $I_D = 3.5\text{ A}$ $V_{GS} = 10\text{ V}$ (see Figure 19: "Test circuit for gate charge behavior")	-	12.5	-	nC
Q_{gs}	Gate-source charge		-	2	-	nC
Q_{gd}	Gate-drain charge		-	10	-	nC

Notes:

⁽¹⁾ $C_{o(tr)}$ is a constant capacitance value that gives the same charging time as C_{oss} while V_{DS} is rising from 0 to 80% V_{DSS} .

⁽²⁾ $C_{o(er)}$ is a constant capacitance value that gives the same stored energy as C_{oss} while V_{DS} is rising from 0 to 80% V_{DSS} .

Table 7: Switching times

Symbol	Parameter	Test conditions	Min.	Typ.	Max.	Unit
$t_{d(on)}$	Turn-on delay time	$V_{DD} = 475 \text{ V}$, $I_D = 1.75 \text{ A}$, $R_G = 4.7 \Omega$ $V_{GS} = 10 \text{ V}$ (see Figure 18: "Test circuit for resistive load switching times" and Figure 23: "Switching time waveform")	-	12	-	ns
t_r	Rise time		-	16	-	ns
$t_{d(off)}$	Turn-off delay time		-	32	-	ns
t_f	Fall time		-	25	-	ns

Table 8: Source-drain diode

Symbol	Parameter	Test conditions	Min.	Typ.	Max.	Unit
I_{SD}	Source-drain current		-		3.5	A
I_{SDM}	Source-drain current (pulsed)		-		14	A
$V_{SD}^{(1)}$	Forward on voltage	$I_{SD} = 3.5 \text{ A}$, $V_{GS} = 0 \text{ V}$	-		1.5	V
t_{rr}	Reverse recovery time	$I_{SD} = 3.5 \text{ A}$, $di/dt = 100 \text{ A}/\mu\text{s}$, $V_{DD} = 60 \text{ V}$ (see Figure 20: "Test circuit for inductive load switching and diode recovery times")	-	330		ns
Q_{rr}	Reverse recovery charge		-	2.2		μC
I_{RRM}	Reverse recovery current		-	13		A
t_{rr}	Reverse recovery time		$I_{SD} = 3.5 \text{ A}$, $di/dt = 100 \text{ A}/\mu\text{s}$, $V_{DD} = 60 \text{ V}$, $T_j = 150 \text{ }^\circ\text{C}$ (see Figure 20: "Test circuit for inductive load switching and diode recovery times")	-	525	
Q_{rr}	Reverse recovery charge	-		3.2		μC
I_{RRM}	Reverse recovery current	-		12		A

Notes:

⁽¹⁾Pulsed: pulse duration = 300 μs , duty cycle 1.5%

Table 9: Gate-source Zener diode

Symbol	Parameter	Test conditions	Min	Typ.	Max	Unit
$V_{(BR)GSO}$	Gate-source breakdown voltage	$I_{GS} = \pm 1 \text{ mA}$, $I_D = 0 \text{ A}$	30	-	-	V

The built-in back-to-back Zener diodes are specifically designed to enhance the ESD performance of the device. The Zener voltage facilitates efficient and cost-effective device integrity protection, thus eliminating the need for additional external componentry.

2.1 Electrical characteristics (curves)

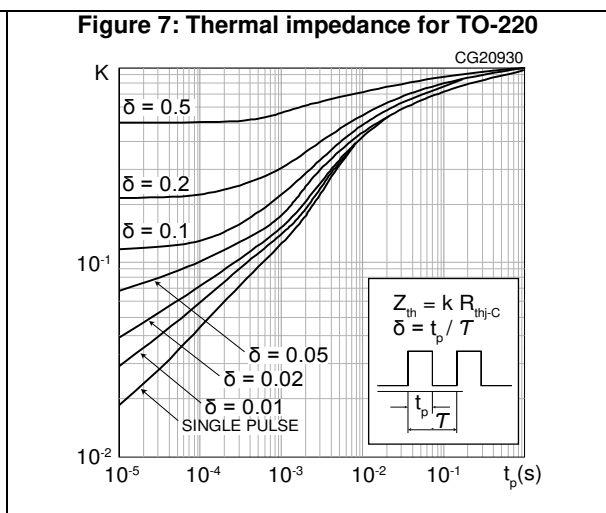
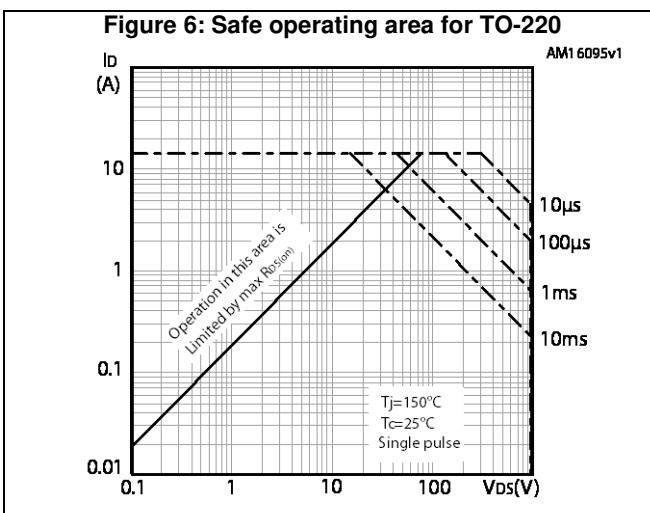
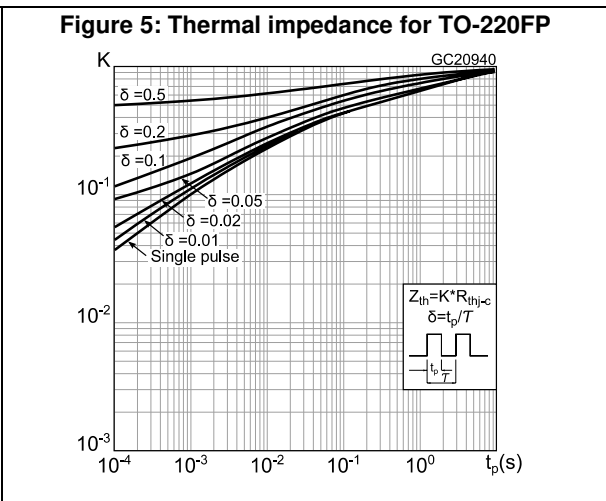
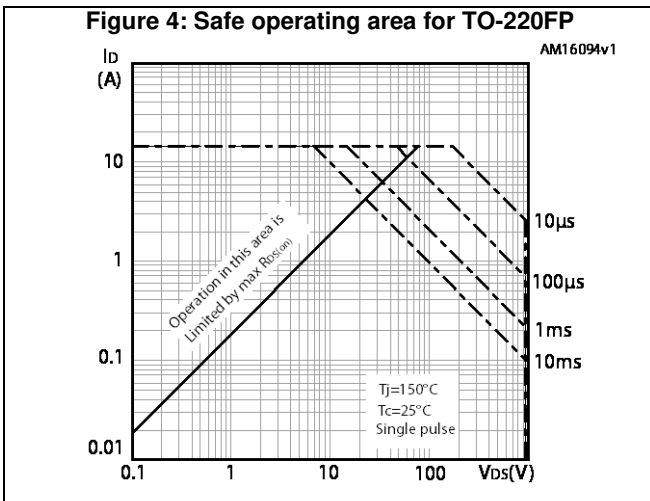
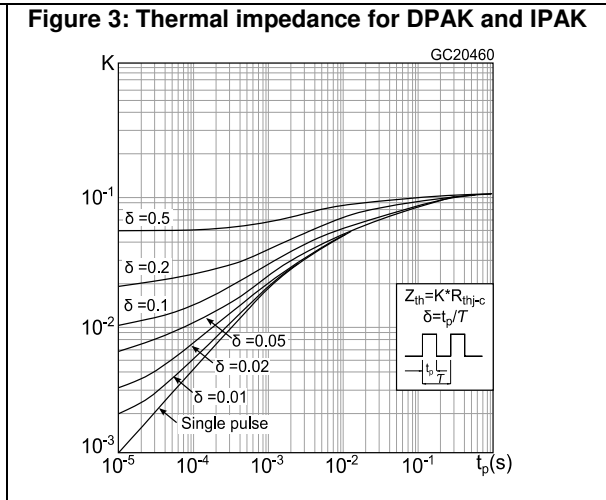
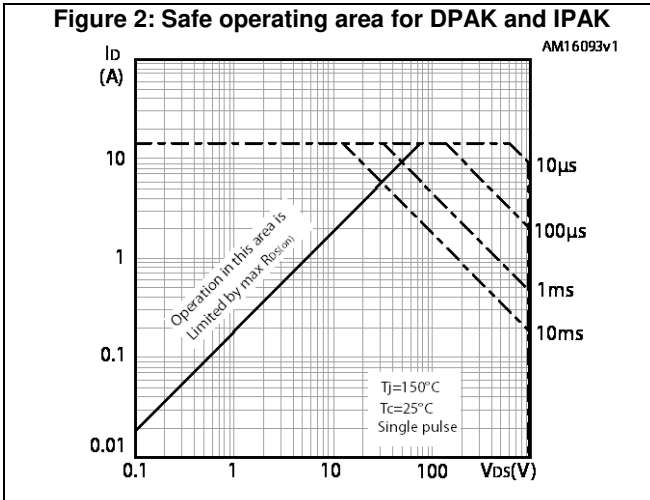

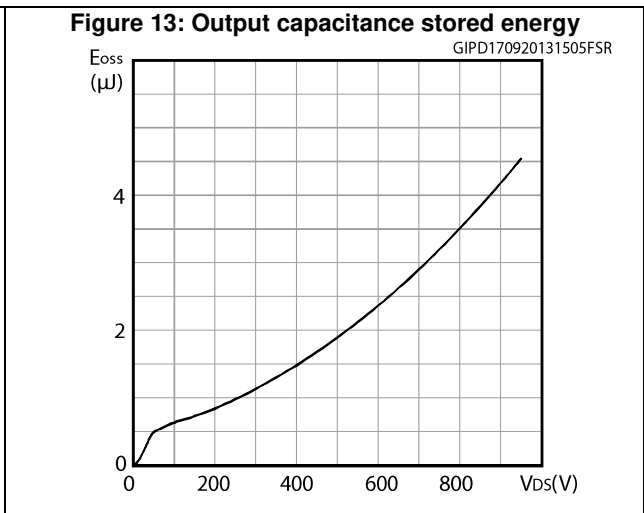
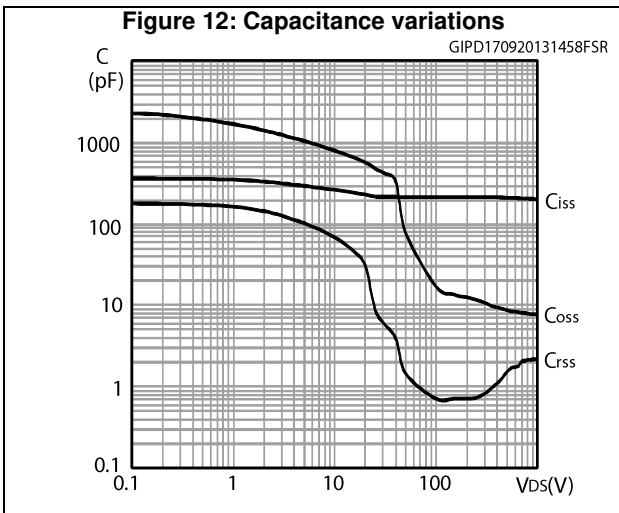
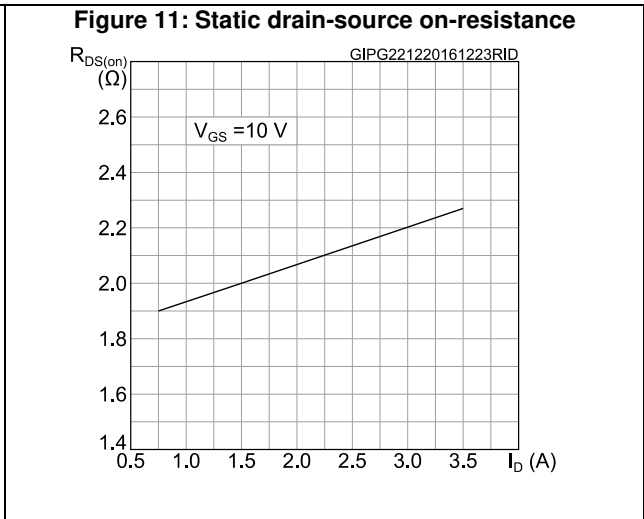
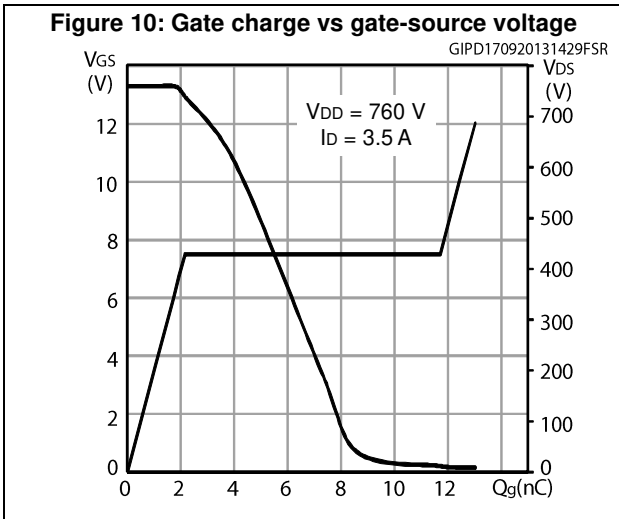
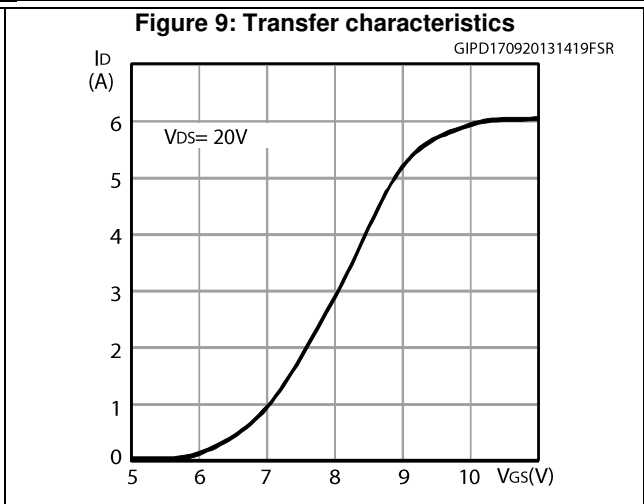
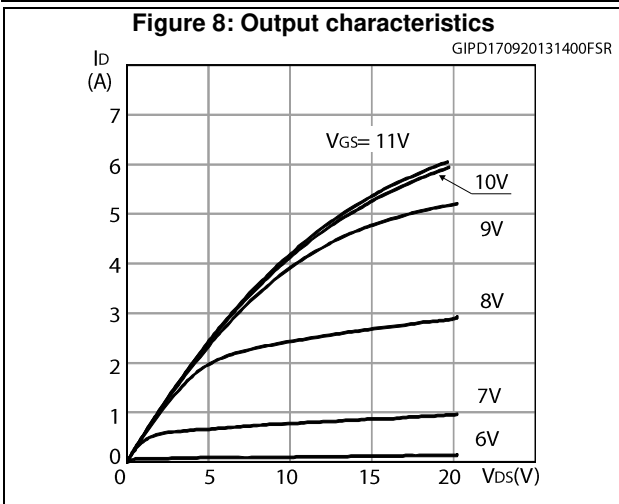

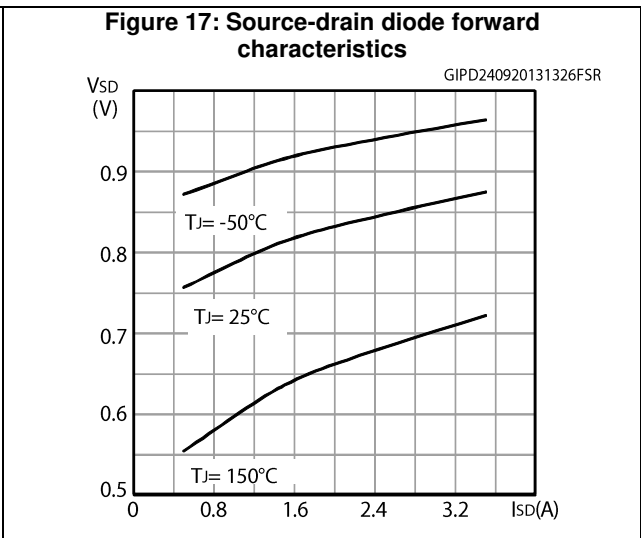
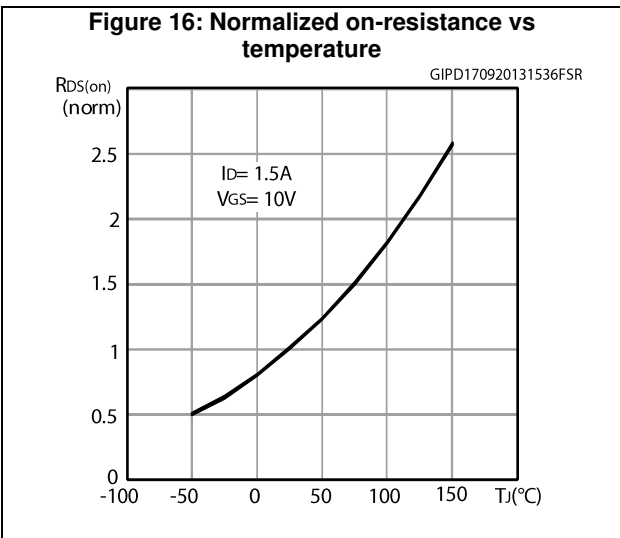
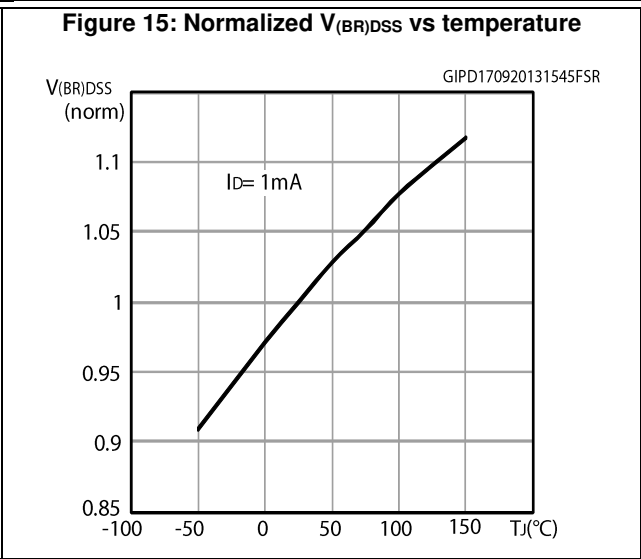
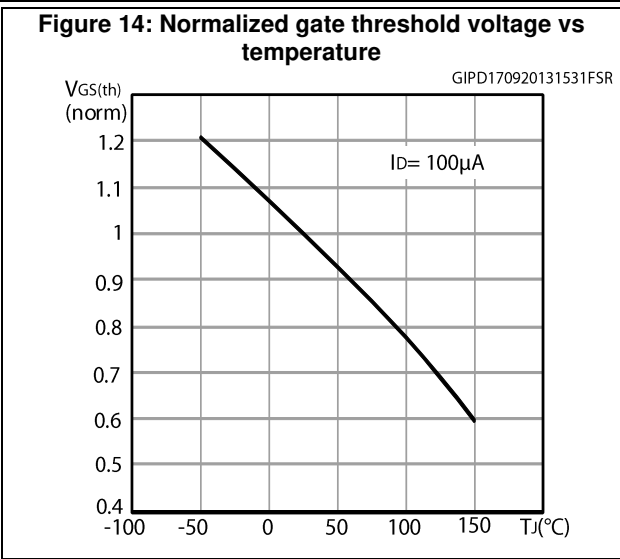

3 Test circuits

Figure 18: Test circuit for resistive load switching times

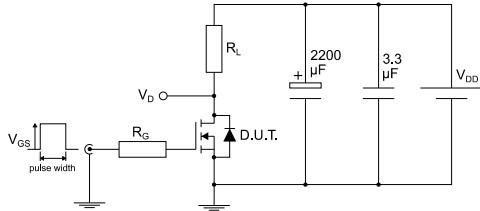

AM01468v1

Figure 19: Test circuit for gate charge behavior

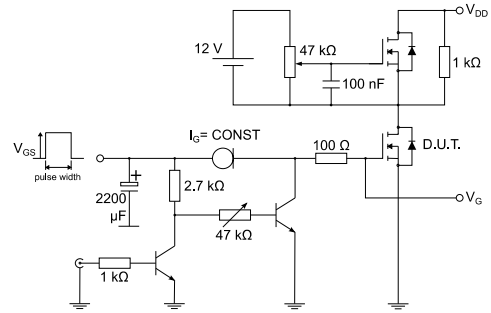

AM01469v1

Figure 20: Test circuit for inductive load switching and diode recovery times

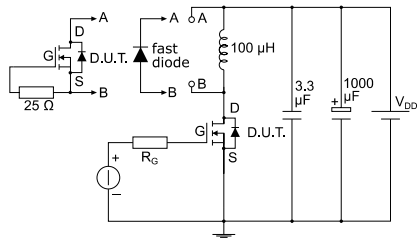

AM01470v1

Figure 21: Unclamped inductive load test circuit

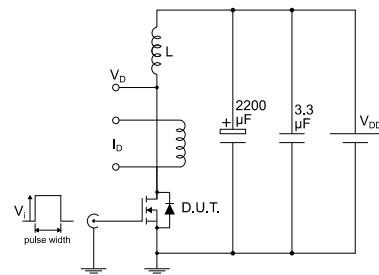

AM01471v1

Figure 22: Unclamped inductive waveform

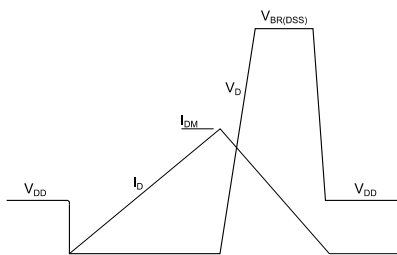

AM01472v1

Figure 23: Switching time waveform

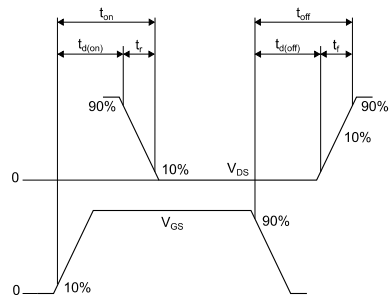

AM01473v1

4 Package information

In order to meet environmental requirements, ST offers these devices in different grades of ECOPACK® packages, depending on their level of environmental compliance. ECOPACK® specifications, grade definitions and product status are available at: www.st.com. ECOPACK® is an ST trademark.

4.1 DPAK (TO-252) type A2 package information

Figure 24: DPAK (TO-252) type A2 package outline

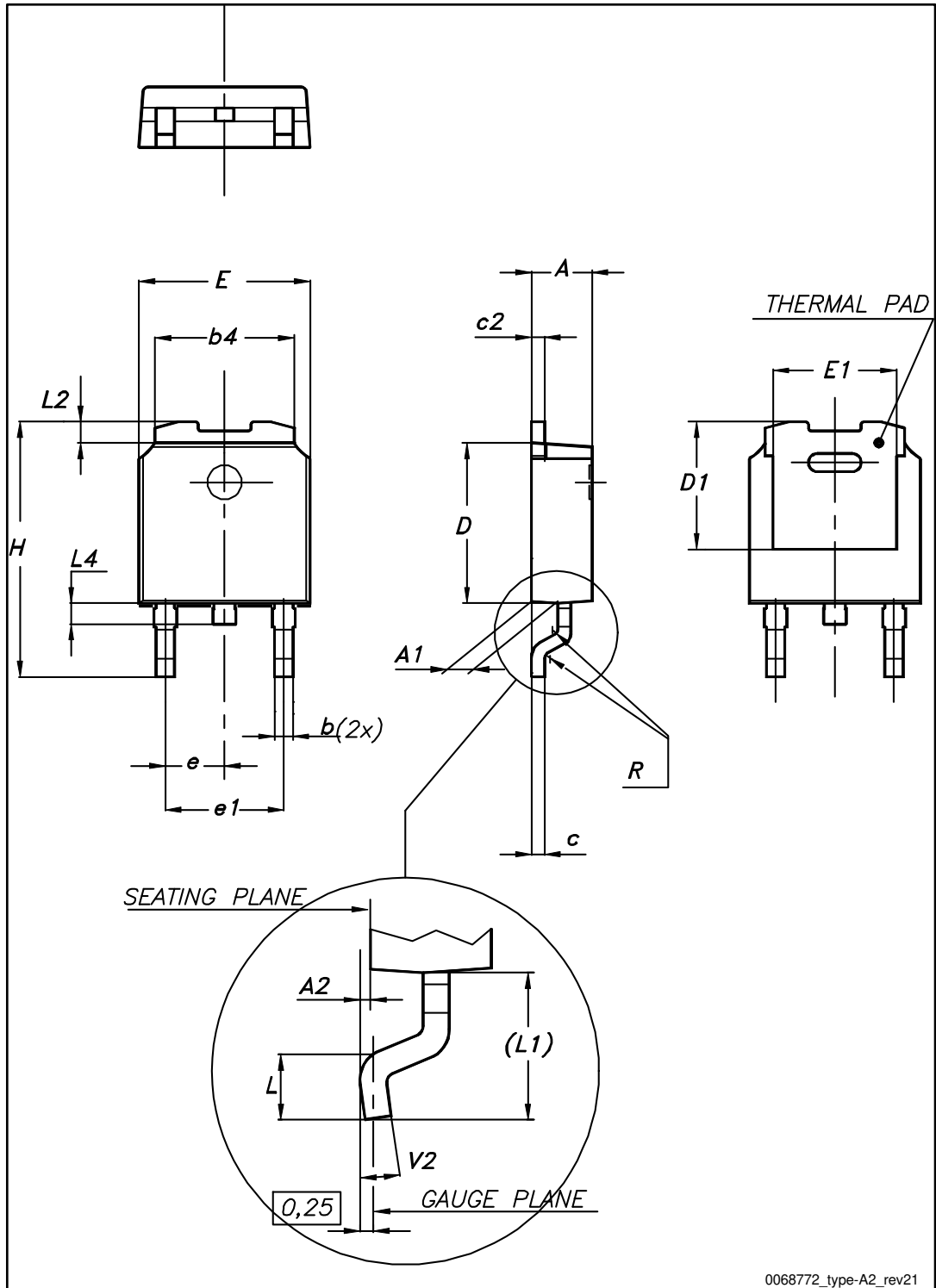
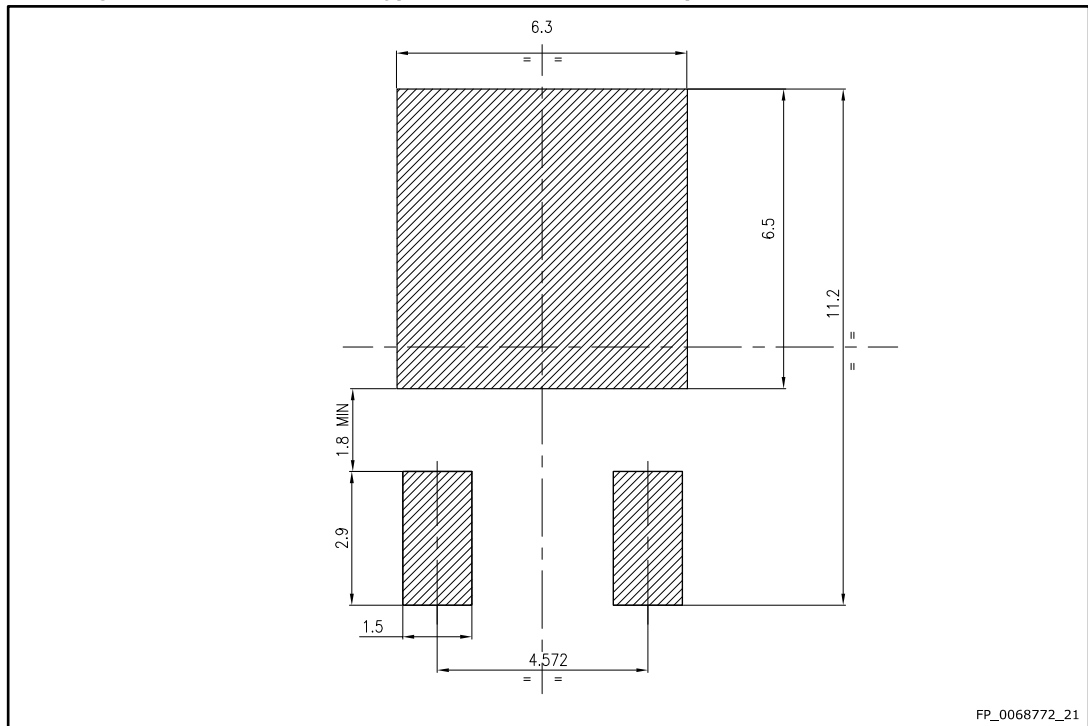

Table 10: DPAK (TO-252) type A2 mechanical data

Dim.	mm		
	Min.	Typ.	Max.
A	2.20		2.40
A1	0.90		1.10
A2	0.03		0.23
b	0.64		0.90
b4	5.20		5.40
c	0.45		0.60
c2	0.48		0.60
D	6.00		6.20
D1	4.95	5.10	5.25
E	6.40		6.60
E1	5.10	5.20	5.30
e	2.16	2.28	2.40
e1	4.40		4.60
H	9.35		10.10
L	1.00		1.50
L1	2.60	2.80	3.00
L2	0.65	0.80	0.95
L4	0.60		1.00
R		0.20	
V2	0°		8°

Figure 25: DPAK (TO-252) type A2 recommended footprint (dimensions are in mm)



4.2 DPAK (TO-252) type C2 package information

Figure 26: DPAK (TO-252) type C2 package outline

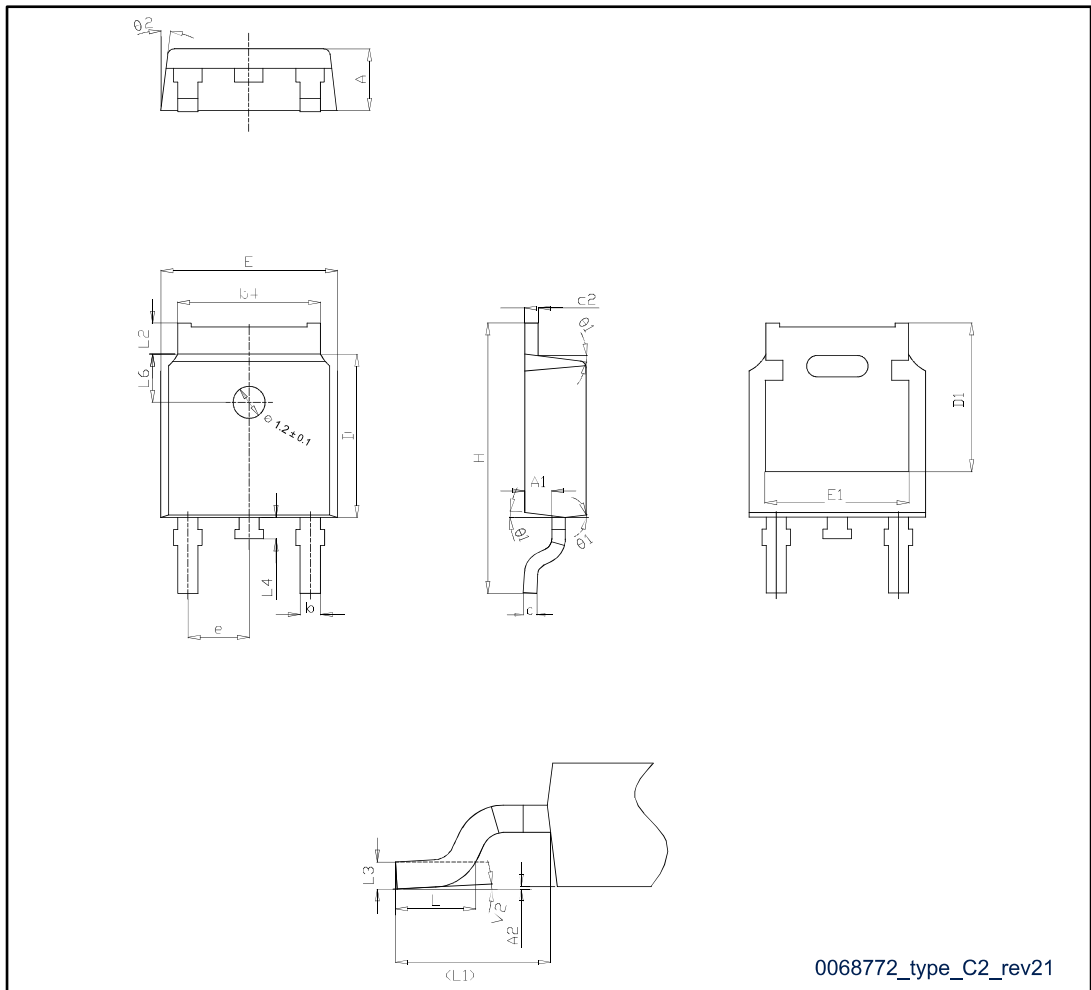
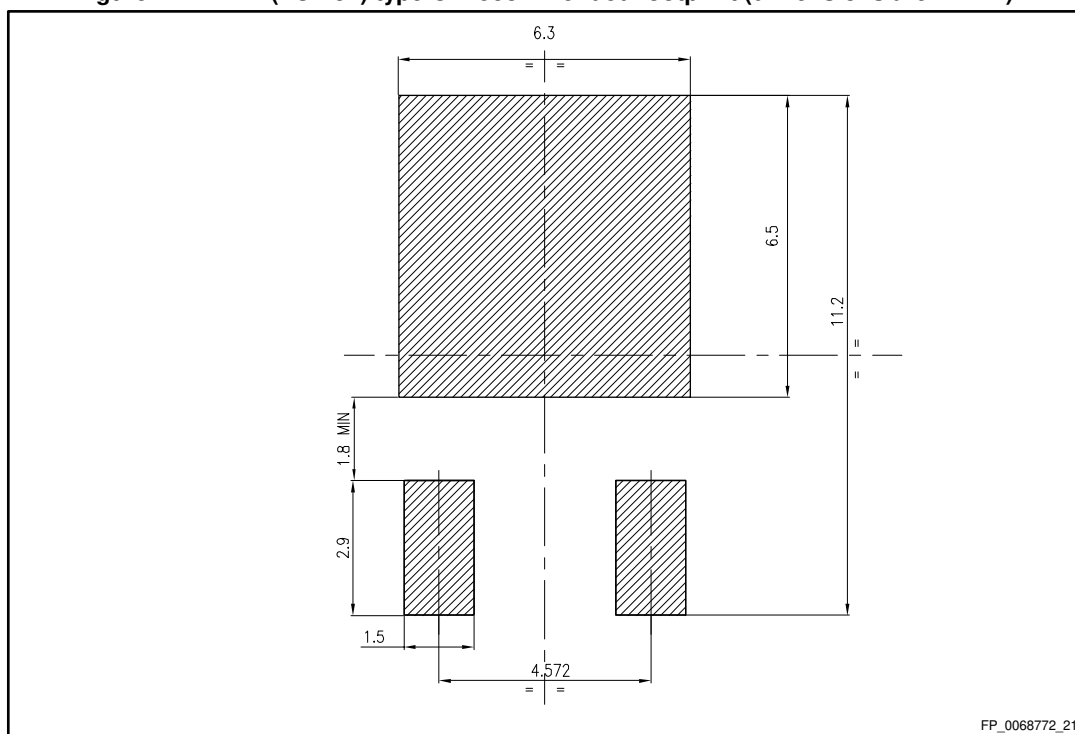

Table 11: DPAK (TO-252) type C2 mechanical data

Dim.	mm		
	Min.	Typ.	Max.
A	2.20	2.30	2.38
A1	0.90	1.01	1.10
A2	0.00		0.10
b	0.72		0.85
b4	5.13	5.33	5.46
c	0.47		0.60
c2	0.47		0.60
D	6.00	6.10	6.20
D1	5.10		5.60
E	6.50	6.60	6.70
E1	5.20		5.50
e	2.186	2.286	2.386
H	9.80	10.10	10.40
L	1.40	1.50	1.70
L1	2.90 REF		
L2	0.90		1.25
L3	0.51 BSC		
L4	0.60	0.80	1.00
L6	1.80 BSC		
θ1	5°	7°	9°
θ2	5°	7°	9°
V2	0°		8°

Figure 27: DPAK (TO-252) type C2 recommended footprint (dimensions are in mm)



4.3 DPAK (TO-252) packing information

Figure 28: DPAK (TO-252) tape outline

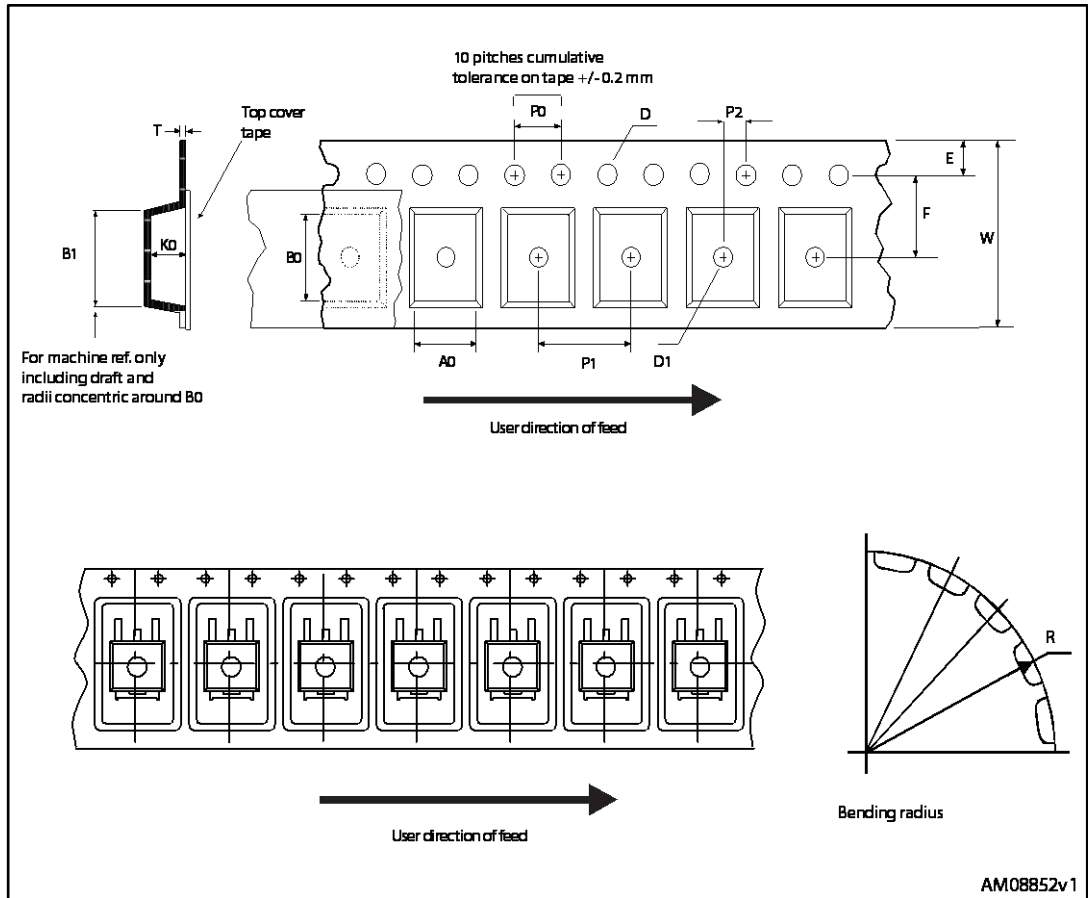
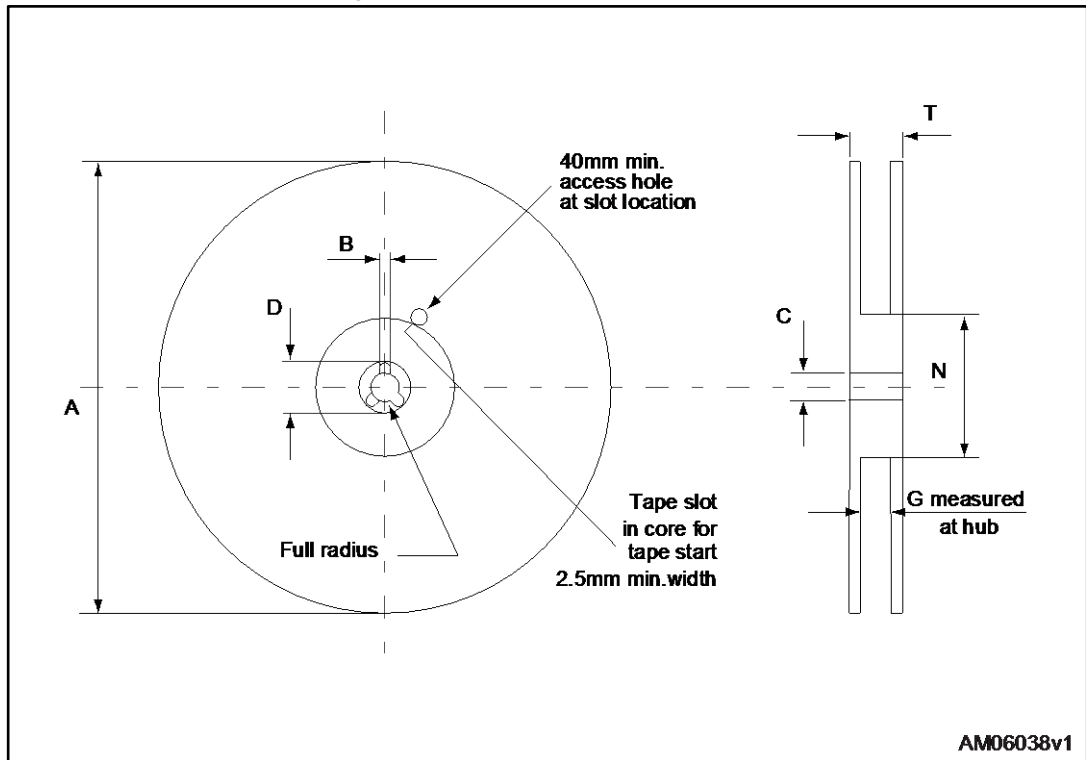

Figure 29: DPAK (TO-252) reel outline



AM06038v1

Table 12: DPAK (TO-252) tape and reel mechanical data

Tape			Reel		
Dim.	mm		Dim.	mm	
	Min.	Max.		Min.	Max.
A0	6.8	7	A		330
B0	10.4	10.6	B	1.5	
B1		12.1	C	12.8	13.2
D	1.5	1.6	D	20.2	
D1	1.5		G	16.4	18.4
E	1.65	1.85	N	50	
F	7.4	7.6	T		22.4
K0	2.55	2.75			
P0	3.9	4.1	Base qty.		2500
P1	7.9	8.1	Bulk qty.		2500
P2	1.9	2.1			
R	40				
T	0.25	0.35			
W	15.7	16.3			

4.4 TO-220FP package information

Figure 30: TO-220FP package outline

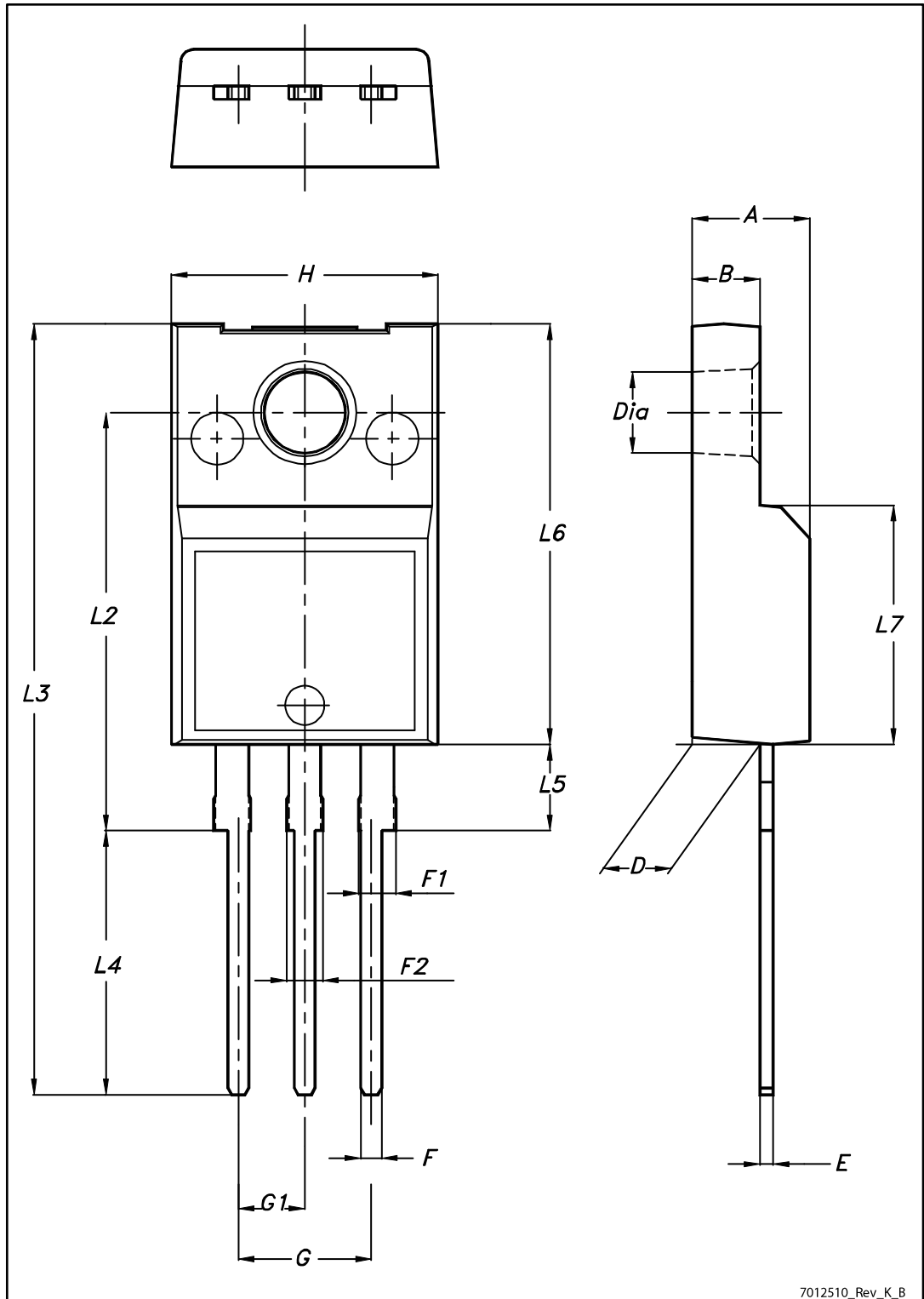

7012510_Rev_K_B

Table 13: TO-220FP package mechanical data

Dim.	mm		
	Min.	Typ.	Max.
A	4.4		4.6
B	2.5		2.7
D	2.5		2.75
E	0.45		0.7
F	0.75		1
F1	1.15		1.70
F2	1.15		1.70
G	4.95		5.2
G1	2.4		2.7
H	10		10.4
L2		16	
L3	28.6		30.6
L4	9.8		10.6
L5	2.9		3.6
L6	15.9		16.4
L7	9		9.3
Dia	3		3.2

4.5 TO-220 type A package information

Figure 31: TO-220 type A package outline

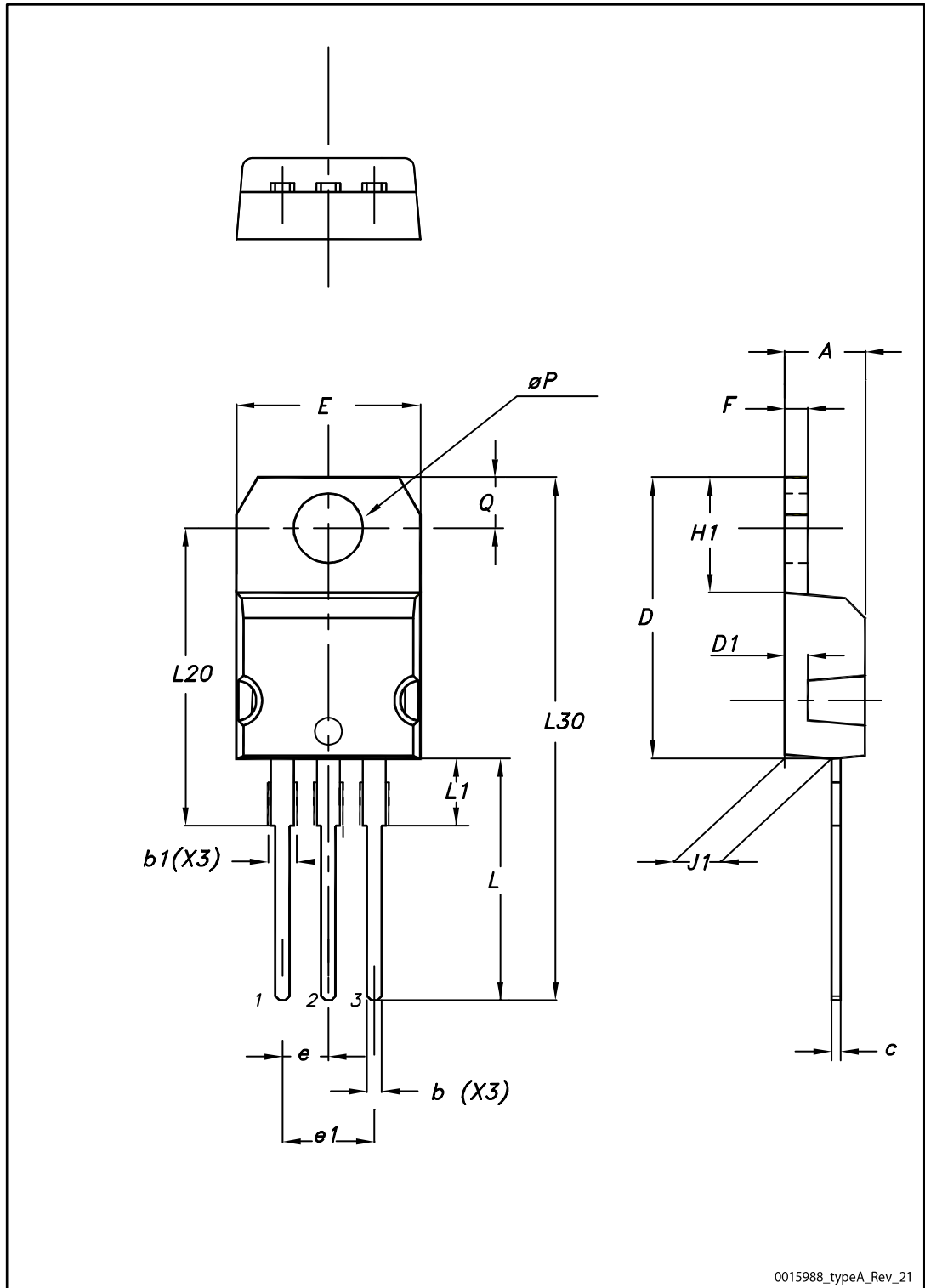

Table 14: TO-220 type A mechanical data

Dim.	mm		
	Min.	Typ.	Max.
A	4.40		4.60
b	0.61		0.88
b1	1.14		1.55
c	0.48		0.70
D	15.25		15.75
D1		1.27	
E	10.00		10.40
e	2.40		2.70
e1	4.95		5.15
F	1.23		1.32
H1	6.20		6.60
J1	2.40		2.72
L	13.00		14.00
L1	3.50		3.93
L20		16.40	
L30		28.90	
øP	3.75		3.85
Q	2.65		2.95

4.6 IPAK (TO-251) type A package information

Figure 32: IPAK (TO-251) type A package outline

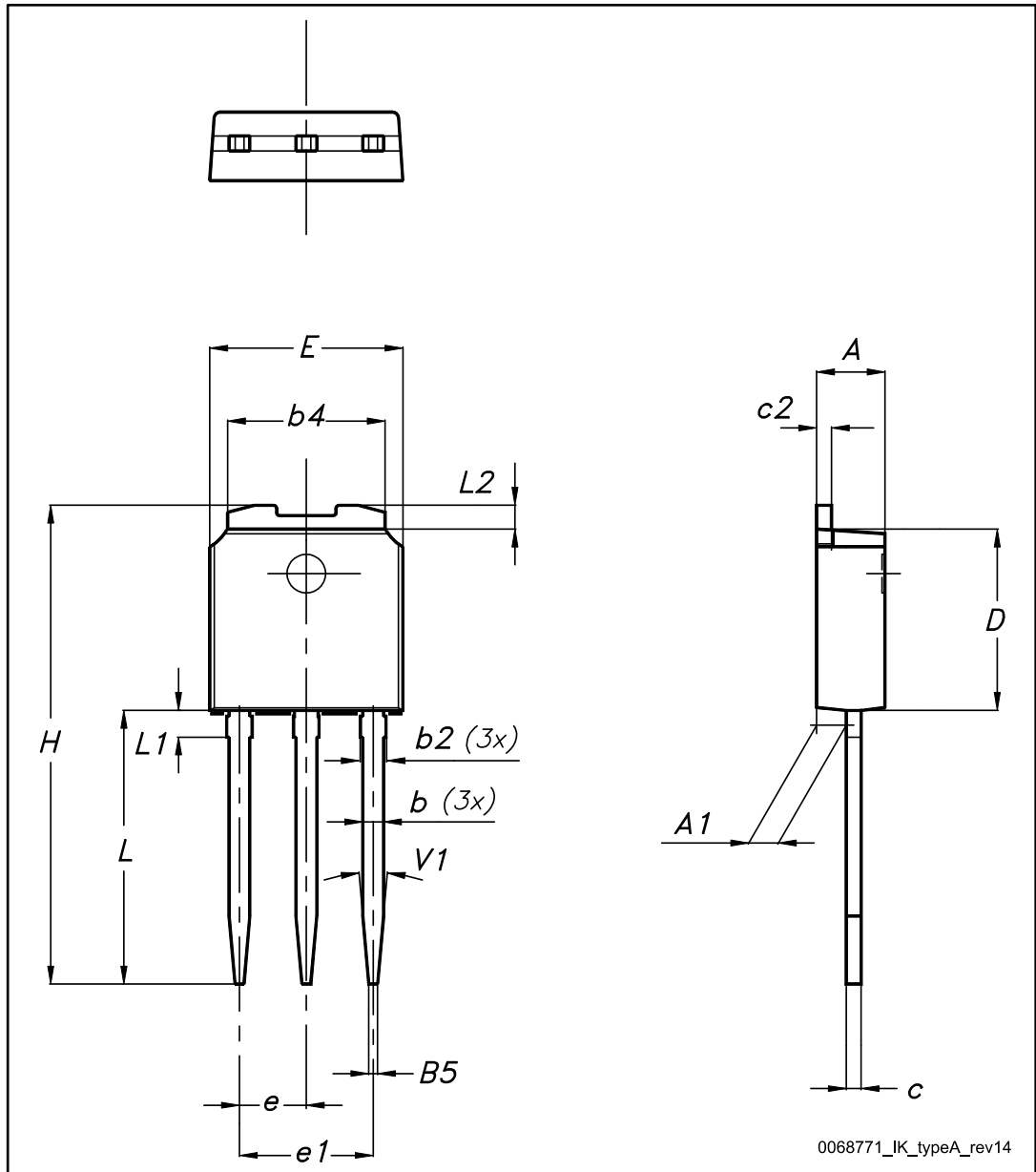

Table 15: IPAK (TO-251) type A package mechanical data

Dim.	mm		
	Min.	Typ.	Max.
A	2.20		2.40
A1	0.90		1.10
b	0.64		0.90
b2			0.95
b4	5.20		5.40
B5		0.30	
c	0.45		0.60
c2	0.48		0.60
D	6.00		6.20
E	6.40		6.60
e		2.28	
e1	4.40		4.60
H		16.10	
L	9.00		9.40
L1	0.80		1.20
L2		0.80	1.00
V1		10°	

5 Revision history

Table 16: Document revision history

Date	Revision	Changes
08-May-2013	1	First release.
18-Sep-2013	2	Document status promoted from preliminary to production data. Added <i>Section 2.1: Electrical characteristics (curves)</i> . Updated DPAK mechanical data.
25-Sep-2013	3	Inserted <i>Figure 17: Source-drain diode forward characteristics</i> .
04-Jan-2017	4	Added IPAK package. Modified title, features and description on cover page. Modified <i>Table 2: "Absolute maximum ratings"</i> , <i>Table 3: "Thermal data"</i> , <i>Table 5: "On/off-state"</i> . Modified <i>Figure 11: "Static drain-source on-resistance"</i> . Updated <i>Section 4: "Package information"</i> . Minor text changes.