



Chipsmall Limited consists of a professional team with an average of over 10 year of expertise in the distribution of electronic components. Based in Hongkong, we have already established firm and mutual-benefit business relationships with customers from,Europe,America and south Asia,supplying obsolete and hard-to-find components to meet their specific needs.

With the principle of “Quality Parts,Customers Priority,Honest Operation,and Considerate Service”,our business mainly focus on the distribution of electronic components. Line cards we deal with include Microchip,ALPS,ROHM,Xilinx,Pulse,ON,Everlight and Freescale. Main products comprise IC,Modules,Potentiometer,IC Socket,Relay,Connector.Our parts cover such applications as commercial,industrial, and automotives areas.

We are looking forward to setting up business relationship with you and hope to provide you with the best service and solution. Let us make a better world for our industry!



Contact us

Tel: +86-755-8981 8866 Fax: +86-755-8427 6832

Email & Skype: info@chipsmall.com Web: www.chipsmall.com

Address: A1208, Overseas Decoration Building, #122 Zhenhua RD., Futian, Shenzhen, China



Dual NPN high voltage transistors in a single package

Datasheet — production data

Features

- Low $V_{CE(sat)}$
- Simplified circuit design
- Reduced component count
- Fast switching speed

Applications

- Compact fluorescent lamp (CFL) 220 V mains
- Electronic ballast for fluorescent lighting

Description

The device is a dual NPN high voltage power transistor manufactured using multi-epitaxial planar technology. It is housed in dual-island DIP-8 package with separated terminals to provide a high degree of assembly flexibility.

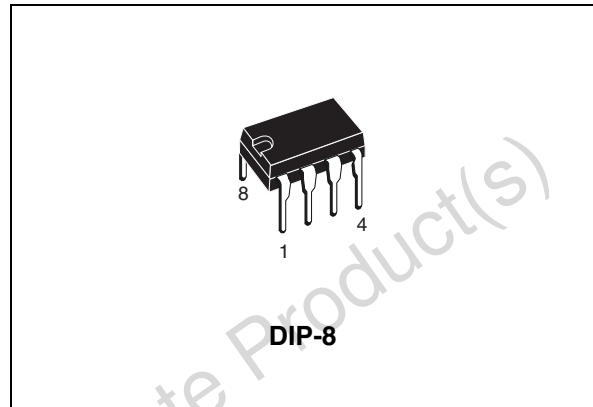

Figure 1. Internal schematic diagram

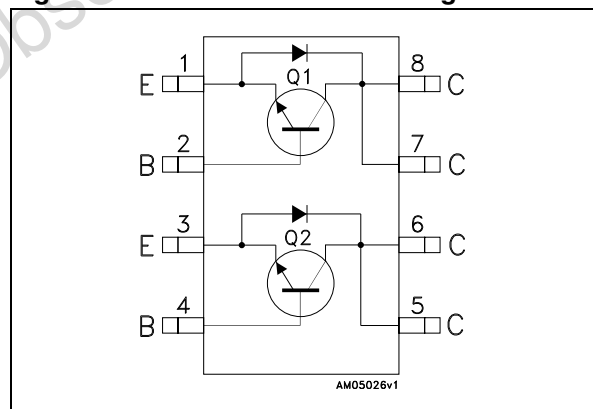

Table 1. Device summary

Order code	Marking	Package	Packaging
STD845DN40	D845DN40	DIP-8	Tube

1 Electrical ratings

Table 2. Absolute maximum ratings

Symbol	Parameter	Value	Unit
V_{CBO}	Collector-base voltage ($I_E = 0$)	700	V
V_{CEO}	Collector-emitter voltage ($I_B = 0$)	400	V
V_{EBO}	Emitter-base voltage ($I_C = 0$, $I_B = 2$ A, $t_p < 10$ ms)	$V_{(BR)EBO}$	V
I_C	Collector current	4	A
I_{CM}	Collector peak current ($t_p < 5$ ms)	8	A
I_B	Base current	2	A
I_{BM}	Base peak current ($t_p < 5$ ms)	4	A
P_{TOT}	Total dissipation at $T_{amb} = 25$ °C single transistor	3	W
	Total dissipation at $T_{case} = 25$ °C single transistor	45	W
T_{STG}	Storage temperature	-65 to 150	°C
T_J	Max. operating junction temperature	150	°C

Table 3. Thermal data

Symbol	Parameter	Value	Unit
$R_{thJA}^{(1)}$	Thermal resistance junction-ambient (single transistor)	42	°C/W
R_{thJC}	Thermal resistance junction-case (single transistor)	2.7	°C/W

1. Device mounted on PCB area of 25 mm².

2 Electrical characteristics

$T_{\text{case}} = 25\text{ °C}$ unless otherwise specified.

Table 4. Electrical characteristics

Symbol	Parameter	Test conditions	Min.	Typ.	Max.	Unit
I_{CES}	Collector cut-off current ($V_{\text{BE}} = 0$)	$V_{\text{CE}} = 700\text{ V}$			100	μA
		$V_{\text{CE}} = 700\text{ V}$ $T_{\text{c}} = 125\text{ °C}$			500	μA
I_{CEO}	Collector cut-off current ($I_{\text{B}} = 0$)	$V_{\text{CE}} = 400\text{ V}$			250	μA
$V_{(\text{BR})\text{EBO}}$	Emitter-base breakdown voltage ($I_{\text{C}} = 0$)	$I_{\text{E}} = 10\text{ mA}$	9		18	V
$V_{\text{CEO(sus)}}^{(1)}$	Collector-emitter sustaining voltage ($I_{\text{B}} = 0$)	$I_{\text{C}} = 100\text{ mA}$	400			V
$V_{\text{CE(sat)}}^{(1)}$	Collector-emitter saturation voltage	$I_{\text{C}} = 0.5\text{ A}$ $I_{\text{B}} = 0.1\text{ A}$			0.7	V
		$I_{\text{C}} = 1\text{ A}$ $I_{\text{B}} = 0.2\text{ A}$			1	V
		$I_{\text{C}} = 2.5\text{ A}$ $I_{\text{B}} = 0.5\text{ A}$		0.5	1.5	V
		$I_{\text{C}} = 4\text{ A}$ $I_{\text{B}} = 1\text{ A}$				V
$V_{\text{BE(sat)}}^{(1)}$	Base-emitter saturation voltage	$I_{\text{C}} = 0.5\text{ A}$ $I_{\text{B}} = 0.1\text{ A}$			1.1	V
		$I_{\text{C}} = 1\text{ A}$ $I_{\text{B}} = 0.2\text{ A}$			1.2	V
		$I_{\text{C}} = 2.5\text{ A}$ $I_{\text{B}} = 0.5\text{ A}$			1.3	V
$h_{\text{FE}}^{(1)}$	DC current gain	$I_{\text{C}} = 10\text{ mA}$ $V_{\text{CE}} = 5\text{ V}$	10			
		$I_{\text{C}} = 2\text{ A}$ $V_{\text{CE}} = 5\text{ V}$	12		32	
V_{F}	Diode forward voltage	$I_{\text{F}} = 2\text{ A}$			2.5	V
t_{s} t_{f}	Resistive load Storage time Fall time	$I_{\text{C}} = 2\text{ A}$				
		$I_{\text{B(on)}} = -I_{\text{B(off)}} = 400\text{ mA}$ $V_{\text{CC}} = 125\text{ V}$ $t_{\text{p}} = 30\text{ }\mu\text{s}$		2.5		μs
t_{s} t_{f}	Inductive load Storage time Fall time	$I_{\text{C}} = 2\text{ A}$, $V_{\text{CC}} = 200\text{ V}$				
		$V_{\text{BE(off)}} = -5\text{ V}$ $I_{\text{B(on)}} = 400\text{ mA}$ $R_{\text{BB}} = 0$, $L = 200\text{ }\mu\text{H}$		0.6		μs
				0.1		μs

1. Pulse test: pulse duration $\leq 300\text{ }\mu\text{s}$, duty cycle $\leq 2\%$.

2.1 Electrical characteristics (curves)

Figure 2. DC current gain ($V_{CE} = 1.5\text{ V}$)

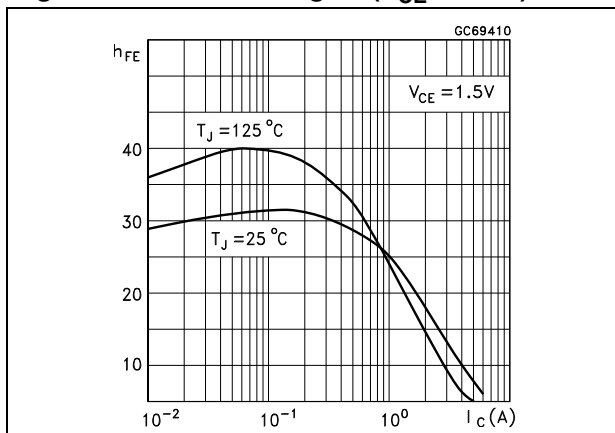

Figure 3. DC current gain ($V_{CE} = 5\text{ V}$)

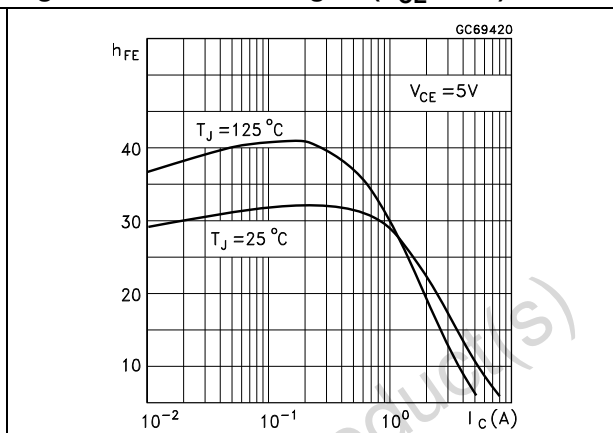

Figure 4. Collector-emitter saturation voltage Figure 5. Base-emitter saturation voltage

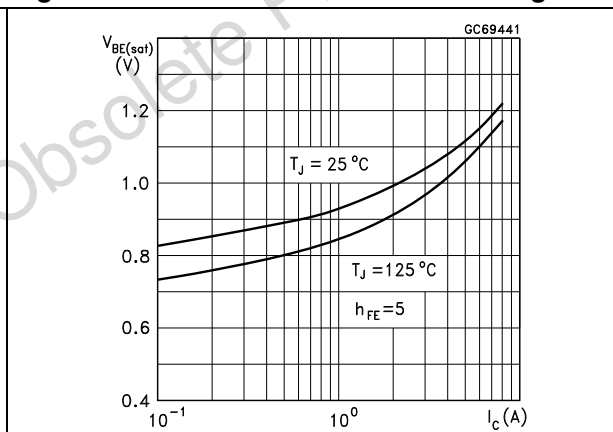
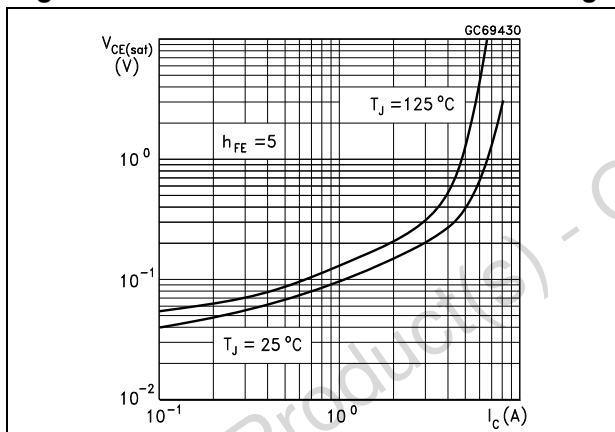

Figure 6. Inductive load fall time

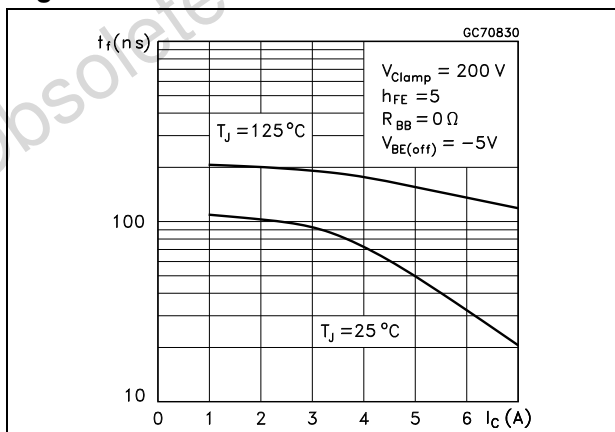

Figure 7. Inductive load storage time

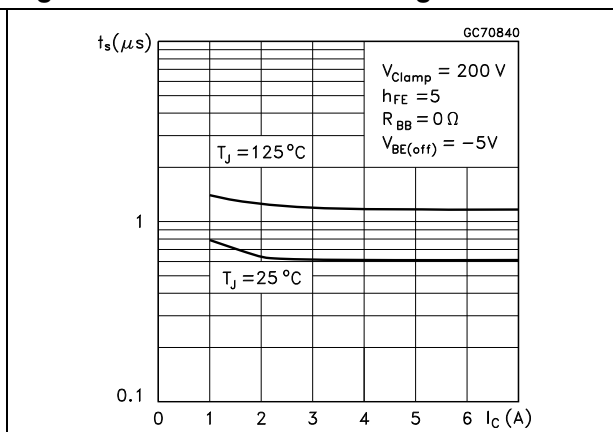

Figure 8. Resistive load fall time

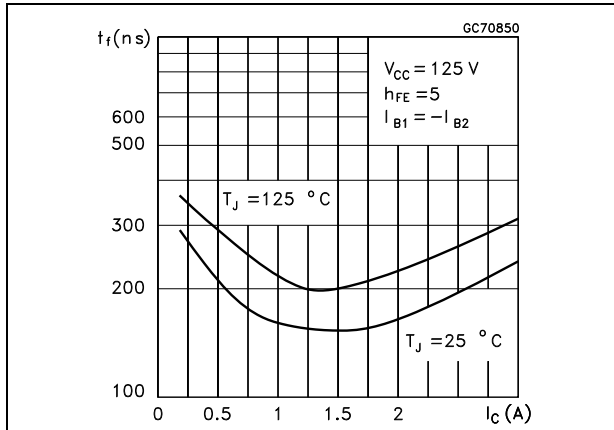

Figure 9. Resistive load storage time

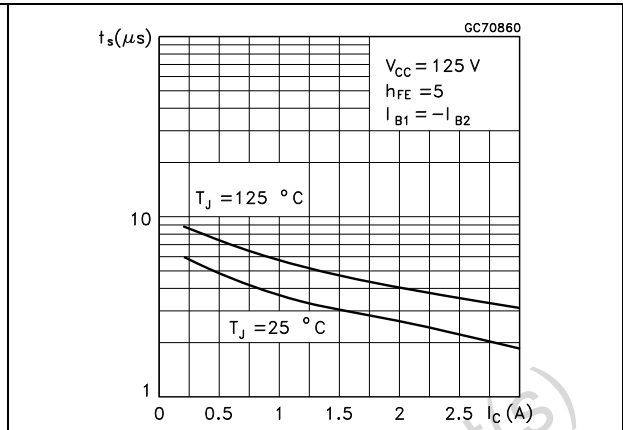
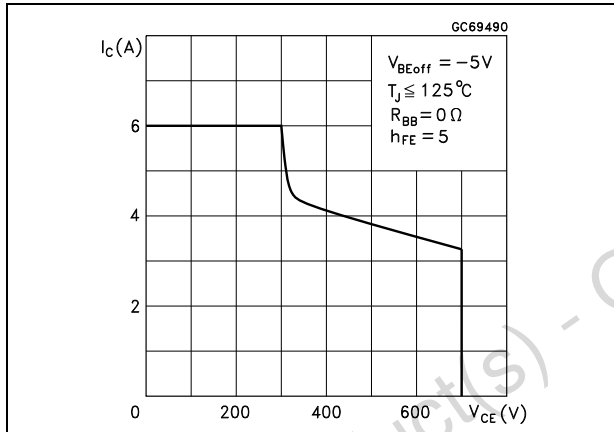
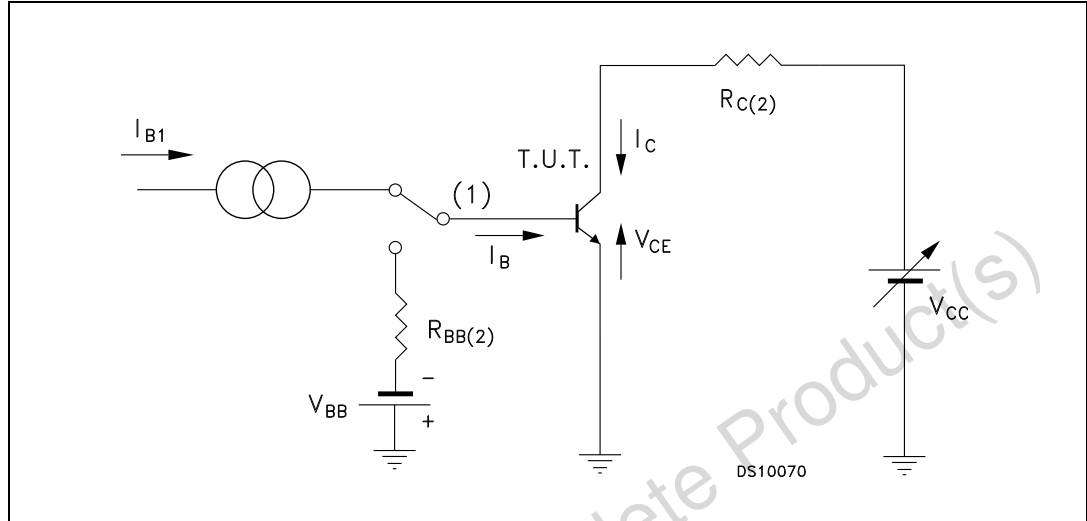

Figure 10. Reverse biased safe operating area



3 Test circuits

Figure 11. Resistive load switching test circuit



- 1. Fast electronic switch
- 2. Non-inductive resistor

Figure 12. Inductive load switching test circuit

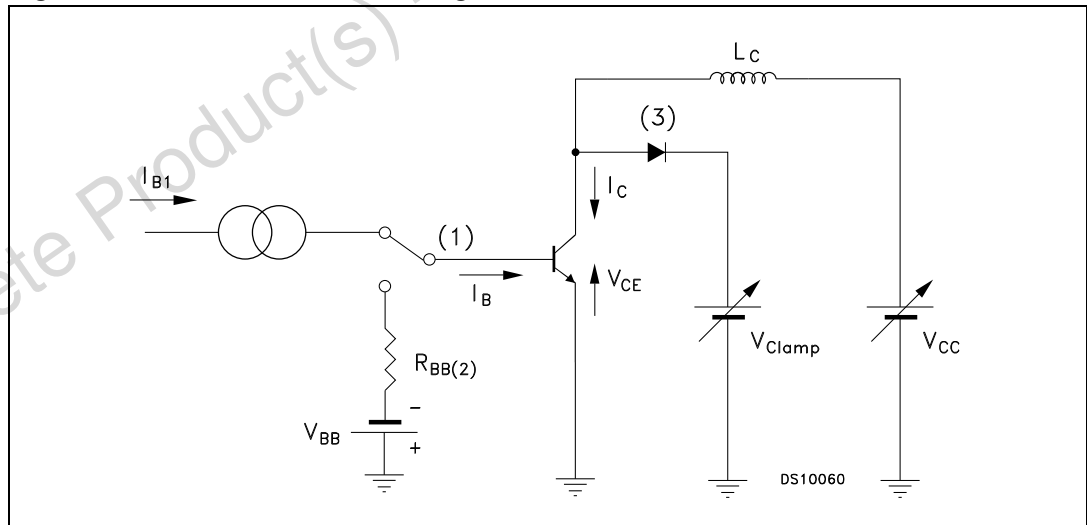

- 1. Fast electronic switch
- 2. Non-inductive resistor
- 3. Fast recovery rectifier

4 Package mechanical data

In order to meet environmental requirements, ST offers these devices in different grades of ECOPACK[®] packages, depending on their level of environmental compliance. ECOPACK[®] specifications, grade definitions and product status are available at: www.st.com. ECOPACK[®] is an ST trademark.

Table 5. DIP-8 mechanical data

Dim.	mm.		
	Min.	Typ.	Max.
A			4.80
A1	0.50		
A2	3.10		3.50
A3	1.40		1.60
b	0.38		0.55
b1	0.38		0.51
b2	1.47		1.57
b3	0.89		1.09
c	0.21		0.35
c1	0.20		0.30
D	9.10		9.30
D1	0.13		
E	7.62		8.25
E1	6.25		6.45
e		2.54	
eA		7.62	
eB	7.62		10.90
eC	0		1.52
L	2.92		3.81

Figure 13. Drawing dimension DIP-8

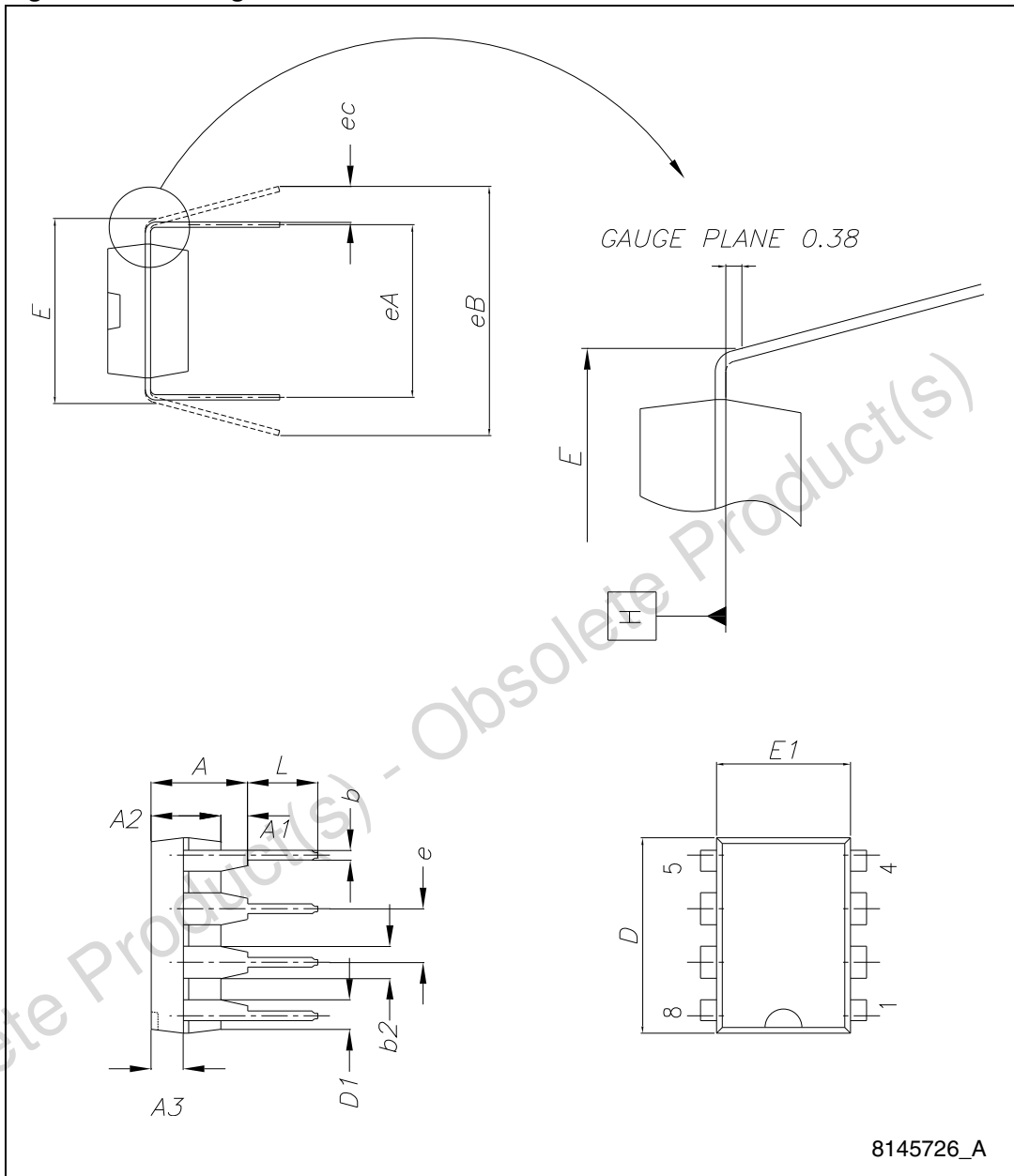

5 Revision history

Table 6. Document revision history

Date	Revision	Changes
03-Mar-2010	1	Initial release.
16-Apr-2010	2	Inserted P_{TOT} and R_{thJA} values Table 2 and Table 3 on page 2 .
23-Oct-2012	3	Modified P_{TOT} and R_{thJA} values in Table 2 and Table 3 on page 2 .

Obsolete Product(s) - Obsolete Product(s)

Please Read Carefully:

Information in this document is provided solely in connection with ST products. STMicroelectronics NV and its subsidiaries ("ST") reserve the right to make changes, corrections, modifications or improvements, to this document, and the products and services described herein at any time, without notice.

All ST products are sold pursuant to ST's terms and conditions of sale.

Purchasers are solely responsible for the choice, selection and use of the ST products and services described herein, and ST assumes no liability whatsoever relating to the choice, selection or use of the ST products and services described herein.

No license, express or implied, by estoppel or otherwise, to any intellectual property rights is granted under this document. If any part of this document refers to any third party products or services it shall not be deemed a license grant by ST for the use of such third party products or services, or any intellectual property contained therein or considered as a warranty covering the use in any manner whatsoever of such third party products or services or any intellectual property contained therein.

UNLESS OTHERWISE SET FORTH IN ST'S TERMS AND CONDITIONS OF SALE ST DISCLAIMS ANY EXPRESS OR IMPLIED WARRANTY WITH RESPECT TO THE USE AND/OR SALE OF ST PRODUCTS INCLUDING WITHOUT LIMITATION IMPLIED WARRANTIES OF MERCHANTABILITY, FITNESS FOR A PARTICULAR PURPOSE (AND THEIR EQUIVALENTS UNDER THE LAWS OF ANY JURISDICTION), OR INFRINGEMENT OF ANY PATENT, COPYRIGHT OR OTHER INTELLECTUAL PROPERTY RIGHT.

UNLESS EXPRESSLY APPROVED IN WRITING BY TWO AUTHORIZED ST REPRESENTATIVES, ST PRODUCTS ARE NOT RECOMMENDED, AUTHORIZED OR WARRANTED FOR USE IN MILITARY, AIR CRAFT, SPACE, LIFE SAVING, OR LIFE SUSTAINING APPLICATIONS, NOR IN PRODUCTS OR SYSTEMS WHERE FAILURE OR MALFUNCTION MAY RESULT IN PERSONAL INJURY, DEATH, OR SEVERE PROPERTY OR ENVIRONMENTAL DAMAGE. ST PRODUCTS WHICH ARE NOT SPECIFIED AS "AUTOMOTIVE GRADE" MAY ONLY BE USED IN AUTOMOTIVE APPLICATIONS AT USER'S OWN RISK.

Resale of ST products with provisions different from the statements and/or technical features set forth in this document shall immediately void any warranty granted by ST for the ST product or service described herein and shall not create or extend in any manner whatsoever, any liability of ST.

ST and the ST logo are trademarks or registered trademarks of ST in various countries.

Information in this document supersedes and replaces all information previously supplied.

The ST logo is a registered trademark of STMicroelectronics. All other names are the property of their respective owners.

© 2012 STMicroelectronics - All rights reserved

STMicroelectronics group of companies

Australia - Belgium - Brazil - Canada - China - Czech Republic - Finland - France - Germany - Hong Kong - India - Israel - Italy - Japan - Malaysia - Malta - Morocco - Philippines - Singapore - Spain - Sweden - Switzerland - United Kingdom - United States of America

www.st.com