



Chipsmall Limited consists of a professional team with an average of over 10 year of expertise in the distribution of electronic components. Based in Hongkong, we have already established firm and mutual-benefit business relationships with customers from,Europe,America and south Asia,supplying obsolete and hard-to-find components to meet their specific needs.

With the principle of “Quality Parts,Customers Priority,Honest Operation,and Considerate Service”,our business mainly focus on the distribution of electronic components. Line cards we deal with include Microchip,ALPS,ROHM,Xilinx,Pulse,ON,Everlight and Freescale. Main products comprise IC,Modules,Potentiometer,IC Socket,Relay,Connector.Our parts cover such applications as commercial,industrial, and automotives areas.

We are looking forward to setting up business relationship with you and hope to provide you with the best service and solution. Let us make a better world for our industry!



Contact us

Tel: +86-755-8981 8866 Fax: +86-755-8427 6832

Email & Skype: info@chipsmall.com Web: www.chipsmall.com

Address: A1208, Overseas Decoration Building, #122 Zhenhua RD., Futian, Shenzhen, China



STDP2650 Advanced DisplayPort to HDMI converter

Datasheet

Rev A



MegaChips' Proprietary Information

MegaChips reserves the right to make any change herein at any time without prior notice. MegaChips does not assume any responsibility or liability arising out of application or use of any product or service described herein except as explicitly agreed upon.

Features

- DisplayPort® (DP) dual-mode receiver
 - DP 1.2a/HDMI 1.4 compliant
 - Link rate HBR2/HBR/RBR
 - 1, 2, or 4 lanes
 - AUX CH 1 Mbps
 - Supports eDP operation
 - DC coupled TMDS input up to 2.97Gbps/data pair
- HDMI 1.4 transmitter
 - Max data rate up to 2.97 Gbps/data pair
 - Color depth up to 48 bits
 - 3D video timings
 - CEC
- Operates as DP-to-HDMI protocol converter or HDMI re-timer
- SPDIF audio output
 - 192 kHz/24 bits
 - Compressed/LPCM
- HDCP repeater with embedded keys
- ASSR -- eDP display authentication option
- AUX to I2C bridge for EDID/MCCS pass through
- Device configuration options

- SPI Flash
- I2C host interface
- Spread spectrum on DisplayPort interface for EMI reduction
- Deep color support
 - RGB/YCC (4:4:4) – 16-bit color
 - YCC (4:2:2) – 16-bit color
 - Color space conversion – YUV to RGB and RGB to YUV
- Bandwidth
 - Video resolution up to 4K x 2K @ 30 Hz; 1920 x 1080 @ 120 Hz
 - Audio 7.1 Ch up to 192 kHz sample rate
- Low power operation; active 462 mW, standby 21 mW
- Package
 - 81 BGA (8 x 8 mm)
- Power supply voltages
 - 3.3 V I/O; 1.2 V core

Applications

- DisplayPort to HDMI bridge for TVs and projectors
- Audio-video accessory (dongle) for desktop, notebook computers, and tablets

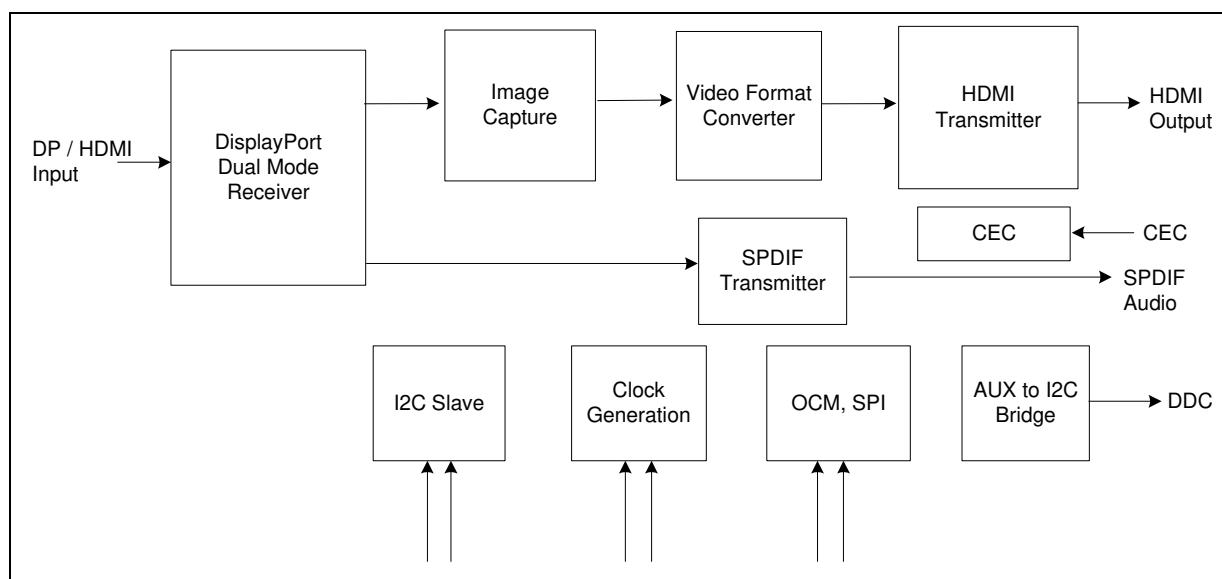

Contents

1.	Description	7
2.	Application overview	8
3.	Feature attributes	9
3.1	Input interface	9
3.2	Output interface	9
3.3	Operating modes	9
3.4	Deep color support	10
3.5	Supported video timings	10
3.6	Supported audio timings	10
3.7	Control channel interfaces	10
3.8	HDCP 1.3 support	10
3.9	Package	10
3.10	Power supply voltages	11
3.11	ESD	11
4.	BGA footprint and pin lists	12
4.1	Ball grid array diagram	12
4.2	Full pin list sorted by pin number	14
5.	Connections	16
5.1	Pin list	16
5.2	Bootstrap configuration	19
6.	Package specifications	21
6.1	Package drawing	21
6.2	BGA8X8 dimensions	22
6.3	Marking field template and descriptors	23
6.4	Classification reflow profile	23
7.	Electrical specifications	24
7.1	Absolute maximum ratings	24

7.2	DC characteristics	24
7.3	AC characteristics	25
7.3.1	DisplayPort receiver	26
7.3.2	HDMI receiver	27
7.3.3	HDMI transmitter	28
7.3.4	Crystal specification	28
7.3.5	I2C interface timing	29
7.3.6	SPI interface timing	30
8.	Ordering information	32
9.	Revision history	33

List of Tables

Table 1.	Key to BGA diagrams	12
Table 2.	Pin list	14
Table 3.	DisplayPort receiver pins	16
Table 4.	System function pins	17
Table 5.	General purpose input/output and multi-function pins	17
Table 6.	Transmitter pins	18
Table 7.	System power and ground	19
Table 8.	Reserved pins	19
Table 9.	Bootstrap configuration	20
Table 10.	Field descriptors	23
Table 11.	Absolute maximum ratings	24
Table 12.	DC characteristics	24
Table 13.	Maximum speed of operation	25
Table 14.	DisplayPort receiver electrical parameters	26
Table 15.	HDMI receiver DC characteristics	27
Table 16.	HDMI receiver AC characteristics	27
Table 17.	HDMI transmitter DC characteristics	28
Table 18.	HDMI transmitter AC characteristics	28
Table 19.	Crystal specifications	28
Table 20.	I2C interface timing	29
Table 21.	SPI interface timing, VDD = 3.3V	30
Table 22.	Order codes	32
Table 23.	Document revision history	33

List of Figures

Figure 1.	STDP2650 in notebook accessory application	8
Figure 2.	STDP2650 inside TV application	8
Figure 3.	STDP2650 BGA diagram	13
Figure 4.	Package drawing	21
Figure 5.	Package dimensions.	22
Figure 6.	Marking template	23
Figure 7.	HDMI and DVI receiver AC characteristics	28
Figure 8.	I2C Timing	30
Figure 9.	SPI output or serial interface SPI ROM input timing	31
Figure 10.	SPI input or serial interface SPI ROM output timing	31

1. Description

The STDP2650 is a high-speed DisplayPort-to-HDMI protocol converter or HDMI-to-HDMI re-timer IC for applications such as audio-video cable accessories, docking stations, and TV front-end design. This device includes a VESA DP Standard Ver.1.2a compliant dual-mode receiver and an HDMI 1.4 compliant transmitter. The DisplayPort dual-mode input port comprises four main lanes, AUX CH, and HPD signal. The main lanes can receive either a DP or TMDS signal format. The HDMI output port includes DDC, CEC, and HPD support.

The STDP2650 uses MegaChips' latest generation DisplayPort dual-mode receiver technology that supports HBR2 speed, a data rate of 5.4 Gbps per lane with a total bandwidth of 21.6 Gbps link rate. It can also receive TMDS signal up to 2.97 Gbps per data pair. The HDMI transmitter is capable of supporting link rate up to 2.97 Gbps that corresponds to a pixel rate of 297 MHz, adequate for handling video resolution up to FHD 120 Hz 3D formats. This device delivers deep color video up to 16-bits per color at 1080p 60 Hz and lower video resolutions. The STDP2650 allows audio transport from the source to desired audio rendering devices over the HDMI output or through the SPDIF port. The audio signal from the source can be routed simultaneously to HDMI and SPDIF output ports. For example, the STDP2650 allows routing of any two audio channels on the SPDIF port, while transporting up to eight channels on the HDMI port.

The STDP2650 supports RGB and YCbCr colorimetric formats with color depth of 16, 12, 10, and 8 bits. This device features HDCP 1.3 content protection scheme with an embedded key option for secure transmission of digital audio-video content. It also operates as an HDCP repeater for the downstream sink. The eDP authentication option ASSR (Alternative Scrambler Seed Reset) is supported for embedded application.

The AUX-to-I2C translator in the STDP2650 allows the upstream DisplayPort source to access EDID and transfer MCCS commands to a downstream sink over the HDMI interface. This device has an on-chip microcontroller with SPI and I2C host interface for system configuration purposes. The STDP2650 can be configured with an external SPI Flash for custom applications. In addition, it allows register level configuration from an external host controller through I2C interface.

2. Application overview

Figure 1. STDP2650 in notebook accessory application

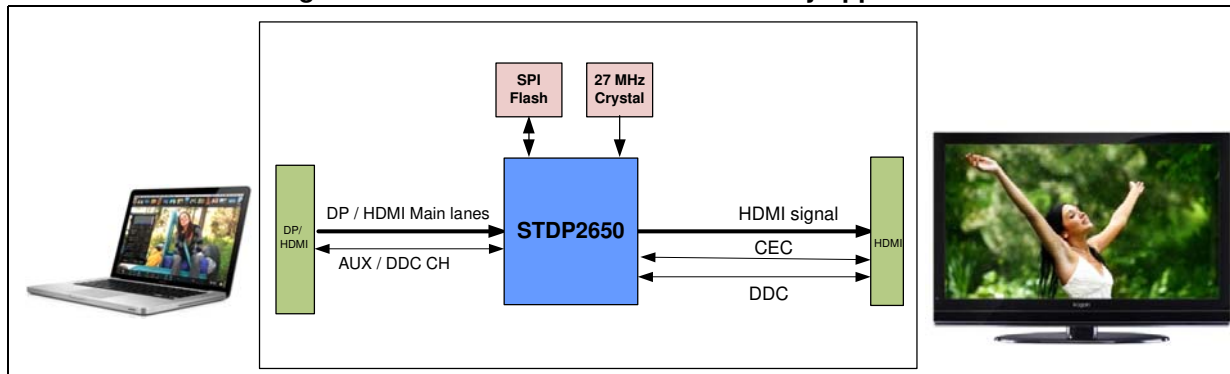
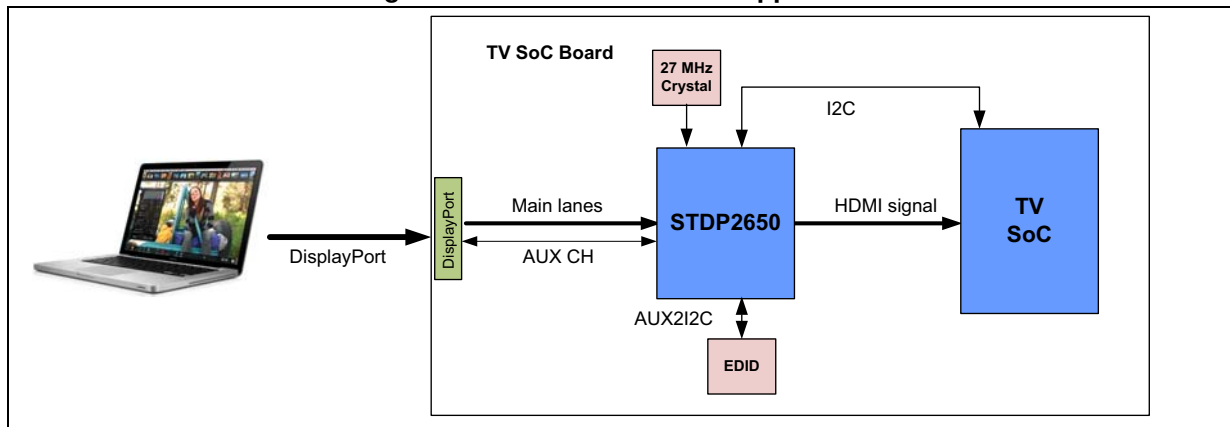

Figure 2. STDP2650 inside TV application



3. Feature attributes

3.1 Input interface

- DisplayPort dual-mode standard Ver. 1.2a compliant
- DP main link configuration (SST format only, no MST format support)
 - HBR2/HBR/RBR link rate
 - 1, 2, or 4 lanes
- AUX CH: 1 Mbps Manchester transaction format
- HPD: IRQ_HPD assertion
- Video: EDID 1.4 and CEA861 video timing and formats from 24 to 48 bits/pixel in RGB or YCC422 or YcC444 calorimetry
- Audio: DisplayPort 1.2a standard info frame packets and IEC60958/61937 type audio stream packets ranging from 16 to 24 bits/sample, 32 to 192 kHz sample rates
- Operates as DC coupled HDMI 1.4 compliant input up to 2.97 Gbps/data pair max

3.2 Output interface

- HDMI standard Ver. 1.4 compliant
- Link rate: 2.97 Gbps/data pair max
- Video: HDMI 1.4 primary and secondary timing formats, as well as CEA861 timing formats with pixel repetition for lower resolutions
- Deep color encoding up to 48 bits/pixel in 444 and 422; encoding in 601, 709, and IEC61966 color spaces
- Audio: IEC60958 L-PCM and IEC61937 streams up to 24 bits/sample from 32 kHz to 192 kHz
- DDC master port
- HPD monitoring
- HDMI RX 3.3 V termination monitoring

3.3 Operating modes

- DP 1.2 to HDMI 1.4 protocol converter
- HDMI 1.4 to HDMI 1.4 re-timer

3.4 Deep color support

- RGB/YCC (4:4:4) – 16-bit color
- YCC (4:2:2) – 16-bit color
- Color space conversion – YUV to RGB and RGB to YUV

3.5 Supported video timings

- 4096 x 2160 (4K x 2K) 24 Hz/30 Hz: 24 bits/pixel
- 1920 x 1080 (FHD) 120 Hz: 24 bits/pixel
- 2560 x 1600 (WQXGA) 60 Hz: 24 bits/pixel
- Up to 1920 x 1080 (FHD) 60 Hz, 48, 36, 30 bits/pixel
- All compatible 3D formats defined in DP 1.2a and HDMI 1.4 specifications
- All standard CEA861 timing formats

3.6 Supported audio timings

- All audio formats as specified in DP 1.2a and HDMI 1.4 specifications
- SPDIF: 2-Ch LPCM, AC3, DTS, bit depth up to 24 bits, sample rate up to 192 kHz

3.7 Control channel interfaces

- AUX CH, I2C host interface, SPI (optional), and UART (UART for test/debug purposes only)

3.8 HDCP 1.3 support

- Key sets for DPRX and HDMI TX integrated in one-time programmable ROM (OTP)
- Standalone HDCP repeater capability
- Supports eDP display authentication option ASSR (Alternate Scrambler Seed Reset)

3.9 Package

- 81 BGA (8 x 8 mm), 0.8 ball pitch

3.10 Power supply voltages

- 3.3 V I/O; 1.2 V core

3.11 ESD

- 2 KV HBM, 500 V CDM

4. BGA footprint and pin lists

4.1 Ball grid array diagram

The ball grid array (BGA) diagrams give the allocation of pins to the package, shown from the top looking down using the PCB footprint.

Some signal names in BGA diagrams have been abbreviated. Refer to [Table 2: Pin list on page 14](#) for full signal names sorted by pin number.

Table 1. Key to BGA diagrams

Function	Type	Key
AVDD12_RX	VCC/VDD	
AVDD33_RX	VCC/VDD	
AVDD33_RCOSC	VCC/VDD	
AVDD12_TX	VCC/VDD	
AVDD33_TX	VCC/VDD	
DVDD12	VCC/VDD	
DVDD33	VCC/VDD	
System ground	VSS/GND	
No connect/Do not connect	NC/DNC	

The STDP2650 is available in a 81-pin BGA package.

Figure 3. STDP2650 BGA diagram

	01	02	03	04	05	06	07	08	09	
A	CPHY_RX3_N	CPHY_RX3_P	CPHY_RX2_N	CPHY_RX2_P	CPHY_RX1_N	CPHY_RX1_P	CPHY_RX0_N	CPHY_RX0_P	CPHY_RXAUXP	A
B	SPI_DI	SPI_CSN	AVDD12_RX	AVDD12_RX	AVDD33_RX	CPHY_RX_REXT	AVDD12_PLL	TEST_MISN	CPHY_RXAUXN	B
C	SPI_CLK	SPI_DO	VSS	VSS	AVDD33_RX	AVDD33_RX	AVDD33_RCOSC	TESTMODE0_CONFIG1	UART_RX	C
D	PWR_CTRL	I2C_SDA	DVDD12	VSS	VSS	VSS	DVDD12	TESTMODE1_CONFIG2	UART_TX	D
E	CHRG_CTRL	I2C_SCL	DVDD12	VSS	VSS	VSS	DVDD12	VSS	IRQ	E
F	PWR_SENSE	SPDIF	DVDD33	VSS	VSS	VSS	VSS	HPD_OUT_AUX_HPD	CEC	F
G	HPD_IN	HDMITX_DDC_SDA	DVDD33	VSS	VSS	AVDD33_TX	VSS	RESETn	XTAL	G
H		HDMITX_DDC_SCL	TX_REXT	AVDD12_TX	AVDD12_TX	AVDD12_TX	AVDD12_OSC	DVDD25_SM	TCLK	H
J		HDMI_TXCKN	HDMI_TXCKP	HDMI_TX0N	HDMI_TX0P	HDMI_TX1N	HDMI_TX1P	HDMI_TX2N	HDMI_TX2P	J
	01	02	03	04	05	06	07	08	09	

4.2 Full pin list sorted by pin number

Table 2. Pin list

Pin number	Net name
A1	CPHY_RX3_N
A2	CPHY_RX3_P
A3	CPHY_RX2_N
A4	CPHY_RX2_P
A5	CPHY_RX1_N
A6	CPHY_RX1_P
A7	CPHY_RX0_N
A8	CPHY_RX0_P
A9	CPHY_RXAUXP
B1	SPI_DI
B2	SPI_CSN
B3, B4	AVDD12_RX
B5	AVDD33_RX
B6	CPHY_RX_REXT
B7	AVDD12_PLL
B8	TEST_MISN
B9	CPHY_RXAUXN
C1	SPI_CLK
C2	SPI_DO
C3, C4	VSS
C5, C6	AVDD33_RX
C7	AVDD33_RCOSC
C8	CONFIG1
C9	UART_RX
D1	PWR_CTRL
D2	I2C_SDA
D3	DVDD12
D4, D5, D6	VSS
D7	DVDD12
D8	CONFIG2
D9	UART_TX
E1	CHRG_CTRL
E2	I2C_SCL

Table 2. Pin list (continued)

Pin number	Net name
E3	DVDD12
E4, E5, E6	VSS
E7	DVDD12
E8	VSS
E9	IRQ
F1	PWR_SENSE
F2	SPDIF
F3	DVDD33
F4, F5, F6, F7	VSS
F8	HPD_OUT_AUX_HPD
F9	CEC
G1	HPD_IN
G2	HDMI_DDC_SDA
G3	DVDD33
G4, G5	VSS
G6	AVDD33_TX
G7	VSS
G8	RESETn
G9	XTAL
H1	DNC
H2	HDMI_DDC_SCL
H3	TX_REXT
H4, H5, H6	AVDD12_TX
H7	AVDD12_OSC
H8	DVDD25_SM
H9	TCLK
J1	DNC
J2	HDMI_TXCKN
J3	HDMI_TXCKP
J4	HDMI_TX0N
J5	HDMI_TX0P
J6	HDMI_TX1N
J7	HDMI_TX1P
J8	HDMI_TX2N
J9	HDMI_TX2P

5. Connections

5.1 Pin list

I/O Legend: I = Input; O = Output; P = Power; G = Ground; IO = Bi-direction; AI = Analog input; AO = Analog output; AIO = Analog I/O; TRI = Tristate; TOL = Tolerance; PD = Internal 50K pulldown; PU = Internal 50K pull-up; OPENDR = Open drain output

Note: Some pins can have multiple functionalities, which are configured under register control. The alternate functionality for each pin is listed in the Description column.

Table 3. DisplayPort receiver pins

Pin	Assignment	I/O	Description	Reset state
B9	CPHY_RXAUXN	AIO, 3V3 tol	AC couple 0.1uF. Use 20 ohm damping resistor in series and 1M ohm pull down to GND before cap.	Tristate
A9	CPHY_RXAUXP	AIO, 3V3 tol	AC couple 0.1uF. Use 20 ohm damping resistor in series and 1M ohm pull up to 3.3 V before cap.	Tristate
B6	CPHY_RX_REXT	AI, 3V3 tol	Combo receiver external 249 ohm resistor to VDD33.	NA
A8	CPHY_RX0_P	AI, 3V3 tol	DP RX0_P/ HDMI_RXCN For DP input: Use AC couple 0.1 uF. Use 100 K ohm pull down to GND between the connector and AC-coupling cap. For HDMI input: Direct connect to HDMI connector.	Input
A7	CPHY_RX0_N	AI, 3V3 tol	DP RX0_N/ HDMI_RXCP For DP input: use AC couple 0.1 uF. Use 100 K ohm pull down to GND between the connector and AC-coupling cap. For HDMI input: Direct connect to HDMI connector.	Input
A6	CPHY_RX1_P	AI, 3V3 tol	DP RX0_P/ HDMI_RX0N For DP input: use AC couple 0.1 uF. Use 100 K ohm pull down to GND between the connector and AC-coupling cap. For HDMI input: Direct connect to HDMI connector.	Input
A5	CPHY_RX1_N	AI, 3V3 tol	DP RX0_P/ HDMI_RX0P For DP input: use AC couple 0.1 uF. Use 100 K ohm pull down to GND between the connector and AC-coupling cap. For HDMI input: Direct connect to HDMI connector.	Input
A4	CPHY_RX2_P	AI, 3V3 tol	DP RX0_P/ HDMI_RX1N For DP input: use AC couple 0.1 uF. Use 100 K ohm pull down to GND between the connector and AC-coupling cap. For HDMI input: Direct connect to HDMI connector.	Input

Table 3. DisplayPort receiver pins

Pin	Assignment	I/O	Description	Reset state
A3	CPHY_RX2_N	AI, 3V3 tol	DP RX0_P/ HDMI_RX1P For DP input: use AC couple 0.1 uF. Use 100 K ohm pull down to GND between the connector and AC-coupling cap. For HDMI input: Direct connect to HDMI connector.	Input
A2	CPHY_RX3_P	AI, 3V3 tol	DP RX0_P/ HDMI_RX2N For DP input: use AC couple 0.1 uF. Use 100 K ohm pull down to GND between the connector and AC-coupling cap. For HDMI input: Direct connect to HDMI connector.	Input
A1	CPHY_RX3_N	AI, 3V3 tol	DP RX0_P/ HDMI_RX2P For DP input: use AC couple 0.1 uF. Use 100 K ohm pull down to GND between the connector and AC-coupling cap. For HDMI input: Direct connect to HDMI connector.	Input

Table 4. System function pins

Pin	Assignment	I/O	Description	Reset state
B8	TEST_MISN	I, 3V3 tol, TRI, INT PD	Connect to GND	Input, Low
H9	TCLK	AIO, 1V2 tol	Connect to 27 MHz crystal oscillator with 22 pF to 1.2V	NA
G9	XTAL	AIO, 1V2 tol		
G8	RESETn	AIO, 3V3 tol	3K ohm resistor to 3.3V	NA
B2	SPI_CSN	IO, 3V3 tol, TRI, INT PU	To SPI chip select. Also see bootstraps.	Output, High
C2	SPI_DO	IO, 3V3 tol, TRI INT PD	To SPI data out. Also see bootstraps.	Output, Low
B1	SPI_DI	IO, 3V3 tol, TRI, INT PD	From SPI data in.	Input, Low
C1	SPI_CLK	IO, 3V3 tol, TRI, INT PD	To SPI clock. Also see bootstraps.	Output, Low

Table 5. General purpose input/output and multi-function pins

Pin	Assignment	I/O	Description	Reset state
F9	CEC	3.3V IO, 5V tol, OPENDR	To HDMI CEC pin. 27 K res to 3.3 V via low leakage current diode. Note: In HDMI-to-HDMI re-timer mode, CEC signal from downstream connector can directly connect to upstream HDMI connector.	OPENDR

Table 5. General purpose input/output and multi-function pins

Pin	Assignment	I/O	Description	Reset state
F8	HPD_OUT_AUX_HP D	IO, 3V3 tol, TRI	To the upstream HPD signal pin on the DP connector. 100 K res to GND. Note: Level shifting from 5 V to 3.3 V is needed when connecting to HDMI source.	Output
E9	IRQ	IO, 3V3 tol, TRI	GPIO/IRQ out for host interface. Also see bootstrap function.	TRI, Low
D9	UART_TX	IO, 3V3 tol, OPENDR	To debug port UART_TX/alt I2C_SDA/GPIO. FS, FT.	OPENDR
C9	UART_RX	IO, 3V3 tol, OPENDR	To debug port UART_RX/alt I2C_SCL/GPIO. Needs external 4.7 K res to 3.3 V, FS, FT	Input
F2	SPDIF	IO, 3V3 tol, TRI, PU	To external buffer for SPDIF output or use as GPIO. Also see bootstrap function.	Output, High
G1	HPD_IN	IO, 5V tol, OPENDR	From downstream HDMI connector. Needs 47 K to GND.	Input
D1	PWR_CTRL	IO, 3V3 tol, TRI	Use as GPIO	Output
E1	CHRG_CTRL	IO, 3V3 tol, TRI	Use as GPIO	Output
D2	I2C_SDA	IO, 3V3 tol, TRI	GPIO/I2C_SDA slave or master, FS, FT, 2.2 K res to 3.3 V	TRI
E2	I2C_SCL	IO, 3V3 tol, TRI	GPIO/I2C_SCL slave or master, FS, FT, 2.2 K res to 3.3 V	TRI
F1	PWR_SENSE	IO/AI, 3V3 tol, OPENDR	GPIO/power sense analog/level sensing input, FS, FT	OPENDR
G2	HDMI_DDC_SDA	IO, 5V tol, OPENDR	GPIO/HDMI DDC SDA, FS, FT. 47 K res to 5 V when connecting with HDMI sink/source	OPENDR
H2	HDMI_DDC_SCL		GPIO/HDMI DDC SCL, FS, FT. 47 K res to 5 V when connecting with HDMI sink/source	OPENDR
D8	CONFIG2	IO, 3V3 tol, TRI	GPIO, 3.3V PAD. Connect to GND when not used.	Input
C8	CONFIG1			Input

Table 6. Transmitter pins

Pin	Assignment	I/O	Description	Reset state
H3	TX_REXT	AI, 1V2 tol	Transmitter, external 249 ohm resistor to VDD12	NA
J2	HDMI_TXCKN	AO, 3V3 tol	HDMI transmitter CLOCK_N to TX connector	Output
J3	HDMI_TXCKP	AO, 3V3 tol	HDMI transmitter CLOCK_P to TX connector	Output
J4	HDMI_TX0N	AO, 3V3 tol	HDMI transmitter DATA0_N to TX connector	Output
J5	HDMI_TX0P	AO, 3V3 tol	HDMI transmitter DATA0_P to TX connector	Output
J6	HDMI_TX1N	AO, 3V3 tol	HDMI transmitter DATA1_N to TX connector	Output
J7	HDMI_TX1P	AO, 3V3 tol	HDMI transmitter DATA1_P to TX connector	Output

Table 6. Transmitter pins

Pin	Assignment	I/O	Description	Reset state
J8	HDMI_TX2N	AO, 3V3 tol	HDMI transmitter DATA2_N to TX connector	Output
J9	HDMI_TX2P	AO, 3V3 tol	HDMI transmitter DATA2_P to TX connector	Output

Note: The default DP and HDMI output signals mapping match the standard DP and HDMI connector pin mapping, However lane swapping and polarity swapping is possible through software configuration.

Table 7. System power and ground

Pin	Assignment	Description
F3, G3	DVDD33	I/O VDD, 3.3V digital supply. De-couple using 100 nF.
D3, D7, E3, E7	DVDD12	Core VDD, 1.2V digital supply. De-couple using 100 nF.
C7	AVDD33_RCOSC	3.3V RC-oscillator analog supply. De-couple using 100 nF.
B7	AVDD12_PLL	1.2V analog PLL supply. De-couple using 10 uF and 100 nF.
B3, B4	AVDD12_RX	1.2V analog receiver supply. EMI filter rail and de-couple using 10 uF and 100 nF.
B5, C5, C6	AVDD33_RX	3.3V analog receiver supply. EMI filter rail and de-couple using 10 uF and 100 nF.
G6	AVDD33_TX	3.3V analog transmitter supply. EMI filter rail and de-couple using 10 uF and 100 nF.
H4, H5, H6	AVDD12_TX	1.2V analog transmitter supply. EMI filter rail and de-couple using 10 uF and 100 nF.
H7	AVDD12_OSC	1.2V analog crystal oscillator supply. De-couple using 100 nF.
H8	DVDD25_SM	Decoupling point for internal 2.5V LDO supply. De-couple using 10 uF and 100 nF.
C3, C4, D4, D5, D6, E4, E5, E6, E8, F4, F5, F6, F7, G4, G5, G7	VSS	Common GND. Connect to GND plane

Table 8. Reserved pins

Pin	Assignment	Description
H1	DNC	Reserved. Do not connect
J1	DNC	

5.2 Bootstrap configuration

DC Levels on some device pins are specified during de-asserting edge of power-on reset (RESETn goes High). The levels specified below must be adhered to for normal function of the device.

Table 9. Bootstrap configuration

BS signal name	Internal PU/PD	Assignment	Function
IROM_DEBUGn_Bootstrap5	PULL UP	SPI_CSN	Reserved. SPI_CSN <i>must not</i> be Pulled Down during Power-On RESET.
XTAL_OSC_SEL_Bootstrap4	PULL UP	SPDIF_OUT	Reserved. SPDIF_OUT <i>must not</i> be Pulled Down during Power-On RESETn.
ICD_DEBUG_Bootstrap3	PULL DN	SPI_DO	Reserved. SPI_DO <i>must not</i> be Pulled Up during Power-On RESETn.
XROM_EN_Bootstrap2	PULL DN	SPI_CLK	Reserved. SPI_CLK <i>must not</i> be Pulled Up during Power-On RESETn.
RESERVED_Bootstrap1	PULL DN	IRQ	Reserved. IRQ pin <i>must not</i> be Pulled Up during Power-On RESETn.
ATE_MODE_EN_Bootstrap0	Open drain	UART_TX	Reserved. UART_TX <i>must</i> be Pulled Up during Power-On RESETn.

Note: When the pin corresponding to a specific bootstrap is left NC, it will take the value of the assigned by the internal PULLUP (Level 1) or PULLDN (Level0). The internal resistor used is around 50k ohm. To select a non-default value on a bootstrap, an external PULLUP or PULLDN resistor tied to the opposite direction that overcomes the internal PULLUP or PULLDN needs to be used.

6. Package specifications

Package type: 81 BGA (8 x 8 mm / ball pitch 0.8 mm)

6.1 Package drawing

Figure 4. Package drawing

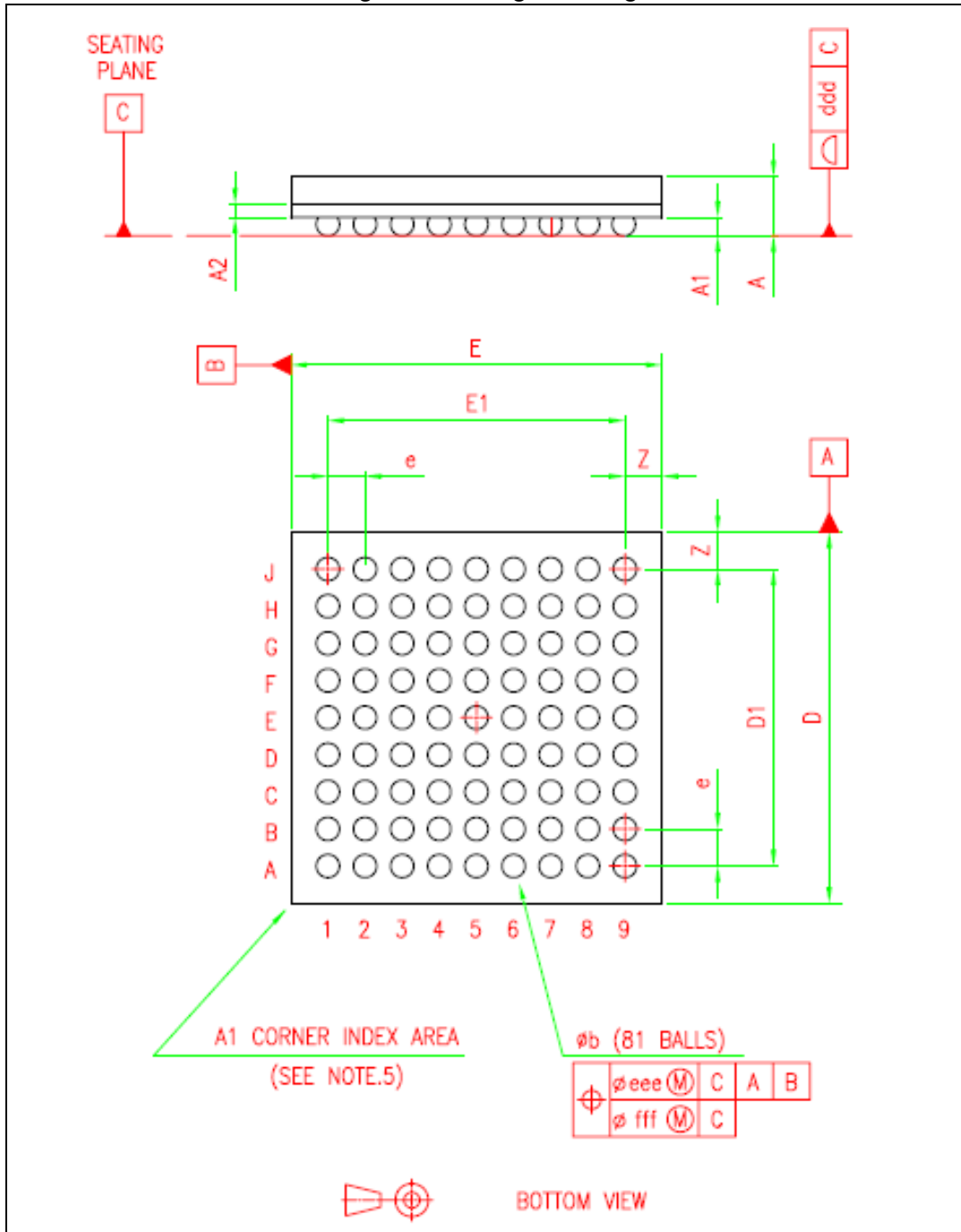

6.2 BGA8X8 dimensions

Figure 5. Package dimensions

DIMENSIONS							
REF.	DATABOOK (mm)			DRAWING (mm)			NOTES
	MIN.	TYP.	MAX.	MIN.	TYP.	MAX.	
A			1.4			1.33	(1)
A1	0.27			0.35	0.40	0.45	
A2		0.28		0.24	0.28	0.32	
A4			0.60	0.57	0.585	0.60	
b	0.45	0.50	0.55	0.45	0.50	0.55	(2)
D	7.85	8.00	8.15	7.90	8.00	8.10	
D1		6.40			6.40		
E	7.85	8.00	8.15	7.90	8.00	8.10	
E1		6.40			6.40		
e		0.80			0.80		
Z		0.80			0.80		
ddd			0.12			0.12	
eee			0.15			0.15	(3)
fff			0.08			0.08	(4)

Note:

(1) – LFBGA stands for Low profile Fine pitch Ball Grid Array.

– Low profile: $1.20\text{mm} < A = 1.70\text{mm}$ / Fine pitch: $e < 1.00\text{mm}$.

– The total profile height (Dim A) is measured from the seating plane “C” to the top of the component.

– The maximum total package height is calculated by the RSS method (Root Sum Square):

$A_{Max} = A1_{Typ} + A2_{Typ} + A4_{Typ} + \sqrt{A1^2 + A2^2 + A4^2}$ tolerance values).

(2) – The typical ball diameter before mounting is 0.50mm.

(3) – The tolerance of position that controls the location of the pattern of balls with respect to datums A and B. For each ball there is a cylindrical tolerance zone eee perpendicular to datum C and located on true position with respect to datums A and B as defined by e. The axis perpendicular to datum C of each ball must lie within this tolerance zone.

4) – The tolerance of position that controls the location of the balls within the matrix with respect to each other. For each ball there is a cylindrical tolerance zone fff perpendicular to datum C and located on true position as defined by e. The axis perpendicular to datum C of each ball must lie within this tolerance zone. Each tolerance zone fff in the array is contained entirely in the respective zone eee above. The axis of each ball must lie simultaneously in both tolerance zones.

(5) – The terminal A1 corner must be identified on the top surface by using a corner

chamfer, ink or metalized markings, or other feature of package body or integral heat slug.

– A distinguishing feature is allowable on the bottom surface of the package to identify the terminal A1 corner. Exact shape of each corner is optional.

6.3 Marking field template and descriptors

The STDP2650 marking template is shown below.

Figure 6. Marking template

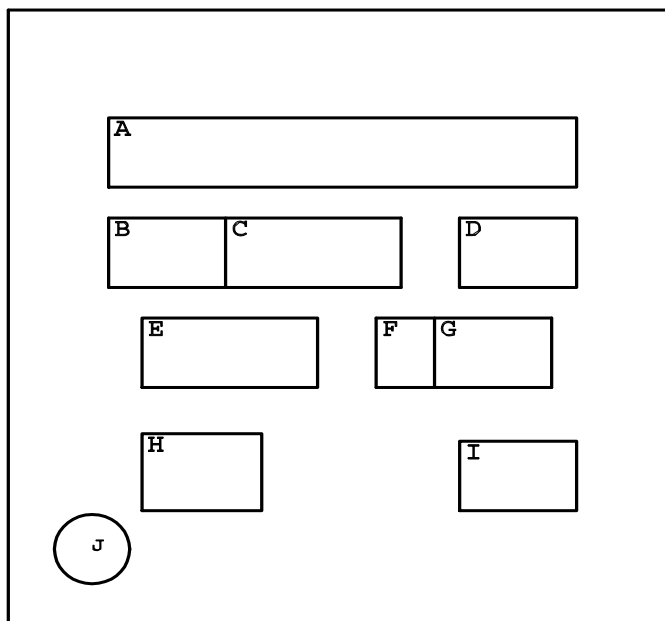

Field descriptors are shown below.

Table 10. Field descriptors

Field	Description	Marking
A	Product code	STDP2650
B	2-character assembly plant code	99
C	3-character BE sequence code	"XYZ"
D	2-character diffusion plant code	VQ
E	3-character country of origin code	MYS
F	1-digit assembly year	"Y"
G	2-digit assembly week	"WW"
H	Standard MegaChips logo	M
I	2-character version code	AD
J	Ball A1 identifier	a DOT

6.4 Classification reflow profile

Please refer to the DisplayPort Application Note: Classification reflow profile for SMD devices (C0353-APN-06) for reflow diagram and details.

7. Electrical specifications

7.1 Absolute maximum ratings

Applied conditions greater than those listed under “Absolute maximum ratings” may cause permanent damage to the device. The device should never exceed absolute maximum conditions since it may affect device reliability.

Table 11. Absolute maximum ratings

Parameter	Symbol	Min	Typ	Max	Units
3.3 V supply voltages ^(1,2)	V _{VDD_3.3}	-0.3	3.3	3.63	V
1.2 V supply voltages ^(1,2)	V _{VDD_1.2}	-0.3	1.2	1.26	V
Input voltage for tolerance for 5V I/O pin ^(1,2)	V _{IN5Vtol}	-0.3	-	5.5	V
Input voltage tolerance for 3.3V I/O pin ^(1,2)	V _{IN3V3tol}	-0.3	-	3.63	V
ESD - Human Body Model (HBM)	V _{ESD}	-	-	±2	kV
ESD - Charged Device Model (CDM)	V _{ESD}	-	-	±500	V
Latch-up	I _{LA}	-	-	±200	mA
Ambient operating temperature	T _A	0	-	70	°C
Storage temperature	T _{STG}	-40	-	125	°C
Operating junction temperature	T _J	0	70	125	°C
Thermal resistance (Junction to Ambient)	θ _{JA}	-	52.4	-	°C/W
Thermal resistance (Junction to Case)	θ _{JC}	-	24.4	-	°C/W
Peak IR reflow soldering temperature	T _{SOL}	-	-	260	°C

Note (1): All voltages are measured with respect to GND.

Note (2): Absolute maximum voltage ranges are for transient voltage excursions.

7.2 DC characteristics

Table 12. DC characteristics

Parameter	Symbol	Min	Typ	Max ⁽¹⁾	Units
Power					
3.3 V supply voltages (analog and digital)	V _{VDD_3.3}	3.14	3.3	3.47	V
1.2 V supply voltages (analog and digital)	V _{VDD_1.2}	1.14	1.2	1.26	V
Power					
Measurement conditions: 1920 x 1080 / 120 Hz test pattern: ON-OFF dot.			462		mW
Sleep mode			21		mW

Table 12. DC characteristics

Parameter	Symbol	Min	Typ	Max ⁽¹⁾	Units
Supply current					
Measurement conditions: 1920 x 1080 / 120 Hz test pattern: ON-OFF dot Moire VDD (analog and digital power) = 3.3 V VDDA (analog and digital power) = 1.2 V In all configuration, 8 bits input is used.		-	47.3 254.5	-	mA
Inputs					
High voltage	V _{IH}	2.0	-	-	V
Low voltage	V _{IL}	-	-	0.8	V
Input hysteresis voltage	V _{HYST}	300	-	-	mV
High current (V _{IN} = 3.3V)	I _{IH}	-	-	±10	μA
Low current (V _{IN} = 0 V)	I _{IL}	-	-	±10	μA
Capacitance (V _{IN} = 2.4 V)	C _{IN}	-	-	5	pF
Outputs					
High voltage (I _{OH} = 8mA)	V _{OH}	2.4	-	-	V
Low voltage (I _{OL} = -8 mA)	V _{OL}	-	-	0.4	V
Tri-state leakage current	I _{OZ}	-	-	±10	μA

Note: The values in the Max column represent absolute maximum current consumption under high voltage (+5%) and nominal temperature. These values are measured in an environment that includes some discreet components. Other conditions include: a) Power measurement values are to be used for regulator sizing only, and not directly for package thermal calculations. b) IC performance is only guaranteed when operating within the "DC Characteristics". c) All inputs are 3.3V tolerant.

7.3 AC characteristics

Table 13. Maximum speed of operation

Clock domain	Max speed of operation
Reference Input Clock (TCLK)	27 MHz
Reference Internal Clock (RCLK)	324 MHz
On-Chip Microcontroller Clock (OCLK)	100 MHz
SPDIF audio output	192 kHz
2-Wire Serial Slave (SLAVE_SCL)	400 kHz
2-Wire DDC2bi Slave (VGAX_SCL)	400 kHz
2-Wire Serial Master (MSTRx_SCL)	400 kHz