



Chipsmall Limited consists of a professional team with an average of over 10 year of expertise in the distribution of electronic components. Based in Hongkong, we have already established firm and mutual-benefit business relationships with customers from,Europe,America and south Asia,supplying obsolete and hard-to-find components to meet their specific needs.

With the principle of "Quality Parts,Customers Priority,Honest Operation,and Considerate Service",our business mainly focus on the distribution of electronic components. Line cards we deal with include Microchip,ALPS,ROHM,Xilinx,Pulse,ON,Everlight and Freescale. Main products comprise IC,Modules,Potentiometer,IC Socket,Relay,Connector.Our parts cover such applications as commercial,industrial, and automotives areas.

We are looking forward to setting up business relationship with you and hope to provide you with the best service and solution. Let us make a better world for our industry!



## Contact us

Tel: +86-755-8981 8866 Fax: +86-755-8427 6832

Email & Skype: info@chipsmall.com Web: www.chipsmall.com

Address: A1208, Overseas Decoration Building, #122 Zhenhua RD., Futian, Shenzhen, China



## STDP4020, STDP4010 DisplayPort receiver

### Datasheet

Rev A



#### **MegaChips' Proprietary Information**

MegaChips reserves the right to make any change herein at any time without prior notice. MegaChips does not assume any responsibility or liability arising out of application or use of any product or service described herein except as explicitly agreed upon.

### Features

- Enhanced DisplayPort® (DP) receiver
  - DP 1.1a compliant
  - Embedded DisplayPort (eDP) compliant
  - 1, 2, or 4 lanes
- Higher bandwidth “Turbo mode” (3.24 Gbps per lane), supports:
  - 1920 x 1080 (FHD) 120 Hz/10-bit color video standard timings and 7.1 Ch audio
  - 2560 x 1600 (WQXGA), 2560 x 2048 (QSXGA) 60 Hz/10-bit color graphics and 7.1 Ch audio
- Interface compatibility with wide range of display controller ICs
  - LVTTTL (60 wide) and LVDS (quad bus) video interface
  - 8-Ch I2S and SPDIF audio interface
- Robust AUX channel
  - Link service, maintenance
  - I2C-over-AUX (MCCS, DDC)
  - IR, full duplex UART protocol
- Configurable through I2C host interface
- Supports HDCP 1.3 with on-chip keys

- HDCP repeater capability
  - Acts as upstream receiver
- AUX to I2C bridge for EDID, MCCS pass through
- Spread spectrum on DisplayPort, LVDS, and TTL interfaces for EMI reduction
- Supports deep color and color format conversion
  - RGB/YUV (4:4:4) – 10-bit color
  - YUV (4:2:2/4:2:0) – 12-bit color
  - RGB (4:4:4) to YUV (4:4:4) conversion and vice-versa
- Supports HBR/“Turbo” speed over HBR/RBR-rated long cables (15 m and more)
- Package
  - 164 LFBGA (12 x 12 mm / 0.8 mm)
- Power supply voltages
  - 3.3 V I/O; 1.2 V core

### Applications

- Digital TV, LCD monitor, mobile display, projector, etc

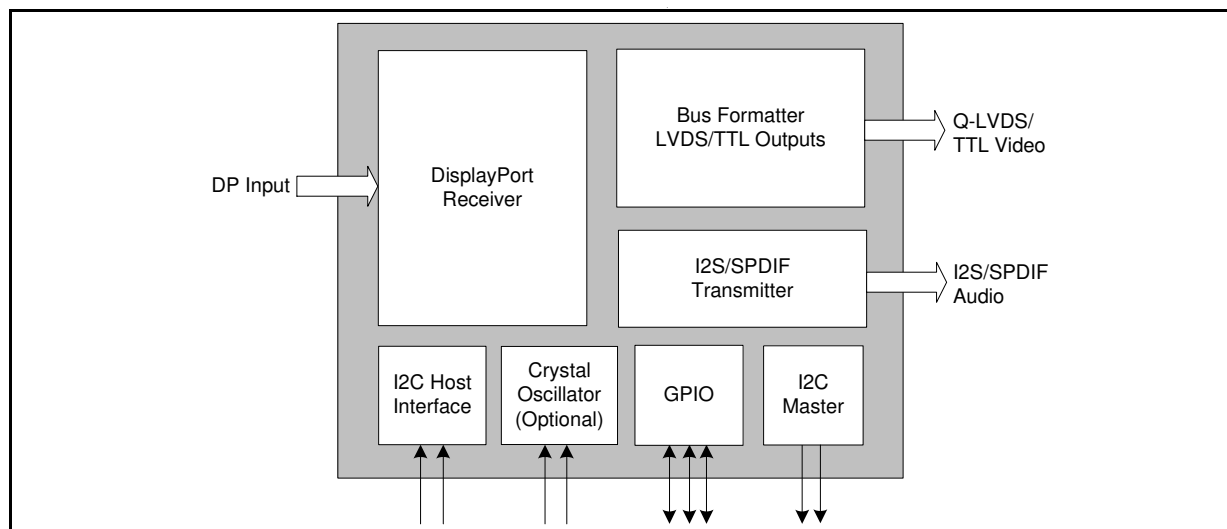

---

## Contents

1.	Description .....	6
2.	Application overview .....	8
3.	Feature attributes .....	9
4.	BGA footprint and pin lists .....	10
4.1	Ball grid array diagram .....	10
4.2	Full pin list sorted by pin number .....	12
5.	Connections .....	17
5.1	Pin list .....	17
5.2	Bootstrap configuration .....	25
5.3	General purpose input/output (GPIO) pins .....	27
6.	Package .....	28
6.1	Marking field template and descriptors .....	29
7.	Electrical specification .....	30
7.1	Absolute maximum ratings .....	30
7.2	Maximum speed of operation .....	30
7.3	DC characteristics .....	32
7.4	AC characteristics .....	33
7.4.1	DisplayPort receiver .....	33
7.4.2	Digital video output port .....	35
7.4.3	LVDS transmitter .....	36
7.4.4	I2C interface timing .....	37
7.4.5	SPI interface timing .....	39
8.	Ordering information .....	41
9.	Revision history .....	42

---

## List of Tables

Table 1.	Key to BGA diagrams . . . . .	10
Table 2.	Pin list . . . . .	12
Table 3.	DisplayPort receiver pins . . . . .	17
Table 4.	Reference clocks . . . . .	18
Table 5.	Digital video outputs - LVDS & TTL (suggested mapping) . . . . .	18
Table 7.	Multi-function and system interface connections . . . . .	22
Table 6.	Multi-function - digital audio output, general purpose input/output, bootstrap pins. . . . .	22
Table 8.	No connects . . . . .	24
Table 9.	System power and ground . . . . .	25
Table 10.	Bootstrap configuration . . . . .	26
Table 11.	Software implemented bootstrap configuration . . . . .	26
Table 12.	Field descriptors . . . . .	29
Table 13.	Absolute maximum ratings . . . . .	30
Table 14.	DC characteristics . . . . .	32
Table 15.	DisplayPort receiver characteristics . . . . .	33
Table 16.	Digital video output port timing . . . . .	35
Table 17.	LVDS TX1 even channels . . . . .	36
Table 18.	LVDS TX1 odd channels . . . . .	36
Table 19.	LVDS TX2 even channels . . . . .	37
Table 20.	LVDS TX2 odd channels . . . . .	37
Table 21.	I2C interface timing . . . . .	37
Table 22.	SPI interface timing, VDD = 3.3V . . . . .	39
Table 23.	Order codes . . . . .	41
Table 24.	Document revision history . . . . .	42

---

## List of Figures

Figure 1.	System interface block diagram . . . . .	8
Figure 2.	Pin diagram . . . . .	11
Figure 3.	Package specification . . . . .	28
Figure 4.	Marking template . . . . .	29
Figure 5.	Display output port timing . . . . .	35
Figure 6.	LVDS transmitter switching characteristics . . . . .	36
Figure 7.	I2C Timing . . . . .	38
Figure 8.	SPI output or serial interface SPI ROM input timing . . . . .	39
Figure 9.	SPI input or serial interface SPI ROM output timing . . . . .	40

## 1. Description

The STDP4020 is a DisplayPort receiver IC for the reception of secure, high-bandwidth uncompressed digital audio-video signals targeted for applications such as DTV, LCD monitor, projector, and other types of display systems. STDP4020 is a VESA DP 1.1a and eDP compliant device, implementing a single link DisplayPort input port comprising four main lanes, auxiliary channel, and HPD. In addition to the standard HBR (2.7 Gbps) and RBR (1.62 Gbps) speeds, this device supports turbo speed of 3.24 Gbps per lane with a total link bandwidth of 12.96 Gbps. The higher bandwidth provides unique benefits to users over other commercial DP receivers for embedded applications by offering additional margin to support higher color depth, resolution, and refresh rate. For example, STDP4020 supports FHD non-reduced blanking video (1080p 30-bit color per pixel) at 120 Hz, plus 7.1 Ch audio for two-box TV applications. The advanced equalizer built in this device offers guaranteed performance over long reach cables. The auxiliary channel in STDP4020 acts as a bidirectional communication link, supporting application-specific protocols such as MCCS, DDC, UART, IR, as well as the dedicated DisplayPort link training and device management functions.

The STDP4020 supports RGB and YUV video color formats with color depth of 12 (YUV 4:2:2 only), 10, and 8 bits. This device offers LVDS and LVTTTL output interfaces configurable to map a wide range of display controller products. The Quad LVDS interface supports video signals up to 400 MHz pixel rate with flexible channel and lane swapping options. The 60-bit LVTTTL output ports can be mapped to transfer video data either in two pixels per clock or single pixel per clock up to 330 MHz pixel rate, which opens up possibilities for 3D applications. The STDP4020 also supports both compressed and uncompressed audio formats. The extracted audio signal is transferred on a digital audio output bus. This device comprises four I2S audio output, supporting up to 8 channel LPCM audio and a single wire S/PDIF output for encoded audio. The STDP4020 features the HDCP 1.3 content protection scheme with an embedded key option for secure reception of digital audio-video content. In addition, it also supports the HDCP repeater function and, thus acts as an upstream receiver suitable for two-box TV and HDMI/DVI converter applications.

The STDP4020 is configurable from an external host controller through I2C host interface. This IC also includes general-purpose inputs/outputs for controlling system components. The STDP4020 features a color space converter (RGB to YUV and YUV to RGB) for flexible interface with external video processing devices.

STDP4020 family product includes the following part numbers:

Part number	Video input	Video output	Max video resolution
STDP4020	4 lanes DisplayPort	4 Ch LVDS/60 LVTTTL	WQXGA/FHD 120 Hz
STDP4010	2 lanes DisplayPort	2 Ch LVDS/30 LVTTTL	WUXGA/FHD 60 Hz



## 2. Application overview

The STDP4020 is designed as a DisplayPort front-end capture device for display applications. Typical display design has a display controller (scaler) that acts as system master (host). The host controller configures STDP4020 through a 2-wire host interface. The host and STDP4020 also use interrupt mechanism whenever the slave needs attention. The STDP4020 may require an external SPI Flash to store firmware for supporting custom specific applications. The audio and video output from STDP4020 can directly interface to the host display controller for further processing. The AUX I2C bypass channel handles the I2C traffic between STDP4020 and host controller, as shown in the figure below.

**Figure 1. System interface block diagram**

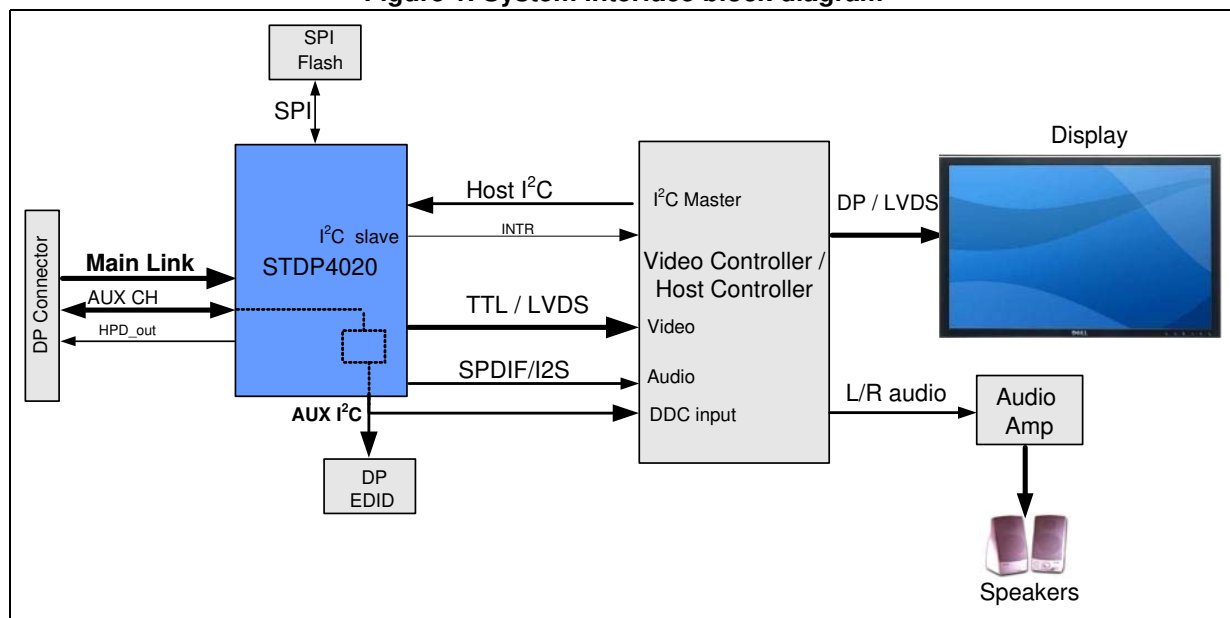

### 3. Feature attributes

- Enhanced DisplayPort (DP) receiver compliant with DP1.1a and embedded (eDP) specification
- Supports higher bandwidth mode called “Turbo mode” (3.24 Gbps per lane) for embedded applications. For example, supports FHD 120 Hz-10/12-bit video or QSXGA (2560 x 2048) 60 Hz/10-bit color graphics and 7.1 Ch audio
- Interface compatibility with wide range of display products. Supports LVTTTL (60 wide) and quad LVDS video interface
- Supports I2S 8 Ch and SPDIF audio output interface compliant with IEC60958 and IEC61937 audio formats.
- Robust AUX channel for Link service, maintenance and supports I2C over AUX, MCCS, DDC, IR and full duplex UART protocol
- Supports HDCP 1.3 with on-chip key storage
- Acts HDCP repeater for an upstream receiver
- Supports AUX to I2C bridge for EDID, MCCS pass through
- Spread spectrum on DisplayPort, LVDS and TTL interfaces for EMI reduction
- Supports deep color and color format conversion: RGB (4:4:4) to YUV (4:4:4) and vice-versa
- Supports TTL up to 330 MHz pixel clock, which allows 3D video applications
- Supports HBR/“Turbo” speed over HBR/RBR rated long cables (15 m and more)
- Configurable through I2C host interface
- Package: 164 LFBGA (12 x 12 mm / 0.8 mm)
- Power supply voltages: 3.3 V I/O; 1.2 V core















## 4. BGA footprint and pin lists

### 4.1 Ball grid array diagram

The ball grid array (BGA) diagrams give the allocation of pins to the package, shown from the top looking down using the PCB footprint.

Some signal names in BGA diagrams have been abbreviated. Refer to [Table 2: Pin list on page 12](#) for full signal names sorted by pin number.

**Table 1. Key to BGA diagrams**

Function	Type	Key
DisplayPort input	SIG	
Reference clocks	SIG	
System controls	SIG	
Multi-function and system interface connections	SIG	
I2S/SPDIF audio output	SIG	
LVDS/TTL Output_Even-0	SIG	
LVDS/TTL Output_Even-1	SIG	
LVDS/TTL Output_Odd-0	SIG	
LVDS/TTL Output_Odd-1	SIG	
Analog power	VCC/VDD	
Analog ground	VSS/GND	
System power	VCC/VDD	
System ground	VSS/GND	
No connect/Do not connect	NC/DNC	
No ball		

The STDP4020 is available in a 164-pin LFBGA package.

Figure 2. Pin diagram

	1	2	3	4	5	6	7	8	9	10	11	12	13	14	
<b>A</b>	UART_TX/BOOT6/GPIO_13	XTAL	TCLK				DPRX_ML_L1P	DPRX_ML_L0P				AUX_UART_RX/GPIO_24	NC4	PVSS3	<b>A</b>
<b>B</b>	I2S_0/BOOT2/GPIO_8	VSS_RPL_L	VDD_RPL_L	NC5		DPRX_ML_L2P	DPRX_ML_L1N	DPRX_ML_L0N	DPRX_AU_XN		DPRX_VD_DA_1V2	AUX_UART_TX/BOOT7/GPIO_23	I2C_SCL/GPIO_21	AUX_I2C_SDA/GPIO_16	<b>B</b>
<b>C</b>	CLK_OUT/GPIO_5	I2S_BCLK/BOOT1/GPIO_7	GPIO_1	PVSS3	DPRX_ML_L3P	DPRX_ML_L2N	DPRX_VD_DA_1V2	DPRX_VD_DA_1V2	DPRX_AU_XP	DPRX_RE_XT	NC3	PVDD1	AUX_I2C_SCL/GPIO_15	PVSS3	<b>C</b>
<b>D</b>		I2S_MCLK/GPIO_4	I2S_WCLK/BOOT0/GPIO_6	VBUFC_RPLL	DPRX_ML_L3N	VDDA_3V3	DPRX_VS_SA	DPRX_VS_SA	DPRX_VD_DA_1V2	DPRX_HP_D_OUT/GPIO_26	I2C_SDA/GPIO_22	IRQ/GPIO_25	SPI_DI/GPIO_19		<b>D</b>
<b>E</b>			I2S_3/BOOT5/GPIO_11	UART_RX/GPIO_14	RESETn	GPIO_0	PVDD1	PVDD1	DPRX_VS_SA	DPRX_VS_SA	SPI_DO/GPIO_20	SPI_CLK/GPIO_18		<b>E</b>	
<b>F</b>		AVSS_OUT_LVTX	TESTMODE0	I2S_2/BOOT4/GPIO_10	PVDD22	PVSS3	PVSS3	PVSS3	PVSS3	PVDD21	I2C_MST_SDA/GPIO_3	SPI_CSn/GPIO_17	AVSS_OUT_LVTX	<b>F</b>	
<b>G</b>	E1_LVTX_CH4P	E1_LVTX_CH4N	TESTMODE1	IR_IN/GPIO_12	I2S_1/BOOT3/GPIO_9	PVSS3	PVSS3	PVSS3	PVSS3	I2C_MST_SCL/GPIO_2	NC1	NC2	O1_LVTX_CH0P	O1_LVTX_CH0N	<b>G</b>
<b>H</b>	E1_LVTX_CH3P	E1_LVTX_CH3N	AVDD_OUT_LVTX_3	E1_LVTX_CH5N	AVSS_OUT_LVTX	PVSS3	PVSS3	PVSS3	PVSS3	AVSS_OUT_LVTX	O1_LVTX_CH5N	AVDD_OUT_LVTX_3	O1_LVTX_CH1P	O1_LVTX_CH1N	<b>H</b>
<b>J</b>		E1_LVTX_CLKP	E1_LVTX_CLKN	E1_LVTX_CH6P	E1_LVTX_CH5P	PVSS3	PVSS3	PVSS3	PVSS3	O1_LVTX_CH5P	O1_LVTX_CH6N	O1_LVTX_CH2P	O1_LVTX_CH2N	<b>J</b>	
<b>K</b>			E1_LVTX_CH2P	E1_LVTX_CH2N	E1_LVTX_CH6N	PVDD1	AVSS_LV_TX	AVSS_OUT_LV_TX	PVDD1	O1_LVTX_CH6P	O1_LVTX_CLKN	O1_LVTX_CLKP		<b>K</b>	
<b>L</b>		E1_LVTX_CH1P	E1_LVTX_CH1N	E0_LVTX_CH6N	E0_LVTX_CH2N	E0_LVTX_CH5N	AVDD_LV_TX_33	AVDD_OUT_LV_TX_3	O0_LVTX_CH5N	O0_LVTX_CLKN	O0_LVTX_CH6P	O1_LVTX_CH3P	O1_LVTX_CH3N	<b>L</b>	
<b>M</b>	E1_LVTX_CH0P	E1_LVTX_CH0N	E0_LVTX_CH6P	E0_LVTX_CLKN	E0_LVTX_CH2P	E0_LVTX_CH1N	E0_LVTX_CH5P	O0_LVTX_CH5P	O0_LVTX_CH3N	O0_LVTX_CLKP	O0_LVTX_CH2N	O0_LVTX_CH6N	O1_LVTX_CH4P	O1_LVTX_CH4N	<b>M</b>
<b>N</b>	AVDD_OUT_LV_TX_33	E0_LVTX_CH4N	E0_LVTX_CH3N	E0_LVTX_CLKP		E0_LVTX_CH1P	E0_LVTX_CH0N	O0_LVTX_CH4N	O0_LVTX_CH3P		O0_LVTX_CH2P	O0_LVTX_CH1N	O0_LVTX_CH0N	AVDD_OUT_LV_TX_3	<b>N</b>
<b>P</b>	AVSS_OUT_LV_TX	E0_LVTX_CH4P	E0_LVTX_CH3P				E0_LVTX_CH0P	O0_LVTX_CH4P				O0_LVTX_CH1P	O0_LVTX_CH0P	AVSS_OUT_LV_TX	<b>P</b>
	1	2	3	4	5	6	7	8	9	10	11	12	13	14	

## 4.2 Full pin list sorted by pin number

Table 2. Pin list

Pin number	Net name
A1	UART_TX/BOOT[6]/GPIO_13
A2	XTAL
A3	TCLK
A7	DPRX_ML_L1P
A8	DPRX_ML_L0P
A12	AUX_UART_RX/GPIO_24
A13	NC4
A14	PVSS3
B1	I2S_0/BOOT[2]/GPIO_8
B2	VSS_RPLL
B3	VDD_RPLL
B4	NC5
B6	DPRX_ML_L2P
B7	DPRX_ML_L1N
B8	DPRX_ML_L0N
B9	DPRX_AUXN
B11	DPRX_VDDA_1V2
B12	AUX_UART_TX/BOOT[7]/GPIO_23
B13	I2C_SCL/GPIO_21
B14	AUX_I2C_SDA/GPIO_16
C1	CLK_OUT/GPIO_5
C2	I2S_BCLK/BOOT[1]/GPIO_7
C3	GPIO_1
C4	PVSS3
C5	DPRX_ML_L3P
C6	DPRX_ML_L2N
C7, C8	DPRX_VDDA_1V2
C9	DPRX_AUXP
C10	DPRX_REXT
C11	NC3
C12	PVDD1
C13	AUX_I2C_SCL/GPIO_15
C14	PVSS3

Table 2. Pin list (continued)

Pin number	Net name
D2	I2S_MCLK/GPIO_4
D3	I2S_WCLK/BOOT[0]/GPIO_6
D4	VBUFC_RPLL
D5	DPRX_ML_L3N
D6	VDDA_3V3
D7, D8	DPRX_VSSA
D9	DPRX_VDDA_1V2
D10	DPRX_HPD_OUT/GPIO_26
D11	I2C_SDA/GPIO_22
D12	IRQ/GPIO_25
D13	SPI_DI/GPIO_19
E3	I2S_3/BOOT[5]/GPIO_11
E4	UART_RX/GPIO_14
E5	RESETn
E6	GPIO_0
E7, E8	PVDD1
E9, E10	DPRX_VSSA
E11	SPI_DO/GPIO_20
E12	SPI_CLK/GPIO_18
F2	AVSS_OUT_LVTX
F3	TESTMODE0
F4	I2S_2/BOOT[4]/GPIO_10
F5	PVDD22
F6, F7, F8, F9	PVSS3
F10	PVDD21
F11	I2C_MST_SDA/GPIO_3
F12	SPI_CS <sub>n</sub> /GPIO_17
F13	AVSS_OUT_LVTX
G1	E1_LVTX_CH4P
G2	E1_LVTX_CH4N
G3	TESTMODE1
G4	IR_IN/GPIO_12
G5	I2S_1/BOOT[3]/GPIO_9
G6, G7, G8, G9	PVSS3
G10	I2C_MST_SCL/GPIO_2

Table 2. Pin list (continued)

Pin number	Net name
G11	NC1
G12	NC2
G13	O1_LVTX_CH0P
G14	O1_LVTX_CH0N
H1	E1_LVTX_CH3P
H2	E1_LVTX_CH3N
H3	AVDD_OUT_LVTX_33
H4	E1_LVTX_CH5N
H5	AVSS_OUT_LVTX
H6, H7, H8, H9	PVSS3
H10	AVSS_OUT_LVTX
H11	O1_LVTX_CH5N
H12	AVDD_OUT_LVTX_33
H13	O1_LVTX_CH1P
H14	O1_LVTX_CH1N
J2	E1_LVTX_CLKP
J3	E1_LVTX_CLKN
J4	E1_LVTX_CH6P
J5	E1_LVTX_CH5P
J6, J7, J8, J9	PVSS3
J10	O1_LVTX_CH5P
J11	O1_LVTX_CH6N
J12	O1_LVTX_CH2P
J13	O1_LVTX_CH2N
K3	E1_LVTX_CH2P
K4	E1_LVTX_CH2N
K5	E1_LVTX_CH6N
K6	PVDD1
K7	AVSS_LVTX
K8	AVSS_OUT_LVTX
K9	PVDD1
K10	O1_LVTX_CH6P
K11	O1_LVTX_CLKN
K12	O1_LVTX_CLKP
L2	E1_LVTX_CH1P

Table 2. Pin list (continued)

Pin number	Net name
L3	E1_LVTX_CH1N
L4	E0_LVTX_CH6N
L5	E0_LVTX_CH2N
L6	E0_LVTX_CH5N
L7	AVDD_LVTX_33
L8	AVDD_OUT_LVTX_33
L9	O0_LVTX_CH5N
L10	O0_LVTX_CLKN
L11	O0_LVTX_CH6P
L12	O1_LVTX_CH3P
L13	O1_LVTX_CH3N
M1	E1_LVTX_CH0P
M2	E1_LVTX_CH0N
M3	E0_LVTX_CH6P
M4	E0_LVTX_CLKN
M5	E0_LVTX_CH2P
M6	E0_LVTX_CH1N
M7	E0_LVTX_CH5P
M8	O0_LVTX_CH5P
M9	O0_LVTX_CH3N
M10	O0_LVTX_CLKP
M11	O0_LVTX_CH2N
M12	O0_LVTX_CH6N
M13	O1_LVTX_CH4P
M14	O1_LVTX_CH4N
N1	AVDD_OUT_LVTX_33
N2	E0_LVTX_CH4N
N3	E0_LVTX_CH3N
N4	E0_LVTX_CLKP
N6	E0_LVTX_CH1P
N7	E0_LVTX_CH0N
N8	O0_LVTX_CH4N
N9	O0_LVTX_CH3P
N11	O0_LVTX_CH2P
N12	O0_LVTX_CH1N



Table 2. Pin list (continued)

Pin number	Net name
N13	O0_LVTX_CH0N
N14	AVDD_OUT_LVTX_33
P1	AVSS_OUT_LVTX
P2	E0_LVTX_CH4P
P3	E0_LVTX_CH3P
P7	E0_LVTX_CH0P
P8	O0_LVTX_CH4P
P12	O0_LVTX_CH1P
P13	O0_LVTX_CH0P
P14	AVSS_OUT_LVTX

## 5. Connections

### 5.1 Pin list

I/O Legend: I = Input; O = Output; P = Power; G = Ground

*Note: Some pins can have multiple functionalities, which are configured under register control. The alternate functionality for each pin is listed in the Description column.*

**Table 3. DisplayPort receiver pins**

Pin	Assignment	I/O	Description
B8	DPRX_ML_L0N	I	DisplayPort Receiver Main Link Lane 0 Negative Analog Input
A8	DPRX_ML_L0P	I	DisplayPort Receiver Main Link Lane 0 Positive Analog Input
B7	DPRX_ML_L1N	I	DisplayPort Receiver Main Link Lane 1 Negative Analog Input
A7	DPRX_ML_L1P	I	DisplayPort Receiver Main Link Lane 1 Positive Analog Input
C6	DPRX_ML_L2N	I	DisplayPort Receiver Main Link Lane 2 Negative Analog Input
B6	DPRX_ML_L2P	I	DisplayPort Receiver Main Link Lane 2 Positive Analog Input
D5	DPRX_ML_L3N	I	DisplayPort Receiver Main Link Lane 3 Negative Analog Input
C5	DPRX_ML_L3P	I	DisplayPort Receiver Main Link Lane 3 Positive Analog Input
B9	DPRX_AUXN	I/O	DisplayPort Receiver Auxiliary Channel Negative Analog Input/Output
C9	DPRX_AUXP	I/O	DisplayPort Receiver Auxiliary Channel Positive Analog Input/Output
D10	DPRX_HPD_OUT/GPIO_26	I/O	DisplayPort Receiver Hot Plug Detect Output General Purpose Schmitt Trigger Input / Tri-state Output 26 [5 V Tolerant]
C10	DPRX_REXT	I	Termination calibration reference resistor; 240 ohm 1% resistor should be connected from this pin to 1.2 V analog power supply.

Table 4. Reference clocks

Pin	Assignment	I/O	Description
A2	XTAL	I/O	Crystal Oscillator Input. Connect to external crystal.
A3	TCLK	I/O	Reference Clock (TCLK) from a 27MHz Crystal or TTL Oscillator. Connect to external crystal or oscillator.
D4	VBUFC_RPLL	O	Analog Test Pin for Internal Clocks.

Table 5. Digital video outputs - LVDS &amp; TTL (suggested mapping)

Pin	Assignment	I/O	Description
M3	E0_LVTX_CH6P	O	Positive output of LVDS TX E0 Channel 6
			Even Green Channel Data 8
L4	E0_LVTX_CH6N	O	Negative output of LVDS TX E0 Channel 6
			Even Green Channel Data 9
M7	E0_LVTX_CH5P	O	Positive output of LVDS TX E0 Channel 5
			Even Red Channel Data 8
L6	E0_LVTX_CH5N	O	Negative output of LVDS TX E0 Channel 5
			Even Red Channel Data 9
P2	E0_LVTX_CH4P	O	Positive output of LVDS TX E0 Channel 4
			Even Blue Channel Data 0
N2	E0_LVTX_CH4N	O	Negative output of LVDS TX E0 Channel 4
			Even Blue Channel Data 1
P3	E0_LVTX_CH3P	O	Positive output of LVDS TX E0 Channel 3
			Even Blue Channel Data 4
N3	E0_LVTX_CH3N	O	Negative output of LVDS TX E0 Channel 3
			Even Blue Channel Data 5
N4	E0_LVTX_CLKP	O	Positive output of LVDS TX E0 Clock Channel
			Even Blue Channel Data 6
M4	E0_LVTX_CLKN	O	Negative output of LVDS TX E0 Clock Channel
			Even Blue Channel Data 7
M5	E0_LVTX_CH2P	O	Positive output of LVDS TX E0 Channel 2
			Even Green Channel Data 0
L5	E0_LVTX_CH2N	O	Negative output of LVDS TX E0 Channel 2
			Even Green Channel Data 1
N6	E0_LVTX_CH1P	O	Positive output of LVDS TX E0 Channel 1
			Even Green Channel Data 2

Table 5. Digital video outputs - LVDS &amp; TTL (suggested mapping)

Pin	Assignment	I/O	Description
M6	E0_LVTX_CH1N	O	Negative output of LVDS TX E0 Channel 1
			Even Green Channel Data 3
P7	E0_LVTX_CH0P	O	Positive output of LVDS TX E0 Channel 0
			Even Green Channel Data 4
N7	E0_LVTX_CH0N	O	Negative output of LVDS TX E0 Channel 0
			Even Green Channel Data 5
J4	E1_LVTX_CH6P	O	Positive output of LVDS TX E1 Channel 6
			Odd Green Channel Data 8
K5	E1_LVTX_CH6N	O	Negative output of LVDS TX E1 Channel 6
			Odd Green Channel Data 9
J5	E1_LVTX_CH5P	O	Positive output of LVDS TX E1 Channel 5
			Odd Red Channel Data 8
H4	E1_LVTX_CH5N	O	Negative output of LVDS TX E1 Channel 5
			Odd Red Channel Data 9
G1	E1_LVTX_CH4P	O	Positive output of LVDS TX E1 Channel 4
			Odd Blue Channel Data 0
G2	E1_LVTX_CH4N	O	Negative output of LVDS TX E1 Channel 4
			Odd Blue Channel Data 1
H1	E1_LVTX_CH3P	O	Positive output of LVDS TX E1 Channel 3
			Odd Blue Channel Data 4
H2	E1_LVTX_CH3N	O	Negative output of LVDS TX E1 Channel 3
			Odd Blue Channel Data 5
J2	E1_LVTX_CLKP	O	Positive output of LVDS TX E1 Clock Channel
			Odd Blue Channel Data 6
J3	E1_LVTX_CLKN	O	Negative output of LVDS TX E1 Clock Channel
			Odd Blue Channel Data 7
K3	E1_LVTX_CH2P	O	Positive output of LVDS TX E1 Channel 2
			Odd Green Channel Data 0
K4	E1_LVTX_CH2N	O	Negative output of LVDS TX E1 Channel 2
			Odd Green Channel Data 1
L2	E1_LVTX_CH1P	O	Positive output of LVDS TX E1 Channel 1
			Odd Green Channel Data 2
L3	E1_LVTX_CH1N	O	Negative output of LVDS TX E1 Channel 1
			Odd Green Channel Data 3

Table 5. Digital video outputs - LVDS &amp; TTL (suggested mapping)

Pin	Assignment	I/O	Description
M1	E1_LVTX_CH0P	O	Positive output of LVDS TX E1 Channel 0
			Odd Green Channel Data 4
M2	E1_LVTX_CH0N	O	Negative output of LVDS TX O1 Channel 3
			Odd Green Channel Data 5
L11	O0_LVTX_CH6P	O	Positive output of LVDS TX O0 Channel 6
			Data Enable Output. Default status HIGH.
M12	O0_LVTX_CH6N	O	Negative output of LVDS TX O0 Channel 6
			Data Clock Output. Default status HIGH.
M8	O0_LVTX_CH5P	O	Positive output of LVDS TX O0 Channel 5
			Even Blue Channel Data 8
L9	O0_LVTX_CH5N	O	Negative output of LVDS TX O0 Channel 5
			Even Blue Channel Data 9
P8	O0_LVTX_CH4P	O	Positive output of LVDS TX O0 Channel 4
			Even Blue Channel Data 2
N8	O0_LVTX_CH4N	O	Negative output of LVDS TX O0 Channel 4
			Even Blue Channel Data 3
N9	O0_LVTX_CH3P	O	Positive output of LVDS TX O0 Channel 3
			Even Green Channel Data 6
M9	O0_LVTX_CH3N	O	Negative output of LVDS TX O0 Channel 3
			Even Green Channel Data 7
M10	O0_LVTX_CLKP	O	Positive output of LVDS TX O0 Clock Channel
			Even Red Channel Data 0
L10	O0_LVTX_CLKN	O	Negative output of LVDS TX O0 Clock Channel
			Even Red Channel Data 1
N11	O0_LVTX_CH2P	O	Positive output of LVDS TX O0 Channel 2
			Even Red Channel Data 2
M11	O0_LVTX_CH2N	O	Negative output of LVDS TX O0 Channel 2
			Even Red Channel Data 3
P12	O0_LVTX_CH1P	O	Positive output of LVDS TX O0 Channel 1
			Even Red Channel Data 4
N12	O0_LVTX_CH1N	O	Negative output of LVDS TX O0 Channel 1
			Even Red Channel Data 5
P13	O0_LVTX_CH0P	O	Positive output of LVDS TX O0 Channel 0
			Even Red Channel Data 6

Table 5. Digital video outputs - LVDS &amp; TTL (suggested mapping)

Pin	Assignment	I/O	Description
N13	O0_LVTX_CH0N	O	Negative output of LVDS TX O0 Channel 0
			Even Red Channel Data 7
K10	O1_LVTX_CH6P	O	Positive output of LVDS TX O1 Channel 1
			Vertical Sync Output. Default status HIGH.
J11	O1_LVTX_CH6N	O	Negative output of LVDS TX O1 Channel 6
			Horizontal Sync Output. Default status HIGH.
J10	O1_LVTX_CH5P	O	Positive output of LVDS TX O1 Channel 5
			Odd Blue Channel Data 8
H11	O1_LVTX_CH5N	O	Negative output of LVDS TX O1 Channel 5
			Odd Blue Channel Data 9
M13	O1_LVTX_CH4P	O	Positive output of LVDS TX O1 Channel 4
			Odd Blue Channel Data 2
M14	O1_LVTX_CH4N	O	Negative output of LVDS TX O1 Channel 4
			Odd Blue Channel Data 3
L12	O1_LVTX_CH3P	O	Positive output of LVDS TX O1 Channel 3
			Odd Green Channel Data 6
L13	O1_LVTX_CH3N	O	Negative output of LVDS TX O1 Channel 3
			Odd Green Channel Data 7
K12	O1_LVTX_CLKP	O	Positive output of LVDS TX O1 Clock Channel
			Odd Red Channel Data 0
K11	O1_LVTX_CLKN	O	Negative output of LVDS TX O1 Clock Channel
			Odd Red Channel Data 1
J12	O1_LVTX_CH2P	O	Positive output of LVDS TX O1 Channel 2
			Odd Red Channel Data 2
J13	O1_LVTX_CH2N	O	Negative output of LVDS TX O1 Channel 2
			Odd Red Channel Data 3
H13	O1_LVTX_CH1P	O	Positive output of LVDS TX O1 Channel 1
			Odd Red Channel Data 4
H14	O1_LVTX_CH1N	O	Negative output of LVDS TX O1 Channel 1
			Odd Red Channel Data 5
G13	O1_LVTX_CH0P	O	Positive output of LVDS TX O1 Channel 0
			Odd Red Channel Data 6
G14	O1_LVTX_CH0N	O	Negative output of LVDS TX O1 Channel 0
			Odd Red Channel Data 7

**Table 6. Multi-function - digital audio output, general purpose input/output, bootstrap pins**

Pin	Assignment	I/O	Description
D2	I2S_MCLK/GPIO_4	I/O	I <sup>2</sup> S Audio Master Clock
			General Purpose Schmitt Trigger Input / Tri-state Output 4 [5V Tolerant]
D3	I2S_WCLK/BOOT[0]/GPIO_6	I/O	I <sup>2</sup> S Audio Word Select
			Bootstrap 0. Please refer to Bootstrap Configuration Table for description.
			General Purpose Schmitt Trigger Input / Tri-state Output 6 [5V Tolerant]
C2	I2S_BCLK/BOOT[1]/GPIO_7	I/O	I <sup>2</sup> S Audio Bit Clock
			Bootstrap 1. Please refer to Bootstrap Configuration Table for description.
			General Purpose Schmitt Trigger Input / Tri-state Output 7 [5V Tolerant]
B1	I2S_0/BOOT[2]/GPIO_8	I/O	I <sup>2</sup> S Audio Data 0 / SPDIF output
			Bootstrap 2. Please refer to Bootstrap Configuration Table for description.
			General Purpose Schmitt Trigger Input / Tri-state Output 8 [5V Tolerant]
G5	I2S_1/BOOT[3]/GPIO_9	I/O	I <sup>2</sup> S Audio Data 1 / SPDIF output
			Bootstrap 3. Please refer to Bootstrap Configuration Table for description.
			General Purpose Schmitt Trigger Input / Tri-state Output 9 [5V Tolerant]
F4	I2S_2/BOOT[4]/GPIO_10	I/O	I <sup>2</sup> S Audio Data 2 / SPDIF output
			Bootstrap 4. Please refer to Bootstrap Configuration Table for description.
			General Purpose Schmitt Trigger Input / Tri-state Output 10 [5V Tolerant]
E3	I2S_3/BOOT[5]/GPIO_11	I/O	I <sup>2</sup> S Audio Data 3 / SPDIF output
			Bootstrap 5. Please refer to Bootstrap Configuration Table for description.
			General Purpose Schmitt Trigger Input / Tri-state Output 11 [5V Tolerant]

**Table 7. Multi-function and system interface connections**

Pin	Assignment	I/O	Description
E5	RESET <sub>n</sub>	I/O	Reset (active low) signal. Connect to digital 3.3 V with a 2.7 K ohm pull-up resistor.
F3	TESTMODE0	I	Reserve for testing. Must be connected to system ground (GND)
G3	TESTMODE1	I	

**Table 7. Multi-function and system interface connections**

Pin	Assignment	I/O	Description
D13	SPI_DI/GPIO_19	I/O	SPI ROM Data Input.
			General Purpose Schmitt Trigger Input / Tri-state Output 19 [5V Tolerant]
E11	SPI_DO/GPIO_20	I/O	SPI ROM Data Output.
			General Purpose Schmitt Trigger Input / Tri-state Output 20 [5V Tolerant]
E12	SPI_CLK/GPIO_18	I/O	SPI ROM Clock
			General Purpose Schmitt Trigger Input / Tri-state Output 18 [5V Tolerant]
F12	SPI_CS <sub>n</sub> /GPIO_17	I/O	SPI ROM Chip Select.
			General Purpose Schmitt Trigger Input / Tri-state Output 17 [5V Tolerant]
E6	GPIO_0	I/O	General Purpose Schmitt Trigger Input / Tri-state Output 0 [5V Tolerant]
C3	GPIO_1	I/O	General Purpose Schmitt Trigger Input / Tri-state Output 1 [5V Tolerant]
G10	I2C_MST_SCL/GPIO_2	I/O	Master I <sup>2</sup> C Serial Clock (for accessing external I <sup>2</sup> C devices). Pull up with 4.7K ohm resistor.
			General Purpose Schmitt Trigger Input / Tri-state Output 2 [5V Tolerant]
F11	I2C_MST_SDA/GPIO_3	I/O	Master I <sup>2</sup> C Serial Data (for accessing external I <sup>2</sup> C devices). Pull up with 4.7K ohm resistor.
			General Purpose Schmitt Trigger Input / Tri-state Output 3 [5V Tolerant]
C1	CLK_OUT/GPIO_5	I/O	Clock Output
			General Purpose Schmitt Trigger Input / Tri-state Output 5 [5V Tolerant]
G4	IR_IN/GPIO_12	I/O	Infra-red Receiver Data Input
			General Purpose Schmitt Trigger Input / Tri-state Output 12 [5V Tolerant]
A1	UART_TX/BOOT[6]/GPIO_13	I/O	UART Transmit Data Output.
			Bootstrap 6. Please refer to Bootstrap Configuration Table for description.
			General Purpose Schmitt Trigger Input / Tri-state Output 13 [5V Tolerant]
E4	UART_RX/GPIO_14	I/O	UART Receive Data Input. Pull up with 4.7K ohm resistor.
			General Purpose Schmitt Trigger Input / Tri-state Output 14 [5V Tolerant]



**Table 7. Multi-function and system interface connections**

Pin	Assignment	I/O	Description
C13	AUX_I2C_SCL/GPIO_15	I/O	I <sup>2</sup> C Serial Clock for DP AUX channel. This pin, along with AUX_I2C_SDA, creates external serial interface for DP AUX channel. Connect to digital 3.3V with 4.7K ohm resistor.
			General Purpose Schmitt Trigger Input / Tri-state Output 15 [5V Tolerant]
B14	AUX_I2C_SDA/GPIO_16	I/O	I <sup>2</sup> C Data Clock for DP AUX channel. This pin, along with AUX_I2C_SCL, creates external serial interface for DP AUX channel. Connect to digital 3.3V with 4.7K ohm resistor.
			General Purpose Schmitt Trigger Input / Tri-state Output 16 [5V Tolerant]
B13	I2C_SCL/GPIO_21	I/O	I <sup>2</sup> C_SCL. Pull up to 3.3V with 4.7K ohm resistor.
			General Purpose Schmitt Trigger Input / Tri-state Output 21 [5V Tolerant]
D11	I2C_SDA/GPIO_22	I/O	I <sup>2</sup> C_SDA. Pull up to 3.3V with 4.7K ohm resistor.
			General Purpose Schmitt Trigger Input / Tri-state Output 22 [5V Tolerant]
B12	AUX_UART_TX/BOOT[7]/GPIO_23	I/O	UART Transmit Data Output for DP AUX channel.
			Bootstrap 7. Please refer to Bootstrap Configuration Table for description.
			General Purpose Schmitt Trigger Input / Tri-state Output 23 [5V Tolerant]
A12	AUX_UART_RX/GPIO_24	I/O	UART Receive Data Input for DP AUX channel. Pull up with 4.7K ohm resistor.
			General Purpose Schmitt Trigger Input / Tri-state Output 24 [5V Tolerant]
D12	IRQ/GPIO_25	I/O	IRQ. Interrupt Output.
			General Purpose Schmitt Trigger Input / Tri-state Output 25 [5V Tolerant]

**Table 8. No connects**

Pin	Assignment	I/O	Description
G11	NC1	-	No connection.
G12	NC2	-	
C11	NC3	-	
A13	NC4	-	
B4	NC5	-	

Table 9. System power and ground

Pin	Assignment	I/O	Description
C12, E7, E8, K6, K9	PVDD1	P	Digital 1.2V VDD. Connect to digital 1.2V with 0.1 $\mu$ F bypass capacitor.
F10	PVDD21	P	Digital 3.3V VDD. Connect to digital 3.3V with 0.1 $\mu$ F bypass capacitor. Must be connected at same voltage level.
F5	PVDD22		
A14, C4, C14, F6, F7, F8, F9, G6, G7, G8, G9, H6, H7, H8, H9, J6, J7, J8, J9	PVSS3	G	Digital Ground. Each pin must be connected directly to digital ground plane.
B11, C7, C8, D9	DPRX_VDDA_1V2	P	DisplayPort Receiver Analog 1.2V Power Supply. Must be bypassed with a 0.1 $\mu$ F capacitor to analog ground plane on board.
D7, D8, E9, E10	DPRX_VSSA	G	DisplayPort Receiver VSS. Must be directly connected to analog ground plane on board.
B2	VSS_RPLL	G	Analog Ground for the DDS Reference PLL and Digital Core. Must be directly connected to analog ground plane on board.
B3	VDD_RPLL	P	Analog 1.2V Power Supply for RCLK PLL and Digital Core. Must be bypassed with a 0.1 $\mu$ F capacitor to analog ground plane on board.
D6	VDDA_3V3	P	Analog 3.3V VDD. Connect to analog 3.3V with 0.1 $\mu$ F bypass capacitor to analog ground plane on board.
H3, H12, L8, N1, N14	AVDD_OUT_LVTX_33	P	Analog 3.3V VDD. Connect to analog 3.3V with 0.1 $\mu$ F bypass capacitor to analog ground plane on board.
L7	AVDD_LVTX_33	P	Analog 3.3V VDD. Connect to analog 3.3V with 0.1 $\mu$ F bypass capacitor to analog ground plane on board.
F2, F13, H5, H10, K8, P1, P14	AVSS_OUT_LVTX	G	Analog ground. Must connect directly to analog ground plane on board.
K7	AVSS_LVTX	G	Analog ground. Must connect directly to analog ground plane on board.

## 5.2 Bootstrap configuration

During hardware reset, on the rising edge of RESETn, logic high or low configuration on bootstrap pins are latched and stored. 4.7K pull-up or pull-down resistors must be installed to indicate logic '1' or '0'