



Chipsmall Limited consists of a professional team with an average of over 10 year of expertise in the distribution of electronic components. Based in Hongkong, we have already established firm and mutual-benefit business relationships with customers from,Europe,America and south Asia,supplying obsolete and hard-to-find components to meet their specific needs.

With the principle of “Quality Parts,Customers Priority,Honest Operation,and Considerate Service”,our business mainly focus on the distribution of electronic components. Line cards we deal with include Microchip,ALPS,ROHM,Xilinx,Pulse,ON,Everlight and Freescale. Main products comprise IC,Modules,Potentiometer,IC Socket,Relay,Connector.Our parts cover such applications as commercial,industrial, and automotives areas.

We are looking forward to setting up business relationship with you and hope to provide you with the best service and solution. Let us make a better world for our industry!



Contact us

Tel: +86-755-8981 8866 Fax: +86-755-8427 6832

Email & Skype: info@chipsmall.com Web: www.chipsmall.com

Address: A1208, Overseas Decoration Building, #122 Zhenhua RD., Futian, Shenzhen, China





STEVAL-CCA021V1

USB audio demonstration board based on the STM32F103RE and TS4657

Data brief

Features

- STM32F103RE performance line microcontroller
- 16 MHz crystal unit
- USB connector and ESD protection
- Two LEDs driven by the microcontroller
- Push button to control the firmware mode
- TS4657 - single supply stereo digital audio line driver with 2.2 V_{RMS} capless outputs:
 - 16- to 24-bit audio data format stereo DAC, 32 to 48 kHz sample rate
 - I²S, right or left-justified compatible digital audio interface
- TS2012 - filter-free stereo 2x2.8 W class D audio power amplifier
- TS4962 - 2.8 W filter-free mono class D audio power amplifier
 - Output available either through mono jack connector or to on-board speaker
- TS472 - very low noise microphone preamplifier with 2.0 V bias output and active low standby mode
 - Single-ended output available for connection to ADC of a microcontroller
- On-board microphone and small speaker
- RoHS compliant



Description

The STEVAL-CCA021V1 demonstration board implements a USB audio card based on the STM32F103RE microcontroller and the TS4657 audio digital-to-analog converter (decoder). The complete system consists of a controller board driven by the STM32F103RE microcontroller, and a TS4657-based audio board.

Mono audio output is available either through the TS4962-driven on-board speaker or via the mono jack connector, and stereo output is possible through the TS2012 stereo audio amplifier which can drive external speakers. Both audio amplifiers are class D.

For audio input, an on-board microphone is connected through the TS472 microphone pre-amplifier to the ADC input of the microcontroller. It is possible to disconnect the controller section from the audio section to use the boards individually for other applications.

1 Schematic diagrams

Figure 1. Schematic diagram of the STM32F103RE-based controller board

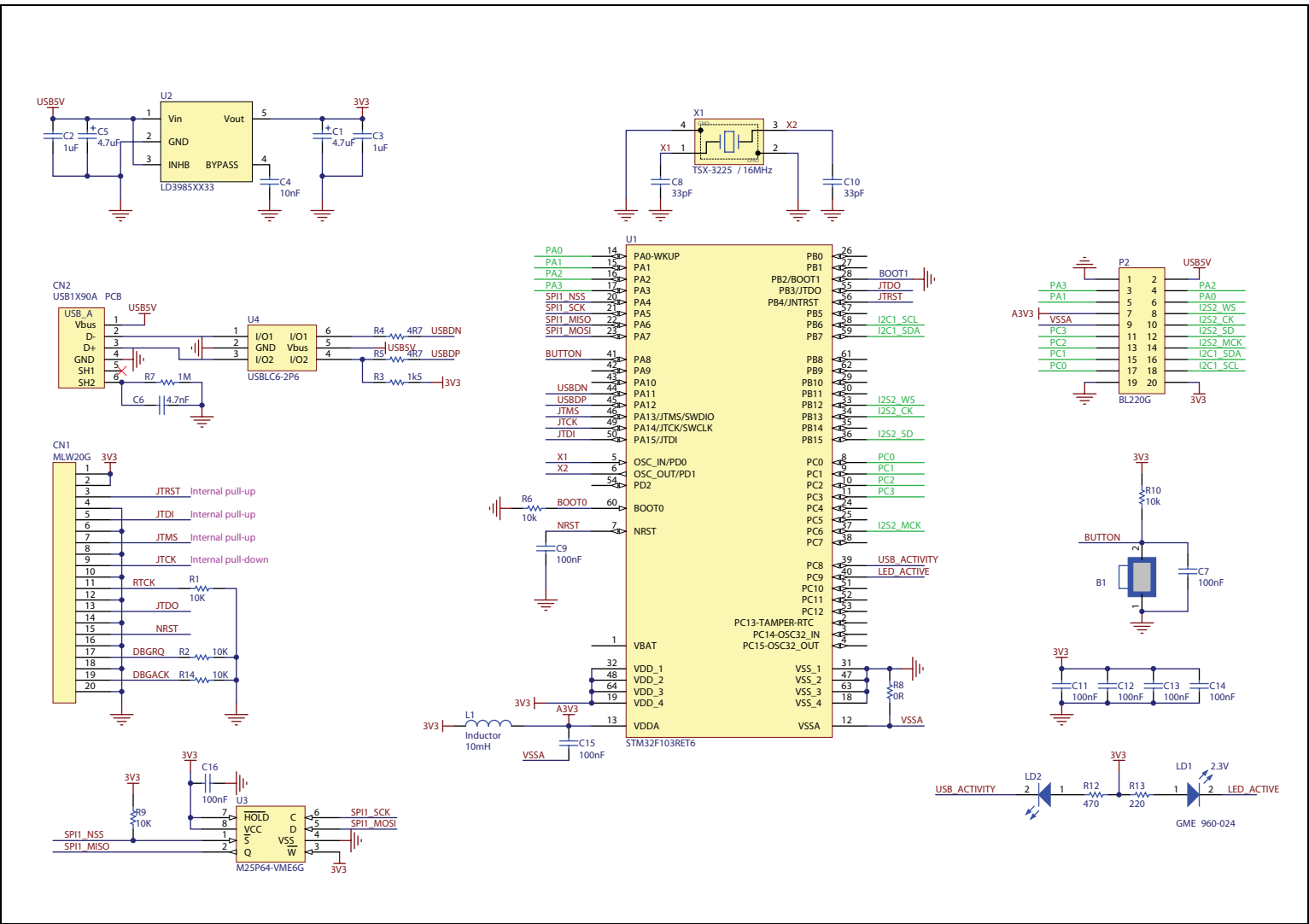

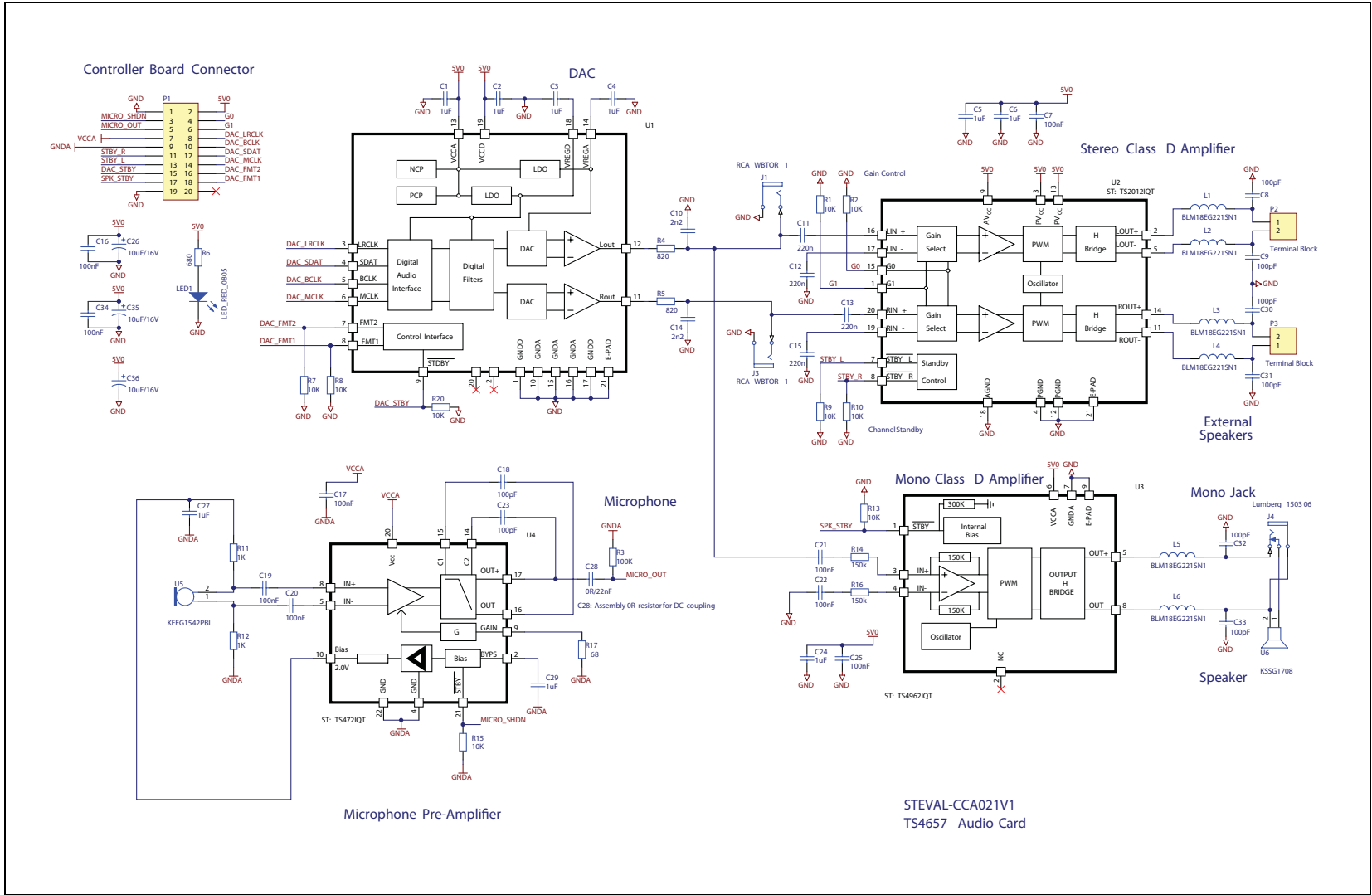

Figure 2. Schematic circuit of the TS4657-based audio board

2 Revision history

Table 1. Document revision history

Date	Revision	Changes
29-Sep-2009	1	Initial release.

Please Read Carefully:

Information in this document is provided solely in connection with ST products. STMicroelectronics NV and its subsidiaries ("ST") reserve the right to make changes, corrections, modifications or improvements, to this document, and the products and services described herein at any time, without notice.

All ST products are sold pursuant to ST's terms and conditions of sale.

Purchasers are solely responsible for the choice, selection and use of the ST products and services described herein, and ST assumes no liability whatsoever relating to the choice, selection or use of the ST products and services described herein.

No license, express or implied, by estoppel or otherwise, to any intellectual property rights is granted under this document. If any part of this document refers to any third party products or services it shall not be deemed a license grant by ST for the use of such third party products or services, or any intellectual property contained therein or considered as a warranty covering the use in any manner whatsoever of such third party products or services or any intellectual property contained therein.

UNLESS OTHERWISE SET FORTH IN ST'S TERMS AND CONDITIONS OF SALE ST DISCLAIMS ANY EXPRESS OR IMPLIED WARRANTY WITH RESPECT TO THE USE AND/OR SALE OF ST PRODUCTS INCLUDING WITHOUT LIMITATION IMPLIED WARRANTIES OF MERCHANTABILITY, FITNESS FOR A PARTICULAR PURPOSE (AND THEIR EQUIVALENTS UNDER THE LAWS OF ANY JURISDICTION), OR INFRINGEMENT OF ANY PATENT, COPYRIGHT OR OTHER INTELLECTUAL PROPERTY RIGHT.

UNLESS EXPRESSLY APPROVED IN WRITING BY AN AUTHORIZED ST REPRESENTATIVE, ST PRODUCTS ARE NOT RECOMMENDED, AUTHORIZED OR WARRANTED FOR USE IN MILITARY, AIR CRAFT, SPACE, LIFE SAVING, OR LIFE SUSTAINING APPLICATIONS, NOR IN PRODUCTS OR SYSTEMS WHERE FAILURE OR MALFUNCTION MAY RESULT IN PERSONAL INJURY, DEATH, OR SEVERE PROPERTY OR ENVIRONMENTAL DAMAGE. ST PRODUCTS WHICH ARE NOT SPECIFIED AS "AUTOMOTIVE GRADE" MAY ONLY BE USED IN AUTOMOTIVE APPLICATIONS AT USER'S OWN RISK.

Resale of ST products with provisions different from the statements and/or technical features set forth in this document shall immediately void any warranty granted by ST for the ST product or service described herein and shall not create or extend in any manner whatsoever, any liability of ST.

ST and the ST logo are trademarks or registered trademarks of ST in various countries.

Information in this document supersedes and replaces all information previously supplied.

The ST logo is a registered trademark of STMicroelectronics. All other names are the property of their respective owners.

© 2009 STMicroelectronics - All rights reserved

STMicroelectronics group of companies

Australia - Belgium - Brazil - Canada - China - Czech Republic - Finland - France - Germany - Hong Kong - India - Israel - Italy - Japan - Malaysia - Malta - Morocco - Philippines - Singapore - Spain - Sweden - Switzerland - United Kingdom - United States of America

www.st.com