



Chipsmall Limited consists of a professional team with an average of over 10 year of expertise in the distribution of electronic components. Based in Hongkong, we have already established firm and mutual-benefit business relationships with customers from,Europe,America and south Asia,supplying obsolete and hard-to-find components to meet their specific needs.

With the principle of “Quality Parts,Customers Priority,Honest Operation,and Considerate Service”,our business mainly focus on the distribution of electronic components. Line cards we deal with include Microchip,ALPS,ROHM,Xilinx,Pulse,ON,Everlight and Freescale. Main products comprise IC,Modules,Potentiometer,IC Socket,Relay,Connector.Our parts cover such applications as commercial,industrial, and automotives areas.

We are looking forward to setting up business relationship with you and hope to provide you with the best service and solution. Let us make a better world for our industry!



## Contact us

Tel: +86-755-8981 8866 Fax: +86-755-8427 6832

Email & Skype: info@chipsmall.com Web: www.chipsmall.com

Address: A1208, Overseas Decoration Building, #122 Zhenhua RD., Futian, Shenzhen, China



### 4 x 10 W class-AB amplifier demonstration board based on the STA540SAN

#### Introduction

This application note describes the STEVAL-CCA040V1 demonstration board designed for the evaluation of the STA540SAN which contains four single-ended class-AB amplifiers assembled in the Clipwatt15 package. The device is able to deliver 4 x 10 W in single-ended (SE) configuration with  $V_{CC}$  at 17 V and a 4  $\Omega$  load or 2 x 26 W in bridge-tied load (BTL) configuration with  $V_{CC}$  at 14.4 V and a 4  $\Omega$  load.

This application note provides details on the demonstration board connections, performance (operating characteristics), and suggestions for layout design in order to avoid critical issues. The board schematics are also included in this document.

**Figure 1. STEVAL-CCA040V1**



# Contents

- 1        Reference documents and terminology ..... 3**
  
- 2        Test conditions, connections and electrical characteristics of the  
         demonstration board ..... 4**
  - 2.1    Power supply and interface connections ..... 4
  - 2.2    Output configuration ..... 4
  - 2.3    Equipment requirement and connections ..... 4
  - 2.4    Output configuration settings ..... 5
  - 2.5    Electrical characteristics ..... 7
  
- 3        Board schematics and PCB layout ..... 8**
  - 3.1    Board schematic ..... 8
  - 3.2    PCB layout ..... 9
  - 3.3    Design guidelines for schematic and PCB layout ..... 10
    - 3.3.1    Schematic ..... 10
    - 3.3.2    Layout ..... 10
  
- 4        Operating characteristics ..... 12**
  - 4.1    Single-ended output configuration ..... 12
  - 4.2    BTL output configuration ..... 16
  
- 5        Thermal information ..... 20**
  - 5.1    Calculating power dissipation ..... 20
  - 5.2    Selecting the heatsink ..... 20
  
- 6        Revision history ..... 21**



# 1 Reference documents and terminology

Reference documents for operation of the demonstration board include:

- STA540SAN datasheet
- Schematic diagram
- PCB layout
- Operating characteristics

The terminology and acronyms used in this document are defined as follows:

- **THD+N vs. Pout:** Total Harmonic Distortion (THD) plus noise versus output power
- **THD+N vs. Freq:** Total Harmonic Distortion plus noise versus frequency
- **S/N ratio:** Signal-to-Noise ratio
- **FFT:** Fast Fourier Transform algorithm (method)
- **Xtalk:** Channel separation OUT1 to OUT2 or OUT2 to OUT1 and OUT3 to Out4 or OUT4 to OUT3 channel crosstalk

## 2 Test conditions, connections and electrical characteristics of the demonstration board

### 2.1 Power supply and interface connections

Connect the power supply to the VCC connector (CN7), supply voltage ranging from 8 V to 22 V.

Connect the analog input cable to the RCA connectors (CN1) on the demonstration board. The other side must be connected to a signal source such as Audio Precision analog outputs or a DVD player.

### 2.2 Output configuration

The STEVAL-CCA040V1 demonstration board can be configured to have a 4-channel single-ended output, a 2-channel BTL output or a 2-channel single-ended output plus 1-channel BTL output.

### 2.3 Equipment requirement and connections

The equipment needed to operate the board includes:

- Audio generator and analyzer Audio Precision AP 2722
- Oscilloscope Tektronix 3034B
- DC power supply
- Dummy load

Figure 2. Test wiring diagram

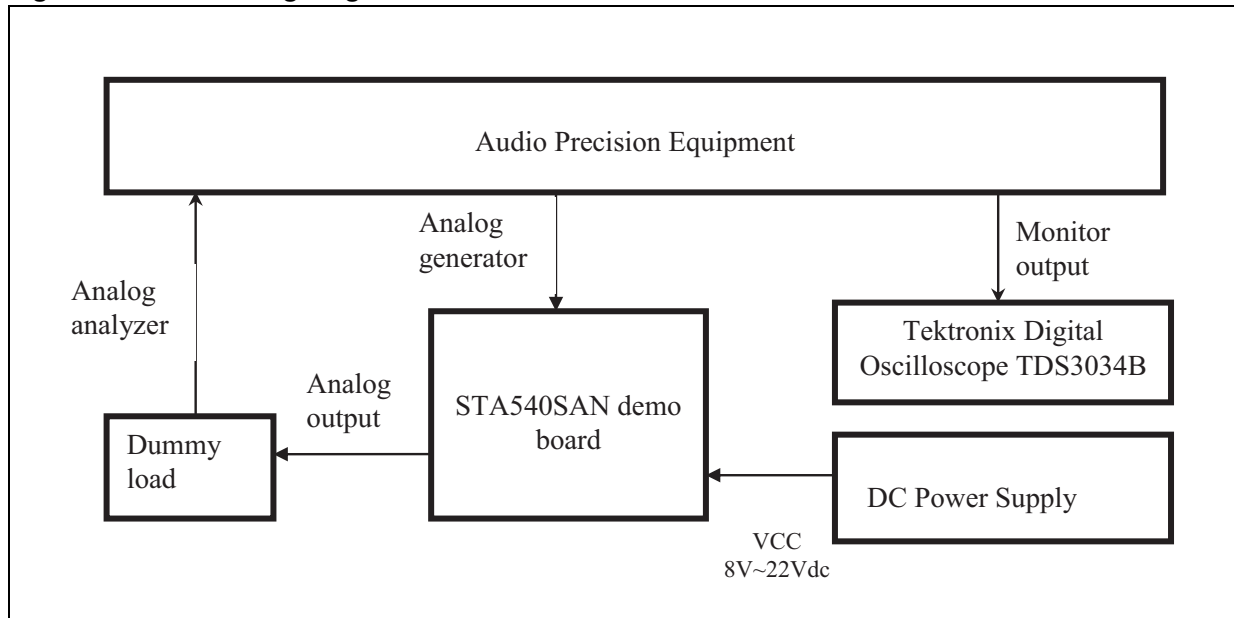

Figure 3. STEVAL-CCA040V1 overview

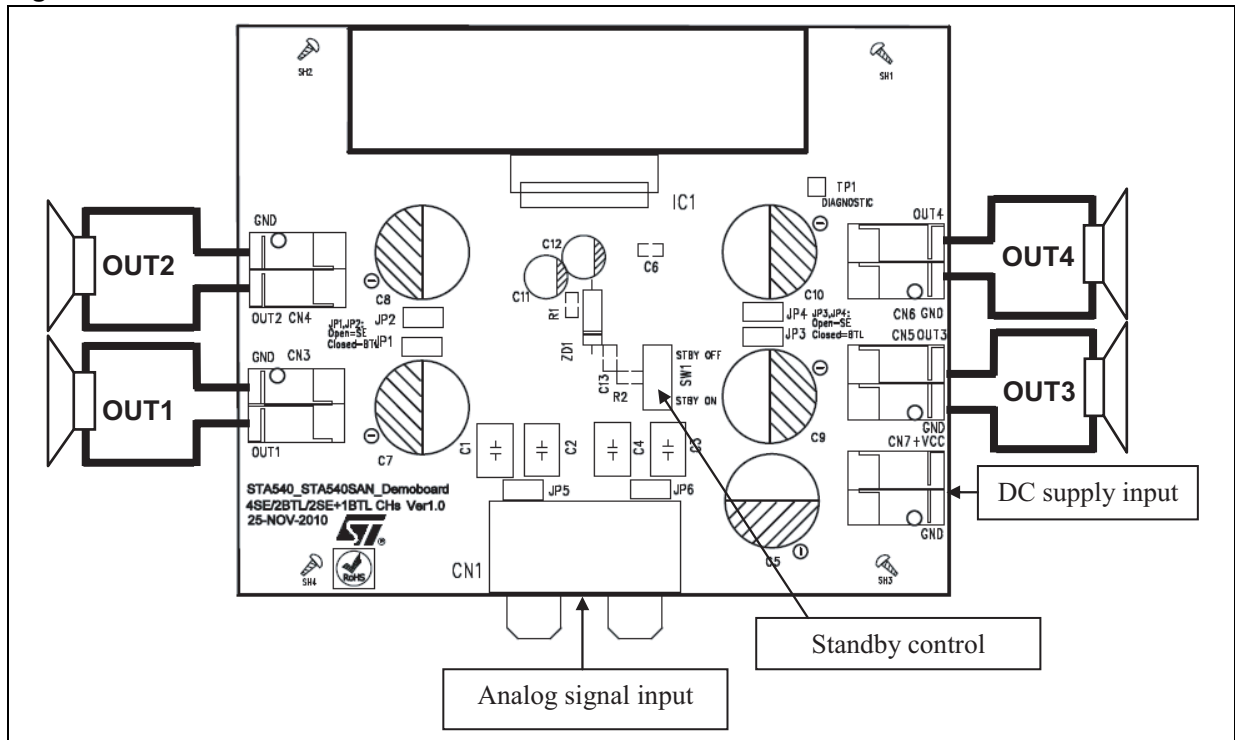

Figure 4. 4-channel single-ended configuration

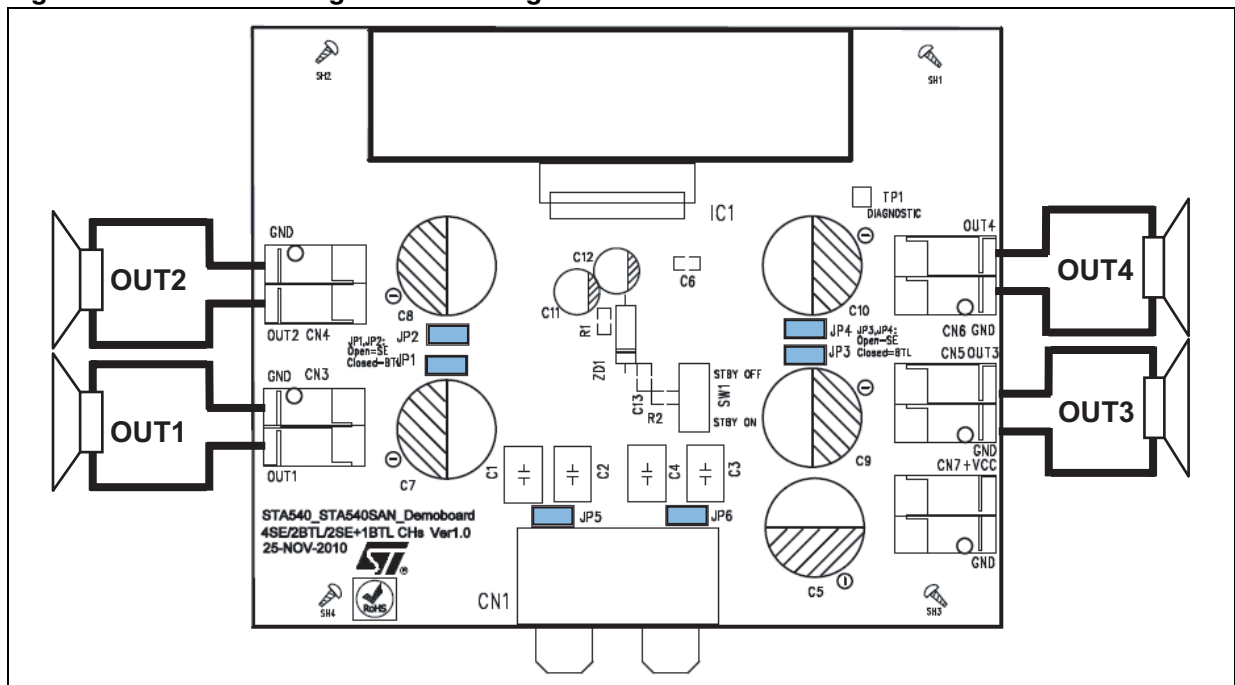
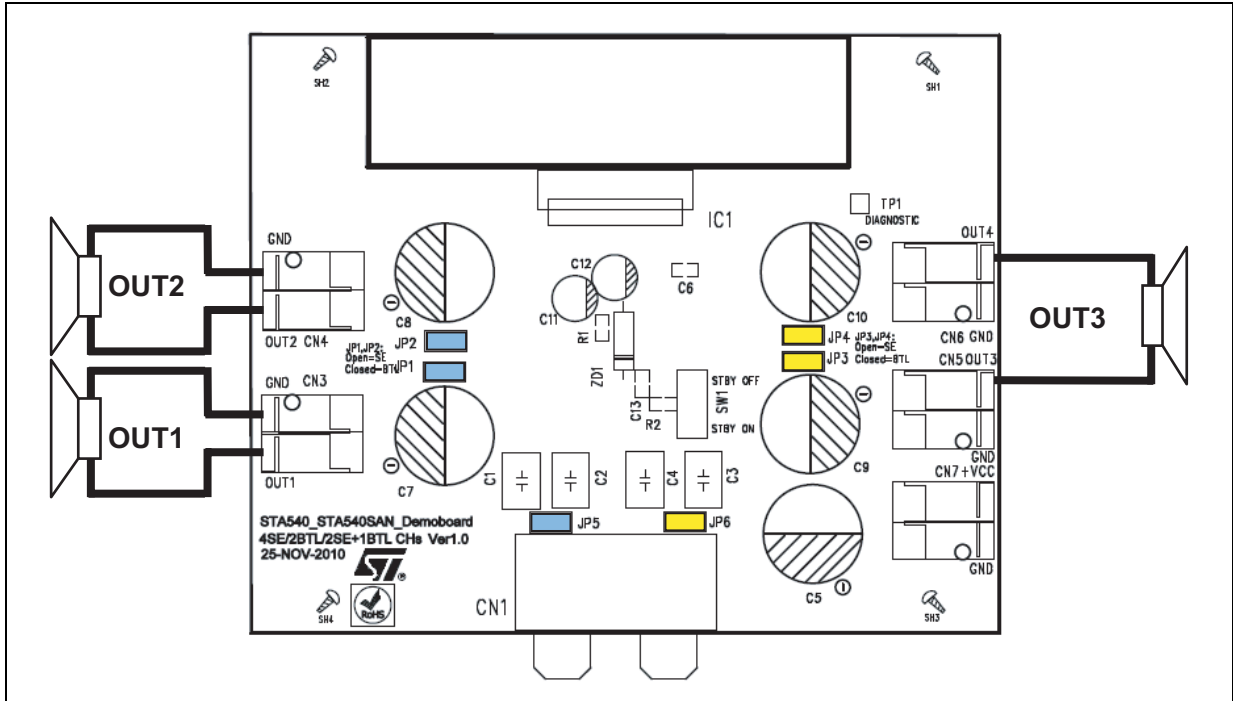
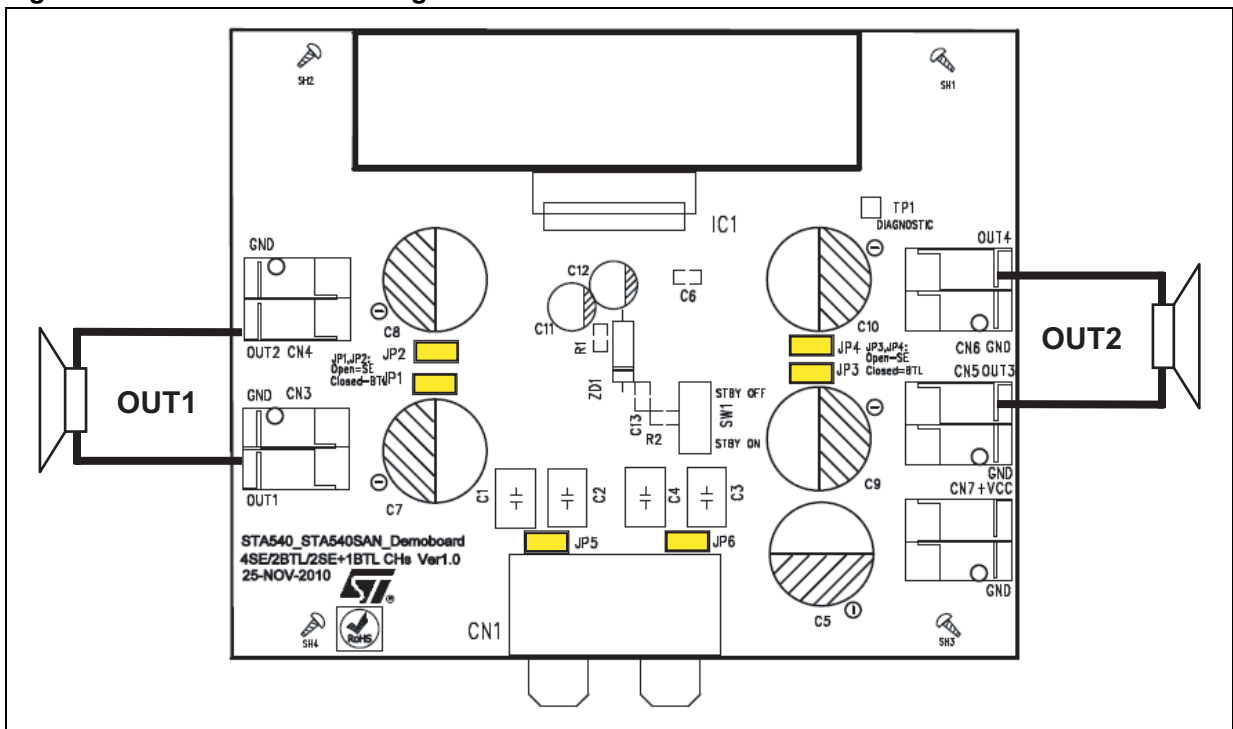

Figure 5. 2-channel single-ended and 1-channel BTL configuration



Note: Jumpers in blue are open, jumpers in yellow are closed.

Figure 6. 2-channel BTL configuration



Note: Jumpers in yellow are closed.

## 2.5 Electrical characteristics

The following table shows the output for the 4 single-ended and BTL configurations given the following conditions:

Vcc = +17 V, Gain 20 dB; Tamb=25.5 °C; Input Freq = 1 kHz; Ref Level=1 W (0 dBr), Load = 4 Ω (resistive dummy load).

**Table 1. Electrical characteristics**

Parameter	Condition	Result
THD+N vs. power	Pout = 1 W	0.0555%
Output power 10% THD	Single-ended	10 W
	BTL (Vcc at 14.4 V)	26 W
Iocp		3.5 A
SNR	No filter	-70.5 dB
	AW - filter	-92.3 dB
Xtalk	1kHz	-65.8 dB





### 3 Board schematics and PCB layout

#### 3.1 Board schematic

Figure 7. STEVAL-CCA040V1 schematic

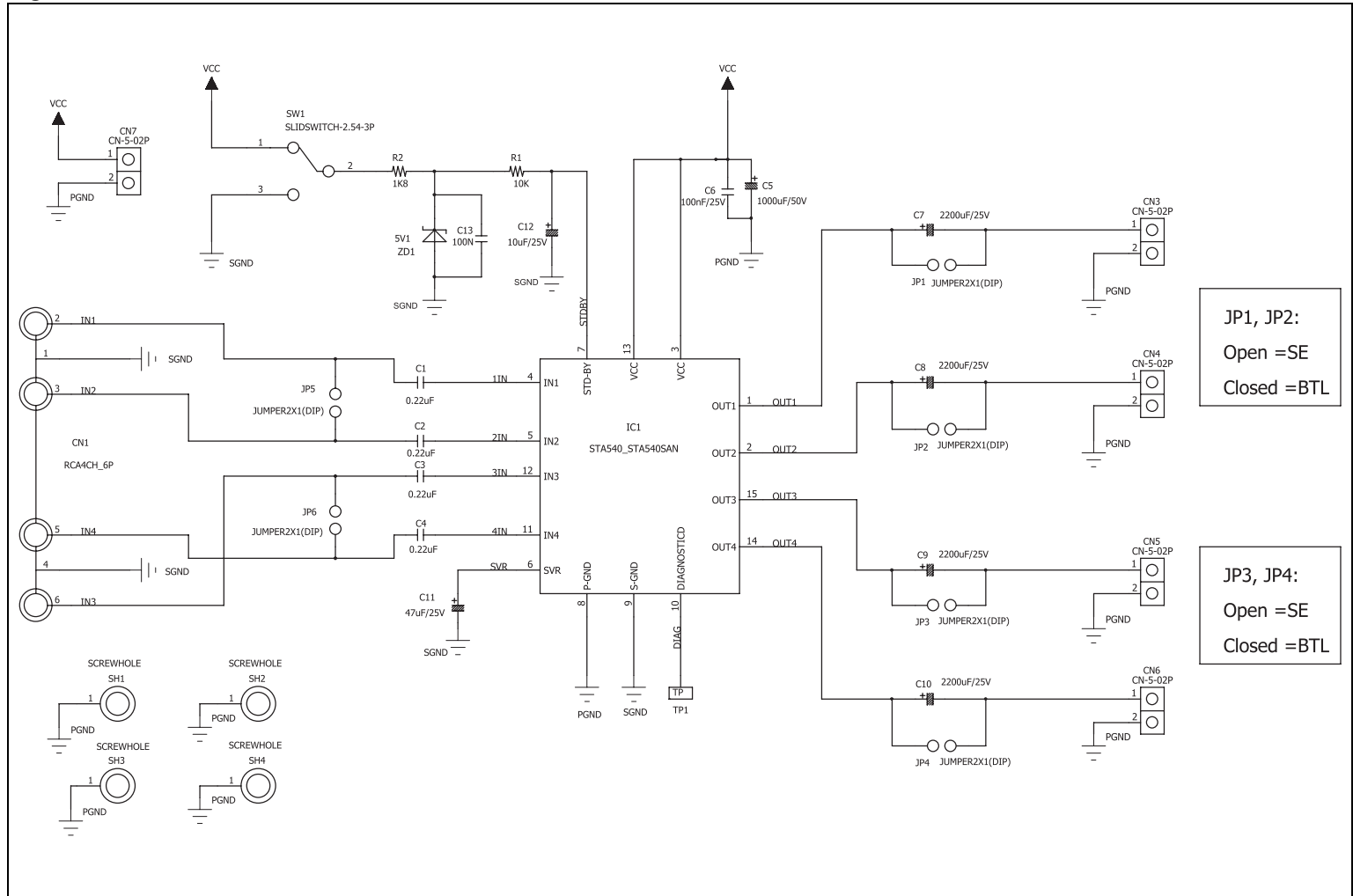

### 3.2 PCB layout

Figure 8. PCB layout - top view

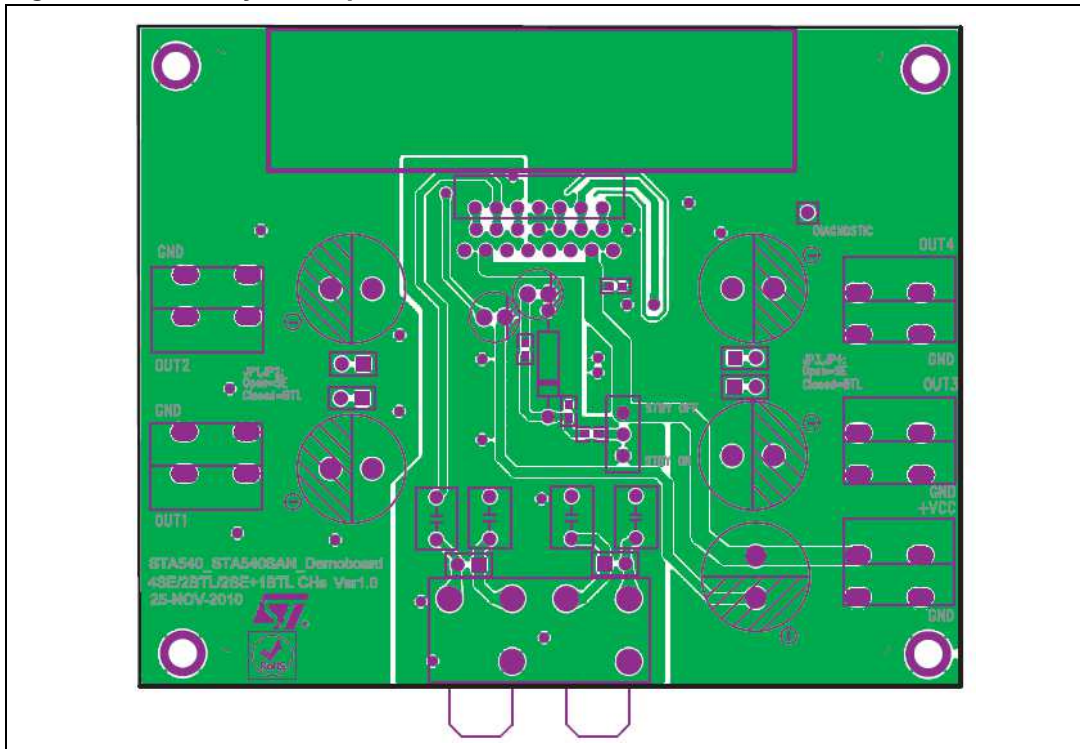
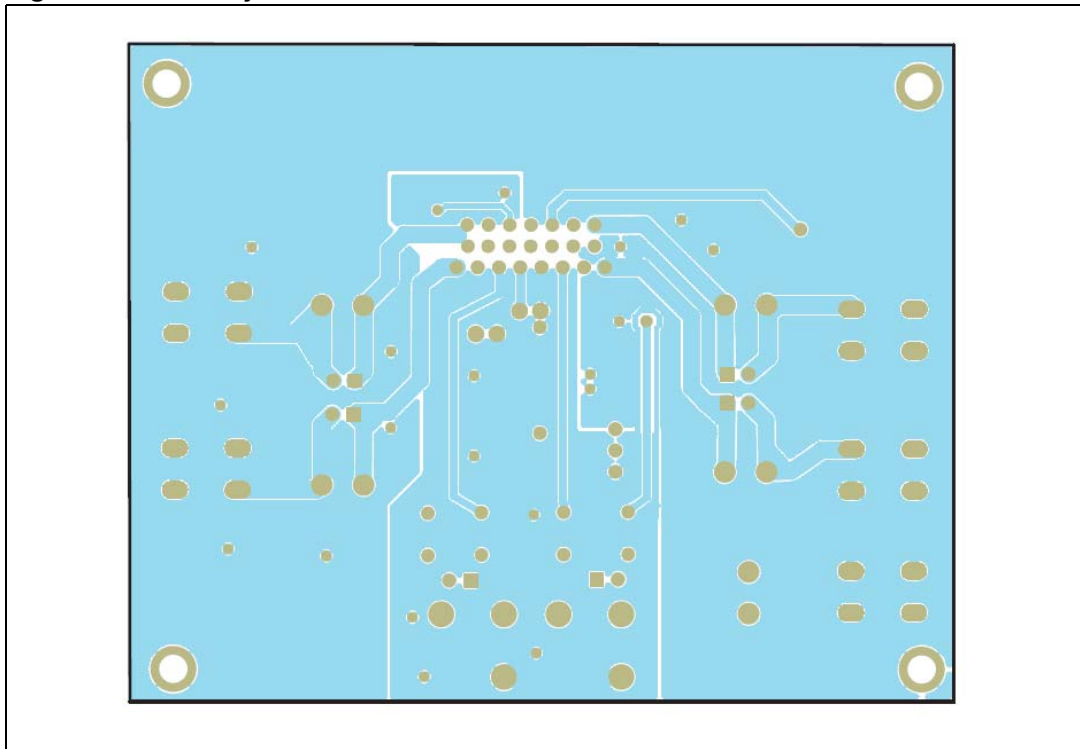

Figure 9. PCB layout - bottom view



### 3.3 Design guidelines for schematic and PCB layout

#### 3.3.1 Schematic

##### Criteria for selection of components

- Absolute maximum rate (input  $V_{CC}$  supply voltage ): 24 V
- Output DC-decoupling capacitor 2200  $\mu\text{F}$  for each single-ended power output is recommended

##### Decoupling capacitors

There are two different ways to utilize these capacitors:

- The decoupling capacitor(s) can be shared among channels; the layout must be designed to implement a "star route" for the  $V_{CC}$  paths.
- One decoupling capacitor can be used for each channel. A 100 nF decoupling capacitor (mandatory) must be placed as close as possible to the IC pins. This solution is implemented in the STA540SAN demonstration board.

##### Driving the standby pin

The STA540SAN standby pin cannot be directly driven by a voltage source having current capability higher than 5 mA, so a 10k ohm plus 10  $\mu\text{F}$  RC network has been inserted between the external control signal and standby pin of the STA540SAN.

#### 3.3.2 Layout

The following layout recommendations should be implemented:

- To avoid the effect due to the parasitic inductive coil generated by the copper wires, an SMD type ceramic capacitor (100 nF) is recommended in order to balance the reactance. The ceramic capacitor (mandatory) must be placed as close as possible to the related pins.

Figure 10. Decoupling capacitors

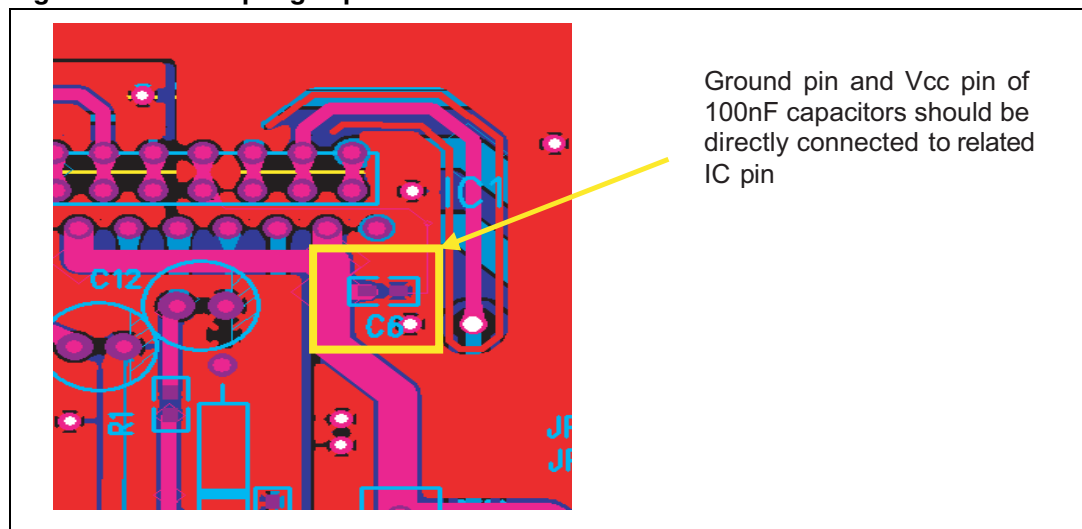

- Signal ground and power ground routing should be connected to the bulk capacitor negative terminal. The signal ground is separated from the power ground routing.
- Standby capacitor ground, SVR capacitor ground and input signal ground should be connected to S\_GND.
- SVR capacitor should be placed as close as possible to the STA540SAN

Figure 11. Signal ground and power ground routing (top)

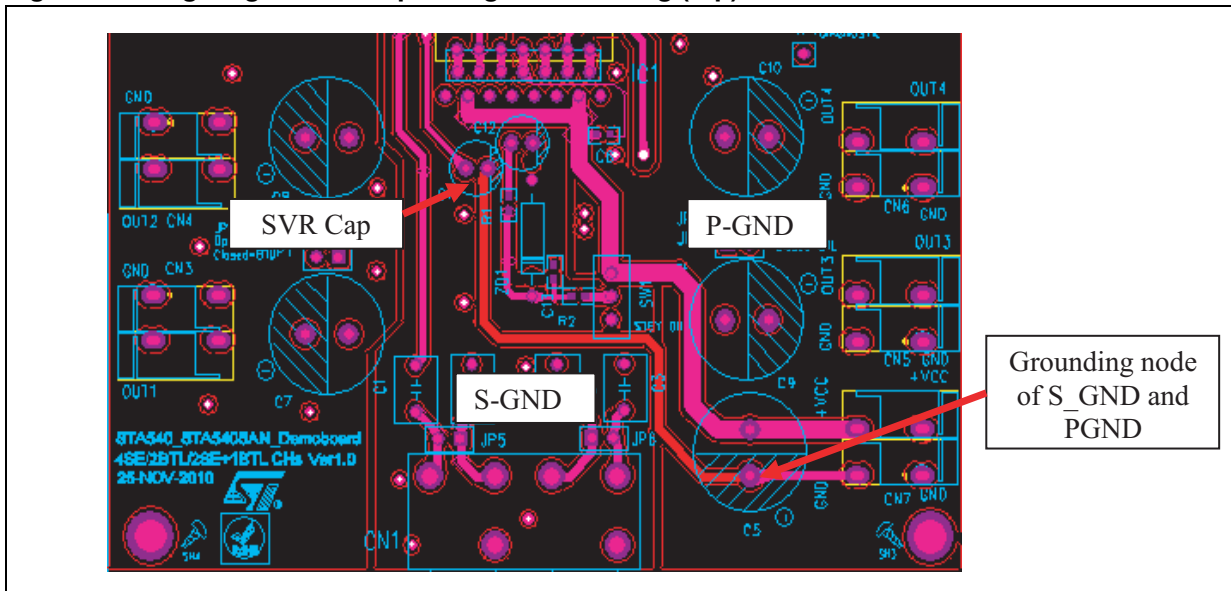
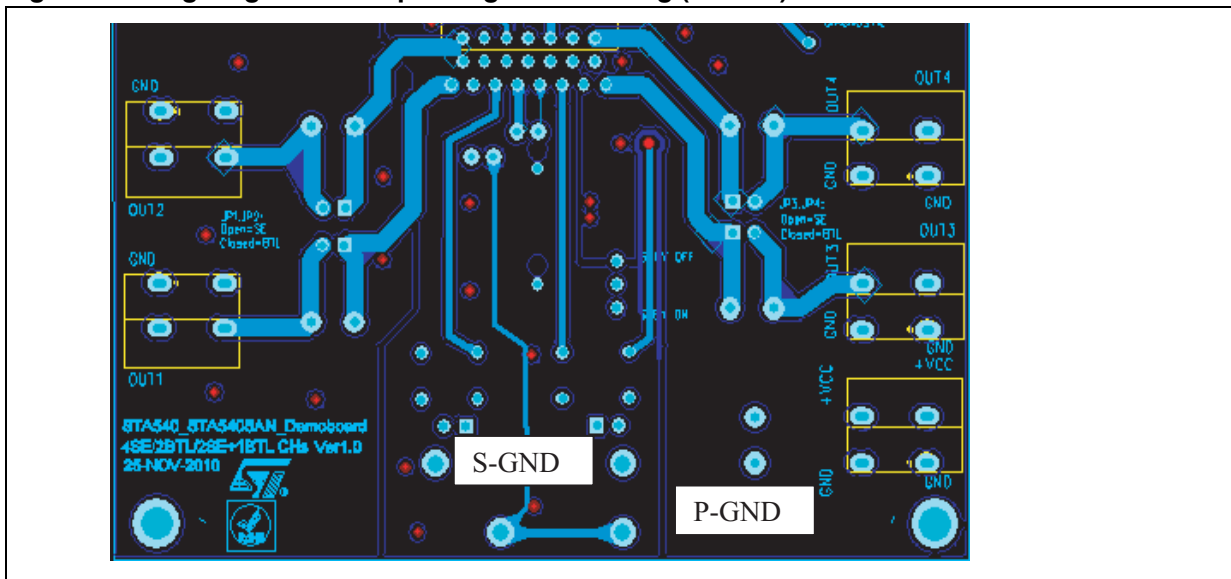

Figure 12. Signal ground and power ground routing (bottom)



## 4 Operating characteristics

### 4.1 Single-ended output configuration

Figure 13. SE output power vs. supply voltage

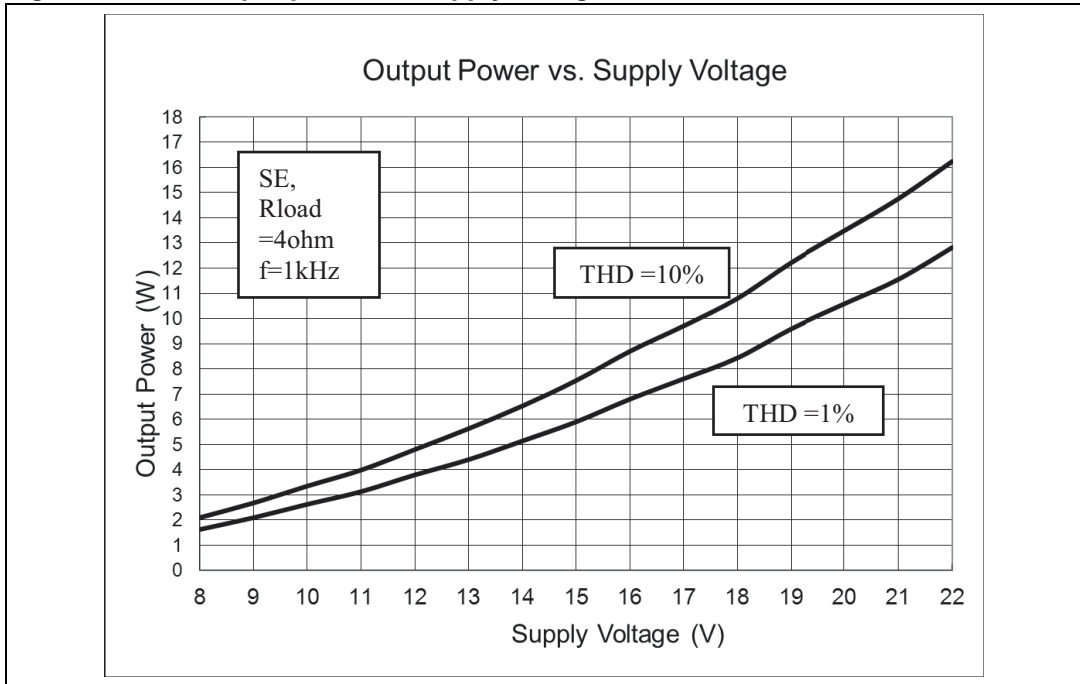

Figure 14. SE THD vs. output power,  $V_{CC} = 17 V$

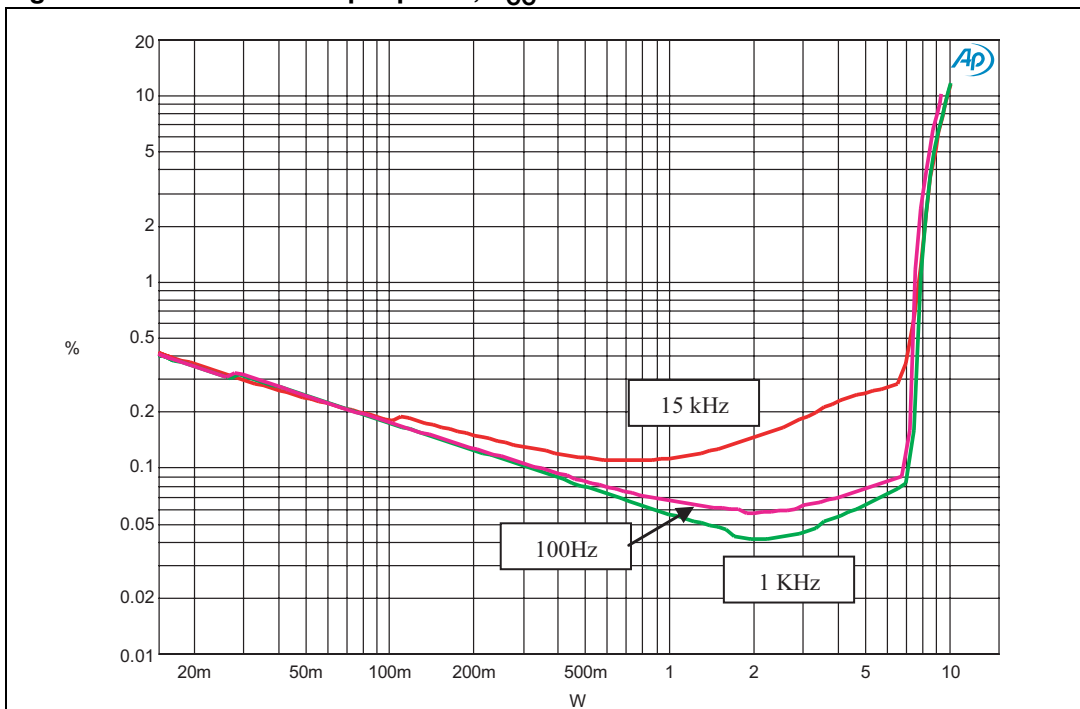



Figure 15. SE THD vs. frequency

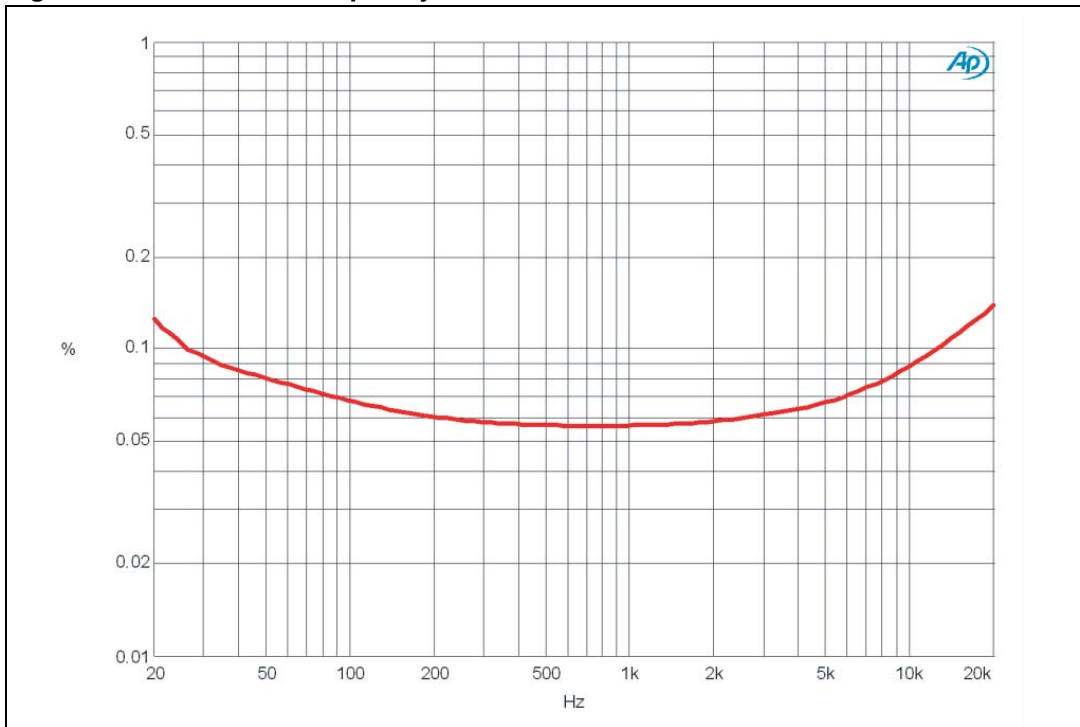

Figure 16. SE frequency response at 1 W output

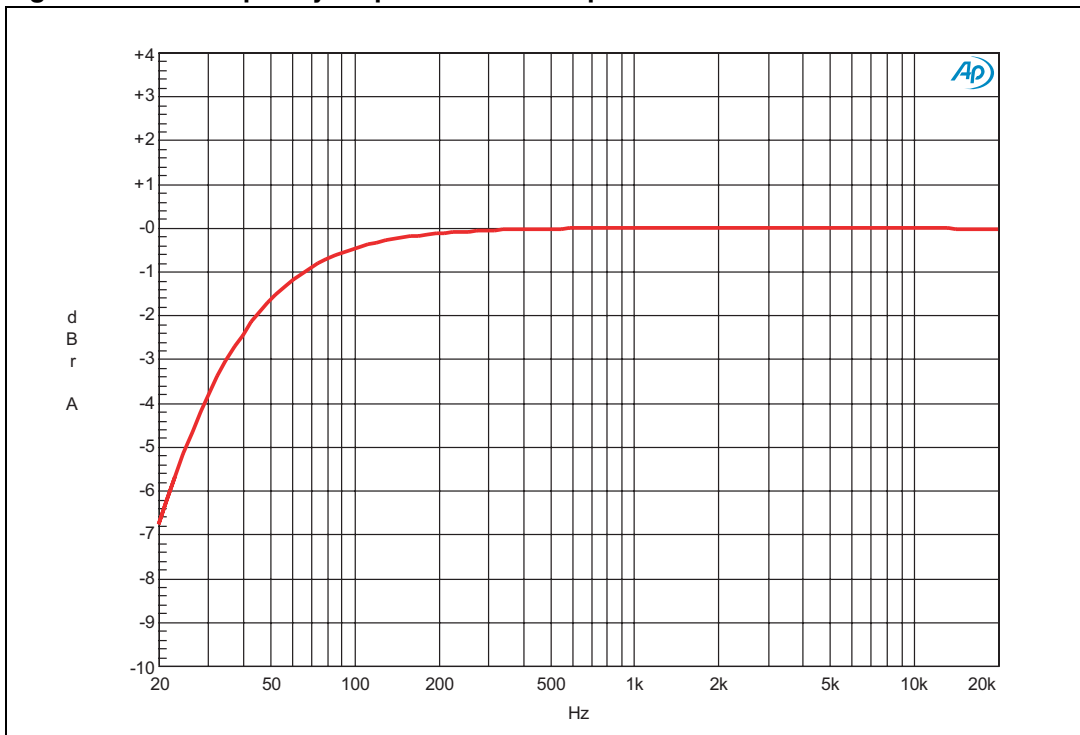

Figure 17. SE signal-to-noise ratio at 1 W output

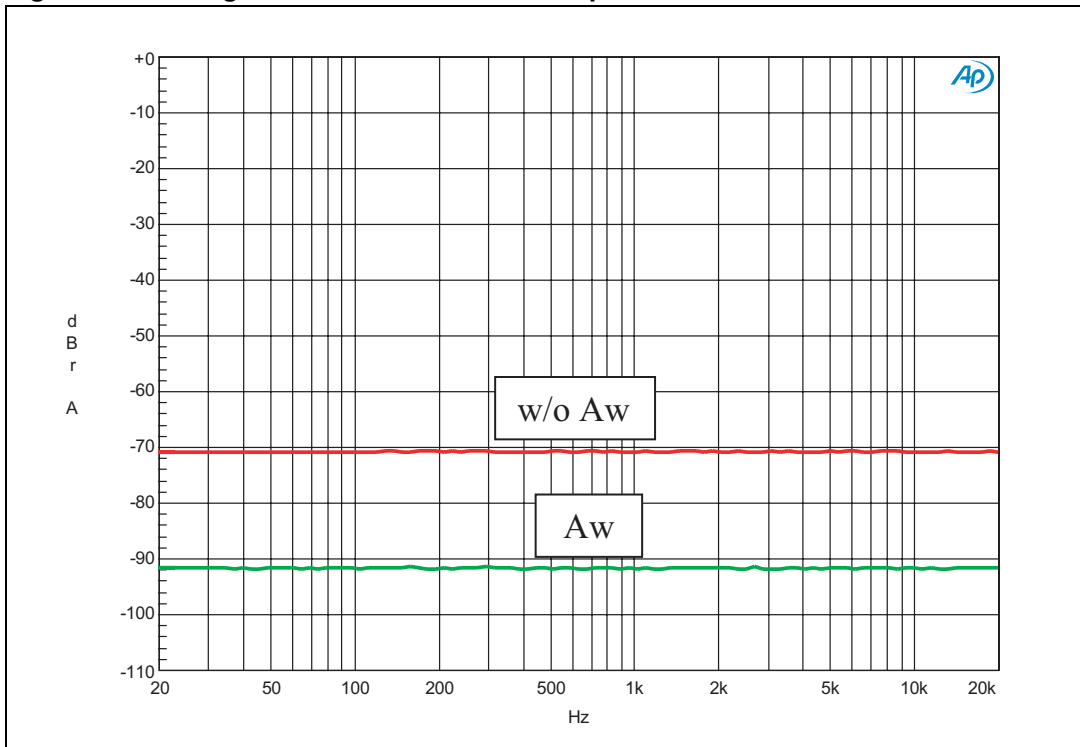

Figure 18. SE FFT 1 kHz, 0 dB at 1 W output

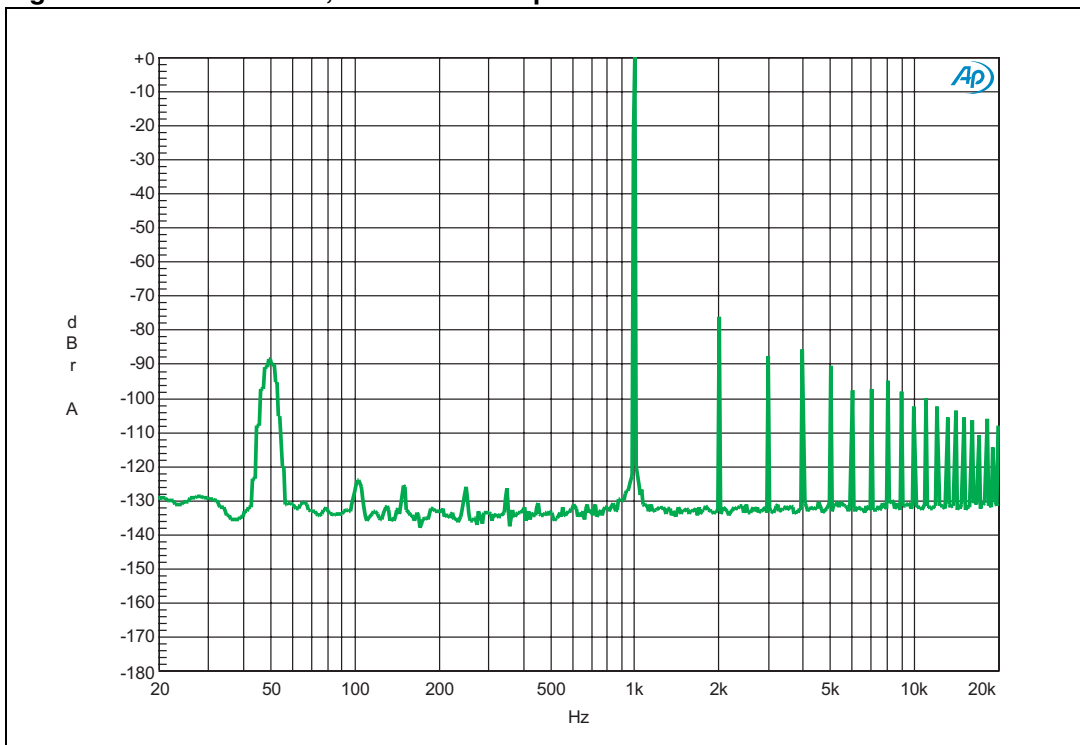

Figure 19. SE FFT 1 kHz, -60 dB at 1 W output

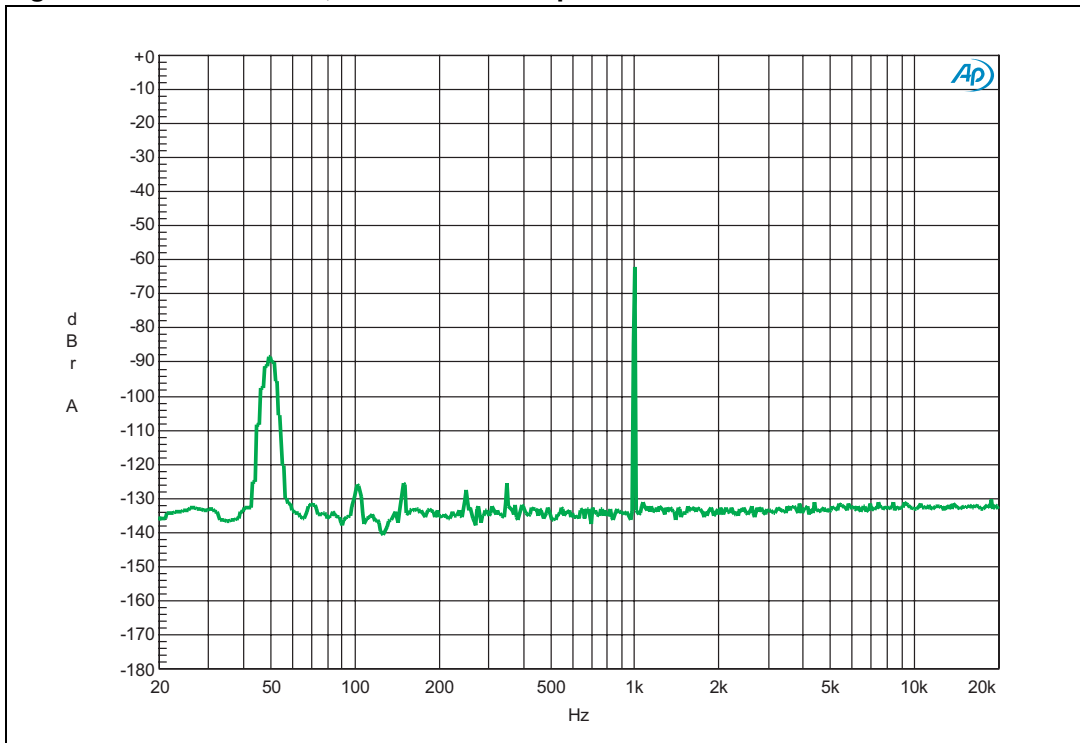
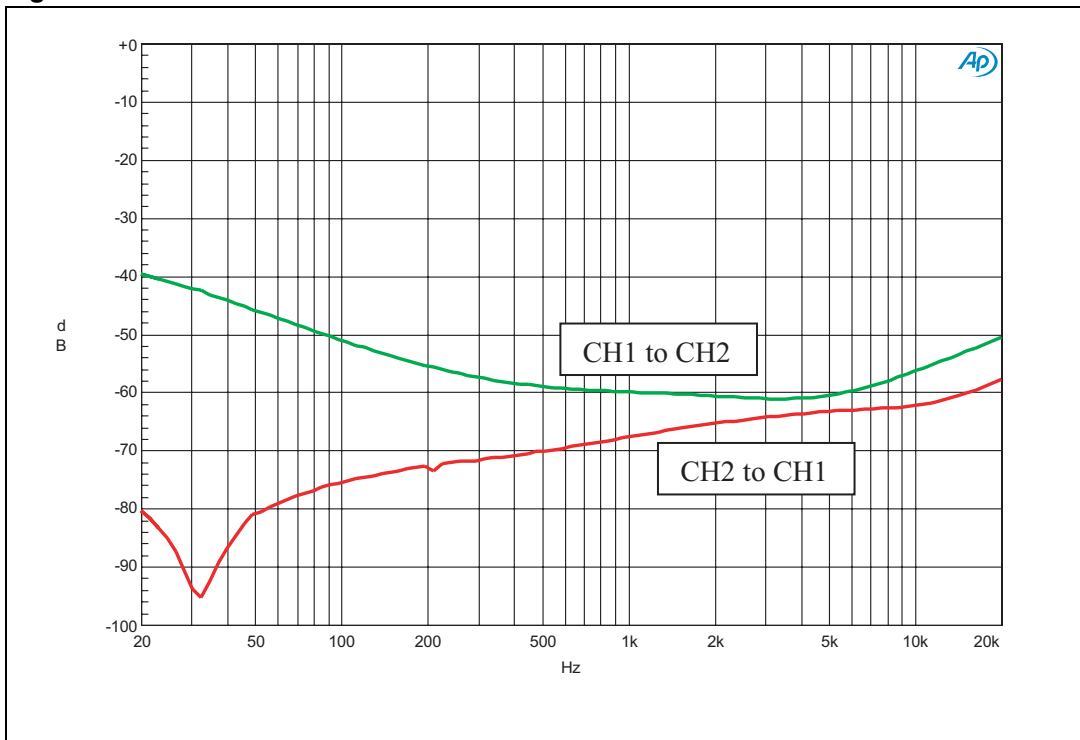

Figure 20. SE Xtalk CH1 vs. CH2



## 4.2 BTL output configuration

Figure 21. BTL output power vs. supply voltage

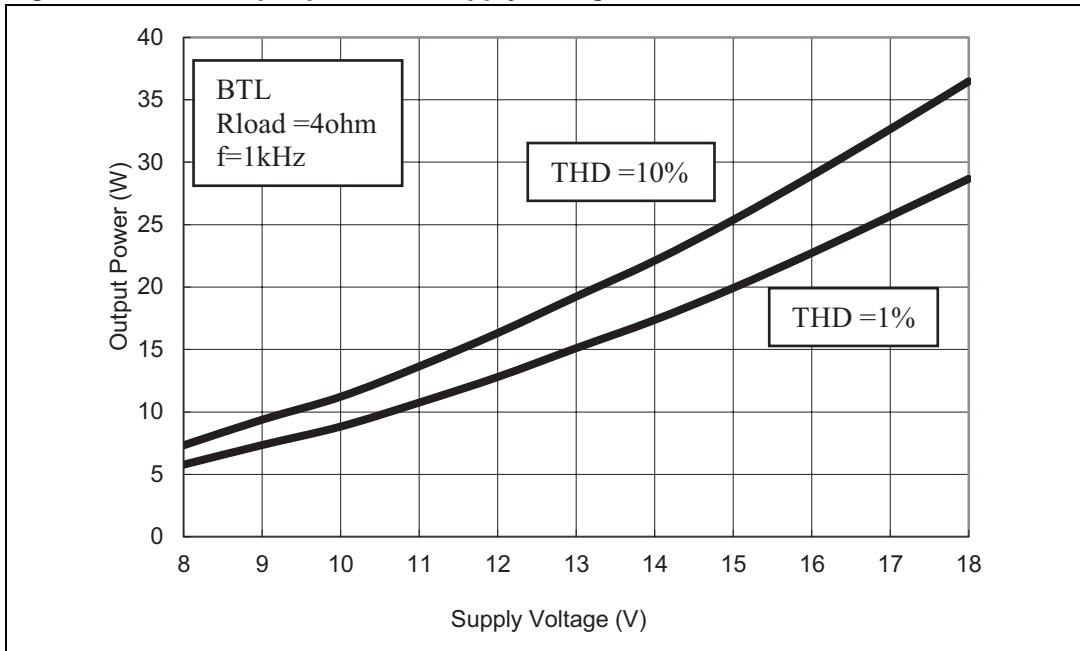

Figure 22. BTL THD vs. output power

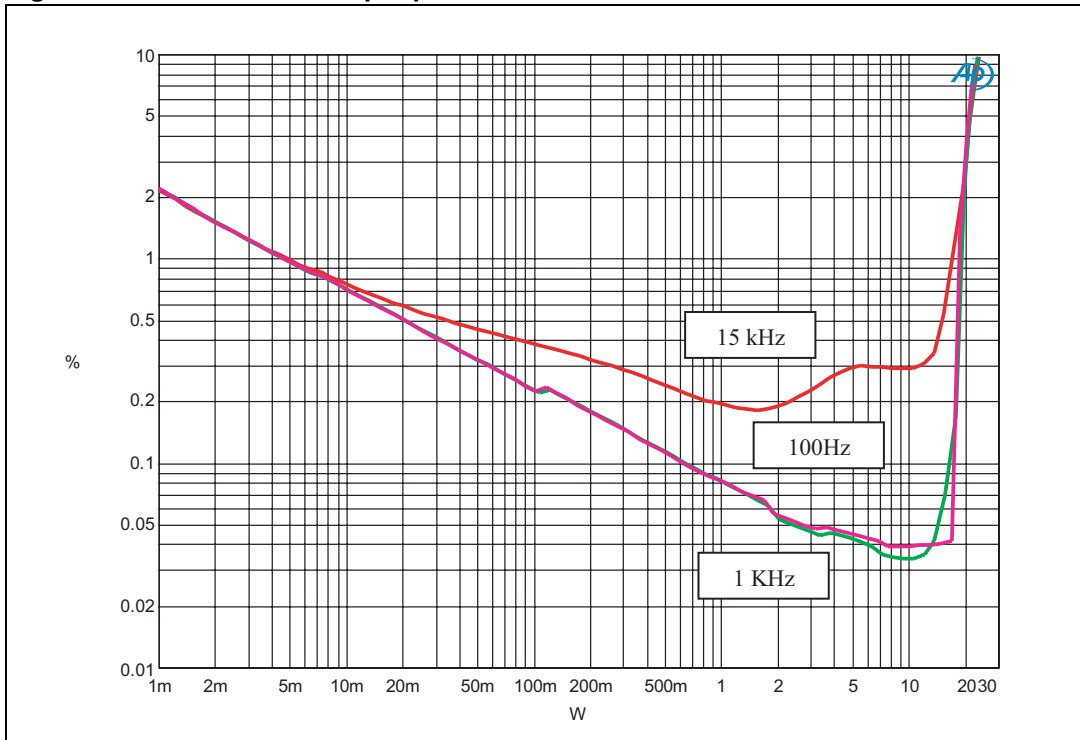

Figure 23. BTL THD vs. frequency

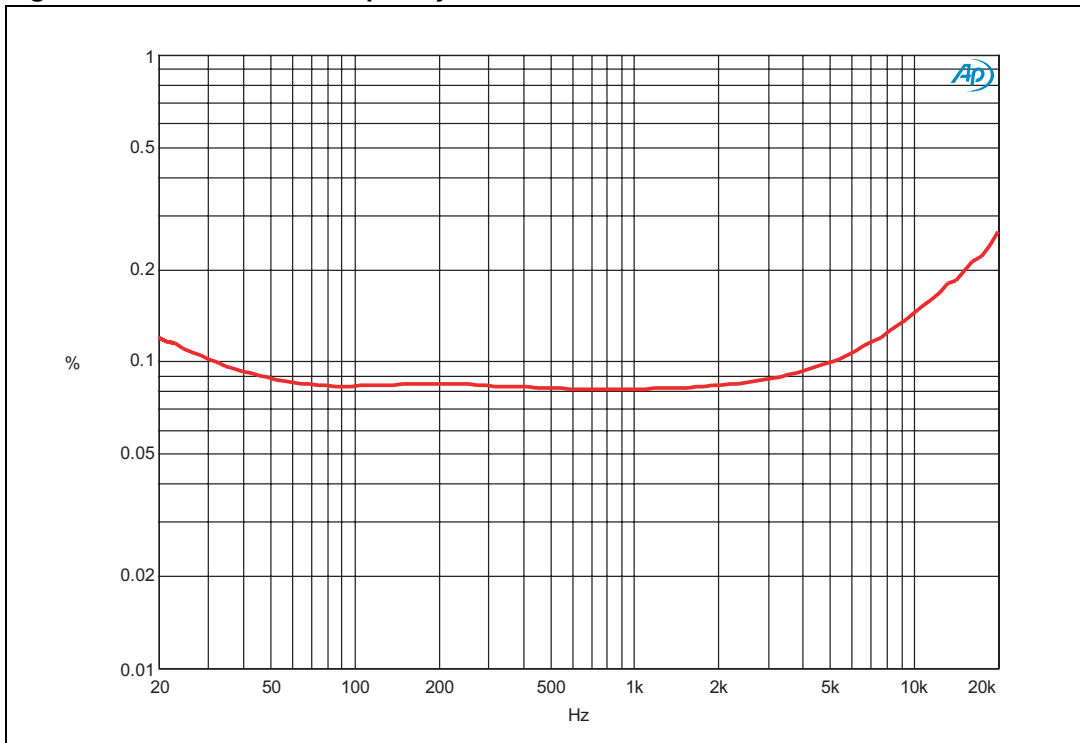

Figure 24. BTL frequency response at 1 W output

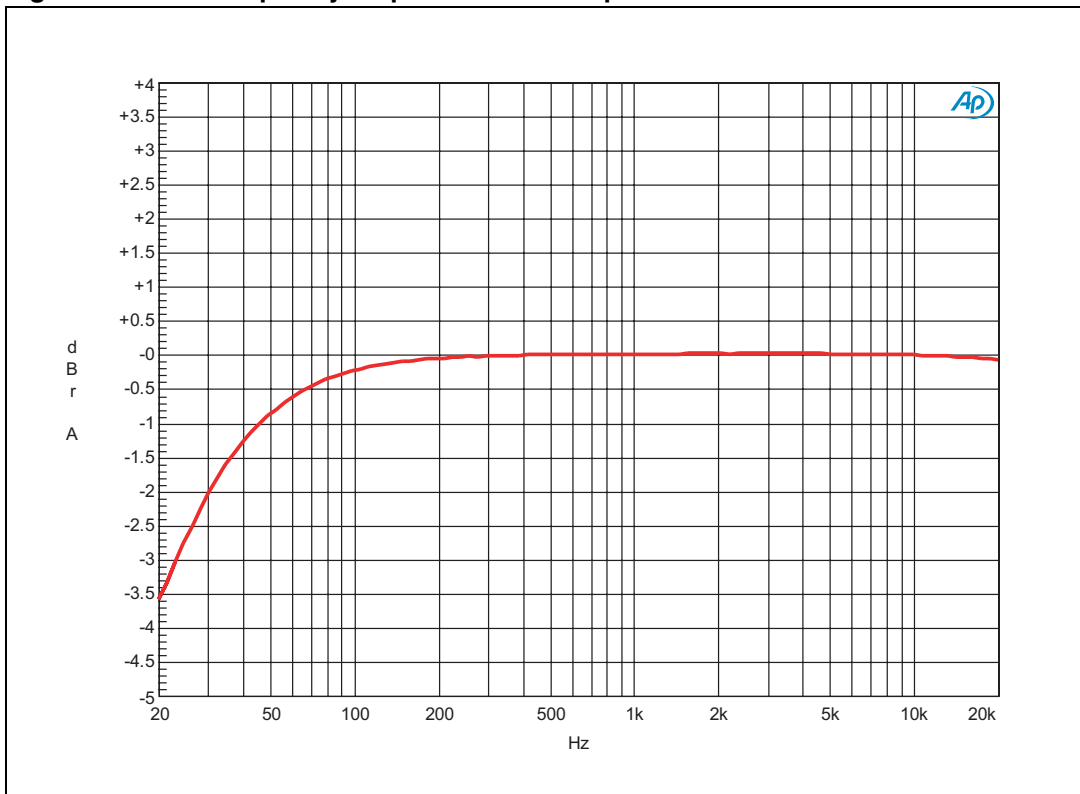



Figure 25. BTL signal-to-noise ratio at 1 W output

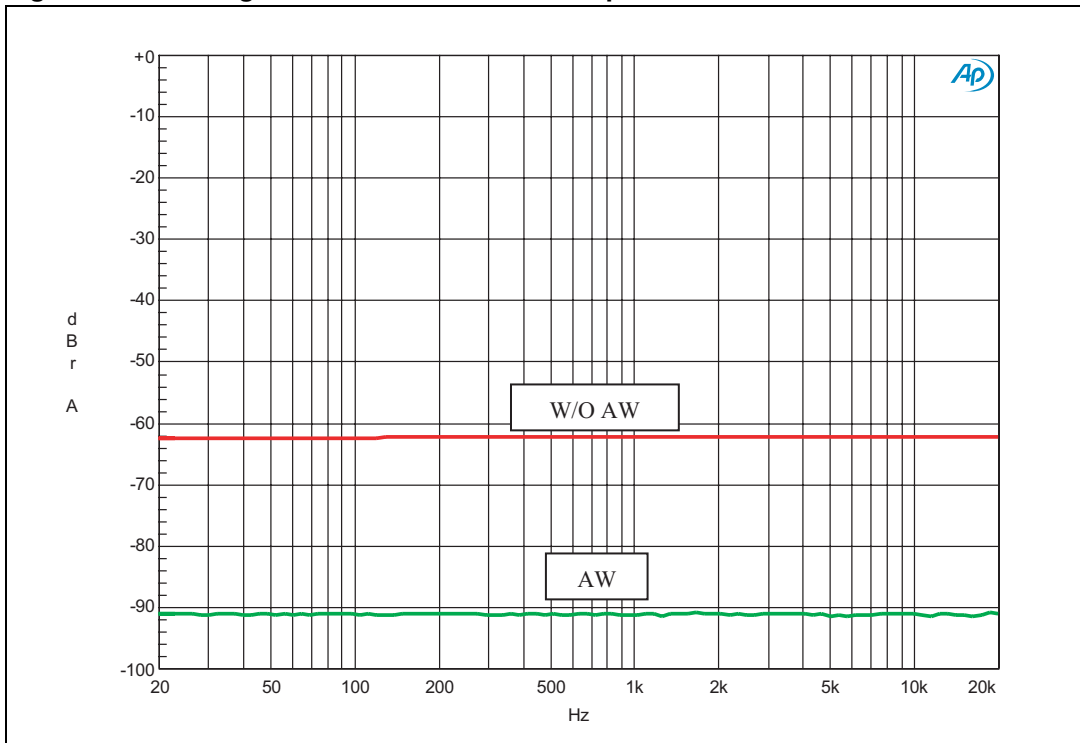

Figure 26. FFT 1 kHz, 0 dB at 1 W output

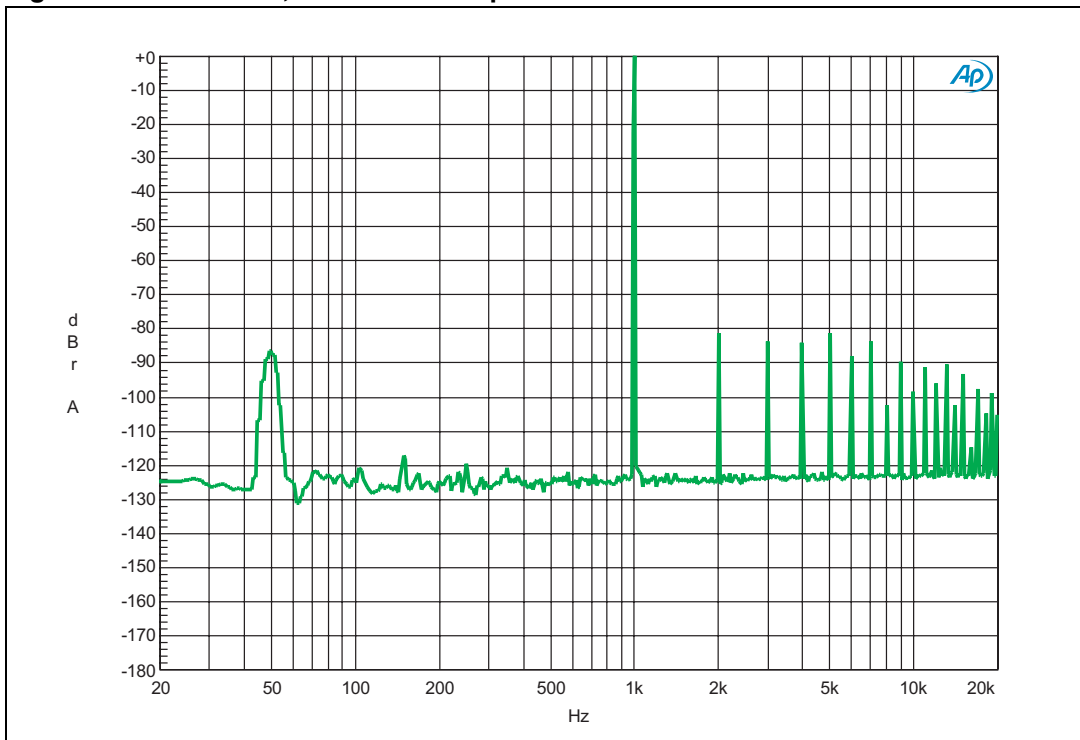

Figure 27. FFT 1 kHz, -60 dB at 1 W output

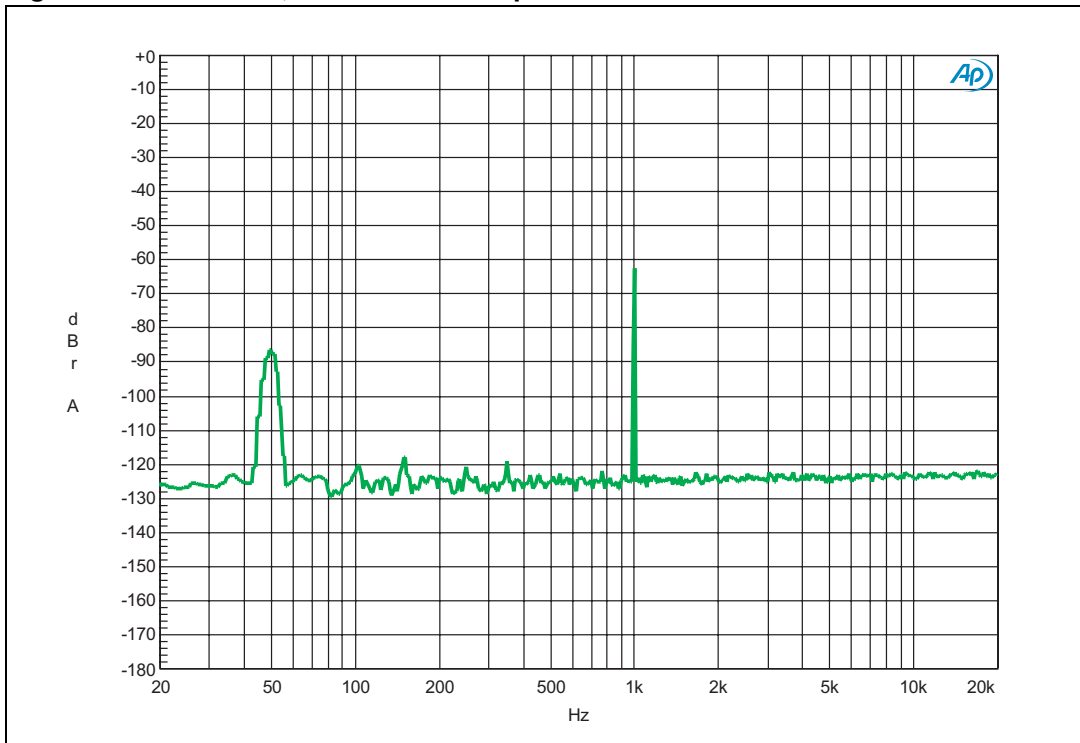
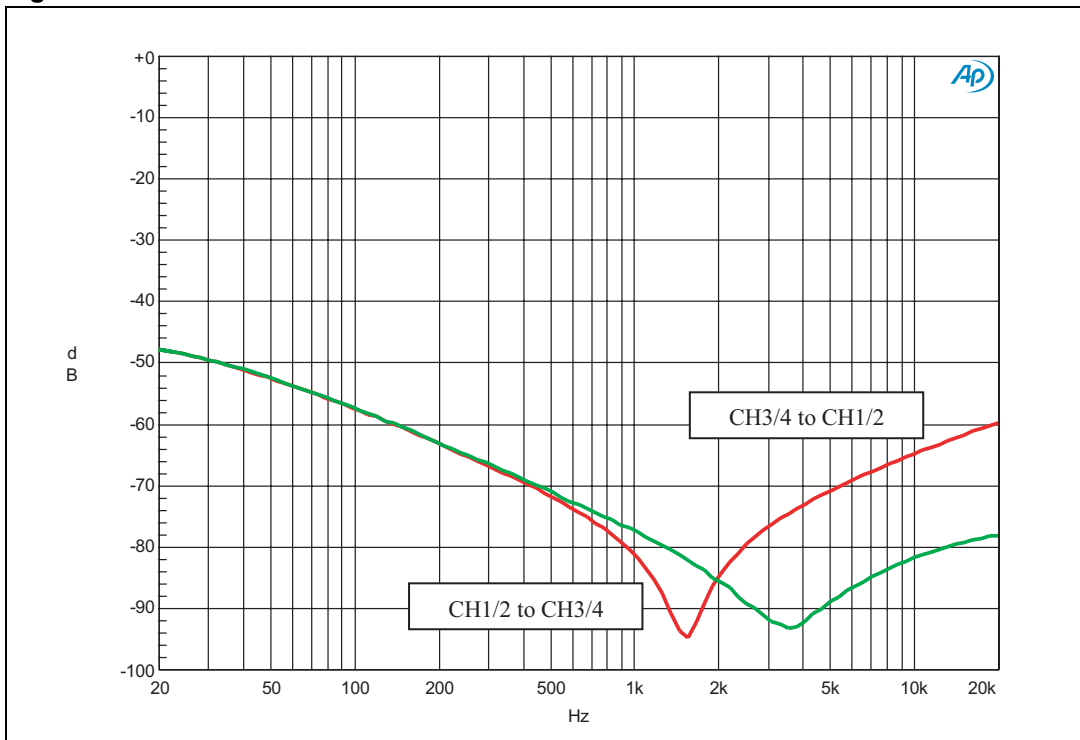

Figure 28. BTL Xtalk



## 5 Thermal information

### 5.1 Calculating power dissipation

For SE configuration, the equation for power dissipation is:

$$P_{dmax} = \frac{V_{CC}^2}{2\pi^2 RL}$$

For BTL configuration, the equation for power dissipation is:

$$P_{dmax} = \frac{2V_{CC}^2}{\pi^2 RL}$$

For example, for a 2.1-channel output configuration, when  $V_{CC}$  is 14.4 V, 2 single-ended channel loads are 4 ohm, and 1 BTL channel load is 8 ohm, the maximum power dissipation in the STA540SAN is:

$$P_{dmax} = 2 \times \left( \frac{V_{CC}^2}{2\pi^2 RL} \right) + \frac{2V_{CC}^2}{\pi^2 RL}$$

$$P_{dmax} = 2 \times \left( \frac{14.4^2}{2 \times 3.14^2 \times 4} \right) + \left( 2 \times \frac{14.4^2}{3.14^2 \times 8} \right)$$

$$P_{dmax} = 5.26 + 5.26 = 10.52 W$$

### 5.2 Selecting the heatsink

According to the STA540SAN datasheet, the thermal impedance between junction and case is 4.5 °C/W, the thermal muting threshold is 150 °C, when ambient temperature is 50 °C. To avoid thermal protection intervention, the heatsink thermal impedance should be:

$$R_{th\_heatsink} = \left( \frac{150 - 50}{Pd} \right) - R_{th-j\_case}$$

Based on the above condition, the minimum heatsink thermal impedance is:

$$R_{th\_heatsink} = \left( \frac{100}{10.52} \right) - 4.5 = 5^\circ C/W$$

When the average music listening power concept is considered, dissipation power is 60% of max dissipation power, thus the heatsink can be smaller. Therefore, the heatsink thermal impedance is:

$$R_{th\_heatsink} = \left( \frac{100}{10.52 \times 0.6} \right) - 4.5 = 11.34^\circ C/W$$

## 6 Revision history

**Table 2. Document revision history**

Date	Revision	Changes
12-Feb-2013	1	Initial release.

**Please Read Carefully:**

Information in this document is provided solely in connection with ST products. STMicroelectronics NV and its subsidiaries ("ST") reserve the right to make changes, corrections, modifications or improvements, to this document, and the products and services described herein at any time, without notice.

All ST products are sold pursuant to ST's terms and conditions of sale.

Purchasers are solely responsible for the choice, selection and use of the ST products and services described herein, and ST assumes no liability whatsoever relating to the choice, selection or use of the ST products and services described herein.

No license, express or implied, by estoppel or otherwise, to any intellectual property rights is granted under this document. If any part of this document refers to any third party products or services it shall not be deemed a license grant by ST for the use of such third party products or services, or any intellectual property contained therein or considered as a warranty covering the use in any manner whatsoever of such third party products or services or any intellectual property contained therein.

**UNLESS OTHERWISE SET FORTH IN ST'S TERMS AND CONDITIONS OF SALE ST DISCLAIMS ANY EXPRESS OR IMPLIED WARRANTY WITH RESPECT TO THE USE AND/OR SALE OF ST PRODUCTS INCLUDING WITHOUT LIMITATION IMPLIED WARRANTIES OF MERCHANTABILITY, FITNESS FOR A PARTICULAR PURPOSE (AND THEIR EQUIVALENTS UNDER THE LAWS OF ANY JURISDICTION), OR INFRINGEMENT OF ANY PATENT, COPYRIGHT OR OTHER INTELLECTUAL PROPERTY RIGHT.**

**UNLESS EXPRESSLY APPROVED IN WRITING BY TWO AUTHORIZED ST REPRESENTATIVES, ST PRODUCTS ARE NOT RECOMMENDED, AUTHORIZED OR WARRANTED FOR USE IN MILITARY, AIR CRAFT, SPACE, LIFE SAVING, OR LIFE SUSTAINING APPLICATIONS, NOR IN PRODUCTS OR SYSTEMS WHERE FAILURE OR MALFUNCTION MAY RESULT IN PERSONAL INJURY, DEATH, OR SEVERE PROPERTY OR ENVIRONMENTAL DAMAGE. ST PRODUCTS WHICH ARE NOT SPECIFIED AS "AUTOMOTIVE GRADE" MAY ONLY BE USED IN AUTOMOTIVE APPLICATIONS AT USER'S OWN RISK.**

Resale of ST products with provisions different from the statements and/or technical features set forth in this document shall immediately void any warranty granted by ST for the ST product or service described herein and shall not create or extend in any manner whatsoever, any liability of ST.

ST and the ST logo are trademarks or registered trademarks of ST in various countries.

Information in this document supersedes and replaces all information previously supplied.

The ST logo is a registered trademark of STMicroelectronics. All other names are the property of their respective owners.

© 2013 STMicroelectronics - All rights reserved

STMicroelectronics group of companies

Australia - Belgium - Brazil - Canada - China - Czech Republic - Finland - France - Germany - Hong Kong - India - Israel - Italy - Japan - Malaysia - Malta - Morocco - Philippines - Singapore - Spain - Sweden - Switzerland - United Kingdom - United States of America

[www.st.com](http://www.st.com)