



Chipsmall Limited consists of a professional team with an average of over 10 year of expertise in the distribution of electronic components. Based in Hongkong, we have already established firm and mutual-benefit business relationships with customers from,Europe,America and south Asia,supplying obsolete and hard-to-find components to meet their specific needs.

With the principle of “Quality Parts,Customers Priority,Honest Operation,and Considerate Service”,our business mainly focus on the distribution of electronic components. Line cards we deal with include Microchip,ALPS,ROHM,Xilinx,Pulse,ON,Everlight and Freescale. Main products comprise IC,Modules,Potentiometer,IC Socket,Relay,Connector.Our parts cover such applications as commercial,industrial, and automotives areas.

We are looking forward to setting up business relationship with you and hope to provide you with the best service and solution. Let us make a better world for our industry!



Contact us

Tel: +86-755-8981 8866 Fax: +86-755-8427 6832

Email & Skype: info@chipsmall.com Web: www.chipsmall.com

Address: A1208, Overseas Decoration Building, #122 Zhenhua RD., Futian, Shenzhen, China



STEVAL-CCA057V1 evaluation board user guidelines for dual operational amplifiers in an SO8 package

By Nicolas Aupetit

Introduction

The STEVAL-CCA057V1 evaluation board from STMicroelectronics is designed to help customers quickly prototype new dual op amp circuits in an SO8 package and reduce design time.

The evaluation board can be used with almost any STMicroelectronics dual op amp in various configurations and applications. The evaluation board is a bare board (that is, there are no components or amplifier soldered to the board; these must be ordered separately).

This document provides:

- A description of the evaluation board
- A layout of the top and bottom layers
- Some examples of classic configurations that can be tested with the board

Figure 1. SO8 pinout

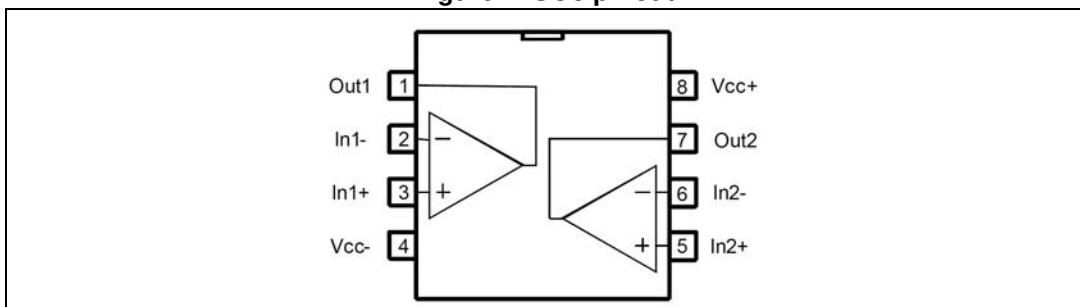
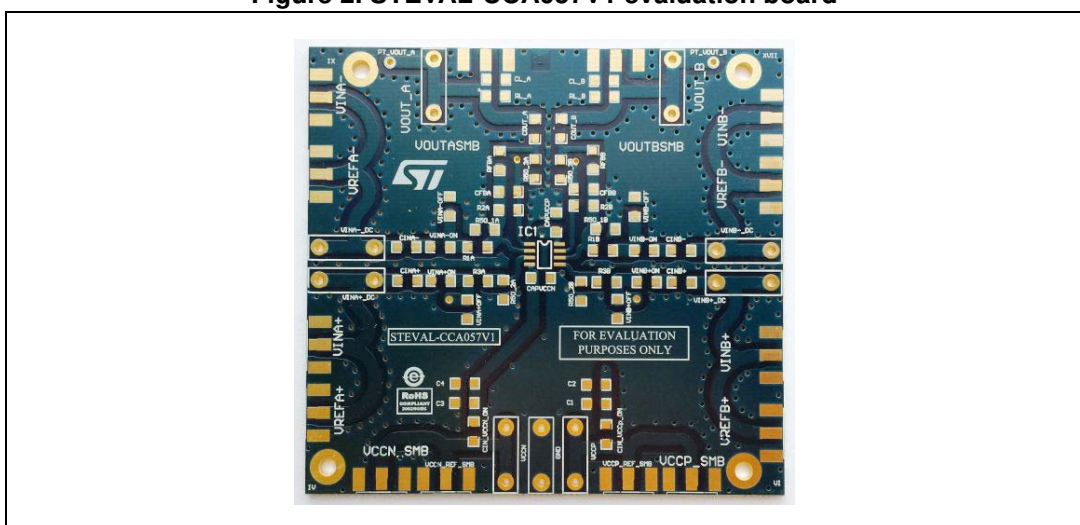

Figure 2. STEVAL-CCA057V1 evaluation board



Contents

1	Description	3
2	Layout	6
3	Different possible configurations	7
3.1	Low-pass Sallen-key configuration	7
3.2	High-pass Sallen-key configuration	8
3.3	Instrumentation amplifier	9
3.4	Transimpedance configuration	11
3.5	AC coupled circuit configuration	12
4	Associated products	13
5	Revision history	17

1 Description

This board is designed with versatility in mind, and allows many circuits to be constructed easily and quickly.

A few possible circuits are as follows:

- Voltage follower
- Non-inverting amplifier
- Inverting amplifier
- Sallen-key filter
- Instrument amplifier
- AC-coupled circuit
- Out-of-loop compensation circuit

Circuit

The circuit schematic in [Figure 3](#) shows the connections for all possible components. Each configuration uses only some of the components.

The board is designed for surface-mounted components and can be used to perform on-board characterization prior to the integration of STMicroelectronics products in your designs. Resistor and capacitor footprints are implemented for the 1206 series.

Figure 3. Evaluation board schematics

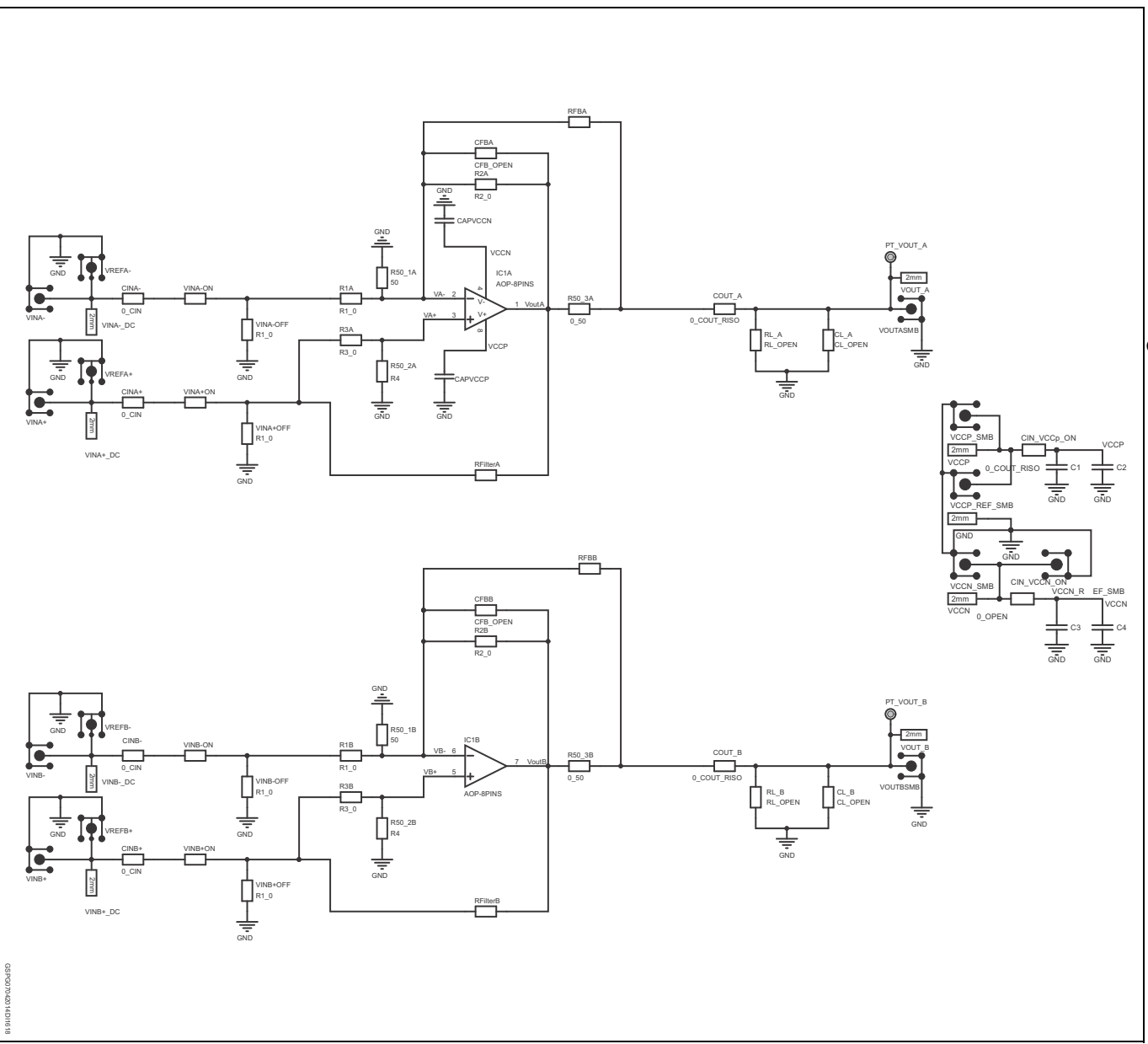

Power requirements

A 0 Ω resistance must be connecting on CIN_VCCN_ON and CIN_VCCP_ON in order to supply power to the dual amplifier.

A set of two decoupling capacitors (C1, C2 and C3, C4) have been implemented on both power supply pins, so as to benefit from the maximum performance of ST products. In order to reject low frequencies, 1 μF and 10 μF are good values for these.

Others decoupling capacitors (CAPVCCN, CAPVCCP) as close as possible to the SO8 package, might also be used to obtain excellent power supply decoupling. 100 pF values can be used in order to reject high frequencies.

When using single-supply circuits, the negative supply is shorted to ground by bridging C3 or C4 capacitances. Power is therefore between VCCP and GND.

Output options

The outputs have additional resistor (RL_A, RL_B) and capacitor (CL_A, CL_B) placements for loading. Or it might be used as an anti-alias filter, or to limit amplifier output noise by reducing its output bandwidth.

Note: Operational amplifiers are sensitive to output capacitance and may oscillate. In the event of oscillation, reduce output capacitance by using shorter cables, or add a resistor in series on COUT_A, COUT_B placement with a suitable value in order to improve amplifier phase margin.

Measurement tips

In the datasheet, some measurements, such as settling time and peaking, have been performed with 50 Ω output equipment. In order to keep the integrity of the square input signal, the input tracks from VINA+, VINB+, VINA-, VINB-, have an impedance of 50 Ω .

And in order to adapt input impedance, 50 Ω resistances can be added on the R50_1A, R50_2A and R50_1B, R50_2B.

2 Layout

The board has the following physical characteristics:

- Board dimensions: 3526 x 3300 mils (89.6 x 83.8 mm)
- 2-layer PCB
- Both sides have a ground plane.
- For Vout_A, Vout_B, VinA+, VinA-, VinB+ and VinB- female SMB or female 2 mm connectors can be implanted. You can also implant test points on these voltages. They will facilitate the visualization of your signals.

Top and bottom layers are shown on [Figure 4](#) and [Figure 5](#):

Figure 4. Top layer

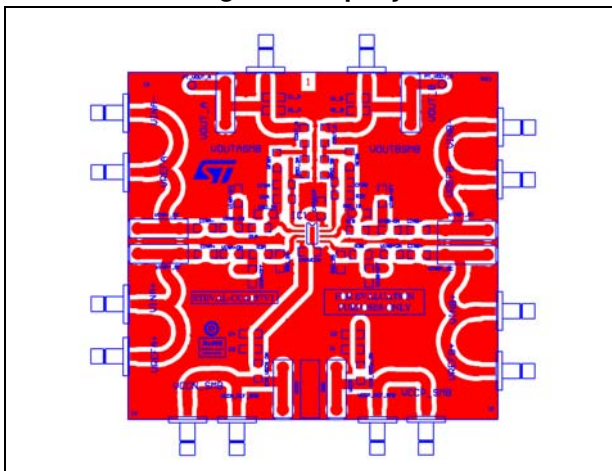
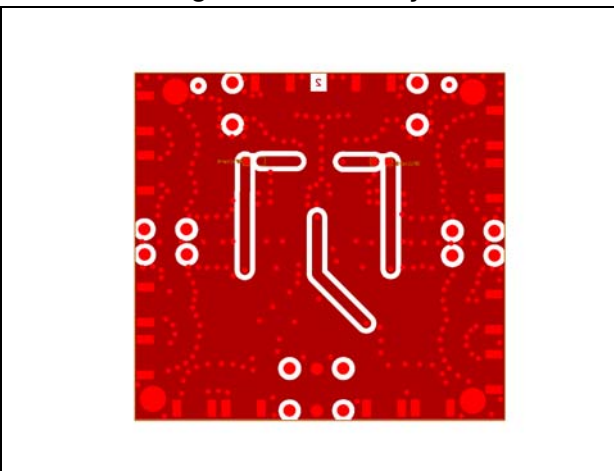

Figure 5. Bottom layer



3 Different possible configurations

The following provides some instructions on how to set up the board in order to perform several classical configurations.

- [Figure 6](#): Low-pass Sallen-key filter order 4
- [Figure 7](#): High-pass Sallen-key filter order 4
- [Figure 8](#): Instrumentation amplifier
- [Figure 9](#): Transimpedance configuration
- [Figure 10](#): AC coupled configuration

You can also put several boards in cascade which allows you to obtain a more complex configurations.

3.1 Low-pass Sallen-key configuration

The following low-pass Sallen-key configuration is a fourth order filter configuration. This circuit has 80 dB roll-off per decade.

The transfer function is:

Equation 1

$$\frac{V_{out}}{V_{in}} = \frac{1 + \frac{RFA}{RGA}}{1 + \left(R1.C2 \left(1 - \frac{RFA}{RGA} \right) + C1(R1+R2) \right) j\omega + R1.R2.C1.C2(j\omega)^2} * \frac{1 + \frac{RFB}{RGB}}{1 + \left(R3.C4 \left(1 - \frac{RFB}{RGB} \right) + C3(R3+R4) \right) j\omega + R3.R4.C3.C4(j\omega)^2}$$

The low frequency gain is:

Equation 2

$$G = \left(1 + \frac{RFA}{RGA} \right) * \left(1 + \frac{RFB}{RGB} \right)$$

Figure 6. Low-pass Sallen-key 4th order configuration

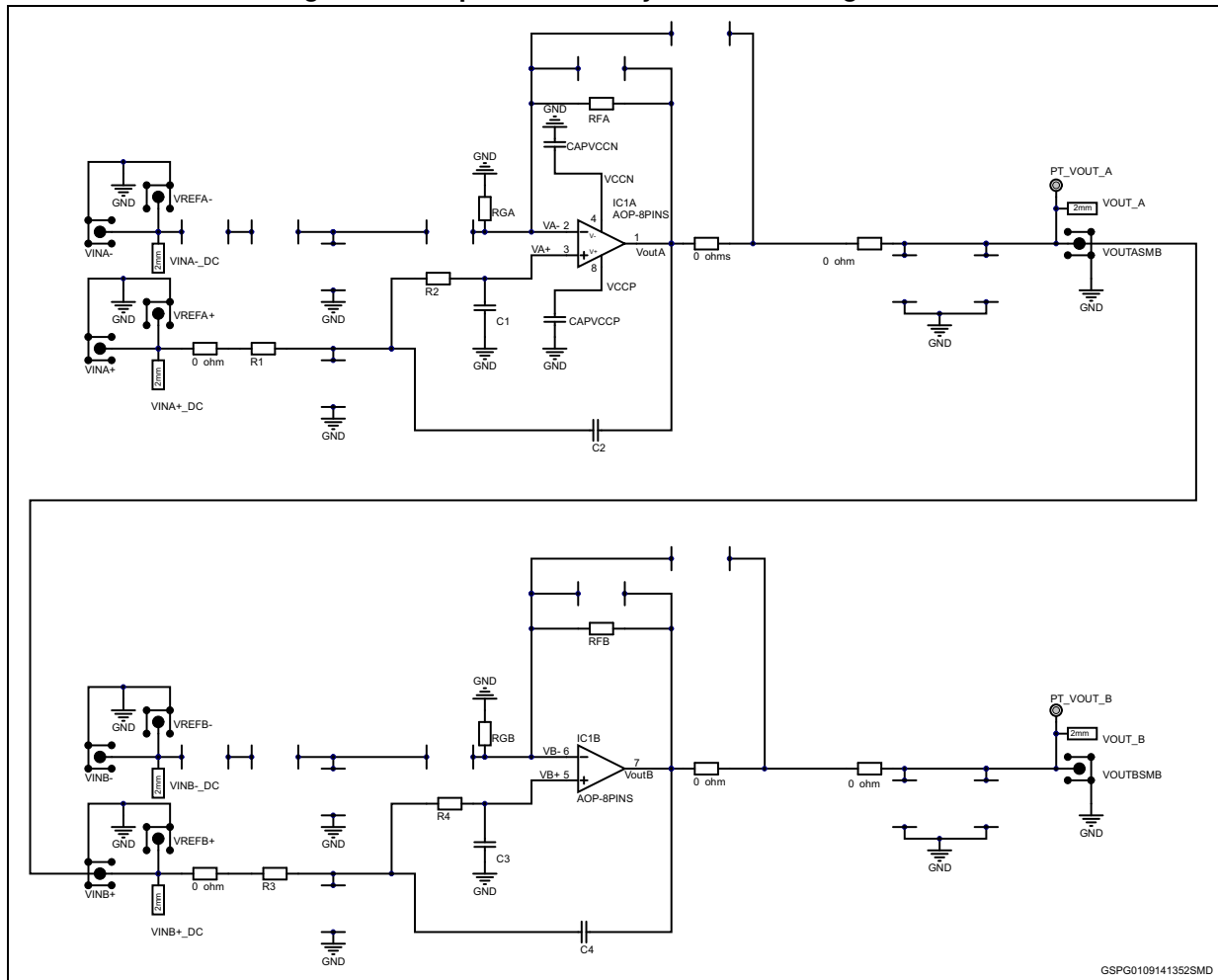

3.2 High-pass Sallen-key configuration

Like the low-pass Sallen-key configuration above, this one is also a fourth order. It has a slope of +80 dB per decade.

The transfer function is:

Equation 3

$$\frac{v_{out}}{v_{in}} = \frac{\left(1 + \frac{RFA}{RGA}\right) R1.R2.C1.C2.(j\omega)^2}{1 + \left(R2(C1+C2) - R1.C2 \frac{RFA}{RGA}\right) j\omega + R1.R2.C1.C2.(j\omega)^2} * \frac{\left(1 + \frac{RFB}{RGB}\right) R3.R4.C3.C4.(j\omega)^2}{1 + \left(R4(C3+C4) - R3.C4 \frac{RFB}{RGB}\right) j\omega + R3.R4.C3.C4.(j\omega)^2}$$

The high frequency gain is:

Equation 4

$$G = \left(1 + \frac{RFA}{RGA}\right) * \left(1 + \frac{RFB}{RGB}\right)$$

Figure 7. High-pass Sallen-key configuration

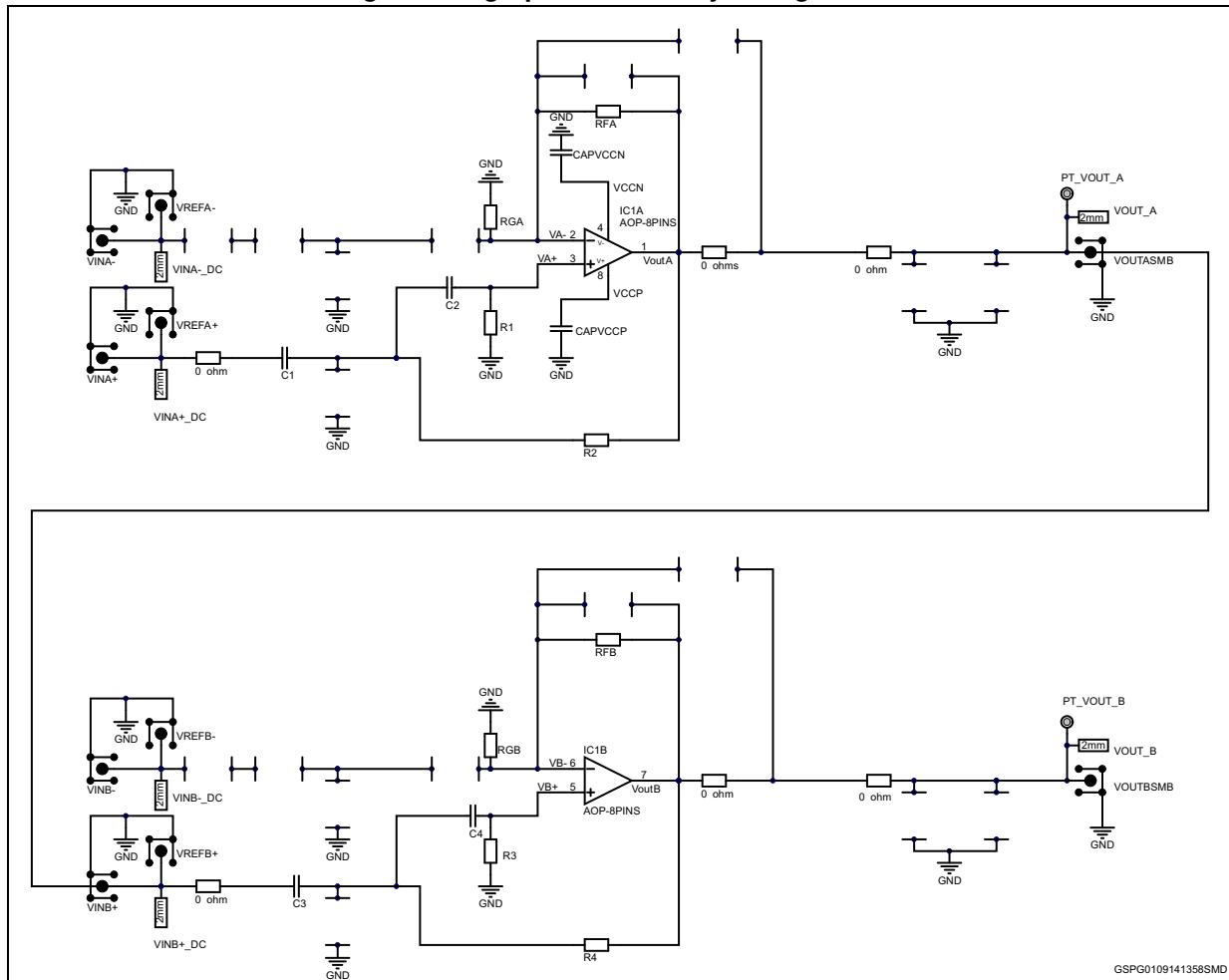

The upper limit of the frequency range is determined by the GBP of the op amp ($F \ll \frac{GBP}{1 + \frac{RFB}{RFA}}$)

3.3 Instrumentation amplifier

The instrumentation amplifiers are generally used for precise measurement in a differential way.

The architecture of the instrumentation amplifier with dual op amps is the simplest one. The input impedance is high as the non-inverting of the both op amps are used as input.

By considering $R1.R2 = RFA.RFB$

And $Vout = Vreference$ for $Vdiff = 0 V$

The gain can be expressed as follows:

Equation 5

$$G = 1 + \frac{RFB}{Rg} + \frac{R1}{Rg} + \frac{R1}{RFA}$$

Figure 8. Instrumentation amplifier

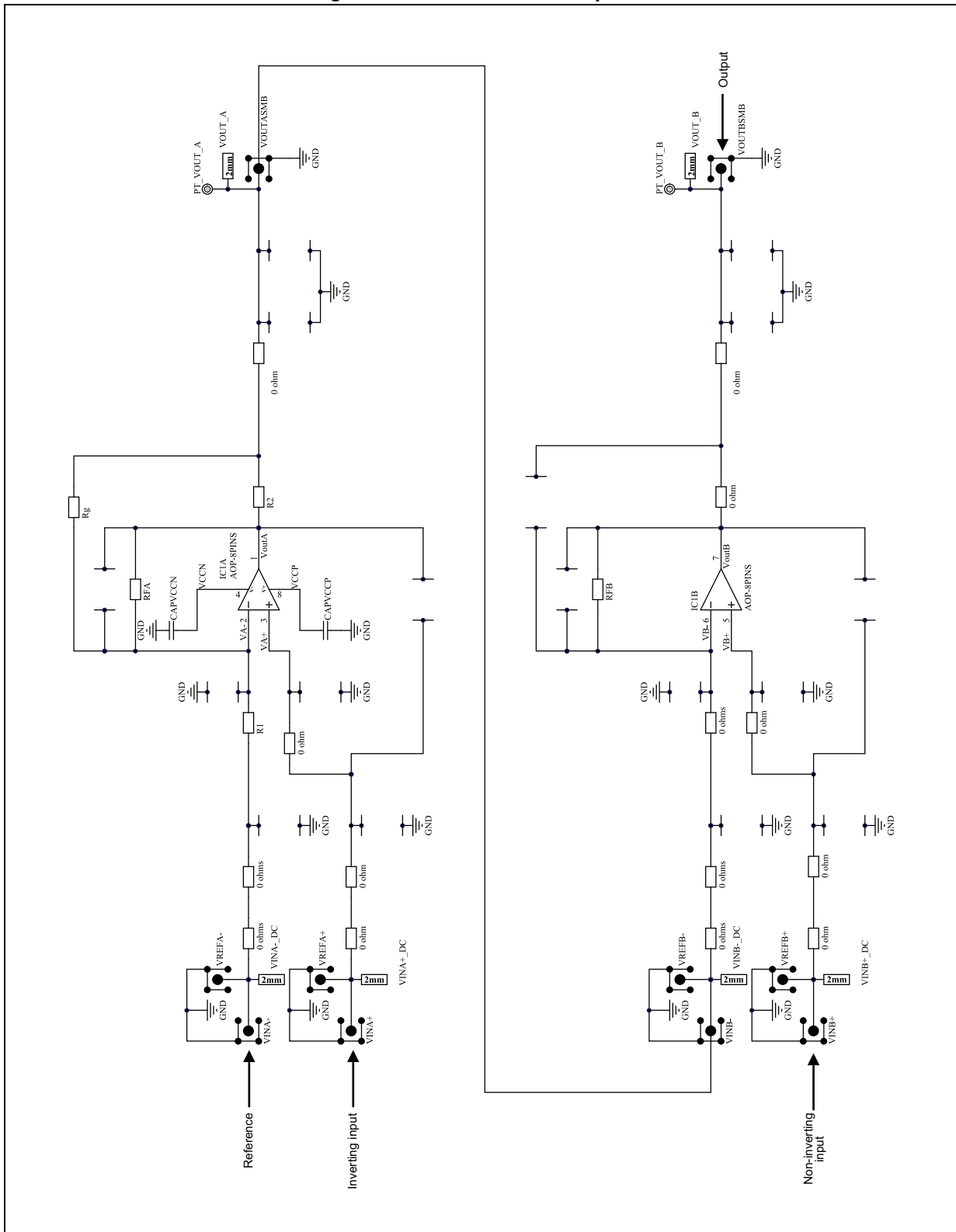

3.4 Transimpedance configuration

The *Figure 9* shows how to configure op amp IC1A as a transimpedance amplifier (TIA). The output voltage of the TIA is the input current multiplied by the feedback resistor RFA:

Equation 6

$$VOUT_A = (I_{in} + I_{bias}) * RFA - V_{os}$$

where I_{in} is defined as the input current source applied at the VINA- pad, I_{BIAS} is the input bias current, and V_{OS} is the input offset voltage of the op amp. For the type of usage, the feedback resistor RFA is generally high and the impedance seen on the VA- node is pretty capacitive (ex: photodiode). In order to stabilize the op amp it is recommended to connect a feedback capacitance CF.

Figure 9. Transimpedance configuration

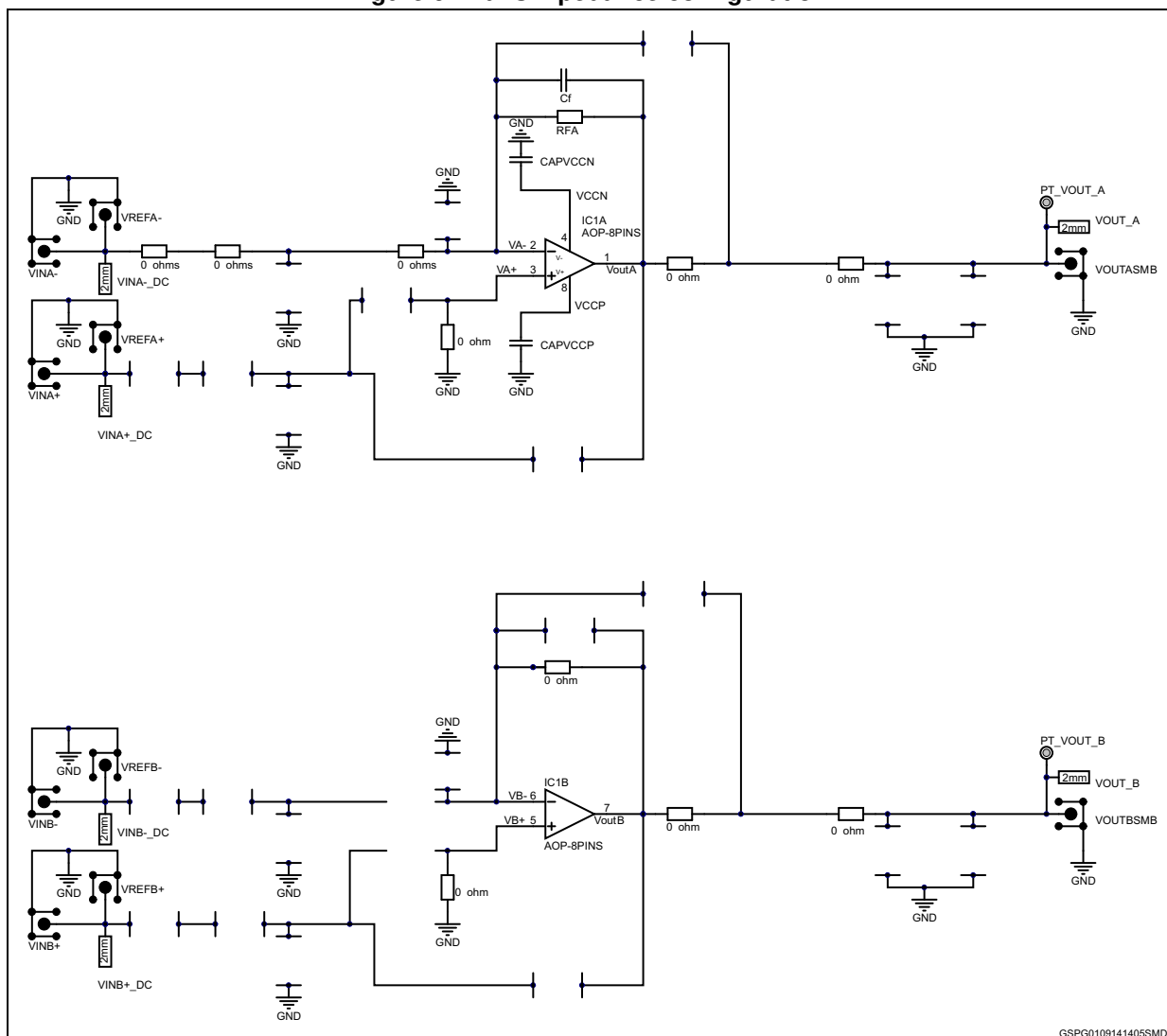

Note: If only IC1A op amp is used as transimpedance amplifier, the second one, IC1B, should be configured in follower mode in order to avoid any undesired oscillation on its output.

3.5 AC coupled circuit configuration

This typical configuration allows you to amplify the AC part of the input signal only; for example, a typical stereo audio amplifier.

Figure 10. AC coupled circuit configuration

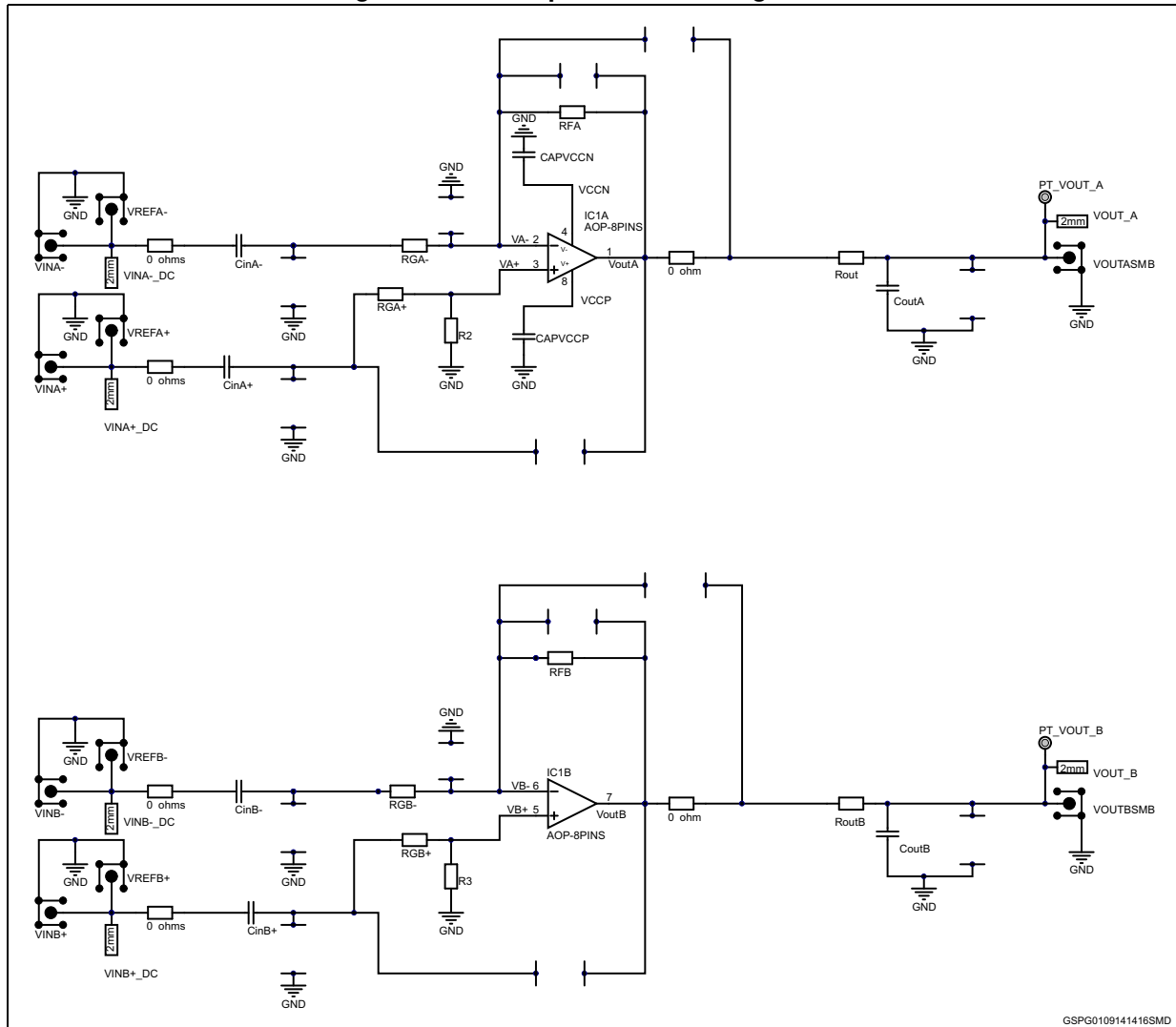

GSPG01091414165MD

4 Associated products

Table 1. Associated products

Part number	General description
LF351DT	JFET inputs, low input bias & offset current, (15nV/ $\sqrt{\text{Hz}}$ & 0.01%)
LF353DT	JFET inputs, low input bias & offset current, (15nV/ $\sqrt{\text{Hz}}$ & 0.01%)
LM301ADT	Input & output overload protection, low input offset current
LM358DT	Low-power dual op amps with low input bias current
TL072ADT	JFET inputs, low input bias current
TS461DT	Output rail-to-rail op amps
TS462DT	Output rail-to-rail op amps
TSH62DT	Wide band, low power operational amplifier with standby function
TSH71DT	Rail-to-rail video op amp with standby
TSH72DT	Rail-to-rail video op amp
TS613IDT	ADSL line driver
TS931IDT	Micropower amplifier with CMOS inputs
TS932IDT	Micropower amplifier with CMOS inputs
TS941IDT	Ultra-micropower amplifier with CMOS inputs
TS942IDT	Ultra-micropower amplifier with CMOS inputs
TS942AIDT	Ultra-micropower amplifier with CMOS inputs
TSH80IDT	Rail-to-rail video op amp with standby
TSH82IDT	Rail-to-rail video op amp
TSV612IDT	Rail to rail input/output CMOS op amp
TSV612AIDT	Rail to rail input/output CMOS op amp
TSV6192IDT	Rail to rail input/output CMOS op amp
TSV6192AIDT	Rail to rail input/output CMOS op amp
LF253IDT	JFET inputs, low input bias & offset current, (15nV/ $\sqrt{\text{Hz}}$ & 0.01%)
LM201AIDT	Input & output overload protection, low input offset current
LM258IDT	Low-power dual op amps with low input bias current
LM258WIDT	Low power dual operational amplifiers
LS204IDT	Low-noise bipolar op amps
MC1458IDT	High performance dual op amps with wide input common-mode voltage range
MC33078IDT	Low-noise op amps
MC33171IDT	Low consumption versus speed
MC4558IDT	Wide bandwidth dual bipolar op amps

Table 1. Associated products (continued)

Part number	General description
TL061IDT	JFET inputs, low input bias current
TL062IDT	JFET inputs, low input bias current
TL062AIDT	JFET inputs, low input bias current
TL062BIDT	JFET inputs, low input bias current
TL071IDT	JFET inputs, low input bias current
TL072IDT	JFET inputs, low input bias current
TL072BIDT	JFET inputs, low input bias current
TL081IDT	JFET inputs, low input bias current
TL082IDT	JFET inputs, low input bias current
UA741IDT	Wide applications range
UA748IDT	Wide applications range
LM158IDT	Low power dual op amps with low input bias current
LM158WIDT	Low power dual operational amplifiers
LM2904IDT	Low power, bipolar op amp
LM2904AIDT	Low power, bipolar op amp
LM2904WIDT	Low power dual operational amplifier
LM833IDT	Low-noise dual op amps amplifier
LMV358IDT	Low cost low power rail-to-rail input/output op amp
LMV358LIDT	Low-power, general-purpose operational amplifier op amp
LMV822IDT	Low power, high accuracy, general purpose operational amplifier
LMV822AIDT	Low power, high accuracy, general purpose operational amplifier
LMX358IDT	Low-power, general-purpose operational amplifier
MC33172IDT	Low consumption versus speed
TJM4558IDT	Wide bandwidth dual bipolar op amps
TS1851IDT	1.8V min. voltage supply, micropower
TS1852IDT	1.8V min. voltage supply, micropower
TS1852AIDT	1.8V min. voltage supply, micropower
TS1871IDT	1.8V input/output rail-to-rail low power operational amplifiers
TS1872IDT	1.8V min. voltage supply, micropower
TS1872AIDT	1.8V min. voltage supply, micropower
TS271IDT	Micropower, programmable op amp
TS272IDT	Micropower, wide range of input offset voltage
TS27L2IDT	Micropower, high voltage CMOS op amp
TS27M2IDT	Micropower, high voltage CMOS op amp
TS27M2AIDT	Micropower, high voltage CMOS op amp

Table 1. Associated products (continued)

Part number	General description
TS27M2BIDT	Micropower, high voltage CMOS op amp
TS507IDT	High precision single supply rail to rail op amp
TS512IDT	Precision op amps
TS512AIDT	Low noise & distortion (8nV/√Hz & 0.03%)
TS522IDT	Precision low-noise dual op amps
TS912IDT	Low power with CMOS inputs
TS912AIDT	Low power with CMOS inputs
TS912BIDT	Low power with CMOS inputs
TS921IDT	Rail-to-rail high output current op amps
TS922IDT	Excellent audio performance / low distortion (0.005%)
TS9222IDT	Precision rail-to-rail high output current op amps
TS922AIDT	Excellent audio performance / low distortion (0.005%)
TS951IDT	Real input & output rail to rail / low distortion (0.01%)
TS952IDT	Real input & output rail to rail / low distortion (0.01%)
TS971IDT	Output rail-to-rail very low-noise op amps
TS972IDT	Output rail-to-rail very low-noise op amps
TSH22IDT	High gain bandwidth product bipolar op amp
TSV358IDT	General purpose low voltage rail to rail input/output op amp
TSV622IDT	Micro-power CMOS op amp
TSV622AIDT	Micro-power CMOS op amp
TSV6292IDT	Micro-power CMOS op amp
TSV6292AIDT	Micro-power CMOS op amp
TSV632IDT	Micro-power CMOS op amp
TSV632AIDT	Micro-power CMOS op amp
TSV6392IDT	Micro-power CMOS op amp
TSV6392AIDT	Micro-power CMOS op amp
TSV852IDT	Low-power, high accuracy, general-purpose operational amplifier
TSV852AIDT	Low-power, high accuracy, general-purpose operational amplifier
TSV911IDT	Rail to rail input/output wide bandwidth op amps
TSV911AIDT	Rail to rail input/output wide bandwidth op amps
TSV912IDT	Rail to rail input/output wide bandwidth op amps
TSV912AIDT	Rail to rail input/output wide bandwidth op amps
TSV991IDT	Rail to rail input/output high merit factor op amps
TSV991AIDT	Rail to rail input/output high merit factor op amps
TSV992IDT	Rail to rail input/output high merit factor op amps

Table 1. Associated products (continued)

Part number	General description
TSV992AIDT	Rail to rail input/output high merit factor op amps
TSX562IDT	Micropower, wide bandwidth 16V CMOS op amps
TSX562AIDT	Micropower, wide bandwidth 16V CMOS op amps
TSX922IDT	10MHz, rail-to-rail 16V CMOS op amps
TSX9292IDT	16MHz, rail-to-rail 16V CMOS op amps
TSZ122IDT	Very high accuracy (5 μ V) zero drift micropower 5 V
LM2904WHIDT	Dual general purpose operational amplifier
TSV912HIDT	High temperature rail to rail input/output wide bandwidth op amps

5 Revision history

Table 2. Document revision history

Date	Revision	Changes
03-Sep-2014	1	Initial release.

IMPORTANT NOTICE – PLEASE READ CAREFULLY

STMicroelectronics NV and its subsidiaries ("ST") reserve the right to make changes, corrections, enhancements, modifications, and improvements to ST products and/or to this document at any time without notice. Purchasers should obtain the latest relevant information on ST products before placing orders. ST products are sold pursuant to ST's terms and conditions of sale in place at the time of order acknowledgement.

Purchasers are solely responsible for the choice, selection, and use of ST products and ST assumes no liability for application assistance or the design of Purchasers' products.

No license, express or implied, to any intellectual property right is granted by ST herein.

Resale of ST products with provisions different from the information set forth herein shall void any warranty granted by ST for such product.

ST and the ST logo are trademarks of ST. All other product or service names are the property of their respective owners.

Information in this document supersedes and replaces information previously supplied in any prior versions of this document.

© 2014 STMicroelectronics – All rights reserved