



Chipsmall Limited consists of a professional team with an average of over 10 year of expertise in the distribution of electronic components. Based in Hongkong, we have already established firm and mutual-benefit business relationships with customers from,Europe,America and south Asia,supplying obsolete and hard-to-find components to meet their specific needs.

With the principle of “Quality Parts,Customers Priority,Honest Operation,and Considerate Service”,our business mainly focus on the distribution of electronic components. Line cards we deal with include Microchip,ALPS,ROHM,Xilinx,Pulse,ON,Everlight and Freescale. Main products comprise IC,Modules,Potentiometer,IC Socket,Relay,Connector.Our parts cover such applications as commercial,industrial, and automotives areas.

We are looking forward to setting up business relationship with you and hope to provide you with the best service and solution. Let us make a better world for our industry!



Contact us

Tel: +86-755-8981 8866 Fax: +86-755-8427 6832

Email & Skype: info@chipsmall.com Web: www.chipsmall.com

Address: A1208, Overseas Decoration Building, #122 Zhenhua RD., Futian, Shenzhen, China



Sub-1 GHz transceiver development kit based on S2-LP

Data brief

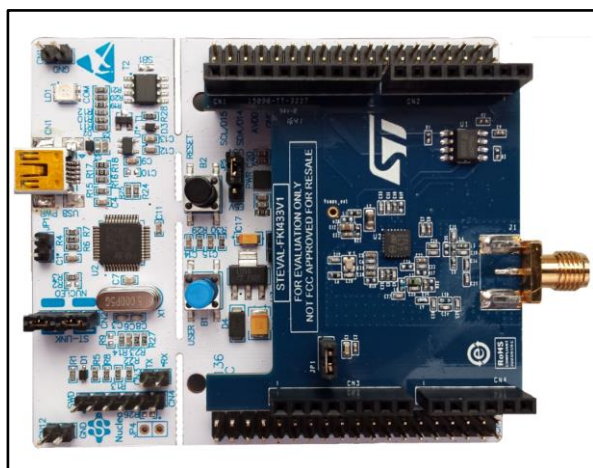

- RoHS compliant

Description

The STEVAL-FKI433V1 evaluation board is based on the S2-LP sub-1 GHz ultra-low power, low data-rate transceiver suitable for ISM bands and Wireless M-Bus.

The motherboard is the NUCLEO-L152RE board with STM32L low power microcontroller to control the S2-LP device and integrated ST-LINK/V2-1 debugger and programmer for firmware updating.

Features

- S2-LP narrow band ultra-low power sub-1 GHz transceiver in a standalone RF Module tuned for 430 - 470 MHz frequency bands
- STM32 Nucleo 64 development board with STM32L152RE MCU
- Suitable for Wireless M-Bus systems
- Associated S2-LP development kit including documentation, firmware for STM32L and GUI
- Programmable RF output power up to +16 dBm
- Modulation schemes: 2-FSK, 2-GFSK, 4-FSK, 4-GFSK, OOK, and ASK
- Air data rate from 0.3 to 500 kbps
- Ultra-low power consumption:
 - 6.7 mA RX
 - 10 mA TX @ +10 dBm
- Excellent performance of receiver sensitivity (up to -130 dBm)
- Low duty cycle RX / TX operation mode
- Automatic acknowledgement, retransmission and timeout protocol engine
- SPI interface for microcontroller
- USB interface

1 Schematic diagram

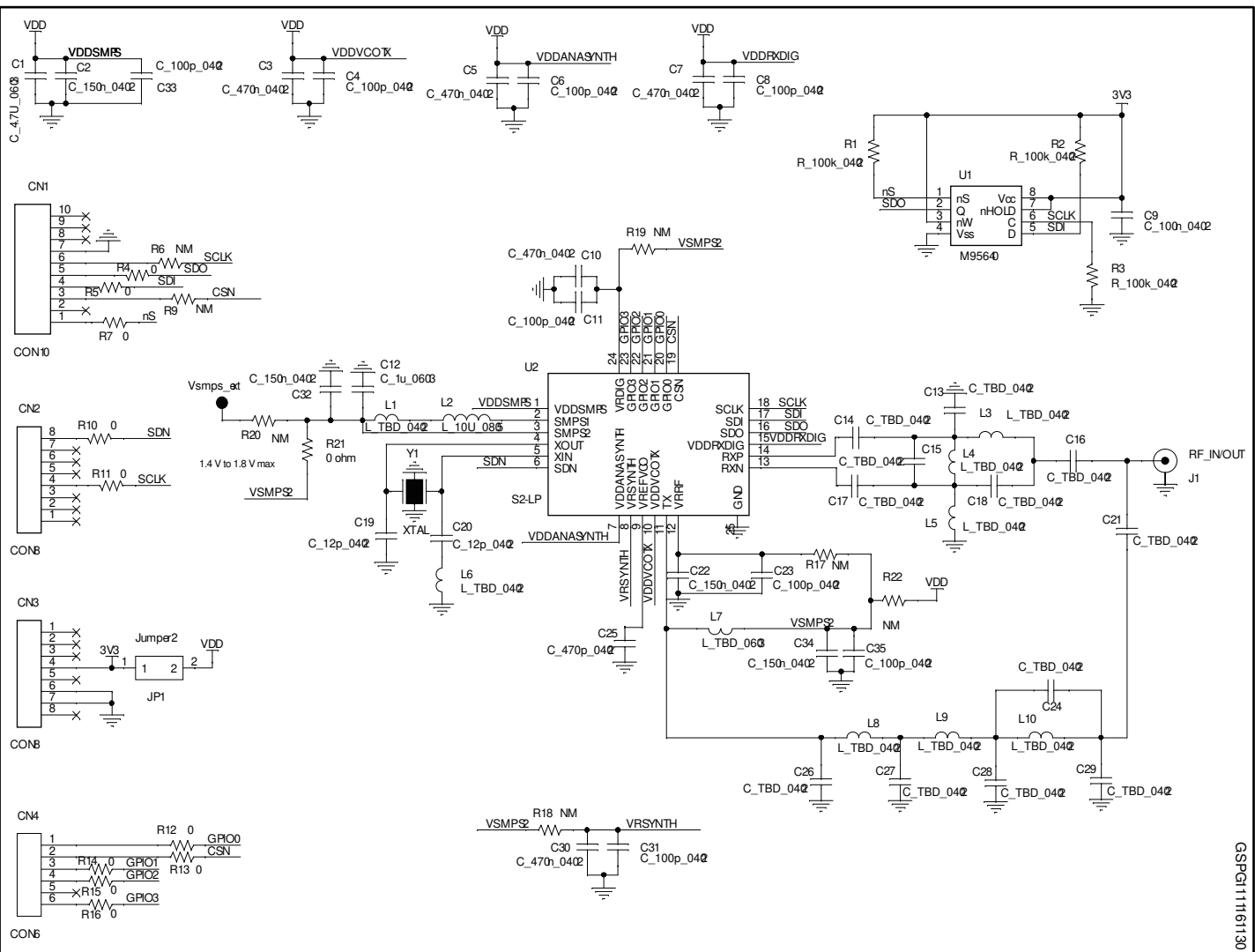

Figure 1: STEVAL-FK1433V1 circuit schematic

GSPG1116130



2 Revision history

Table 1: Document revision history

Date	Version	Changes
14-Nov-2016	1	Initial release.

IMPORTANT NOTICE – PLEASE READ CAREFULLY

STMicroelectronics NV and its subsidiaries ("ST") reserve the right to make changes, corrections, enhancements, modifications, and improvements to ST products and/or to this document at any time without notice. Purchasers should obtain the latest relevant information on ST products before placing orders. ST products are sold pursuant to ST's terms and conditions of sale in place at the time of order acknowledgement.

Purchasers are solely responsible for the choice, selection, and use of ST products and ST assumes no liability for application assistance or the design of Purchasers' products.

No license, express or implied, to any intellectual property right is granted by ST herein.

Resale of ST products with provisions different from the information set forth herein shall void any warranty granted by ST for such product.

ST and the ST logo are trademarks of ST. All other product or service names are the property of their respective owners.

Information in this document supersedes and replaces information previously supplied in any prior versions of this document.

© 2016 STMicroelectronics – All rights reserved