



Chipsmall Limited consists of a professional team with an average of over 10 year of expertise in the distribution of electronic components. Based in Hongkong, we have already established firm and mutual-benefit business relationships with customers from,Europe,America and south Asia,supplying obsolete and hard-to-find components to meet their specific needs.

With the principle of “Quality Parts,Customers Priority,Honest Operation,and Considerate Service”,our business mainly focus on the distribution of electronic components. Line cards we deal with include Microchip,ALPS,ROHM,Xilinx,Pulse,ON,Everlight and Freescale. Main products comprise IC,Modules,Potentiometer,IC Socket,Relay,Connector.Our parts cover such applications as commercial,industrial, and automotives areas.

We are looking forward to setting up business relationship with you and hope to provide you with the best service and solution. Let us make a better world for our industry!



Contact us

Tel: +86-755-8981 8866 Fax: +86-755-8427 6832

Email & Skype: info@chipsmall.com Web: www.chipsmall.com

Address: A1208, Overseas Decoration Building, #122 Zhenhua RD., Futian, Shenzhen, China



RF daughterboard platform based on BlueNRG-MS

Data brief

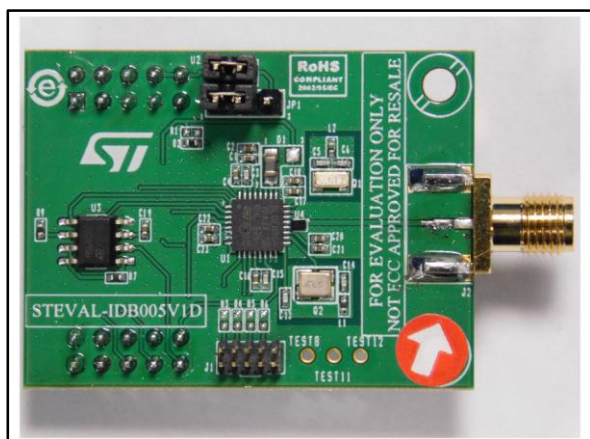

Description

The STEVAL-IDB005V1D is an RF daughterboard platform based on the BlueNRG-MS low power Bluetooth® Smart IC, compliant with the Bluetooth® 4.1 specifications and supporting both master and slave roles.

The STEVAL-IDB005V1D RF daughterboard features the BlueNRG-MS device, an SMA connector for antennas or measuring instruments and an SPI connector for an external microcontroller. It can be connected to STM32L motherboards available with the STEVAL-IDB002V1 and STEVAL-IDB005V1 platforms.

Features

- Bluetooth® SMART RF daughterboard based on the BlueNRG-MS low energy network processor
- Maximum transmission power +8 dBm
- Excellent receiver sensitivity (-88 dBm)
- Very low power consumption: 7.3 mA RX and 8.3 mA TX at +0 dBm
- Bluetooth® low energy 4.1 compliant, supports both master and slave roles
- RoHS compliant

1 Schematic diagram

Figure 1: STEVAL-IDB005V1D circuit schematic

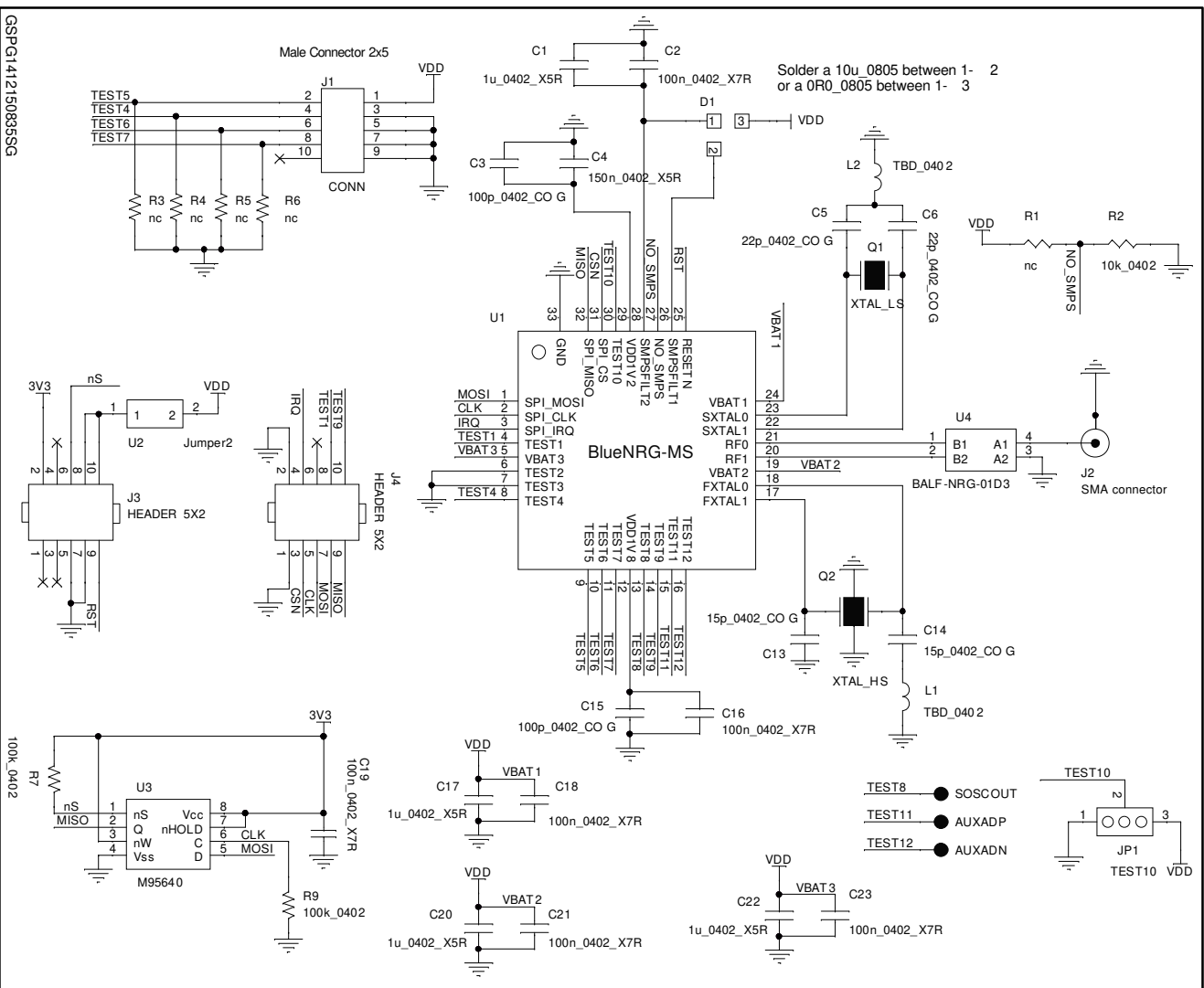

2 Revision history

Table 1: Document revision history

Date	Version	Changes
17-Dec-2015	1	Initial release.

IMPORTANT NOTICE – PLEASE READ CAREFULLY

STMicroelectronics NV and its subsidiaries ("ST") reserve the right to make changes, corrections, enhancements, modifications, and improvements to ST products and/or to this document at any time without notice. Purchasers should obtain the latest relevant information on ST products before placing orders. ST products are sold pursuant to ST's terms and conditions of sale in place at the time of order acknowledgement.

Purchasers are solely responsible for the choice, selection, and use of ST products and ST assumes no liability for application assistance or the design of Purchasers' products.

No license, express or implied, to any intellectual property right is granted by ST herein.

Resale of ST products with provisions different from the information set forth herein shall void any warranty granted by ST for such product.

ST and the ST logo are trademarks of ST. All other product or service names are the property of their respective owners.

Information in this document supersedes and replaces information previously supplied in any prior versions of this document.

© 2015 STMicroelectronics – All rights reserved