



Chipsmall Limited consists of a professional team with an average of over 10 year of expertise in the distribution of electronic components. Based in Hongkong, we have already established firm and mutual-benefit business relationships with customers from,Europe,America and south Asia,supplying obsolete and hard-to-find components to meet their specific needs.

With the principle of “Quality Parts,Customers Priority,Honest Operation,and Considerate Service”,our business mainly focus on the distribution of electronic components. Line cards we deal with include Microchip,ALPS,ROHM,Xilinx,Pulse,ON,Everlight and Freescale. Main products comprise IC,Modules,Potentiometer,IC Socket,Relay,Connector.Our parts cover such applications as commercial,industrial, and automotives areas.

We are looking forward to setting up business relationship with you and hope to provide you with the best service and solution. Let us make a better world for our industry!



Contact us

Tel: +86-755-8981 8866 Fax: +86-755-8427 6832

Email & Skype: info@chipsmall.com Web: www.chipsmall.com

Address: A1208, Overseas Decoration Building, #122 Zhenhua RD., Futian, Shenzhen, China



Evaluation platform based on the SPBTLE-1S module

Data brief

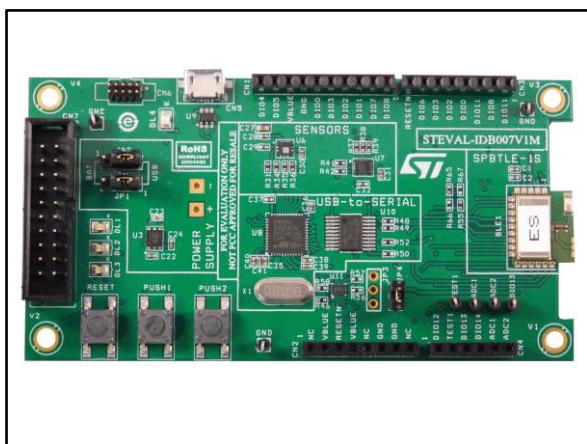

- 3D digital accelerometer and 3D digital gyroscope
- MEMS pressure sensor with embedded temperature sensor
- Battery holder
- JTAG debug connector
- USB to serial bridge for providing I/O channel with the BlueNRG-1 device
- Jumper for measuring current for BlueNRG-1 only
- RoHS compliant

Description

The STEVAL-IDB007V1M evaluation platform is based on the SPBTLE-1S, BlueNRG-1 SoC ICs, low power Bluetooth® smart system on chip, compliant with the Bluetooth® v4.2 specification and supporting master, slave and simultaneous master-and-slave roles.

The STEVAL-IDB007V1M also provides a set of hardware resources for a wide range of application scenarios: sensor data (accelerometer, pressure and temperature sensors), remote control (buttons and LEDs) and debug message management via USB virtual COM.

Three power options are available (USB only, battery only and external power supply + USB) for high application development and testing flexibility.

Features

- Bluetooth® SMART board with the SPBTLE-1S certified module based on the BlueNRG-1 Bluetooth low energy system-on-chip
- Associated BlueNRG-1 development kit SW package including firmware and documentation
- Up to +5 dBm available output power
- Bluetooth® low energy v4.2 compliant, supports master, slave and simultaneous master-and-slave roles
- Integrated balun which integrates a matching network and harmonics filter
- SMA connector for antenna or measuring equipment
- 3 user LEDs
- 2 user buttons

Schematic diagrams

Figure 1: STEVAL-IDB007V1M - arduino connectors

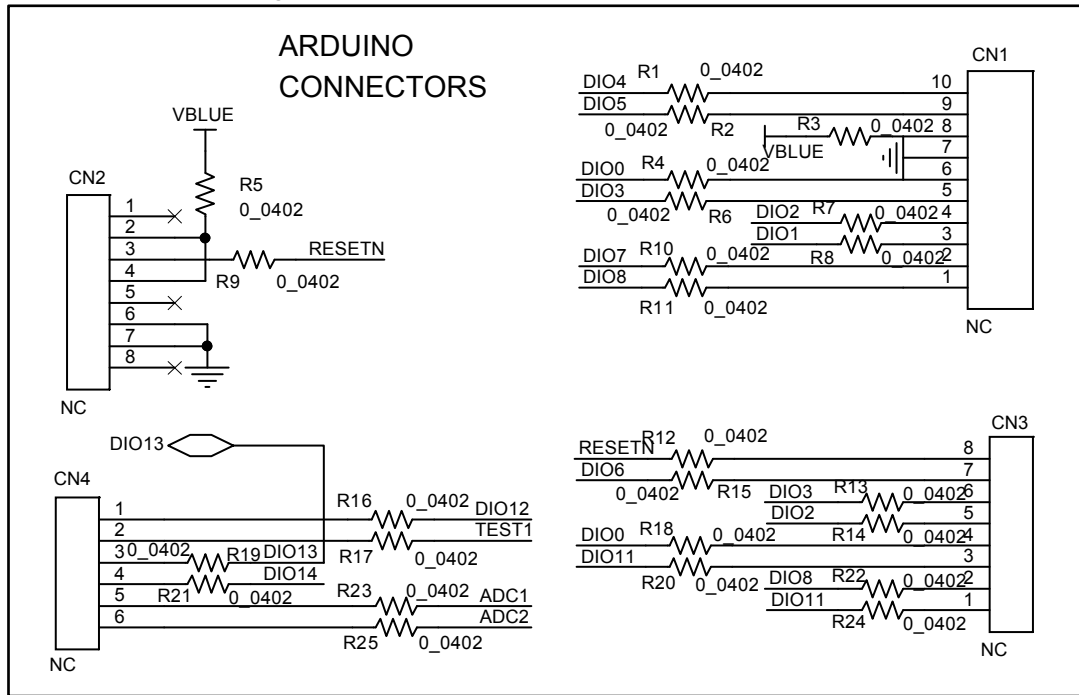

Figure 2: STEVAL-IDB007V1M - JTAG

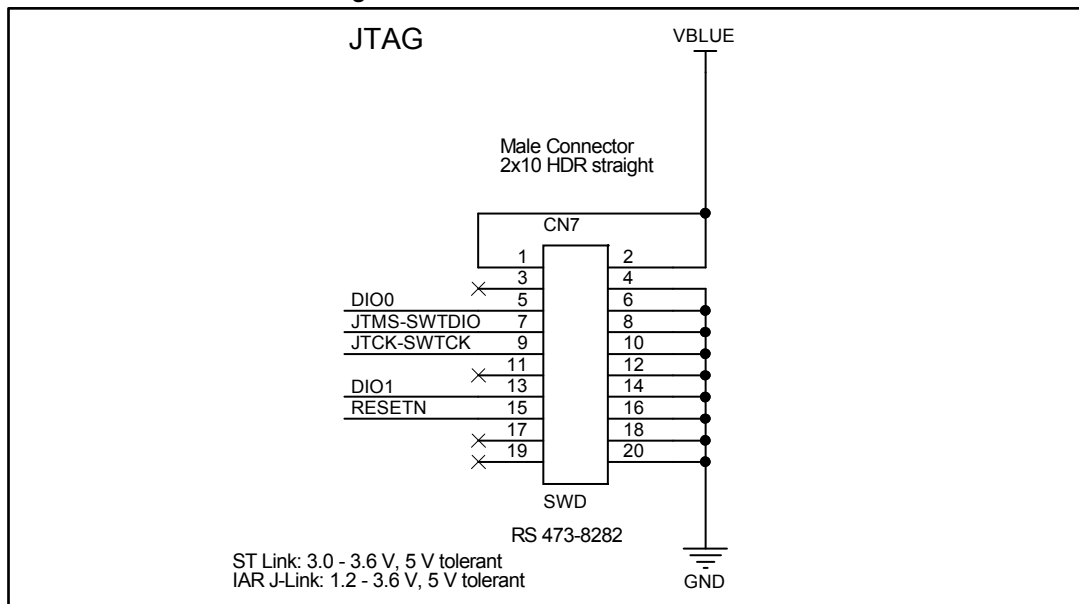

Figure 3: STEVAL-IDB007V1M - SPBTLE-1S module

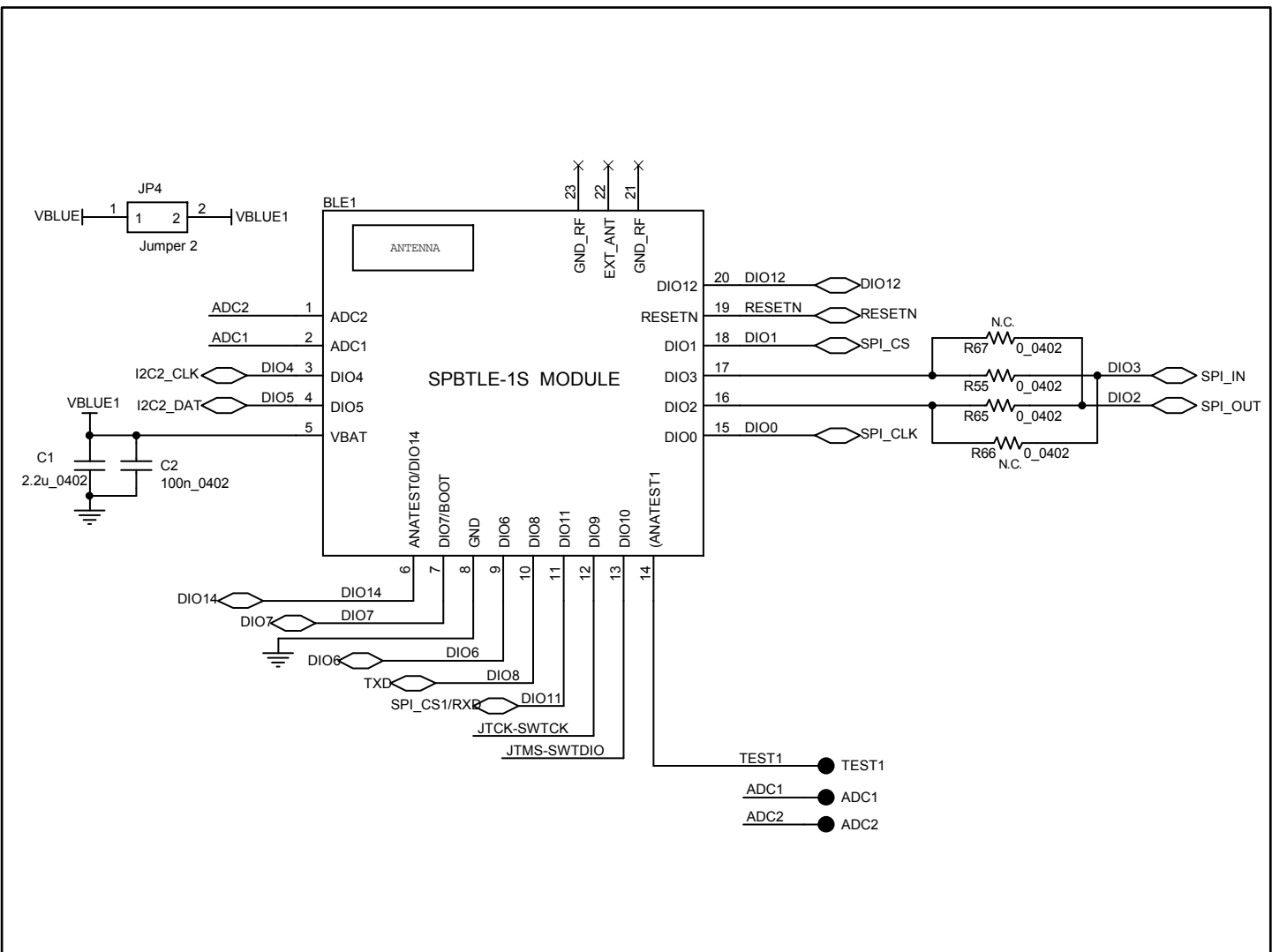

Figure 5: STEVAL-IDB007V1M - buttons and LEDs

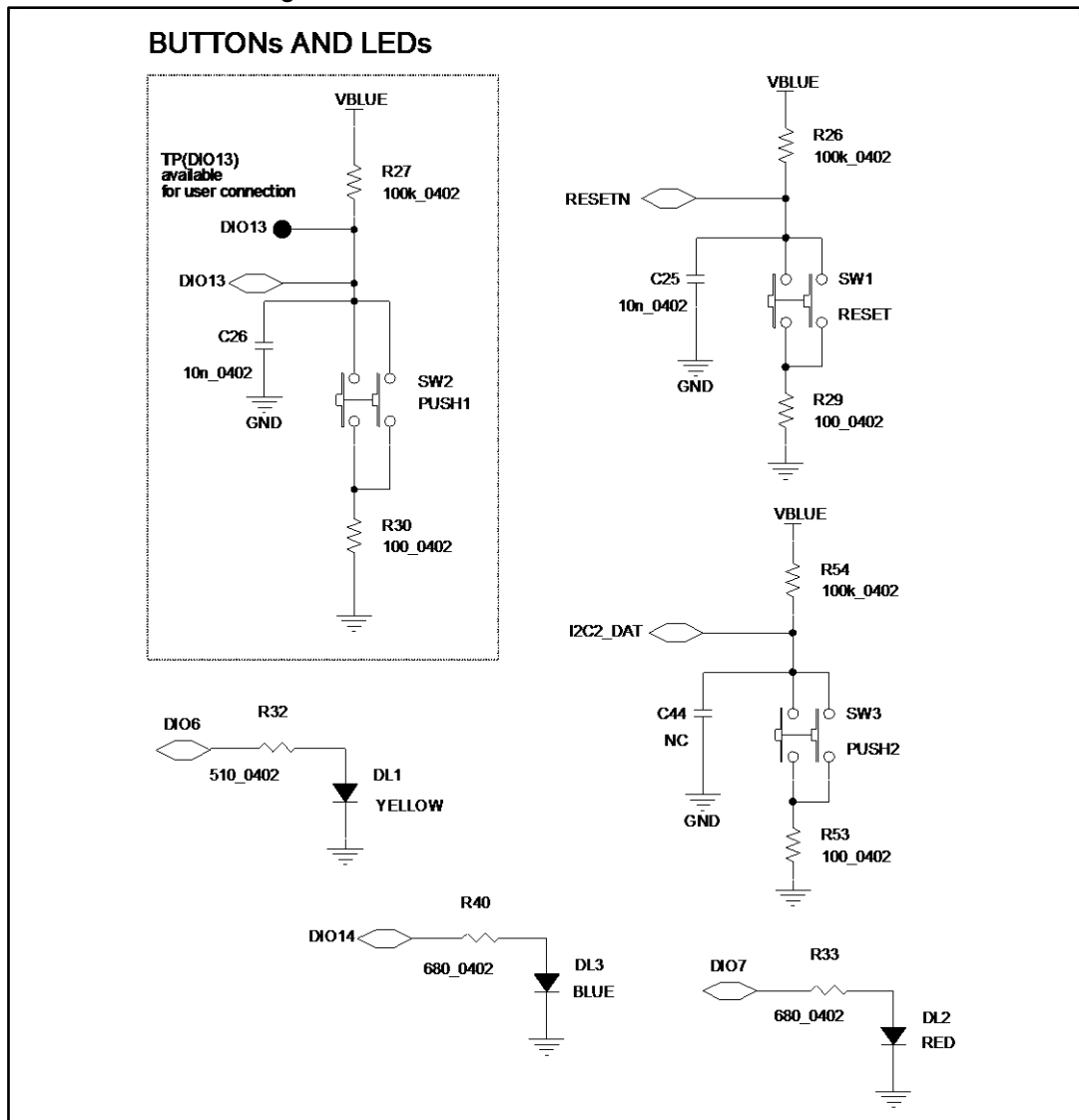

Figure 7: STEVAL-IDB007V1M - USB, level translator, JTAG for micro

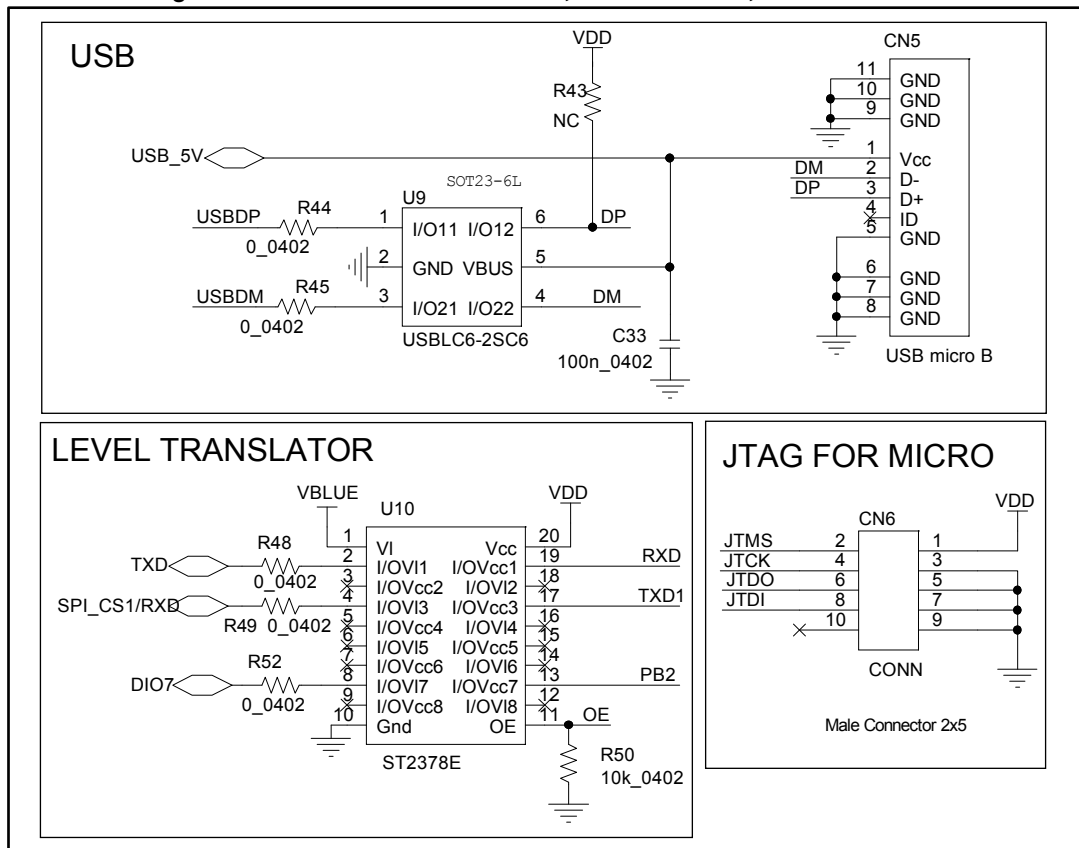
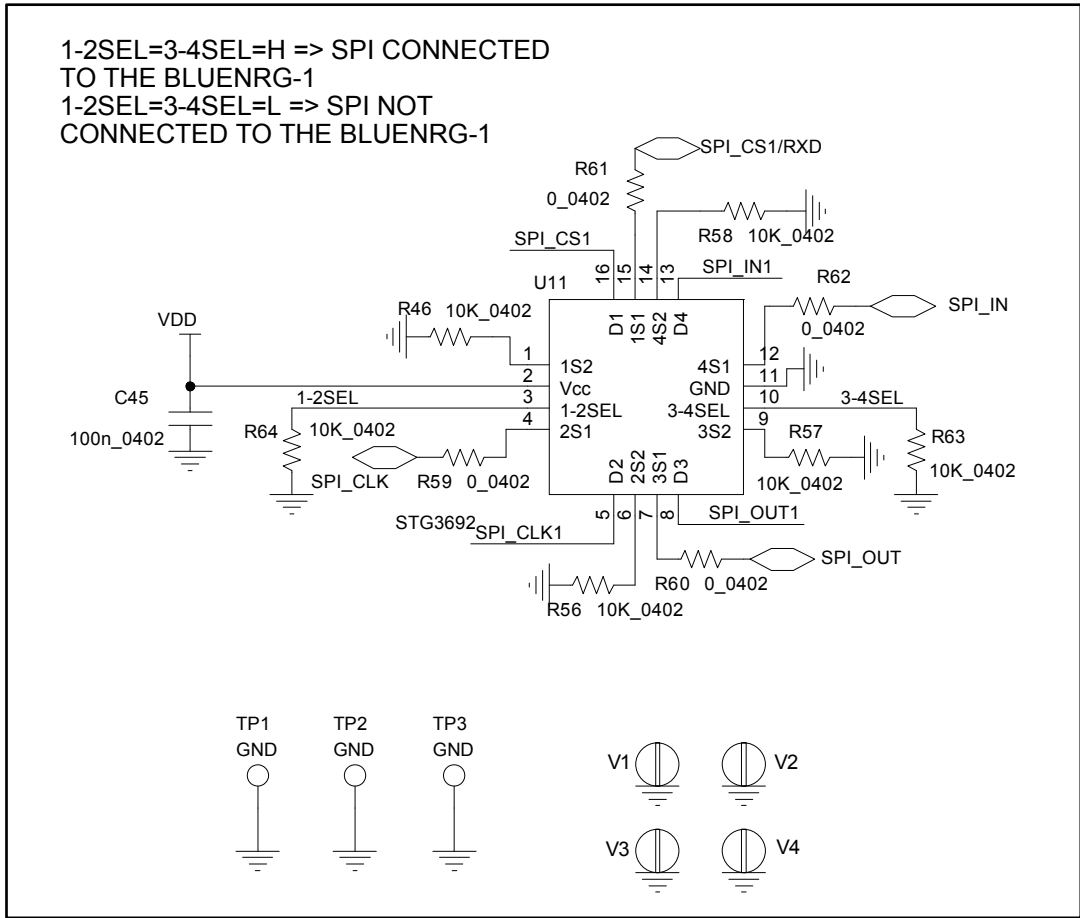

Figure 8: STEVAL-IDB007V1M - EEPROM



Revision history

Table 1: Document revision history

Date	Version	Changes
26-Jul-2017	1	Initial release.

IMPORTANT NOTICE – PLEASE READ CAREFULLY

STMicroelectronics NV and its subsidiaries ("ST") reserve the right to make changes, corrections, enhancements, modifications, and improvements to ST products and/or to this document at any time without notice. Purchasers should obtain the latest relevant information on ST products before placing orders. ST products are sold pursuant to ST's terms and conditions of sale in place at the time of order acknowledgement.

Purchasers are solely responsible for the choice, selection, and use of ST products and ST assumes no liability for application assistance or the design of Purchasers' products.

No license, express or implied, to any intellectual property right is granted by ST herein.

Resale of ST products with provisions different from the information set forth herein shall void any warranty granted by ST for such product.

ST and the ST logo are trademarks of ST. All other product or service names are the property of their respective owners.

Information in this document supersedes and replaces information previously supplied in any prior versions of this document.

© 2017 STMicroelectronics – All rights reserved