



Chipsmall Limited consists of a professional team with an average of over 10 year of expertise in the distribution of electronic components. Based in Hongkong, we have already established firm and mutual-benefit business relationships with customers from,Europe,America and south Asia,supplying obsolete and hard-to-find components to meet their specific needs.

With the principle of “Quality Parts,Customers Priority,Honest Operation,and Considerate Service”,our business mainly focus on the distribution of electronic components. Line cards we deal with include Microchip,ALPS,ROHM,Xilinx,Pulse,ON,Everlight and Freescale. Main products comprise IC,Modules,Potentiometer,IC Socket,Relay,Connector.Our parts cover such applications as commercial,industrial, and automotives areas.

We are looking forward to setting up business relationship with you and hope to provide you with the best service and solution. Let us make a better world for our industry!



## Contact us

Tel: +86-755-8981 8866 Fax: +86-755-8427 6832

Email & Skype: info@chipsmall.com Web: www.chipsmall.com

Address: A1208, Overseas Decoration Building, #122 Zhenhua RD., Futian, Shenzhen, China



## STEVAL-IDB007V2 evaluation platform based on the BlueNRG-1

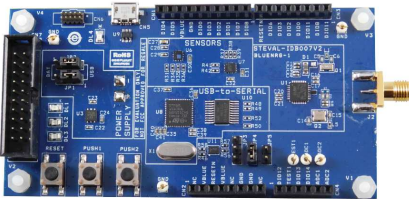

### Features

- Bluetooth® SMART board based on the BlueNRG-1 Bluetooth low energy system on chip
- Associated BlueNRG-1 development kit SW package including firmware and documentation
- Up to +8 dBm available output power (at antenna connector)
- Excellent receiver sensitivity (-88 dBm)
- Very low power consumption: 7.7 mA RX and 8.2 mA TX at +0 dBm
- Bluetooth® low energy compliant, supports master, slave and simultaneous master-and-slave roles
- New integrated balun BALF-NRG-02D3 which integrates a matching network and harmonics filter
- SMA connector for antenna or measuring equipment
- 3 user LEDs
- 2 user buttons
- 3D digital accelerometer and 3D digital gyroscope
- MEMS pressure sensor with embedded temperature sensor
- Battery holder
- JTAG debug connector
- USB to serial bridge for providing I/O channel with the BlueNRG-1 device
- Jumper for measuring current for BlueNRG-1 only
- RoHS compliant

### Summary table

STEVAL-IDB007V2 evaluation platform based on the BlueNRG-1	STEVAL-IDB007V2
Bluetooth low energy wireless system-on-chip	BlueNRG-1

### Description

The **STEVAL-IDB007V2** evaluation platform is based on the **BlueNRG-1**, low power Bluetooth® smart system on chip, compliant with the Bluetooth® specification and supporting master, slave and simultaneous master-and-slave roles.

The STEVAL-IDB007V2 also provides a set of hardware resources for implementing a wide range of application scenarios: sensor data (accelerometer, pressure and temperature sensor), remote control (buttons and LEDs) and debug message management through USB virtual COM.

Three power options are available (USB only, battery only, and external power supply plus USB) for high application development and testing flexibility.

# 1 Schematic diagrams for STEVAL-IDB007V2

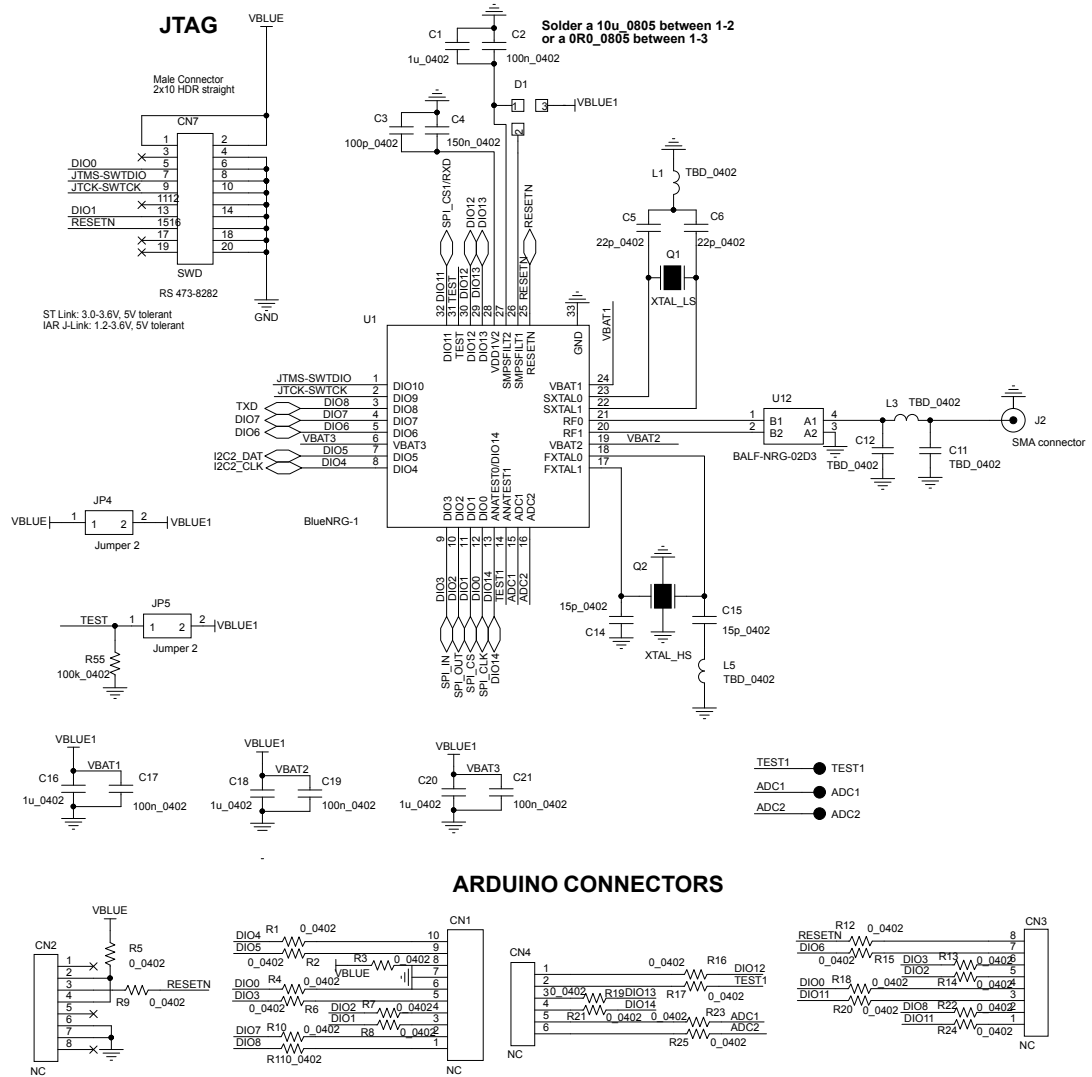
**Figure 1. STEVAL-IDB007V2 - scheme 1**



## Revision history

**Table 1. Document revision history**

Date	Version	Changes
15-Jan-2018	1	Initial release.
23-Jan-2018	2	Updated: <a href="#">Section 1 Schematic diagrams for STEVAL-IDB007V2</a>

**IMPORTANT NOTICE – PLEASE READ CAREFULLY**

STMicroelectronics NV and its subsidiaries (“ST”) reserve the right to make changes, corrections, enhancements, modifications, and improvements to ST products and/or to this document at any time without notice. Purchasers should obtain the latest relevant information on ST products before placing orders. ST products are sold pursuant to ST’s terms and conditions of sale in place at the time of order acknowledgement.

Purchasers are solely responsible for the choice, selection, and use of ST products and ST assumes no liability for application assistance or the design of Purchasers’ products.

No license, express or implied, to any intellectual property right is granted by ST herein.

Resale of ST products with provisions different from the information set forth herein shall void any warranty granted by ST for such product.

ST and the ST logo are trademarks of ST. All other product or service names are the property of their respective owners.

Information in this document supersedes and replaces information previously supplied in any prior versions of this document.

© 2018 STMicroelectronics – All rights reserved