



Chipsmall Limited consists of a professional team with an average of over 10 year of expertise in the distribution of electronic components. Based in Hongkong, we have already established firm and mutual-benefit business relationships with customers from,Europe,America and south Asia,supplying obsolete and hard-to-find components to meet their specific needs.

With the principle of “Quality Parts,Customers Priority,Honest Operation,and Considerate Service”,our business mainly focus on the distribution of electronic components. Line cards we deal with include Microchip,ALPS,ROHM,Xilinx,Pulse,ON,Everlight and Freescale. Main products comprise IC,Modules,Potentiometer,IC Socket,Relay,Connector.Our parts cover such applications as commercial,industrial, and automotives areas.

We are looking forward to setting up business relationship with you and hope to provide you with the best service and solution. Let us make a better world for our industry!



Contact us

Tel: +86-755-8981 8866 Fax: +86-755-8427 6832

Email & Skype: info@chipsmall.com Web: www.chipsmall.com

Address: A1208, Overseas Decoration Building, #122 Zhenhua RD., Futian, Shenzhen, China



Evaluation platform based on the BlueNRG-2



Features

- Bluetooth® SMART board based on the BlueNRG-2 Bluetooth low energy system on chip
- Associated BlueNRG-2 development kit SW package including firmware and documentation
- Up to +8 dBm available output power (at antenna connector)
- Excellent receiver sensitivity (-88 dBm)
- Very low power consumption: 7.7 mA RX and 8.2 mA TX at +0 dBm
- Bluetooth® SMART v5.0 compliant, supports master, slave, simultaneous master-and-slave roles and Bluetooth low energy extended data length feature
- New integrated balun BALF-NRG-02D3 which integrates a matching network and harmonics filter
- SMA connector for antenna or measuring equipment
- 3 user LEDs
- 2 user buttons
- 3D digital accelerometer and 3D digital gyroscope
- MEMS pressure sensor with embedded temperature sensor
- RoHS compliant

Description

The [STEVAL-IDB008V2](#) evaluation platform is based on the [BlueNRG-2](#), low power Bluetooth® smart system on chip with 256 KB Flash, 24 KB RAM, compliant with the Bluetooth® SMART v5.0 specification, supporting master, slave and simultaneous master-and-slave roles and the Bluetooth low energy extended data length feature.

The STEVAL-IDB008V2 also provides a set of hardware resources for implementing a wide range of application scenarios: sensor data (accelerometer, pressure and temperature sensor), remote control (buttons and LEDs) and debug message management through USB virtual COM. Three power options are available (USB only, battery only, and external power supply plus USB) for high application development and testing flexibility.

Summary table	
STEVAL-IDB008V2 evaluation platform based on the BlueNRG-2	STEVAL-IDB008V2
Bluetooth low energy wireless system-on-chip	BlueNRG-2

1 Schematic diagrams for STEVAL-IDB008V2

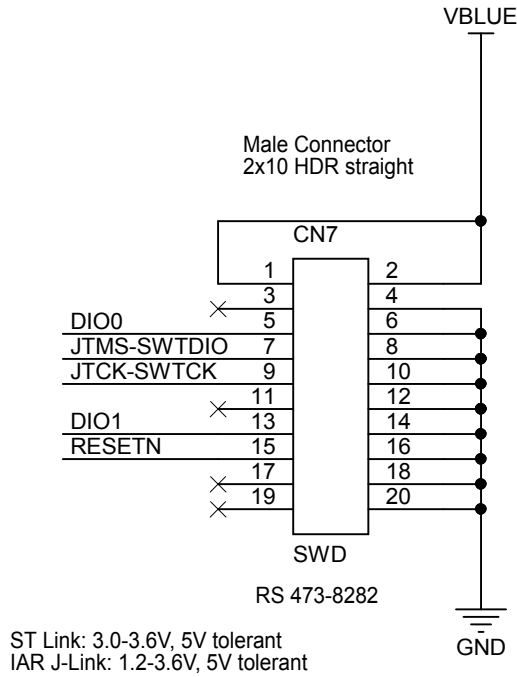
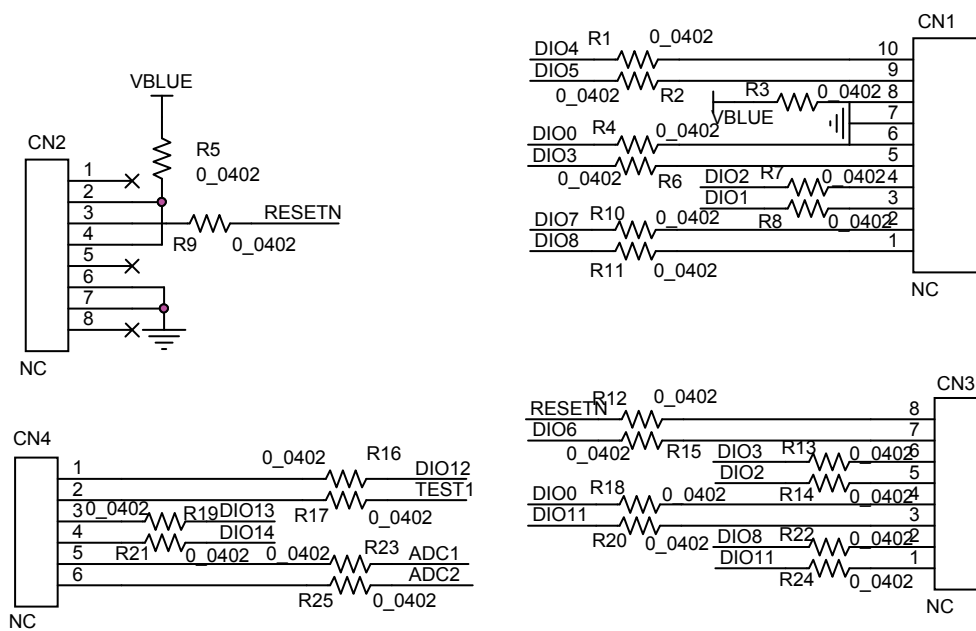
Figure 1. STEVAL-IDB008V2 - JTAG

Figure 2. STEVAL-IDB008V2 - Arduino connection


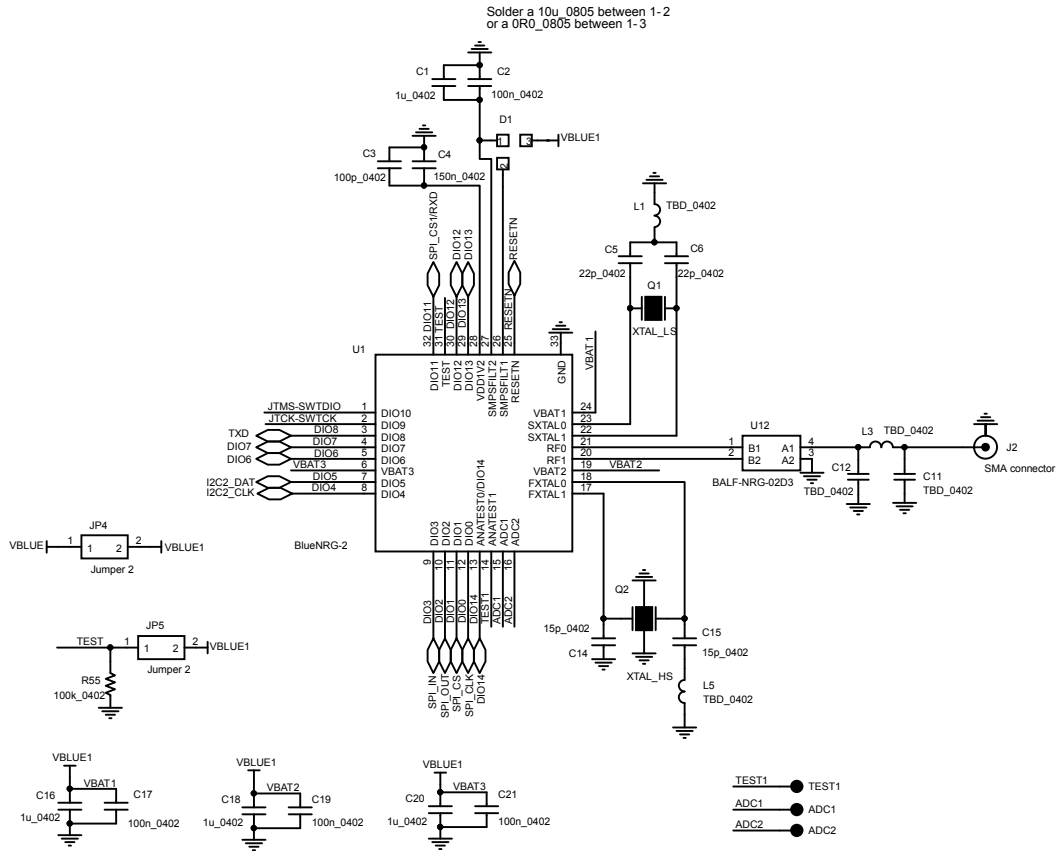
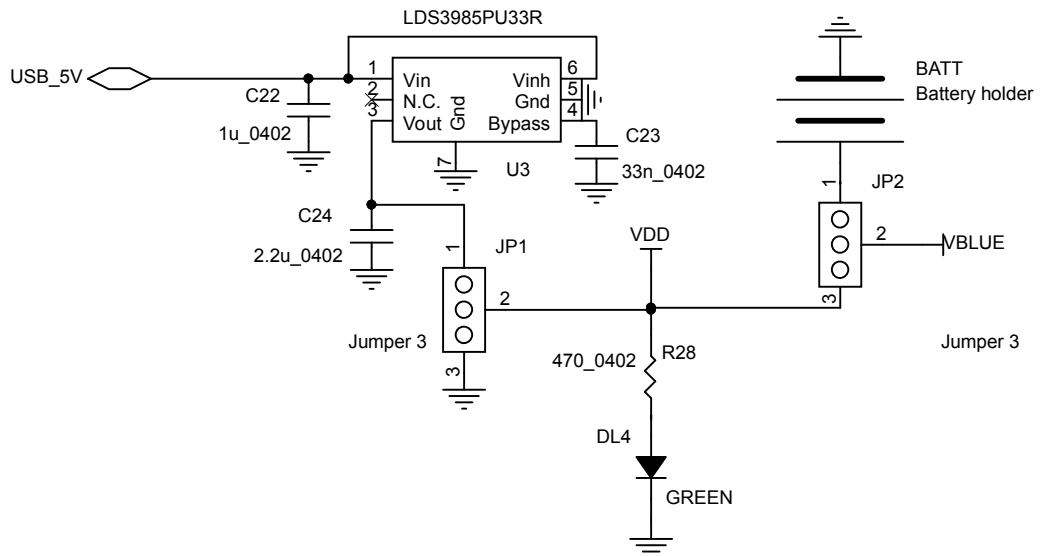
Figure 3. STEVAL-IDB008V2 circuit schematic

Figure 4. STEVAL-IDB008V2 - power managements


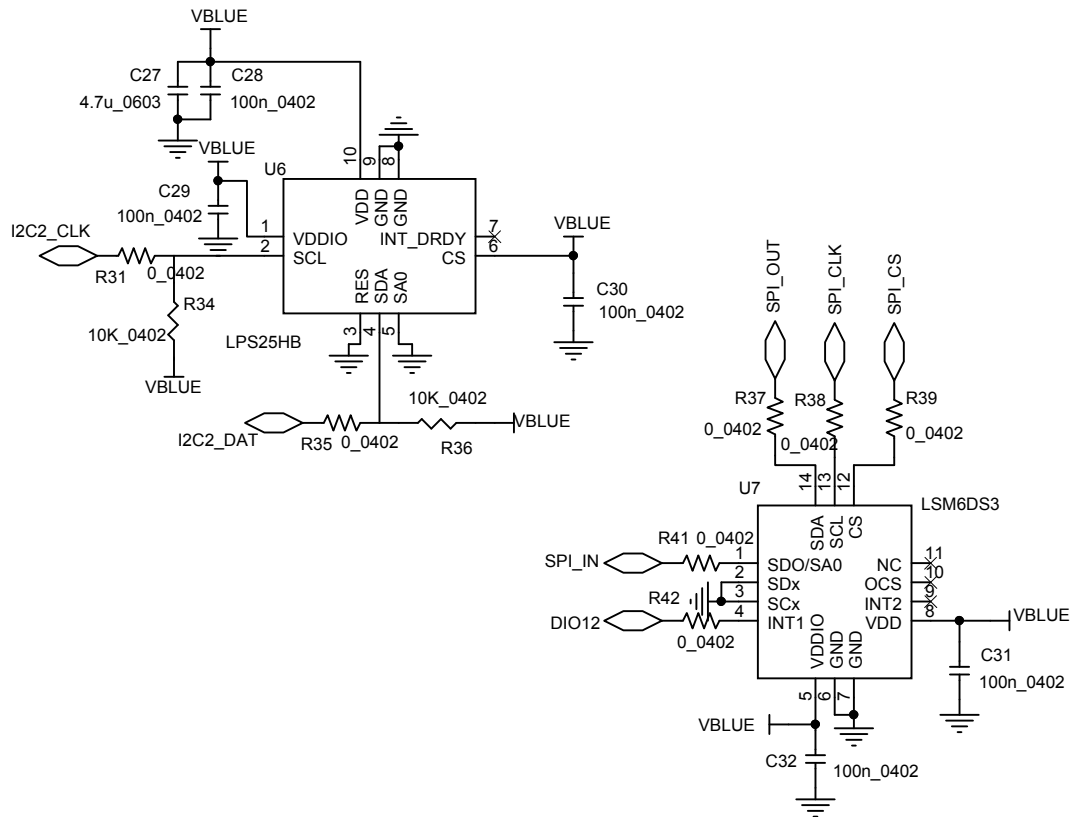
Figure 5. STEVAL-IDB008V2 - SENSORS


Figure 6. STEVAL-IDB008V2 - buttons and leds

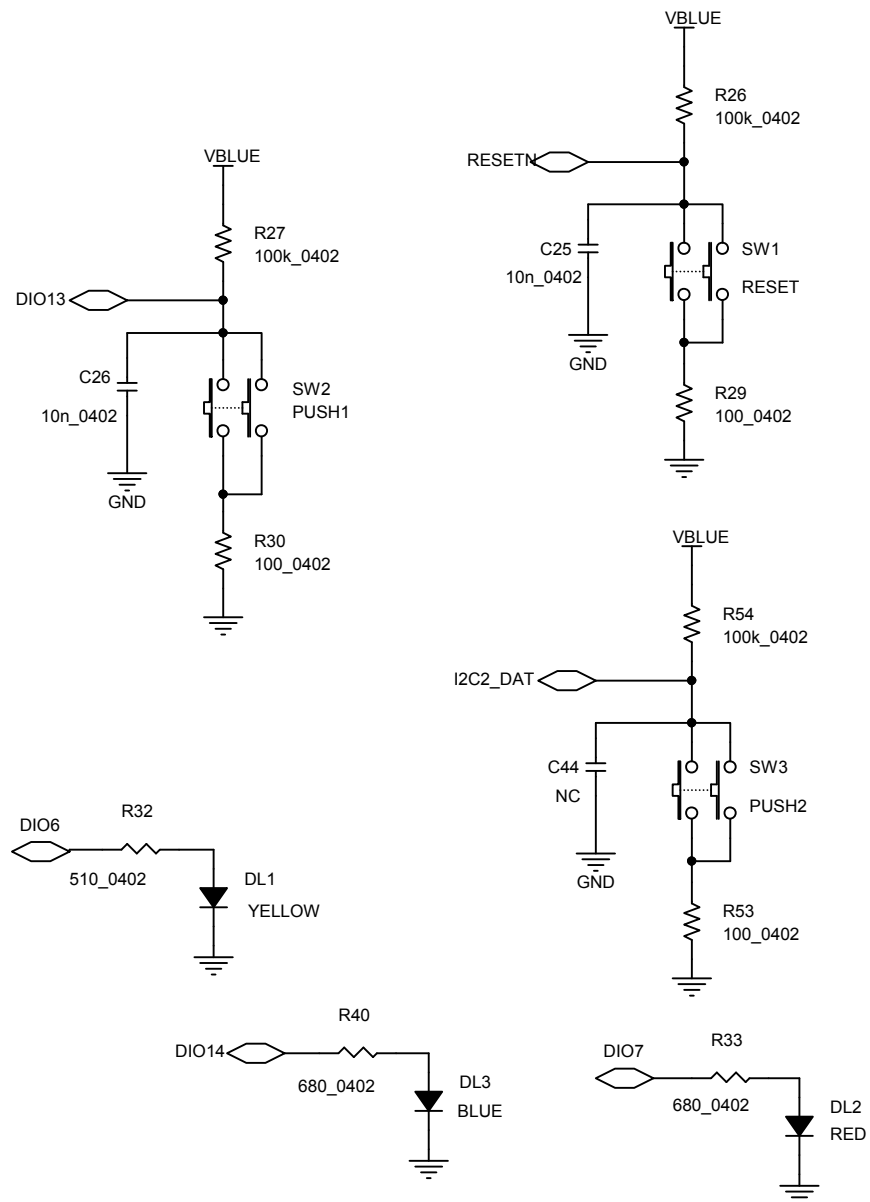


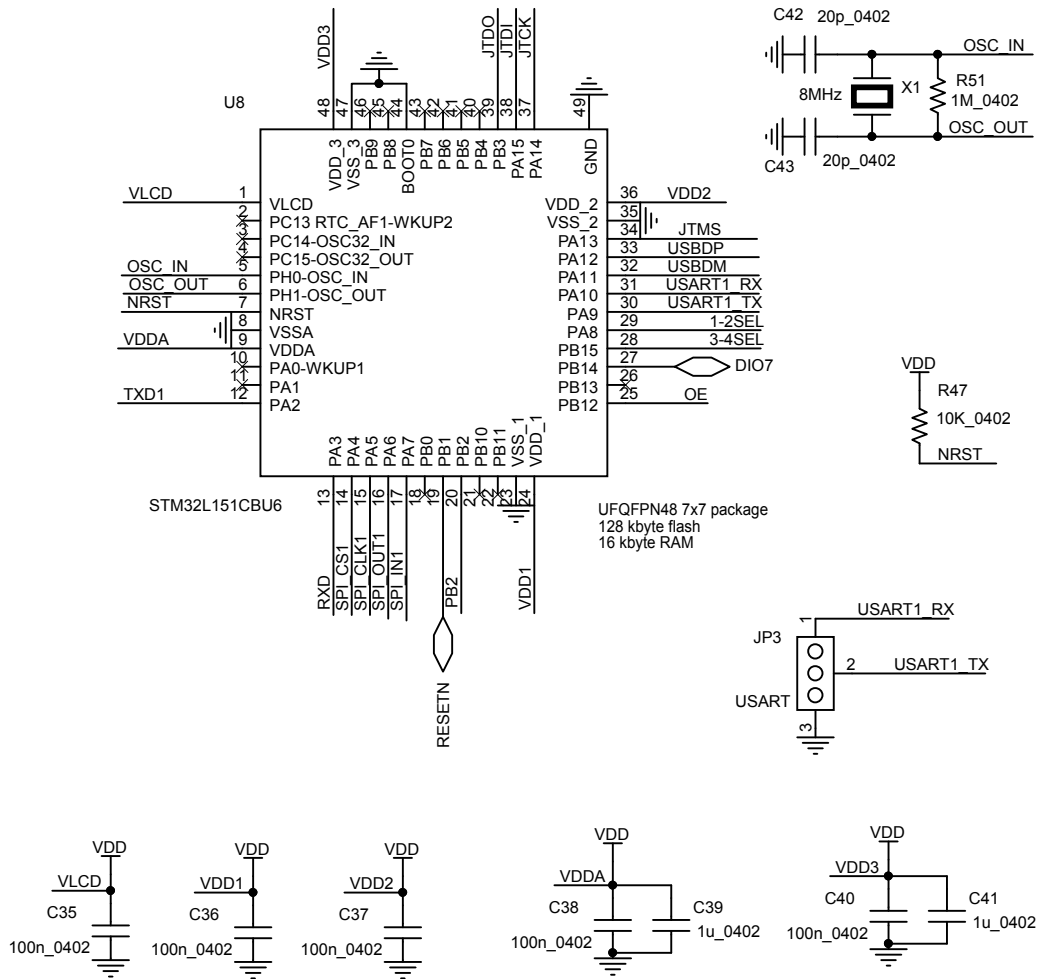
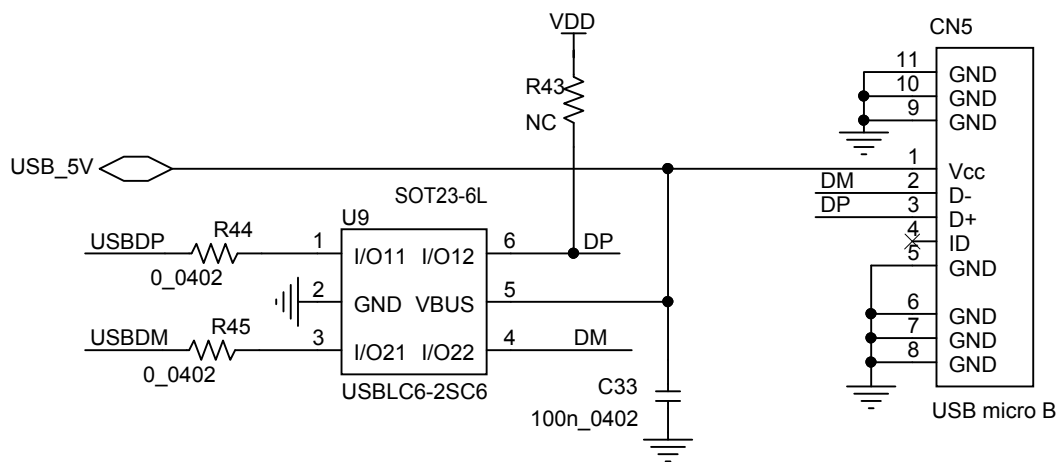
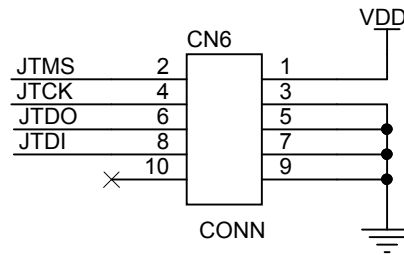
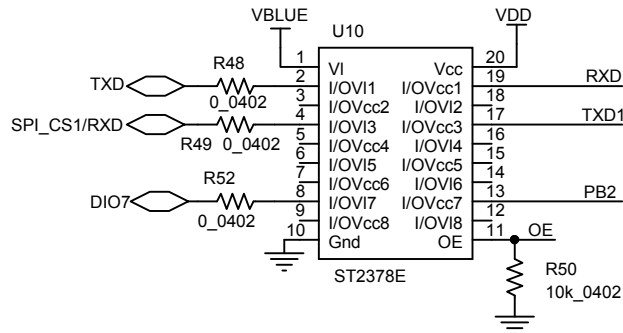
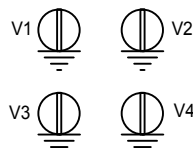
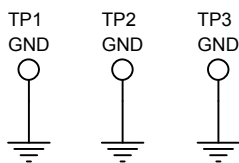
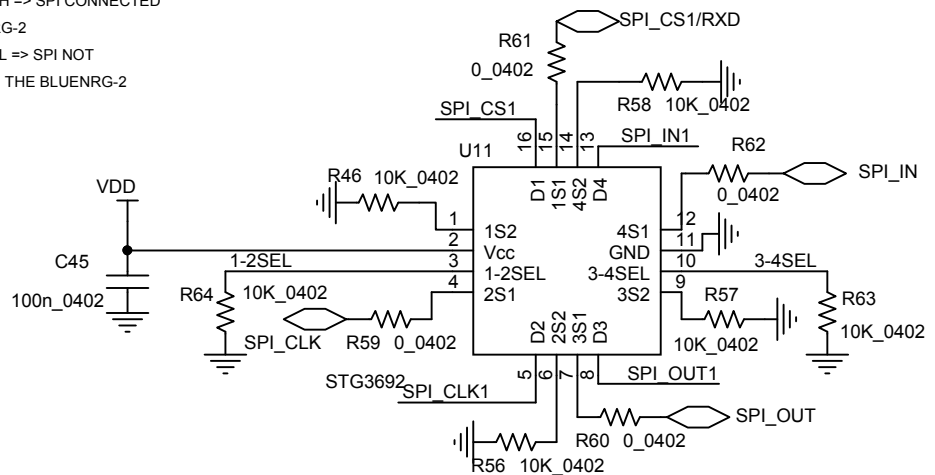
Figure 7. STEVAL-IDB008V2 - micro

Figure 8. STEVAL-IDB008V2 - USB


Figure 9. STEVAL-IDB008V2 - JTAG for micro


Male Connector 2x5

Figure 10. STEVAL-IDB008V2 - level translator

Figure 11. STEVAL-IDB008V2 - Switch

1-2SEL=3-4SEL=H => SPI CONNECTED
TO THE BLUENRG-2
1-2SEL=3-4SEL=L => SPI NOT
CONNECTED TO THE BLUENRG-2



Revision history

Table 1. Document revision history

Date	Version	Changes
11-Jan-2018	1	Initial release.
23-Jan-2018	2	Updated: Section 1 Schematic diagrams for STEVAL-IDB008V2 .
13-Feb-2018	3	Fixed figure 7

IMPORTANT NOTICE – PLEASE READ CAREFULLY

STMicroelectronics NV and its subsidiaries (“ST”) reserve the right to make changes, corrections, enhancements, modifications, and improvements to ST products and/or to this document at any time without notice. Purchasers should obtain the latest relevant information on ST products before placing orders. ST products are sold pursuant to ST’s terms and conditions of sale in place at the time of order acknowledgement.

Purchasers are solely responsible for the choice, selection, and use of ST products and ST assumes no liability for application assistance or the design of Purchasers’ products.

No license, express or implied, to any intellectual property right is granted by ST herein.

Resale of ST products with provisions different from the information set forth herein shall void any warranty granted by ST for such product.

ST and the ST logo are trademarks of ST. All other product or service names are the property of their respective owners.

Information in this document supersedes and replaces information previously supplied in any prior versions of this document.

© 2018 STMicroelectronics – All rights reserved