



Chipsmall Limited consists of a professional team with an average of over 10 year of expertise in the distribution of electronic components. Based in Hongkong, we have already established firm and mutual-benefit business relationships with customers from,Europe,America and south Asia,supplying obsolete and hard-to-find components to meet their specific needs.

With the principle of “Quality Parts,Customers Priority,Honest Operation,and Considerate Service”,our business mainly focus on the distribution of electronic components. Line cards we deal with include Microchip,ALPS,ROHM,Xilinx,Pulse,ON,Everlight and Freescale. Main products comprise IC,Modules,Potentiometer,IC Socket,Relay,Connector.Our parts cover such applications as commercial,industrial, and automotives areas.

We are looking forward to setting up business relationship with you and hope to provide you with the best service and solution. Let us make a better world for our industry!



Contact us

Tel: +86-755-8981 8866 Fax: +86-755-8427 6832

Email & Skype: info@chipsmall.com Web: www.chipsmall.com

Address: A1208, Overseas Decoration Building, #122 Zhenhua RD., Futian, Shenzhen, China



Multi-sensor RF platform 6LoWPAN & NFC interface board

Data brief

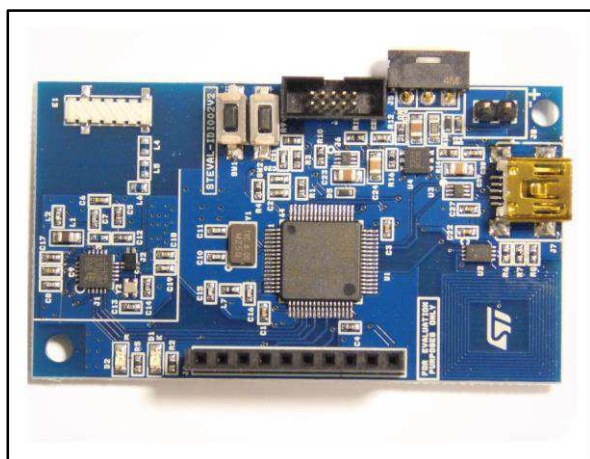
**Description**

The STEVAL-IDI002V2 is an evaluation platform for a 6LoWPAN multi-sensor RF network based on the SPIRIT1 Sub-GHz RF transceiver and the STM32L152RBT6 low power Cortex M3 microcontroller. The STM32L152RBT6 runs the open source 6LoWPAN Contiki stack. In addition to the 6LoWPAN stack, an application is provided which communicates with the various sensors on the STEVAL-IDI003V2 daughterboard through a 10-pin connector. Alternatively, this connector can be used to control/interface with any sensor or actuator. This 6LoWPAN multi-sensor RF board communicates with the STEVAL-IDI004V2 IoT wireless bridge evaluation board.

Features

- SPIRIT1-based 868 MHz RF platform
- Low power STM32L series microcontroller
- Contains the M24LR64E dual EEPROM
- Can be powered by USB or Li-Ion battery
- Runs the 6LoWPAN Contiki stack
- SPIRIT1:
 - Supports from 150 MHz to 956 MHz
 - 9 mA receiving & 21 mA transmitting at +11 dbm
 - Built-in AES 128-bit encryption
 - sensitivity up to -118 dbm
- To be used with multi-sensor board STEVAL-IDI003V2
- Can be used to evaluate/develop applications for IoT
- Android App available to connect to STEVAL-IDI004V2
- RoHS compliant

1 Schematic diagrams

Figure 1: STEVAL-IDI002V2 circuit schematic (1 of 7)

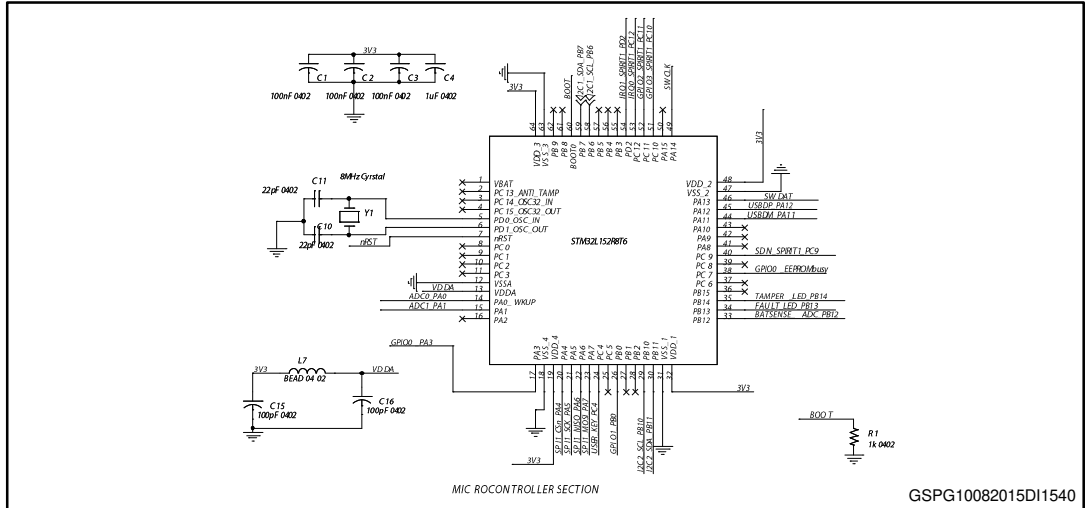

Figure 2: STEVAL-IDI002V2 circuit schematic (2 of 7)

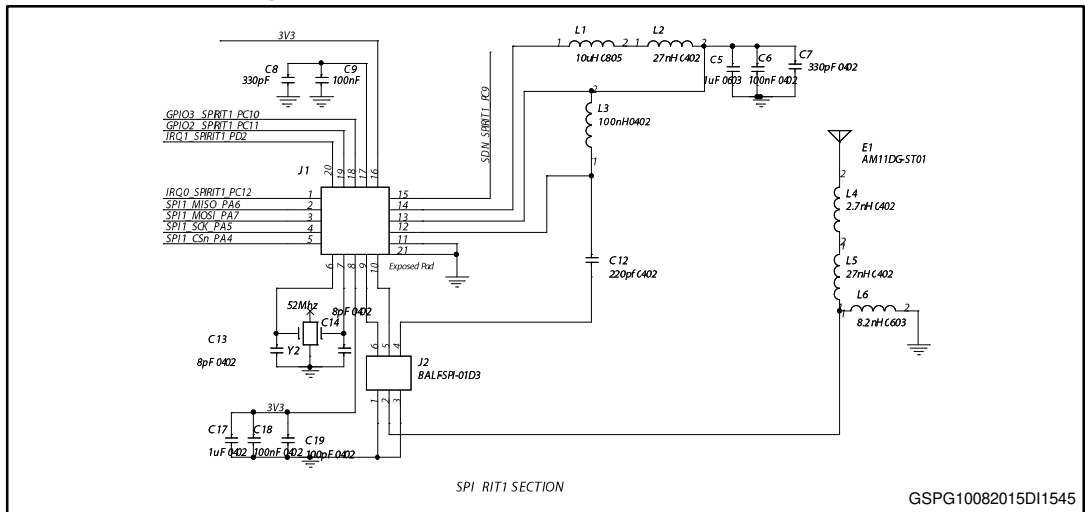
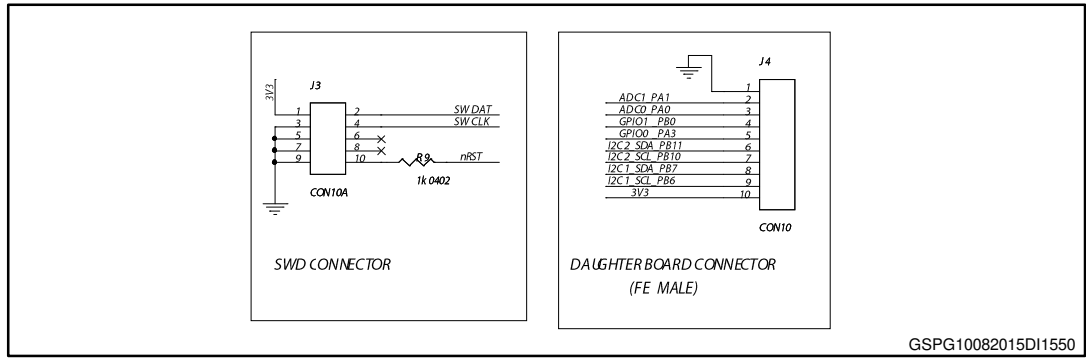
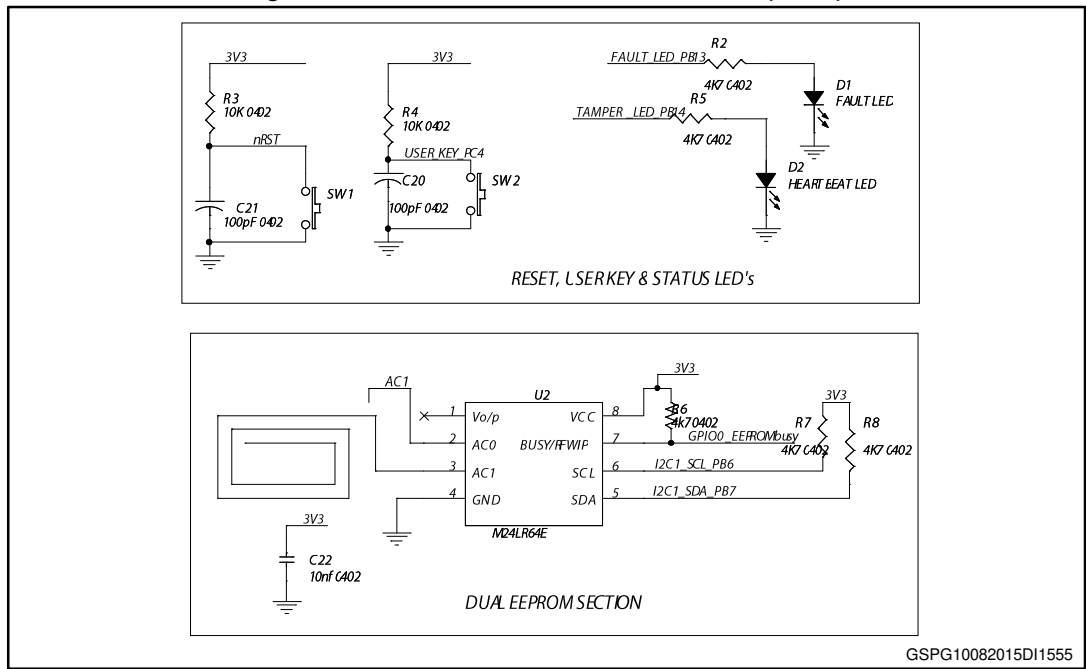

Figure 3: STEVAL-IDI002V2 circuit schematic (3 of 7)



GSPG10082015DI1550

Figure 4: STEVAL-IDI002V2 circuit schematic (4 of 7)



GSPG10082015DI1555

Figure 5: STEVAL-IDI002V2 circuit schematic (5 of 7)

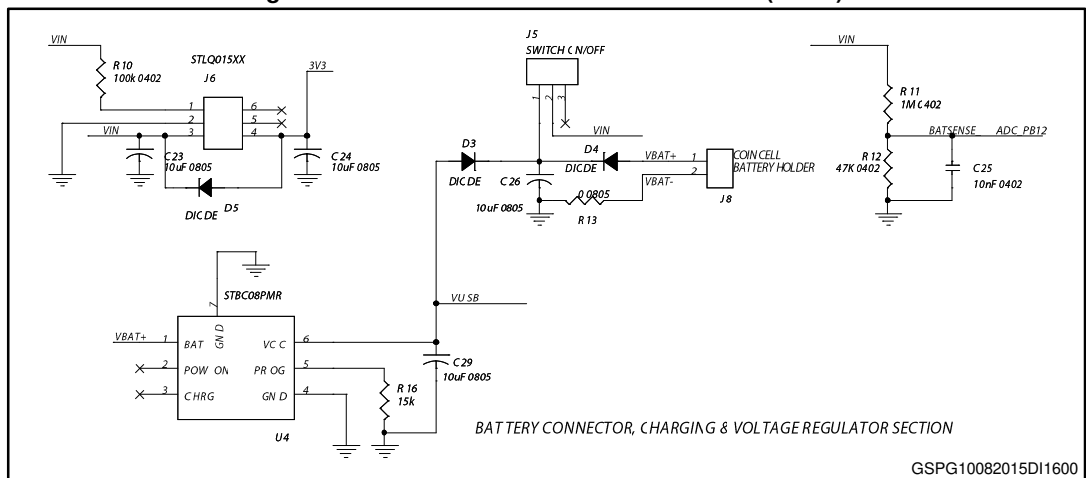

GSPG10082015DI1600

Figure 6: STEVAL-IDI002V2 circuit schematic (6 of 7)

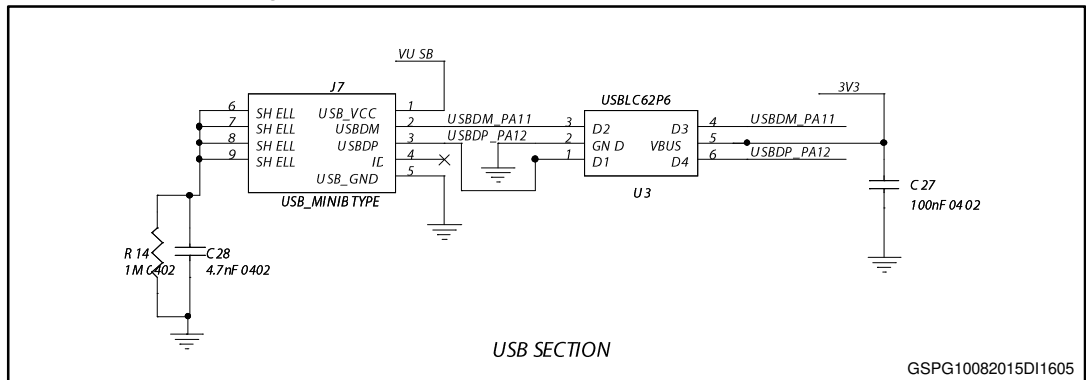
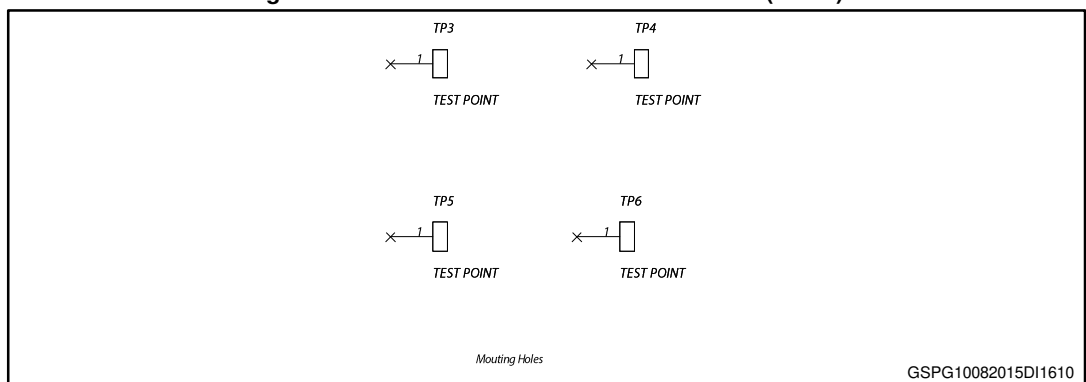

Figure 7: STEVAL-IDI002V2 circuit schematic (7 of 7)



2 Revision history

Table 1: Document revision history

Date	Version	Changes
06-Oct-2015	1	Initial release.

IMPORTANT NOTICE – PLEASE READ CAREFULLY

STMicroelectronics NV and its subsidiaries ("ST") reserve the right to make changes, corrections, enhancements, modifications, and improvements to ST products and/or to this document at any time without notice. Purchasers should obtain the latest relevant information on ST products before placing orders. ST products are sold pursuant to ST's terms and conditions of sale in place at the time of order acknowledgement.

Purchasers are solely responsible for the choice, selection, and use of ST products and ST assumes no liability for application assistance or the design of Purchasers' products.

No license, express or implied, to any intellectual property right is granted by ST herein.

Resale of ST products with provisions different from the information set forth herein shall void any warranty granted by ST for such product.

ST and the ST logo are trademarks of ST. All other product or service names are the property of their respective owners.

Information in this document supersedes and replaces information previously supplied in any prior versions of this document.

© 2015 STMicroelectronics – All rights reserved