



Chipsmall Limited consists of a professional team with an average of over 10 year of expertise in the distribution of electronic components. Based in Hongkong, we have already established firm and mutual-benefit business relationships with customers from,Europe,America and south Asia,supplying obsolete and hard-to-find components to meet their specific needs.

With the principle of “Quality Parts,Customers Priority,Honest Operation,and Considerate Service”,our business mainly focus on the distribution of electronic components. Line cards we deal with include Microchip,ALPS,ROHM,Xilinx,Pulse,ON,Everlight and Freescale. Main products comprise IC,Modules,Potentiometer,IC Socket,Relay,Connector.Our parts cover such applications as commercial,industrial, and automotives areas.

We are looking forward to setting up business relationship with you and hope to provide you with the best service and solution. Let us make a better world for our industry!



Contact us

Tel: +86-755-8981 8866 Fax: +86-755-8427 6832

Email & Skype: info@chipsmall.com Web: www.chipsmall.com

Address: A1208, Overseas Decoration Building, #122 Zhenhua RD., Futian, Shenzhen, China



Extension board with ACS switches for STM8S Discovery Kit

Data brief

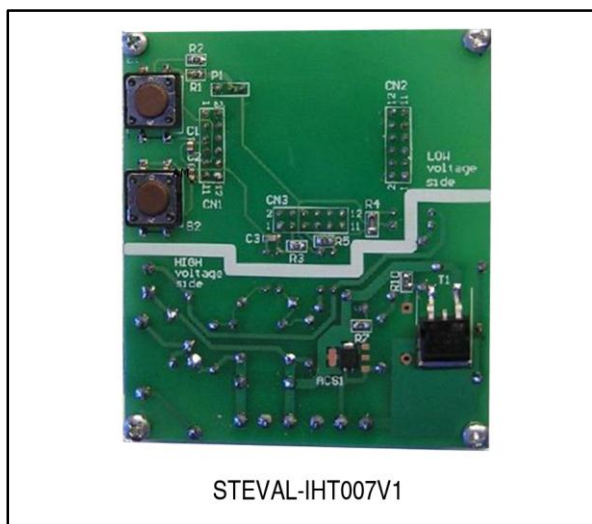

Description

The STEVAL-IHT007V1 is an extension board for the STM8S Discovery Kit that provides a simple tool for control of AC loads with ACS switches in markets accepting the STM8S Discovery Kit. The target application is small AC loads of up to 500 W, used in home appliances and home and building automation.

Features

- Direct drive of 110/220 VAC loads
- Opto-transistors to isolate the high voltage side
- Zero voltage switching to synchronize Triac / AC switch pulses with AC mains
- RoHS compliant

1 Schematic diagram

Figure 1: STEVAL-IHT007V1 circuit schematic

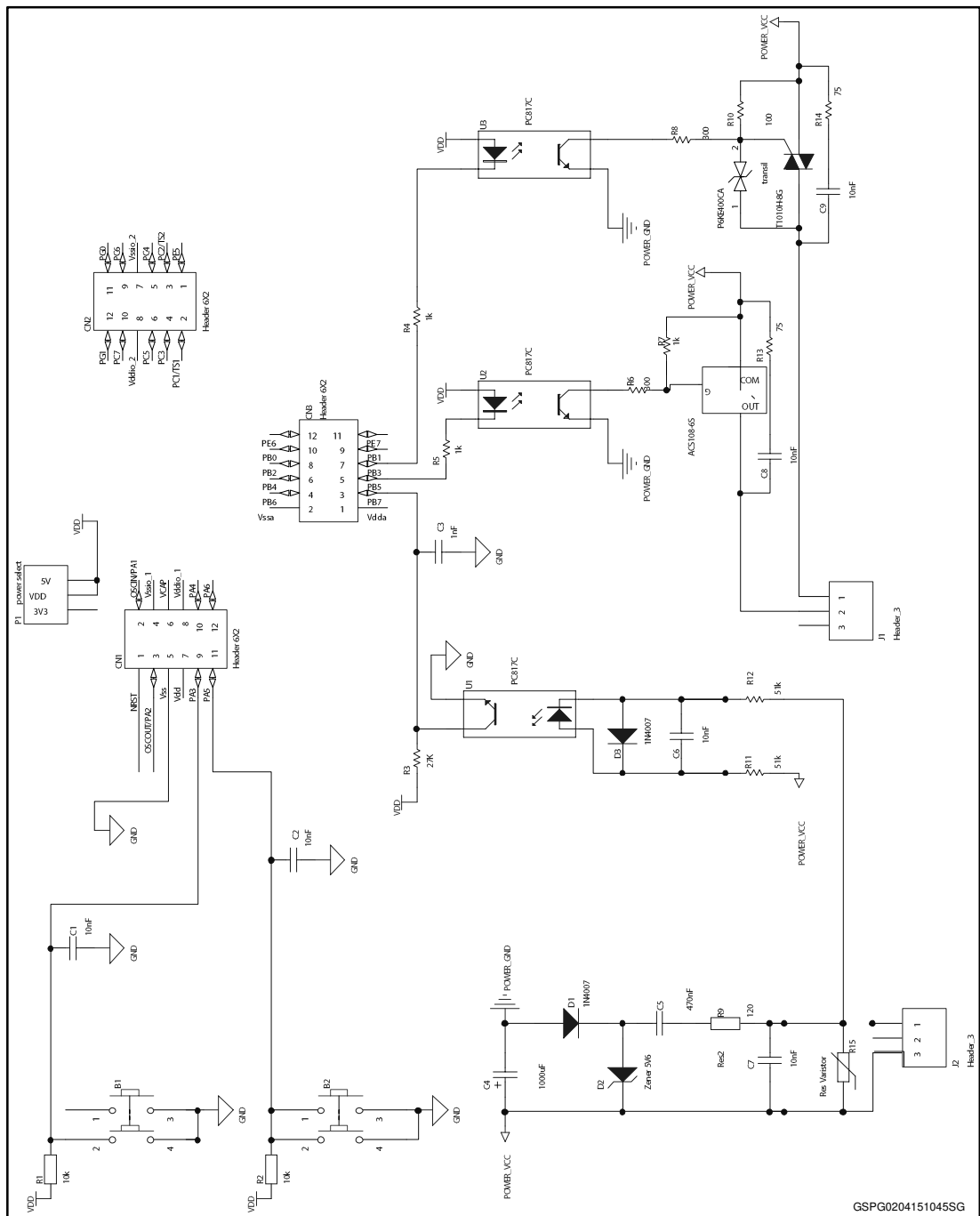

2 Revision history

Table 1: Document revision history

Date	Rev	Changes
16-Nov-2011	1	First release.
18-Nov-2011	2	Modified board name in the coverpage photo
16-Dec-2011	3	Modified Features in cover page
02-Mar-2015	4	Modified Features in cover page

IMPORTANT NOTICE – PLEASE READ CAREFULLY

STMicroelectronics NV and its subsidiaries ("ST") reserve the right to make changes, corrections, enhancements, modifications, and improvements to ST products and/or to this document at any time without notice. Purchasers should obtain the latest relevant information on ST products before placing orders. ST products are sold pursuant to ST's terms and conditions of sale in place at the time of order acknowledgement.

Purchasers are solely responsible for the choice, selection, and use of ST products and ST assumes no liability for application assistance or the design of Purchasers' products.

No license, express or implied, to any intellectual property right is granted by ST herein.

Resale of ST products with provisions different from the information set forth herein shall void any warranty granted by ST for such product.

ST and the ST logo are trademarks of ST. All other product or service names are the property of their respective owners.

Information in this document supersedes and replaces information previously supplied in any prior versions of this document.

© 2015 STMicroelectronics – All rights reserved