



Chipsmall Limited consists of a professional team with an average of over 10 year of expertise in the distribution of electronic components. Based in Hongkong, we have already established firm and mutual-benefit business relationships with customers from,Europe,America and south Asia,supplying obsolete and hard-to-find components to meet their specific needs.

With the principle of “Quality Parts,Customers Priority,Honest Operation,and Considerate Service”,our business mainly focus on the distribution of electronic components. Line cards we deal with include Microchip,ALPS,ROHM,Xilinx,Pulse,ON,Everlight and Freescale. Main products comprise IC,Modules,Potentiometer,IC Socket,Relay,Connector.Our parts cover such applications as commercial,industrial, and automotives areas.

We are looking forward to setting up business relationship with you and hope to provide you with the best service and solution. Let us make a better world for our industry!



Contact us

Tel: +86-755-8981 8866 Fax: +86-755-8427 6832

Email & Skype: info@chipsmall.com Web: www.chipsmall.com

Address: A1208, Overseas Decoration Building, #122 Zhenhua RD., Futian, Shenzhen, China





Multi-channel LED driver with integrated boost controller for medium, large LCD panel backlight based on LED7708 and STM32F103C6T6A

Data brief

Features

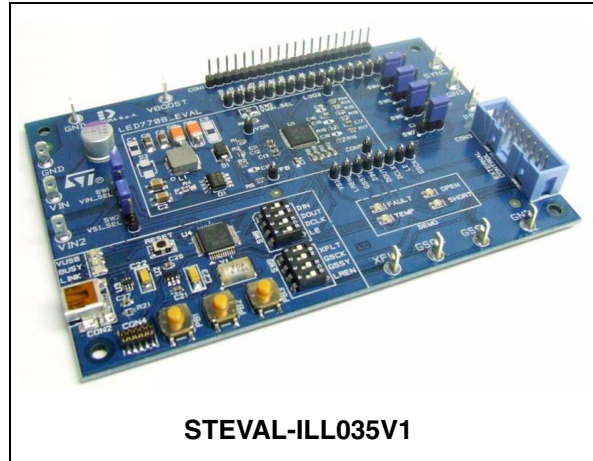
- Wide DC input voltage: 10 V to 28 V
- Integrated boost converter with adaptive output voltage for minimum power dissipation
- Up to 92% boost converter efficiency
- 16 channels with up to 85 mA/ch current capability and independent PWM brightness control
- Up to 15 white LEDs per channel
- On-board STM32 microcontroller for total device control through 4-wire serial interface
- Embedded open-channel and LED short-circuit faults management
- USB connection for device control through dedicated PC-GUI
- Expansion connector to support slave devices (daughterboard)
- RoHS compliant

Description

The purpose of the STEVAL-ILL035V1 demonstration board is to provide an application example of a compact LED backlight driver using the LED7708 device.

The board is equipped with a 16-channel LED driver with integrated boost controller (the LED7708), power section components, and an STM32 microcontroller to easily control all the features via a USB connection.

The output voltage required by the LED strings connected to the output channels is derived from a single input rail and continuously adjusted to minimize the voltage drop (and power dissipation) across them, despite an independent PWM duty cycle for each one. The brightness of each LED string is digitally controlled with 12- or 16-bit dimming resolution.

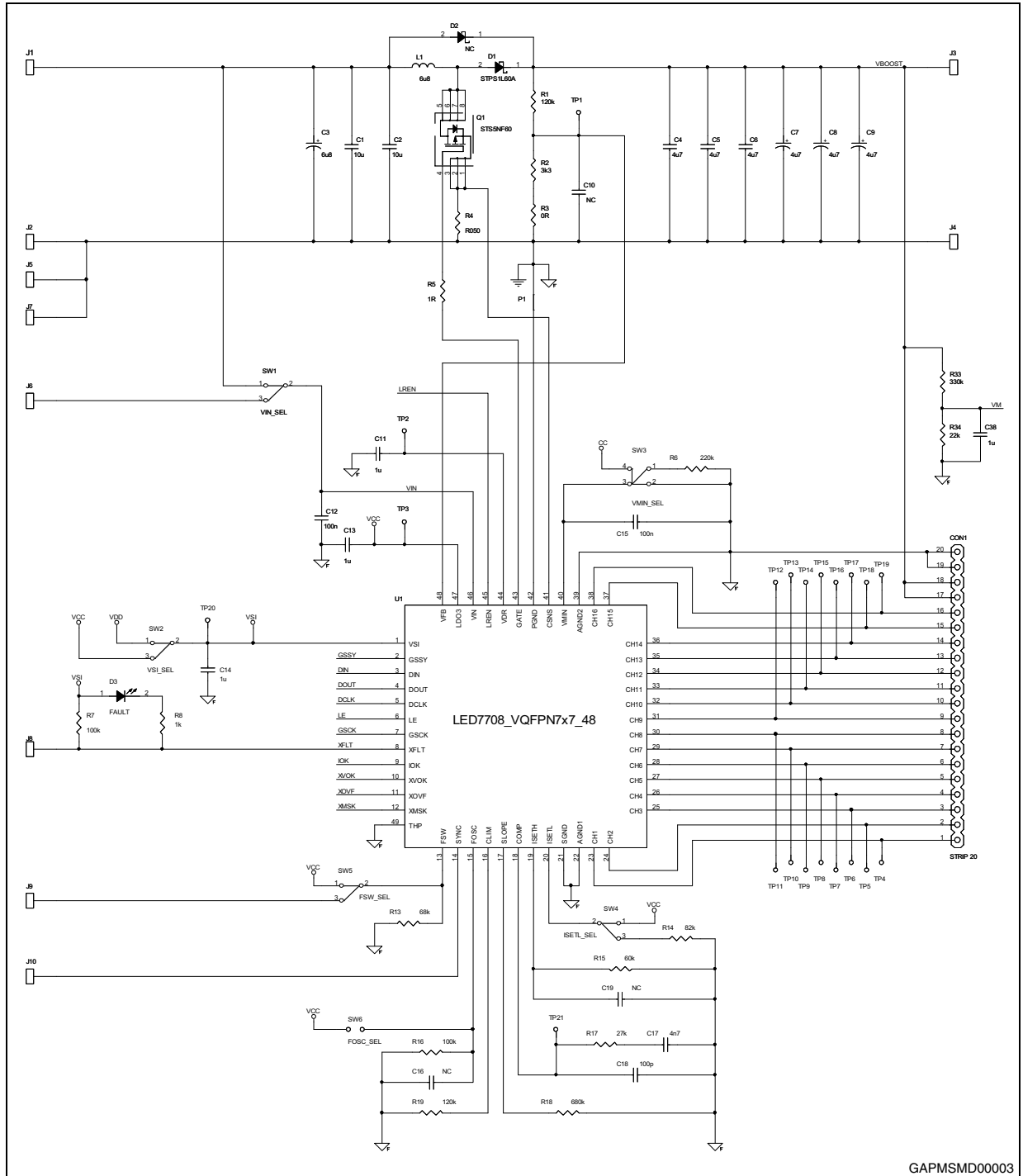


Embedded, programmable fault detection and management circuitry can be set to automatically disconnect faulty channels without the need for intervention by the host controller.

The board has been designed as a demonstration of a solution for medium/large LCD panel backlight drivers, but is suitable for any application involving several LEDs assembled in strings (e.g. advertisement panels, signs, gaming, etc.).

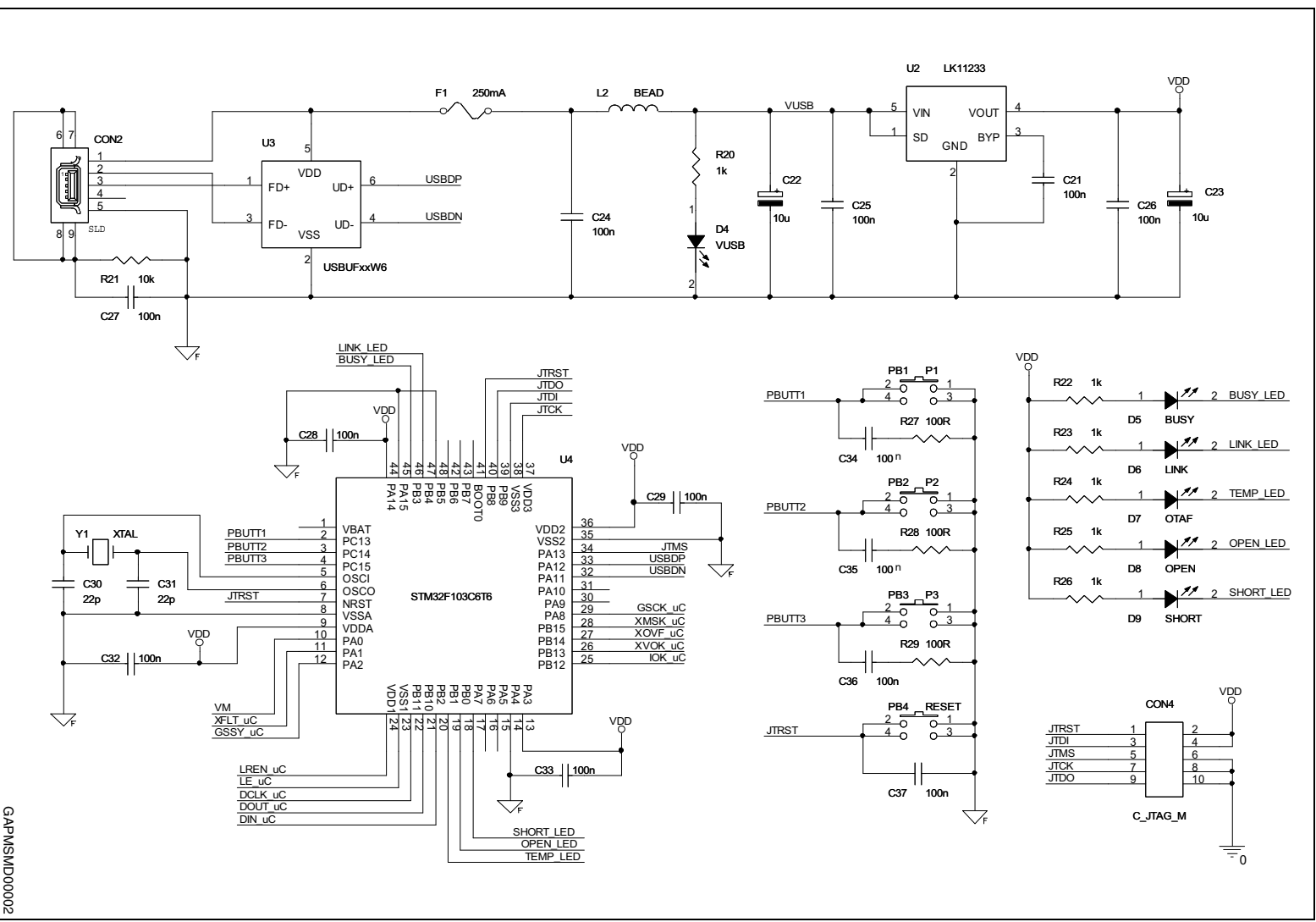
1 Schematic diagrams

Figure 1. LED driver



GAPMSMD00003

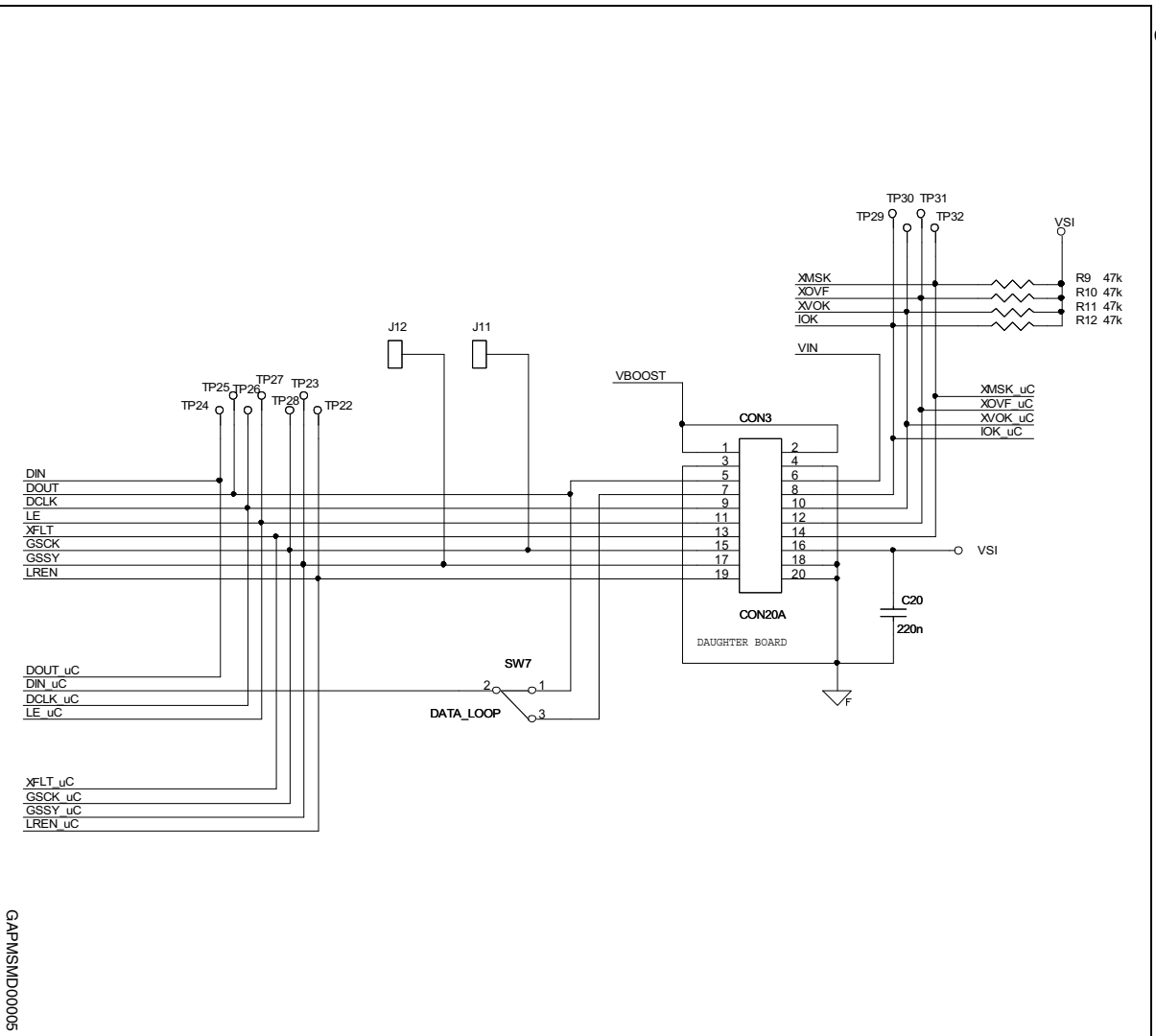
Figure 2. STM32 controller



GAPM5MID00002

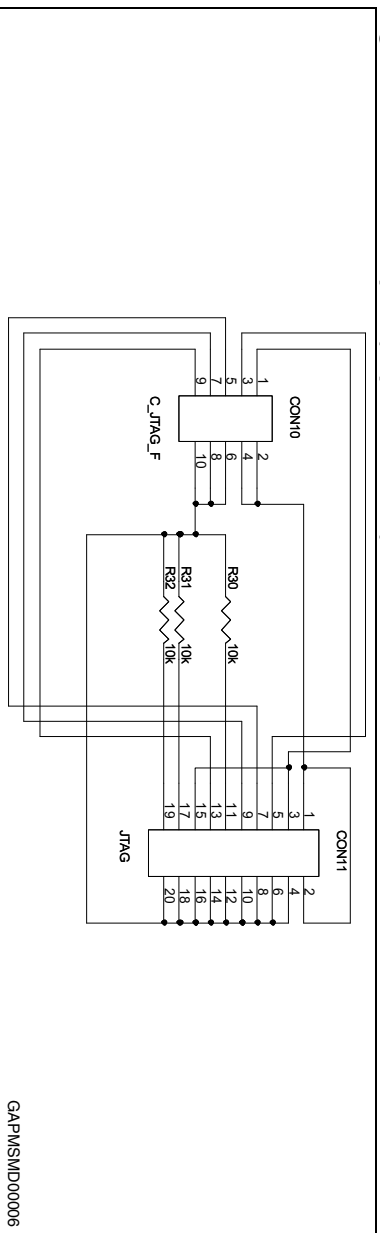


Figure 3. Connector



GAPFMSMD000005

Figure 4. JTAG adapter (separated PCB)



GAPFMSMD000006

2 Revision history

Table 1. Document revision history

Date	Revision	Changes
04-Jun-2012	1	Initial release.

Please Read Carefully:

Information in this document is provided solely in connection with ST products. STMicroelectronics NV and its subsidiaries ("ST") reserve the right to make changes, corrections, modifications or improvements, to this document, and the products and services described herein at any time, without notice.

All ST products are sold pursuant to ST's terms and conditions of sale.

Purchasers are solely responsible for the choice, selection and use of the ST products and services described herein, and ST assumes no liability whatsoever relating to the choice, selection or use of the ST products and services described herein.

No license, express or implied, by estoppel or otherwise, to any intellectual property rights is granted under this document. If any part of this document refers to any third party products or services it shall not be deemed a license grant by ST for the use of such third party products or services, or any intellectual property contained therein or considered as a warranty covering the use in any manner whatsoever of such third party products or services or any intellectual property contained therein.

UNLESS OTHERWISE SET FORTH IN ST'S TERMS AND CONDITIONS OF SALE ST DISCLAIMS ANY EXPRESS OR IMPLIED WARRANTY WITH RESPECT TO THE USE AND/OR SALE OF ST PRODUCTS INCLUDING WITHOUT LIMITATION IMPLIED WARRANTIES OF MERCHANTABILITY, FITNESS FOR A PARTICULAR PURPOSE (AND THEIR EQUIVALENTS UNDER THE LAWS OF ANY JURISDICTION), OR INFRINGEMENT OF ANY PATENT, COPYRIGHT OR OTHER INTELLECTUAL PROPERTY RIGHT.

UNLESS EXPRESSLY APPROVED IN WRITING BY TWO AUTHORIZED ST REPRESENTATIVES, ST PRODUCTS ARE NOT RECOMMENDED, AUTHORIZED OR WARRANTED FOR USE IN MILITARY, AIR CRAFT, SPACE, LIFE SAVING, OR LIFE SUSTAINING APPLICATIONS, NOR IN PRODUCTS OR SYSTEMS WHERE FAILURE OR MALFUNCTION MAY RESULT IN PERSONAL INJURY, DEATH, OR SEVERE PROPERTY OR ENVIRONMENTAL DAMAGE. ST PRODUCTS WHICH ARE NOT SPECIFIED AS "AUTOMOTIVE GRADE" MAY ONLY BE USED IN AUTOMOTIVE APPLICATIONS AT USER'S OWN RISK.

Resale of ST products with provisions different from the statements and/or technical features set forth in this document shall immediately void any warranty granted by ST for the ST product or service described herein and shall not create or extend in any manner whatsoever, any liability of ST.

ST and the ST logo are trademarks or registered trademarks of ST in various countries.

Information in this document supersedes and replaces all information previously supplied.

The ST logo is a registered trademark of STMicroelectronics. All other names are the property of their respective owners.

© 2012 STMicroelectronics - All rights reserved

STMicroelectronics group of companies

Australia - Belgium - Brazil - Canada - China - Czech Republic - Finland - France - Germany - Hong Kong - India - Israel - Italy - Japan - Malaysia - Malta - Morocco - Philippines - Singapore - Spain - Sweden - Switzerland - United Kingdom - United States of America

www.st.com