



Chipsmall Limited consists of a professional team with an average of over 10 year of expertise in the distribution of electronic components. Based in Hongkong, we have already established firm and mutual-benefit business relationships with customers from,Europe,America and south Asia,supplying obsolete and hard-to-find components to meet their specific needs.

With the principle of “Quality Parts,Customers Priority,Honest Operation,and Considerate Service”,our business mainly focus on the distribution of electronic components. Line cards we deal with include Microchip,ALPS,ROHM,Xilinx,Pulse,ON,Everlight and Freescale. Main products comprise IC,Modules,Potentiometer,IC Socket,Relay,Connector.Our parts cover such applications as commercial,industrial, and automotives areas.

We are looking forward to setting up business relationship with you and hope to provide you with the best service and solution. Let us make a better world for our industry!



## Contact us

Tel: +86-755-8981 8866 Fax: +86-755-8427 6832

Email & Skype: info@chipsmall.com Web: www.chipsmall.com

Address: A1208, Overseas Decoration Building, #122 Zhenhua RD., Futian, Shenzhen, China



# LED770x LED drivers

## New monolithic step-up family driving LEDs for backlighting and lighting



The LED770x family features two monolithic, high-efficiency LED drivers specifically designed to supply LED arrays used in the backlighting of LCD panels and general lighting. The drivers consist of a boost converter and six integrated PWM-dimmable current generators that give excellent dimming performance, and are housed in small VFQFPN4x4-24L packages.

Additional flexibility is guaranteed by a wide range of adjustable protection systems and thresholds, together with complete and flexible fault management, a wide input voltage range (from 4.5 V up to 36 V) and high switching frequency, to reduce size and cost of the total application.

### Key features

- 4.5 to 36 V input voltage range
- Six rows of up to 10 WLEDs each, with adjustable maximum current:
  - 30 mA max for LED7706
  - 85 mA max for LED7707
- Internal power MOSFET
- Housed in compact QFN 4x4 24L package
- 200 kHz to 1 MHz switching frequency
- External synchronization for multi-device applications
- Row disable option
- Soft-start, programmable OVP, thermal shutdown
- Ceramic output capacitor supported
- Parallelable rows
- $\pm 2\%$  current matching
- LED failure (open and short circuit) detection
- Less than 500  $\mu\text{s}$  minimum dimming time (1% minimum dimming duty-cycle at 20 kHz)  
Less than 10  $\mu\text{s}$  for LED7707

### Key benefits

- Monolithic and flexible solution
- High efficiency
- Superior dimming capability
- Complete and flexible fault management

### Targeted applications

- Consumer: mid to large size LCD TVs, monitors, portable entertainment
- Automotive: navigation displays and dashboards
- Industrial: lighting, displays, e-signage

## Application diagram

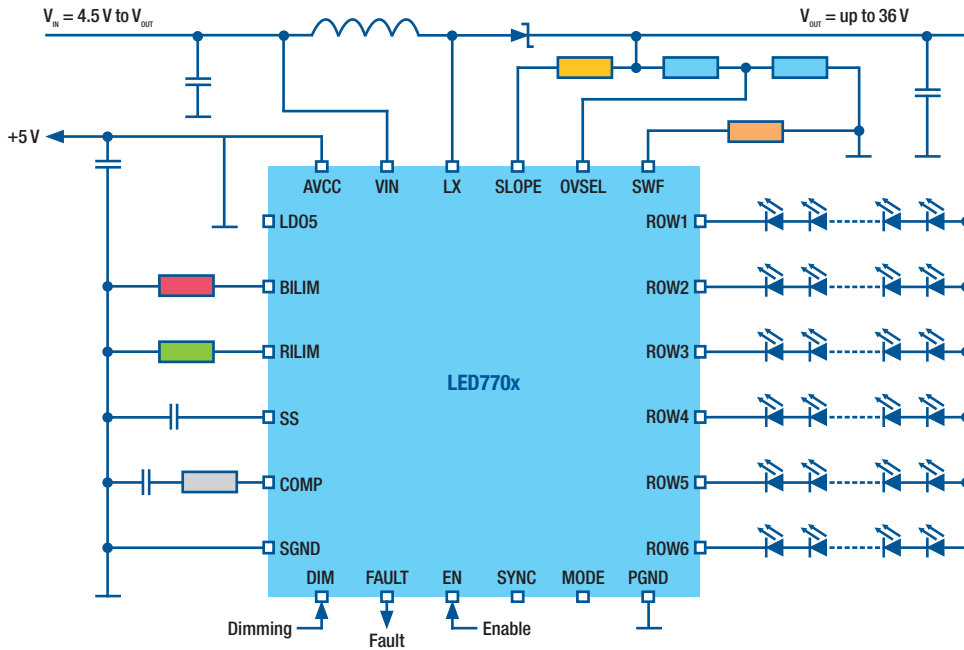

LED770x simplified application circuit

## Device description

The LED770x is a monolithic LED driver family for backlighting of LCD panels and lighting. The two devices consist of a boost converter and six integrated PWM-dimmable current generators. The boost section is based on a constant switching-frequency, peak current-mode architecture. The devices keep the lowest row's voltage regulated at the internal reference voltage, and adapt the boost output voltage to reduce power losses across the current generators. The boost-converter switching frequency is fixed at 630 kHz. This is a good compromise in terms of efficiency, size and cost of the power elements and of the overall application, but it can also be set anywhere in the 200 kHz to 1 MHz range by simply connecting a resistor to SGND, if more flexibility is required.

The LED770x devices, with their input voltage range from 4.5 V up to the output voltage, cover the most common voltage buses (5 V, 12 V and 24 V). In addition, an internal LDO supplies the internal circuitry of the device and is capable to deliver up to 40 mA. The generators can be externally programmed by using a single resistor to sink up to 30 mA or 85 mA (LED7707), and can be dimmed via a PWM signal. The devices detect and manage open and shorted LED faults, and leave unused rows floating, keeping extremely high flexibility for the final application. Basic protection (adjustable output overvoltage, adjustable internal MOSFET overcurrent and thermal shutdown) are also provided.

## LED770x product table

Part number	V <sub>in</sub> (V)	V <sub>out</sub> (V)	I <sub>rows</sub> (mA)	Rows	Min dimming time	Max LEDs per row	Fsw (kHz)	Package
LED7706	4.5 to 36	Up to 36	Up to 30	6	500 ns	10 (white)	200 to 1000	VFQFPN4x4-24L
LED7707	4.5 to 36	Up to 36	Up to 85	6	10 µs	10 (white)	200 to 1000	VFQFPN4x4-24L

## Evaluation boards

Part number	Description	Related documentation
STEVAL-ILL020V1	LED7706: 6-row, 30 mA LED driver with boost converter	AN2809
STEVAL-ILL021V1	LED7707: 6-row, 85 mA LED driver with boost converter	AN2810



© STMicroelectronics - February 2010 - Printed in Italy - All rights reserved

The STMicroelectronics corporate logo is a registered trademark of the STMicroelectronics group of companies.  
All other names are the property of their respective owners.

For more information on ST products and solutions,  
visit [www.st.com](http://www.st.com)