



Chipsmall Limited consists of a professional team with an average of over 10 year of expertise in the distribution of electronic components. Based in Hongkong, we have already established firm and mutual-benefit business relationships with customers from,Europe,America and south Asia,supplying obsolete and hard-to-find components to meet their specific needs.

With the principle of “Quality Parts,Customers Priority,Honest Operation,and Considerate Service”,our business mainly focus on the distribution of electronic components. Line cards we deal with include Microchip,ALPS,ROHM,Xilinx,Pulse,ON,Everlight and Freescale. Main products comprise IC,Modules,Potentiometer,IC Socket,Relay,Connector.Our parts cover such applications as commercial,industrial, and automotives areas.

We are looking forward to setting up business relationship with you and hope to provide you with the best service and solution. Let us make a better world for our industry!



Contact us

Tel: +86-755-8981 8866 Fax: +86-755-8427 6832

Email & Skype: info@chipsmall.com Web: www.chipsmall.com

Address: A1208, Overseas Decoration Building, #122 Zhenhua RD., Futian, Shenzhen, China



Six-channel ALED7707-based LED driver with embedded boost converter for automotive interior lighting and TFT backlighting

Data brief



Description

The purpose of this evaluation board is to provide an application example of a six-channel, medium-current LED driver using the ALED7707 chip. The monolithic boost converter provides the required LED supply voltage starting from a single supply rail, while the brightness of the LED strings connected to the six outputs is controlled through a PWM signal. Open LED and LED short-circuit fault conditions are detected and managed.

The board has been designed to provide a compact reference solution for automotive applications involving several LEDs arranged in multiple strings (e.g. interior lighting, infotainment LCD backlighting, etc.).

Features

- Wide DC input voltage (6 V - 32 V)
- Six 70 mA output channels (capable of 30 mA to 85 mA each)
- PWM brightness control (10 μ s minimum dimming on-time)
- Up to 10 white LEDs per channel (36 V OVP threshold)
- > 90% efficiency ($V_{IN}=12$ V, $V_{BOOST}=30$ V, $f_{sw}=1$ MHz, no snubber)
- On-board input filter for conducted EMI reduction
- RoHS compliant
- All automotive-grade components

1 Board description and efficiency measurement

Figure 1: Basic connection of the STEVAL-ILL067V1 evaluation board

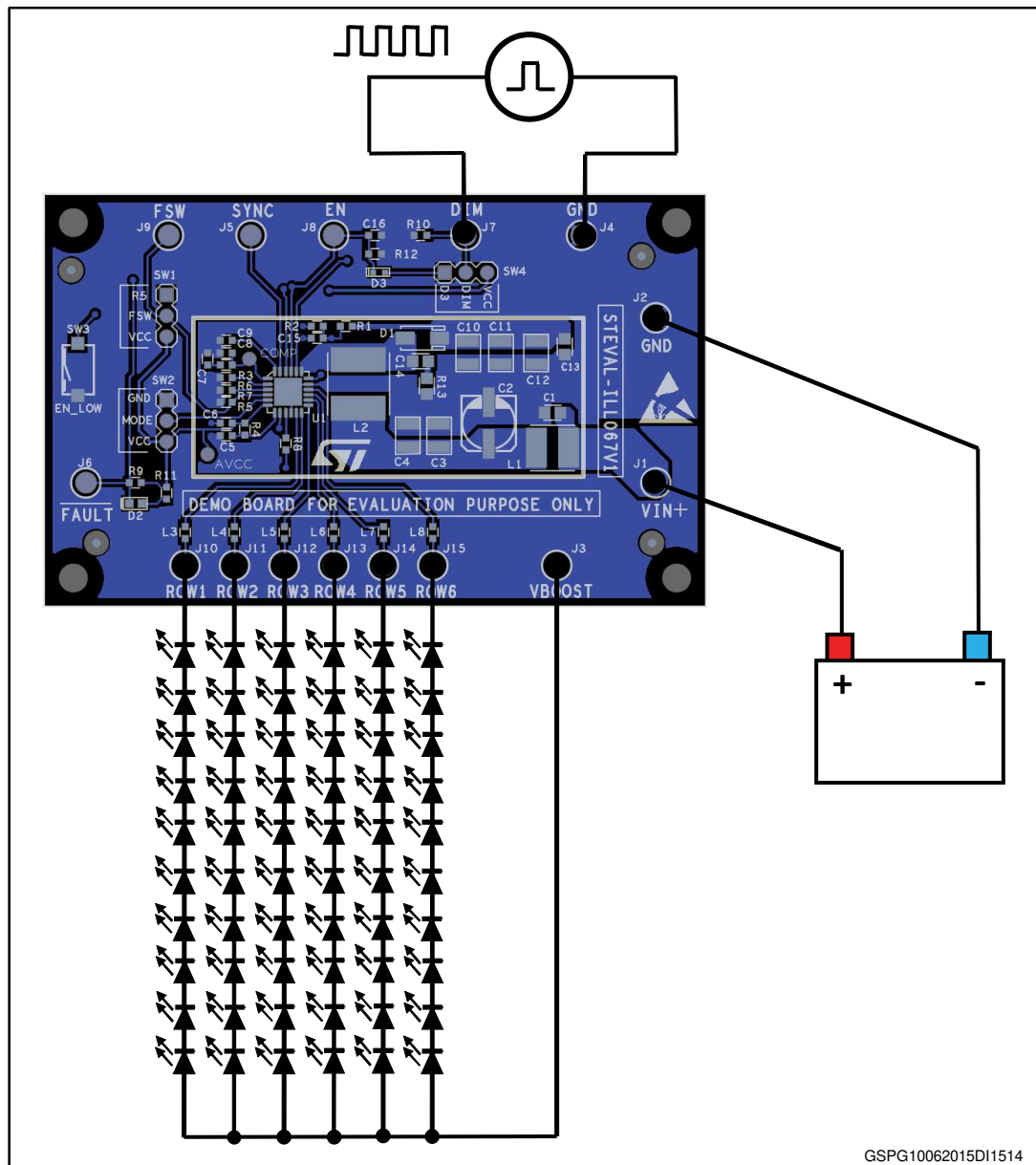

For a quick evaluation of the STEVAL-ILL067V1 performance, just connect a DC power supply (e.g. 12 V & 3 A current capability) between the V_{IN} (J1) and GND (J2) terminals and a set of suitable LED strings between the V_{BOOST} (J3) & ROW1-ROW6 (J10 through J15) terminals. The SW1 & SW2 jumpers should be both set in the lower position, while the SW4 jumper should be in the right position (FSW & MODE pins forced high, DIM pin high, see Table 3 for details) as per default setting. As soon as the supply input is powered, the EN pin (floating) is internally pulled-up, a soft-start sequence takes place and the LED strings are powered at full-brightness. By pressing SW3 (EN pin tied low), the device shuts-down. This pushbutton allows to easily reset the device in case a latched turn-off occurs as

a consequence of a faulty condition (LED short-circuit, open string). To evaluate the PWM dimming capability, simply connect a pulse generator between the DIM terminal and ground (see figure 1) and remove the SW4 jumper to avoid any conflict between the external PWM signal and the +5 V rail. The frequency of the PWM signal should be in the 100 Hz - 20 kHz range, with a 10us minimum pulse duration and a 3.0 V to 5 V amplitude.

Figure 2: STEVAL-ILL067V1 evaluation board PCB, top view

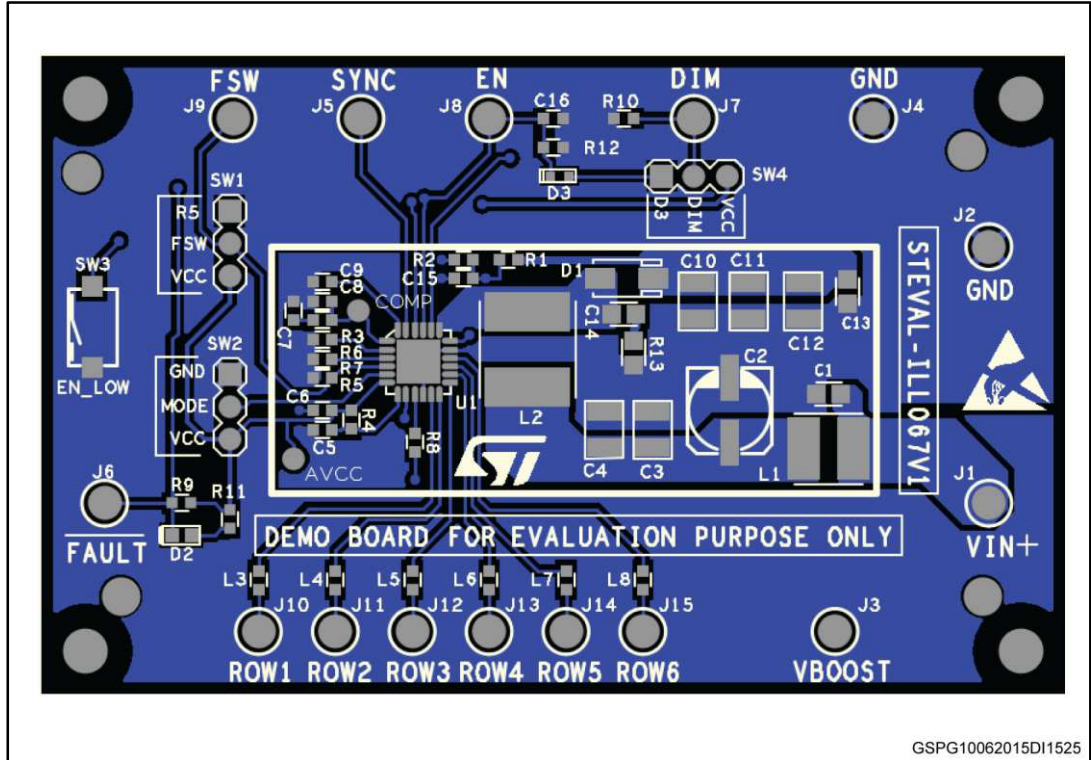
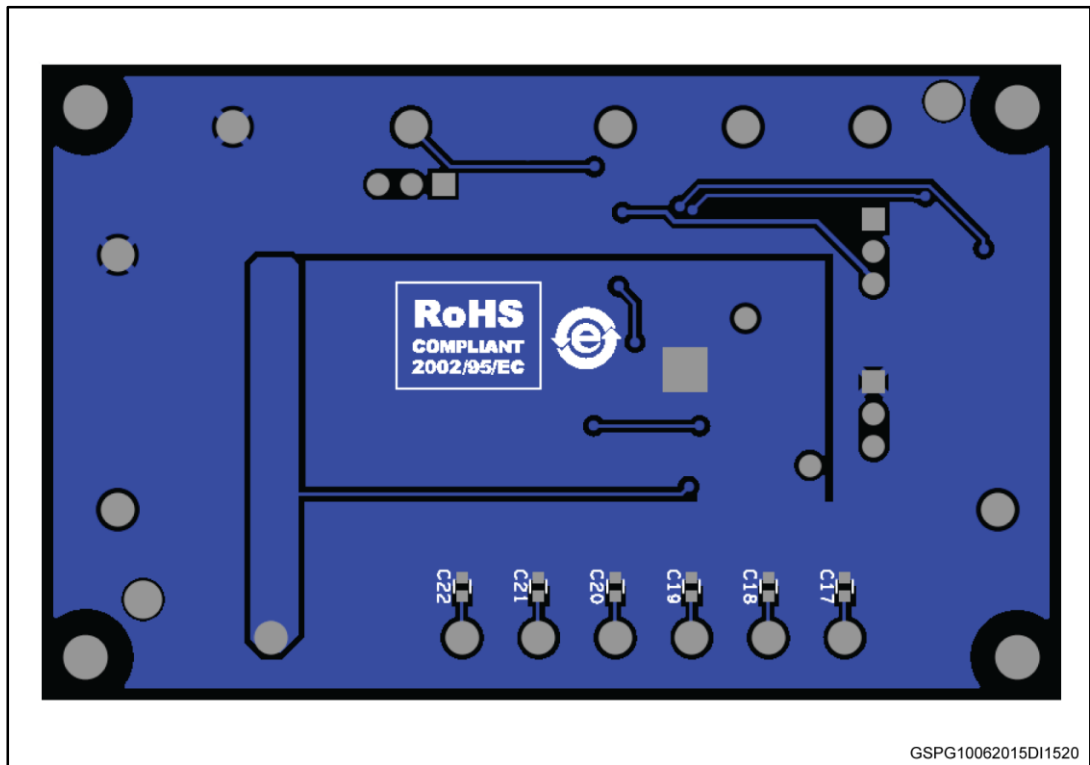

Figure 3: STEVAL-ILL067V1 evaluation board PCB, bottom view



GSPG10062015DI1520

Table 1: STEVAL-ILL067V1 connectors

Connector	Name	Function
J1	VIN+	Power supply input, positive terminal
J2	GND	Ground. This terminal has to be preferred as return for the power supply input.
J3	VBOOST	Boost converter output. Connect this terminal to the common anode of the LED strings to be driven.
J4	GND	Quiet ground terminal. To be used as reference ground for all control signals.
J5	SYNC	Switching frequency synchronization output. A synchronization clock is available at this pin.
J6	FAULT	Faulty condition indicator. Open drain output, tied low by the device when a faulty condition is detected. Also used to drive the D2 LED.
J7	DIM	PWM dimming control input. The output current generators are activated according to this pin to perform a PWM brightness control of the LEDs.
J8	EN	Device Enable input. Internally pulled-up. If tied low the device turns-off.
J9	FSW	Switching frequency synchronization input. An external clock (30% max duty-cycle) can be provided at this terminal to synchronize the boost converter.
J10	ROW1	
J11	ROW2	Output terminals (channels). A low-side current generator is connected to each output. Connect to the cathode of the LED strings. Unused channels can be left floating.
J12	ROW3	
J13	ROW4	

Connector	Name	Function
J14	ROW5	
J15	ROW6	

Table 2: STEVAL-ILL067V1 test points

Test point	Function
AVCC	+5 V LDO output monitor (device supply rail).
COMP	COMP pin monitor (output of the trans-conductance amplifier of the control loop).

Table 3: STEVAL-ILL067V1 jumpers and switches

Jumper / switch	Function
SW1	FSW pin assignment. When the jumper is set in the upper position (FSW to R5), the switching frequency of the boost converter is set by R5 (1 MHz). In the lower position (FSW to VCC), the FSW pin is tied high and the 630 kHz fixed switching frequency is set. In case an external synchronization clock has to be applied at the FSW pin, this jumper must be in the upper position.
SW2	MODE pin setting. This jumper allows to set high (VCC) or low (GND) the MODE pin in order to select the desired LED fault management. In case some channels are not used, the MODE pin must be set high.
SW3	EN low pushbutton. When pressed the EN pin (internally pulled-up) is tied to ground. Used to restart the device in case a latched turn-off due to a faulty condition.
SW4	DIM pin setting. If the jumper is set in the right position (VCC), the DIM pin is held high and the LEDs are driven at full-brightness as soon as the EN pin goes high. If the jumper is set in the left position (D3), the EN pin is pulled-down by R12 and activated by the PWM signal applied at the DIM pin through D3. This way a single-wire control is achieved (automatic device turn-on as soon as PWM dimming is applied). Note: D3 (BAT54K) & R12 (220k) are natively not mounted.

Figure 4: STEVAL-ILL067V1 efficiency (fsw=1 MHz)

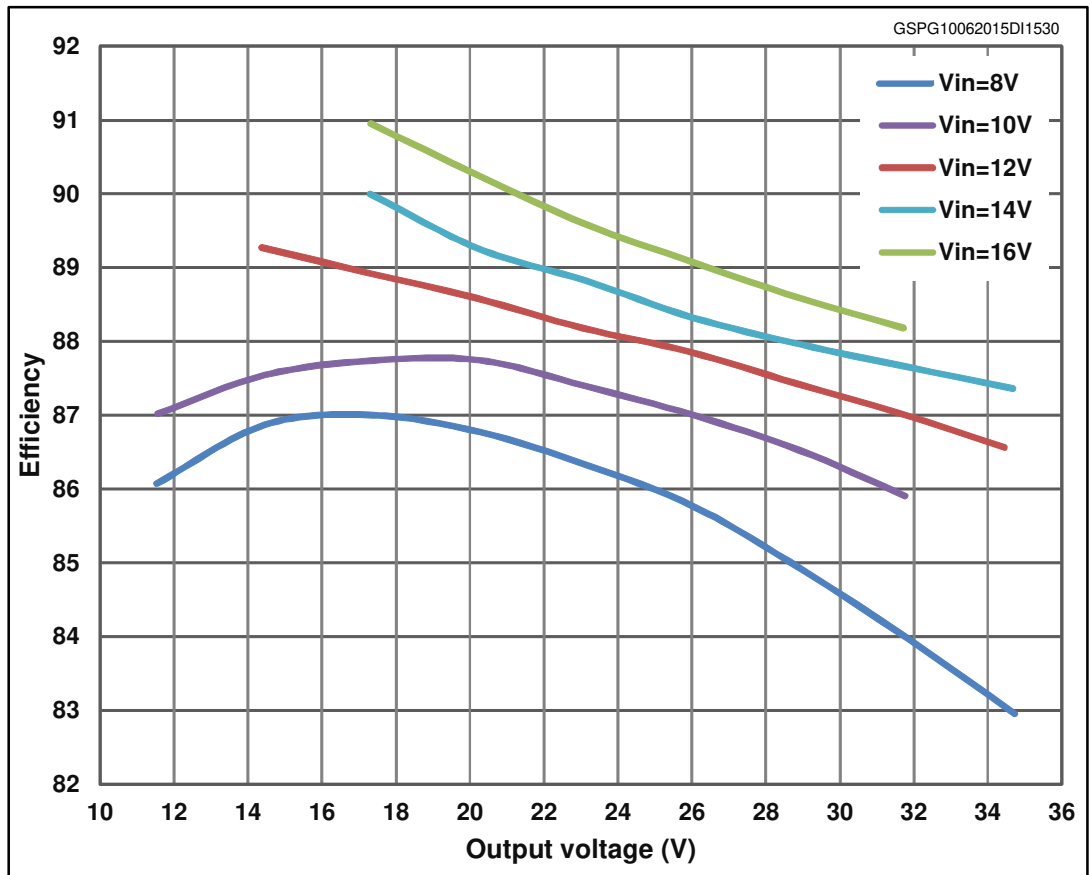
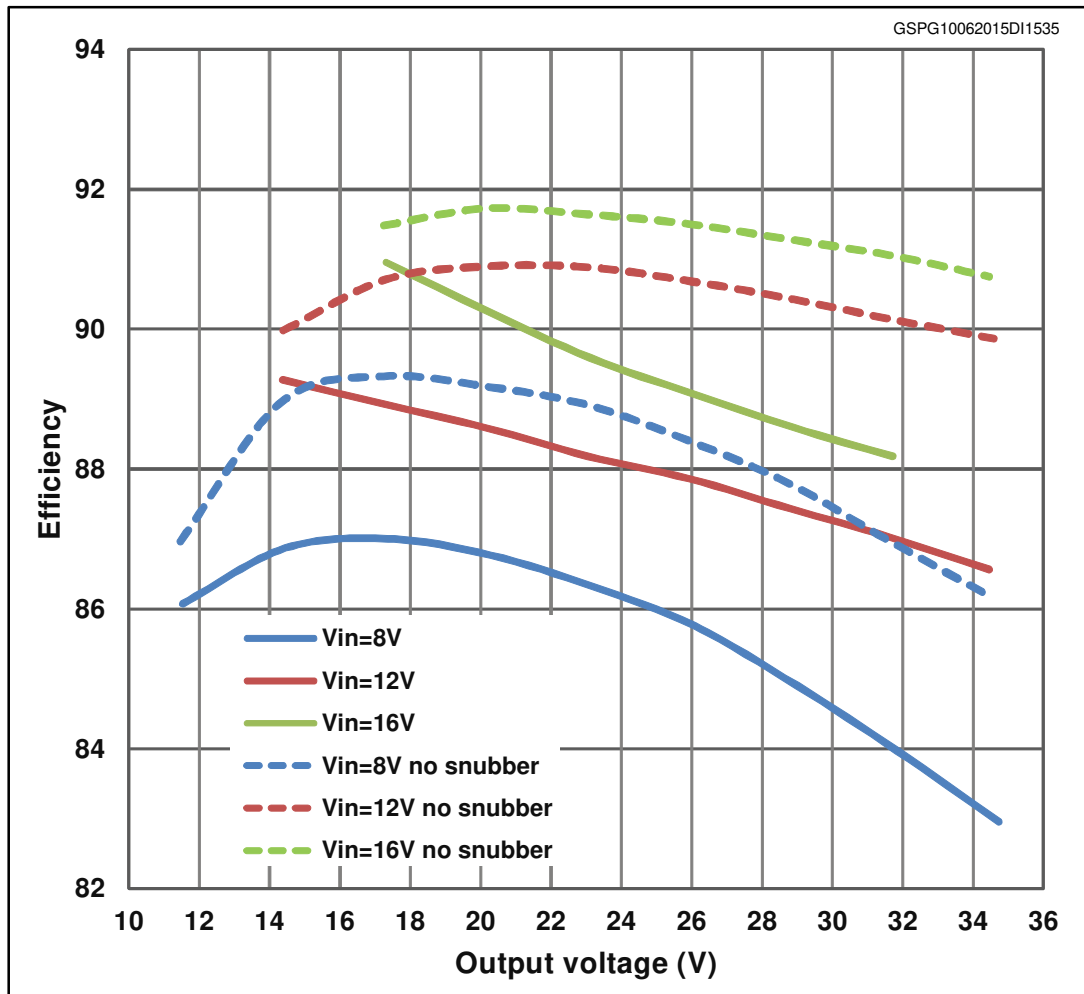

Figure 5: STEVAL-ILL067V1 efficiency with and w/o the R13-C14 snubber (fsw=1 MHz)



2 Schematic diagram

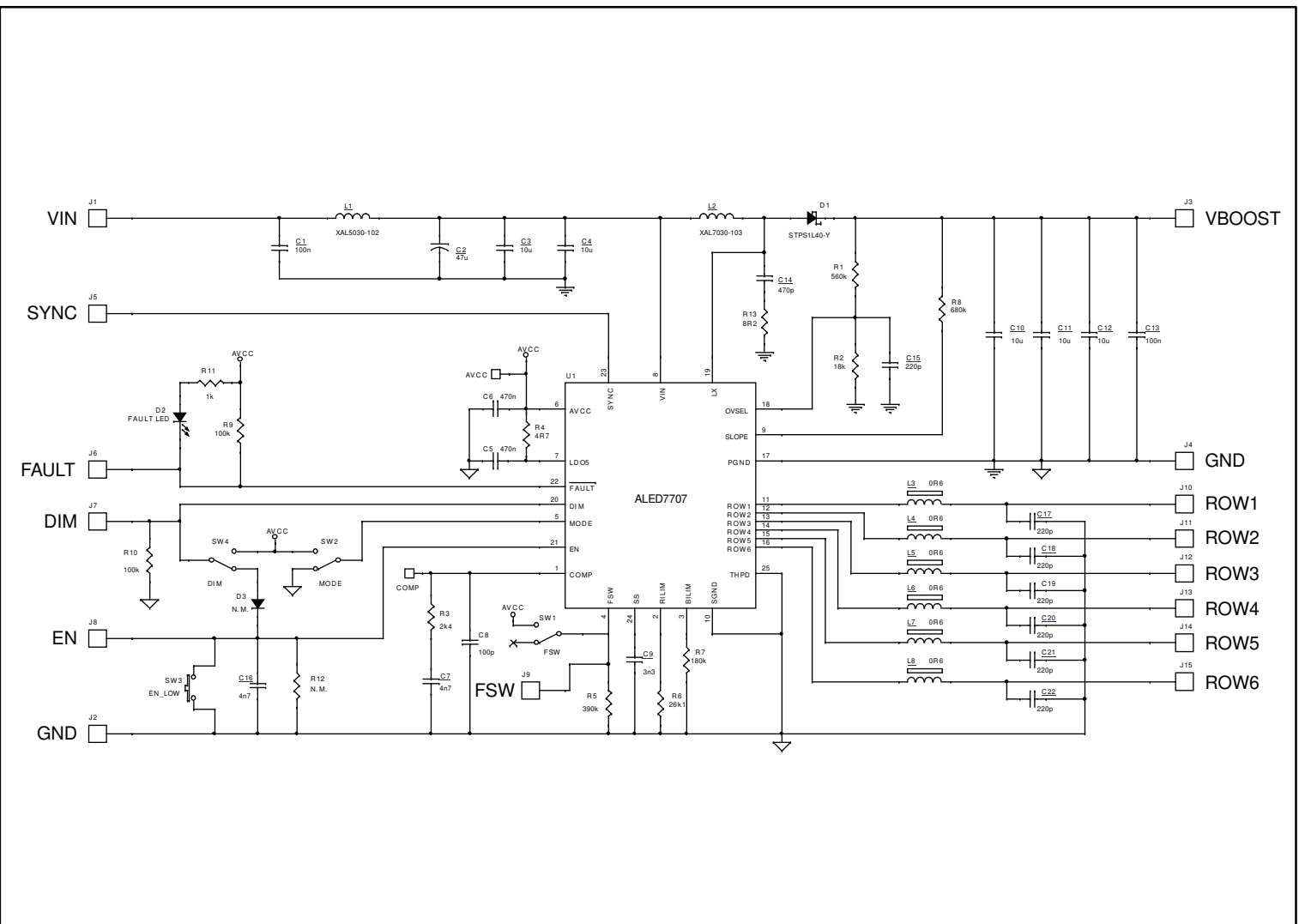

Figure 6: STEVAL-ILL067V1 circuit schematic



3 Revision history

Table 4: Document revision history

Date	Version	Changes
12-Jun-2015	1	Initial release.

IMPORTANT NOTICE – PLEASE READ CAREFULLY

STMicroelectronics NV and its subsidiaries ("ST") reserve the right to make changes, corrections, enhancements, modifications, and improvements to ST products and/or to this document at any time without notice. Purchasers should obtain the latest relevant information on ST products before placing orders. ST products are sold pursuant to ST's terms and conditions of sale in place at the time of order acknowledgement.

Purchasers are solely responsible for the choice, selection, and use of ST products and ST assumes no liability for application assistance or the design of Purchasers' products.

No license, express or implied, to any intellectual property right is granted by ST herein.

Resale of ST products with provisions different from the information set forth herein shall void any warranty granted by ST for such product.

ST and the ST logo are trademarks of ST. All other product or service names are the property of their respective owners.

Information in this document supersedes and replaces information previously supplied in any prior versions of this document.

© 2015 STMicroelectronics – All rights reserved