



Chipsmall Limited consists of a professional team with an average of over 10 year of expertise in the distribution of electronic components. Based in Hongkong, we have already established firm and mutual-benefit business relationships with customers from,Europe,America and south Asia,supplying obsolete and hard-to-find components to meet their specific needs.

With the principle of “Quality Parts,Customers Priority,Honest Operation,and Considerate Service”,our business mainly focus on the distribution of electronic components. Line cards we deal with include Microchip,ALPS,ROHM,Xilinx,Pulse,ON,Everlight and Freescale. Main products comprise IC,Modules,Potentiometer,IC Socket,Relay,Connector.Our parts cover such applications as commercial,industrial, and automotives areas.

We are looking forward to setting up business relationship with you and hope to provide you with the best service and solution. Let us make a better world for our industry!



Contact us

Tel: +86-755-8981 8866 Fax: +86-755-8427 6832

Email & Skype: info@chipsmall.com Web: www.chipsmall.com

Address: A1208, Overseas Decoration Building, #122 Zhenhua RD., Futian, Shenzhen, China



35W single string LED driver using HVLED001

Data brief

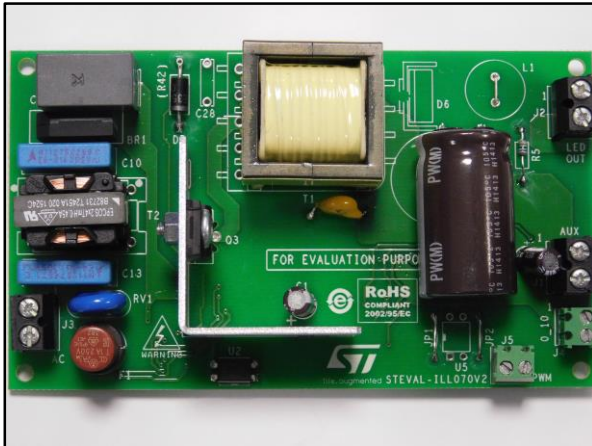

Features

- Input voltage: V_{IN} : 90 - 265 V_{RMS} , f: 45-66 Hz
- Output current: 700 mA ($V_{LED} = 24$ V to 48 V)
- Dimming: 100% to 10% (any condition)
- Dimming interfaces: 0-10 V and PWM input
- High power factor, low THD
- Efficiency: > 90% @ full load
- Open load voltage limiting
- RoHS compliant

Description

The STEVAL-ILL070V2 is intended to drive a single LED string with a maximum output current of 700 mA. The LED current can be adjusted using either a 0-10 V interface or a PWM signal (for example provided by a microcontroller) on the SELV portion of the board. The universal input capability makes this board suitable in worldwide designs. An auxiliary 12 V output is also present to supply small circuitries (e.g., a potentiometer to drive the 0-10 V input) providing a maximum current of 10 mA. Input voltage variations, excessive input voltage (overvoltage, like surges or bursts) or very low input voltages are managed by some of the protections of the HVLED001, improving the reliability of the application. Output open circuit and overload protections trigger auto-restart for safe operation in lighting environments.

1 Schematic diagram

Figure 1: STEVAL-ILL070V2 board schematic part 1

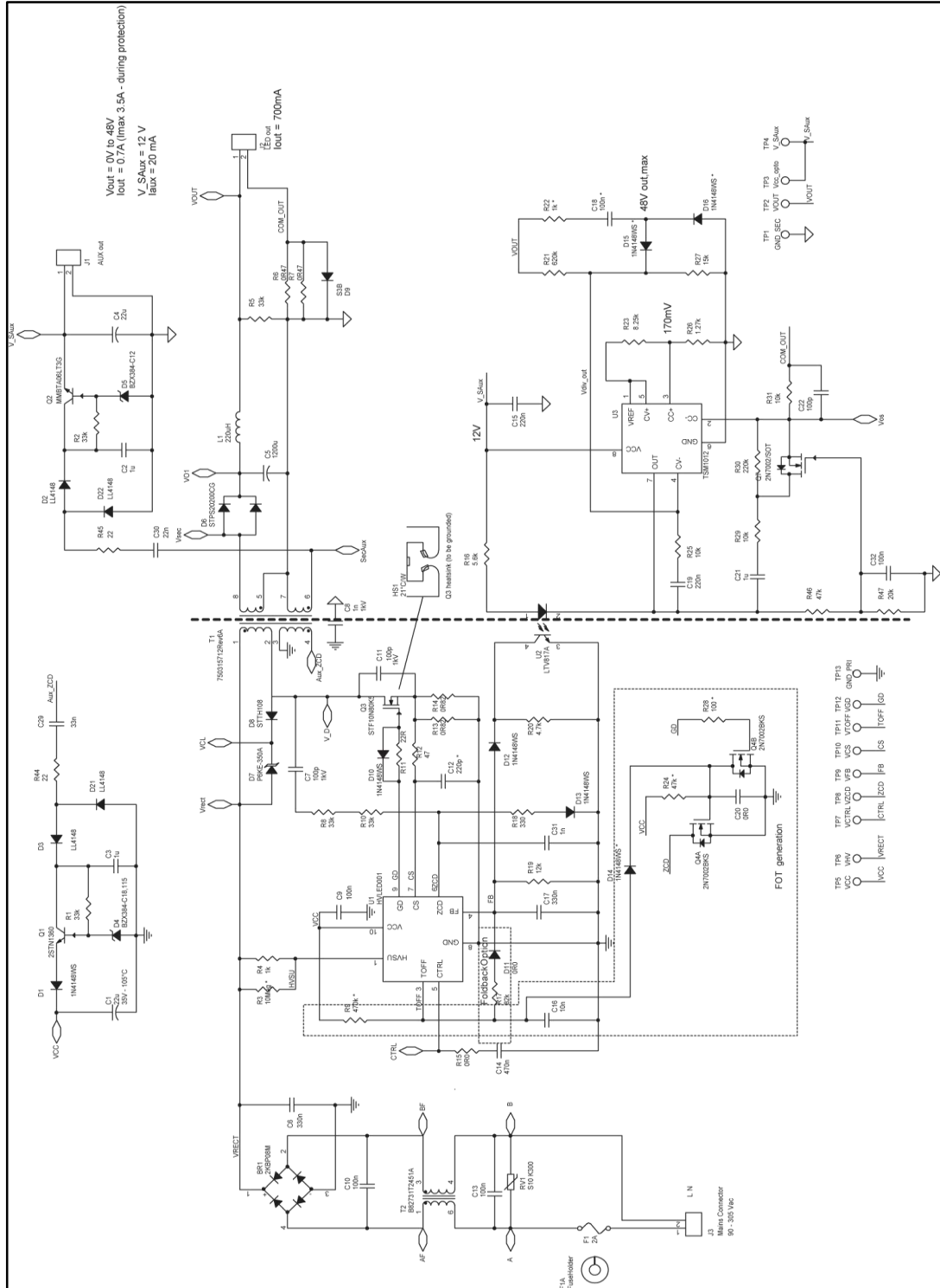

2 Revision history

Table 1: Document revision history

Date	Version	Changes
17-Feb-2016	1	Initial release.
01-Mar-2016	2	Figure 1: updated

IMPORTANT NOTICE – PLEASE READ CAREFULLY

STMicroelectronics NV and its subsidiaries ("ST") reserve the right to make changes, corrections, enhancements, modifications, and improvements to ST products and/or to this document at any time without notice. Purchasers should obtain the latest relevant information on ST products before placing orders. ST products are sold pursuant to ST's terms and conditions of sale in place at the time of order acknowledgement.

Purchasers are solely responsible for the choice, selection, and use of ST products and ST assumes no liability for application assistance or the design of Purchasers' products.

No license, express or implied, to any intellectual property right is granted by ST herein.

Resale of ST products with provisions different from the information set forth herein shall void any warranty granted by ST for such product.

ST and the ST logo are trademarks of ST. All other product or service names are the property of their respective owners.

Information in this document supersedes and replaces information previously supplied in any prior versions of this document.

© 2016 STMicroelectronics – All rights reserved