



Chipsmall Limited consists of a professional team with an average of over 10 year of expertise in the distribution of electronic components. Based in Hongkong, we have already established firm and mutual-benefit business relationships with customers from,Europe,America and south Asia,supplying obsolete and hard-to-find components to meet their specific needs.

With the principle of “Quality Parts,Customers Priority,Honest Operation,and Considerate Service”,our business mainly focus on the distribution of electronic components. Line cards we deal with include Microchip,ALPS,ROHM,Xilinx,Pulse,ON,Everlight and Freescale. Main products comprise IC,Modules,Potentiometer,IC Socket,Relay,Connector.Our parts cover such applications as commercial,industrial, and automotives areas.

We are looking forward to setting up business relationship with you and hope to provide you with the best service and solution. Let us make a better world for our industry!



## Contact us

Tel: +86-755-8981 8866 Fax: +86-755-8427 6832

Email & Skype: info@chipsmall.com Web: www.chipsmall.com

Address: A1208, Overseas Decoration Building, #122 Zhenhua RD., Futian, Shenzhen, China



## 60 W wide input range flyback converter using HVLED001A controller in FOT mode

Data brief

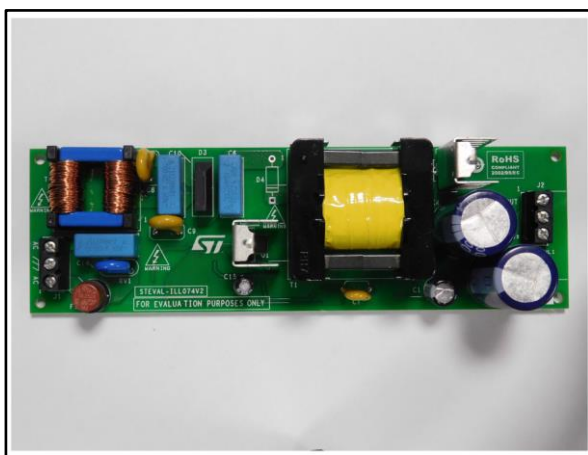

### Description

The STEVAL-ILL074V2 provides a stable, insulated 52 V voltage bus suitable for secondary side circuitry (e.g. LED current generators), for a total output power of 60 W given a wide range of input voltage range. An auxiliary 15 V output is also present to supply small circuitries absorbing a maximum current of 50 mA.

A very high power factor is obtained thanks to the features of the HVLED001A device. Input voltage variations, excessive input voltage (overvoltages like surges or bursts) and very low input voltages are managed by the HVLED001A protections, improving the reliability of the application.

Output short circuit and overload protections are available with auto-restart for safe operation in lighting environments.

### Features

- Input voltage:  $V_{in} = 90 - 277 V_{rms}$ ,  $f = 45-66$  Hz
- Output voltage: 52 V / 1.2 A
- High power factor, low THD
- Full load efficiency: above 90%
- Short circuit protection
- Safety: compliant with EN60065
- PCB board: 165 mm x 50 mm double-sided PCB
- RoHS compliant

# 1 Board circuit

Figure 1: Board connections

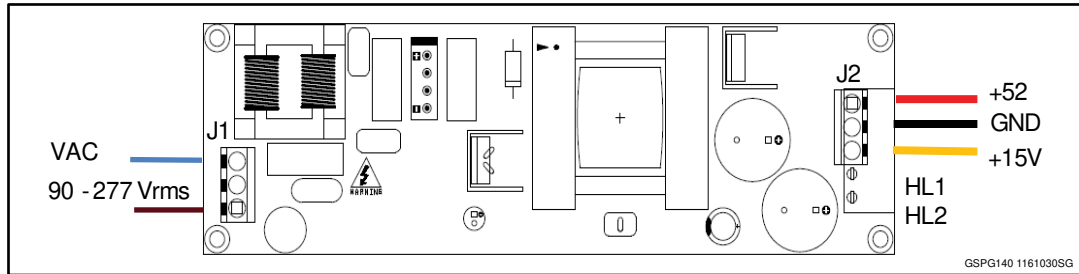

# 2 Schematic diagram

Figure 2: STEVAL-ILL074V2 circuit schematic

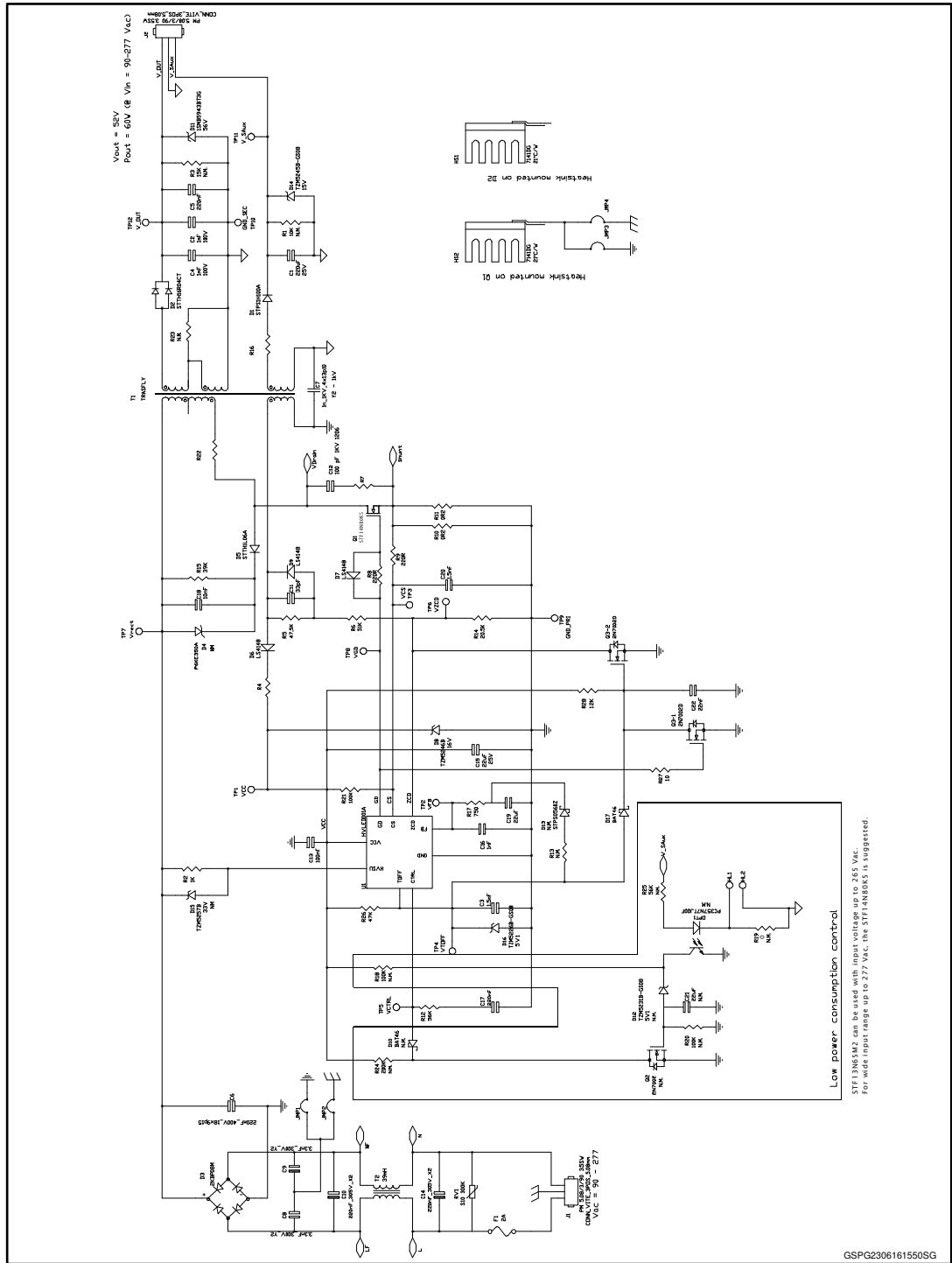

GSPG2306161550SG

### 3 Revision history

Table 1: Document revision history

Date	Version	Changes
18-Jan-2016	1	Initial release.
19-Feb-2016	2	Updated: title on the cover page and figure 2 STEVAL-ILL074V2 circuit schematic.
10-Mar-2016	3	Updated: Figure 2 STEVAL-ILL074V2 circuit schematic.
23-Jun-2016	4	Updated: Figure 2 STEVAL-ILL074V2 circuit schematic.
20-Feb-2017	5	Updated: <i>Figure 2: "STEVAL-ILL074V2 circuit schematic"</i> .



**IMPORTANT NOTICE – PLEASE READ CAREFULLY**

STMicroelectronics NV and its subsidiaries ("ST") reserve the right to make changes, corrections, enhancements, modifications, and improvements to ST products and/or to this document at any time without notice. Purchasers should obtain the latest relevant information on ST products before placing orders. ST products are sold pursuant to ST's terms and conditions of sale in place at the time of order acknowledgement.

Purchasers are solely responsible for the choice, selection, and use of ST products and ST assumes no liability for application assistance or the design of Purchasers' products.

No license, express or implied, to any intellectual property right is granted by ST herein.

Resale of ST products with provisions different from the information set forth herein shall void any warranty granted by ST for such product.

ST and the ST logo are trademarks of ST. All other product or service names are the property of their respective owners.

Information in this document supersedes and replaces information previously supplied in any prior versions of this document.

© 2017 STMicroelectronics – All rights reserved