



Chipsmall Limited consists of a professional team with an average of over 10 year of expertise in the distribution of electronic components. Based in Hongkong, we have already established firm and mutual-benefit business relationships with customers from,Europe,America and south Asia,supplying obsolete and hard-to-find components to meet their specific needs.

With the principle of “Quality Parts,Customers Priority,Honest Operation,and Considerate Service”,our business mainly focus on the distribution of electronic components. Line cards we deal with include Microchip,ALPS,ROHM,Xilinx,Pulse,ON,Everlight and Freescale. Main products comprise IC,Modules,Potentiometer,IC Socket,Relay,Connector.Our parts cover such applications as commercial,industrial, and automotives areas.

We are looking forward to setting up business relationship with you and hope to provide you with the best service and solution. Let us make a better world for our industry!



Contact us

Tel: +86-755-8981 8866 Fax: +86-755-8427 6832

Email & Skype: info@chipsmall.com Web: www.chipsmall.com

Address: A1208, Overseas Decoration Building, #122 Zhenhua RD., Futian, Shenzhen, China



0.55 A, positive buck-boost LED driver board based on LED6000

Data brief

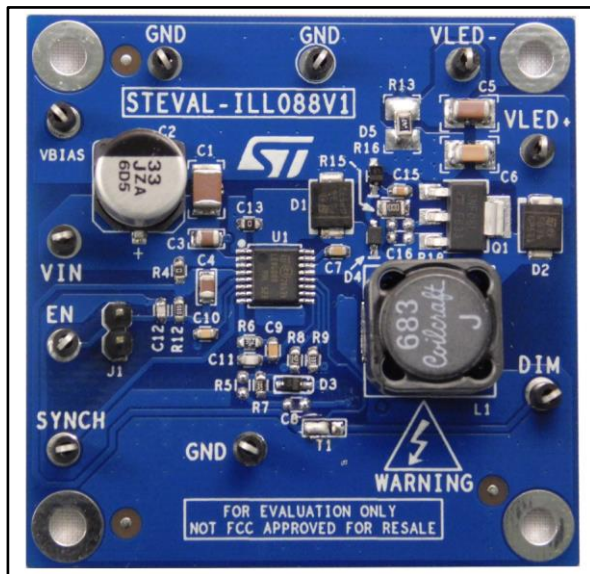

Features

- 24 to 60 V input voltage
- Step-up and step-down conversion (up to 14 LEDs)
- 0.55 A programmed LED current
- 500 kHz switching frequency
- Digital dimming
- Compatible with ceramic output capacitors
- 180° out-of-phase synchronization
- Auto-recovery overcurrent and thermal protection
- RoHS compliant

Description

The STEVAL-ILL088V1 evaluation board is based on a monolithic current source for high power LED driving, the LED6000, a 61 V asynchronous switching regulator. With embedded power MOSFET, it is designed to source up to 3 A DC current depending on the application conditions.

The 250 mV typical RSENSE voltage drop, the VBIAS pin embedded switch-over feature and the light load management (pulse skipping) maximize power conversion efficiency across the entire load range.

Digital dimming is implemented by driving the dedicated DIM pin.

The current limit threshold and the switching frequency are adjustable for application optimization.

The device also includes a 250 kHz oscillator that can be externally adjusted up to 1.5 MHz.

The size of the overall application is minimized thanks to the high switching frequency and its compatibility with ceramic output capacitors.

Two LED6000 regulators can be synchronized in a 180° out-of-phase configuration to reduce the total input RMS current.

1 Schematic diagram

Figure 1 : STEVAL-ILL088V1 circuit schematic

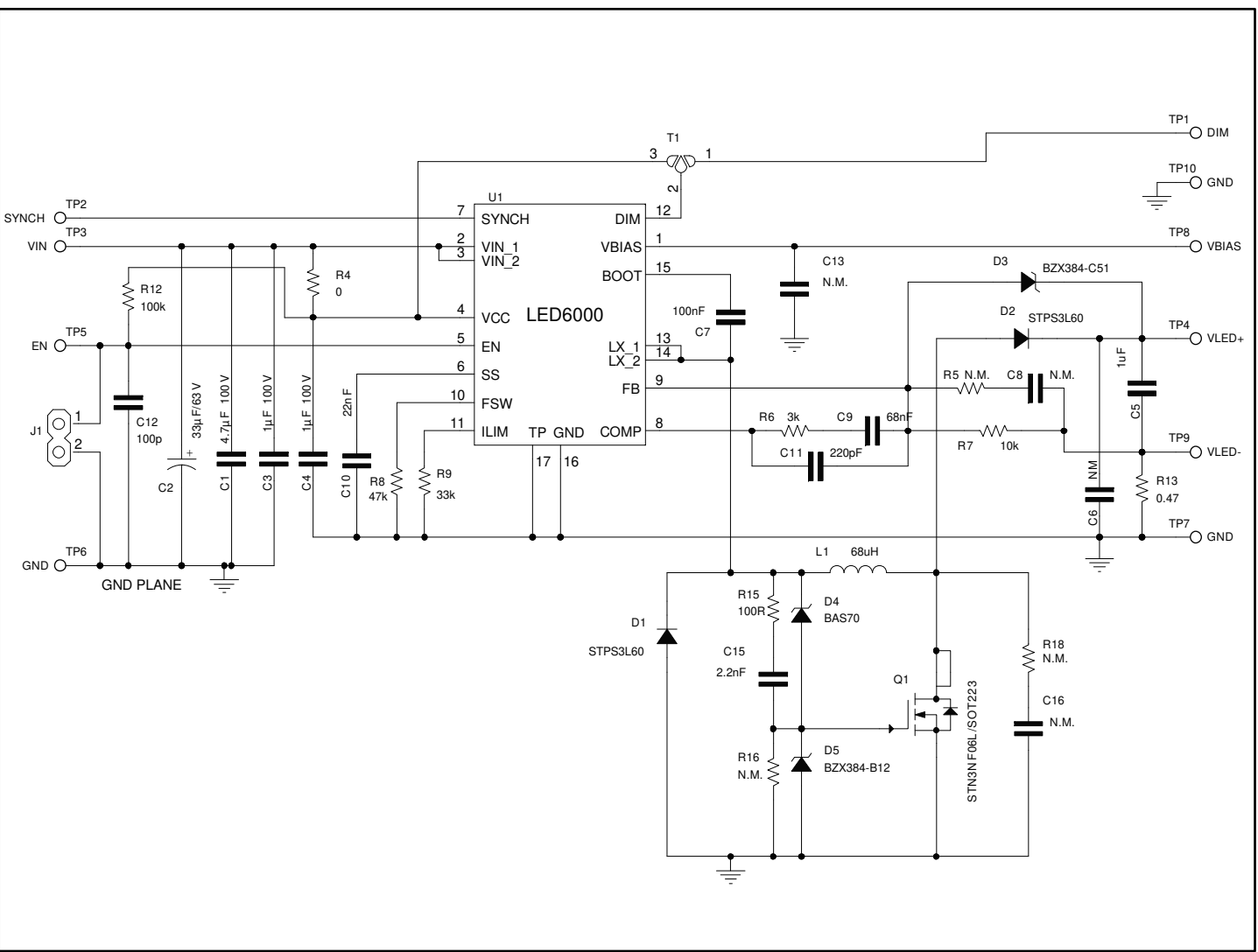

2 Revision history

Table 1: Document revision history

Date	Version	Changes
16-Feb-2017	1	Initial release.

IMPORTANT NOTICE – PLEASE READ CAREFULLY

STMicroelectronics NV and its subsidiaries ("ST") reserve the right to make changes, corrections, enhancements, modifications, and improvements to ST products and/or to this document at any time without notice. Purchasers should obtain the latest relevant information on ST products before placing orders. ST products are sold pursuant to ST's terms and conditions of sale in place at the time of order acknowledgement.

Purchasers are solely responsible for the choice, selection, and use of ST products and ST assumes no liability for application assistance or the design of Purchasers' products.

No license, express or implied, to any intellectual property right is granted by ST herein.

Resale of ST products with provisions different from the information set forth herein shall void any warranty granted by ST for such product.

ST and the ST logo are trademarks of ST. All other product or service names are the property of their respective owners.

Information in this document supersedes and replaces information previously supplied in any prior versions of this document.

© 2017 STMicroelectronics – All rights reserved