



Chipsmall Limited consists of a professional team with an average of over 10 year of expertise in the distribution of electronic components. Based in Hongkong, we have already established firm and mutual-benefit business relationships with customers from,Europe,America and south Asia,supplying obsolete and hard-to-find components to meet their specific needs.

With the principle of “Quality Parts,Customers Priority,Honest Operation,and Considerate Service”,our business mainly focus on the distribution of electronic components. Line cards we deal with include Microchip,ALPS,ROHM,Xilinx,Pulse,ON,Everlight and Freescale. Main products comprise IC,Modules,Potentiometer,IC Socket,Relay,Connector.Our parts cover such applications as commercial,industrial, and automotives areas.

We are looking forward to setting up business relationship with you and hope to provide you with the best service and solution. Let us make a better world for our industry!



## Contact us

Tel: +86-755-8981 8866 Fax: +86-755-8427 6832

Email & Skype: info@chipsmall.com Web: www.chipsmall.com

Address: A1208, Overseas Decoration Building, #122 Zhenhua RD., Futian, Shenzhen, China



### Features

- Operating voltage: 5 V DC
- Built-in thermal printer
- External barcode scanner
- Memory interface
- LCD display
- Rechargeable battery supply system
- RoHS compliant

### Description

The STEVAL-IPC004V1 demonstration board works in a similar way to a typical POS. It captures item information using a USB-based barcode scanner and, after processing the barcode information, adds it to the transaction record.

To complete the transaction, there is the option of payment using a smartcard/magnetic card interface over GPRS or by entering the cash amount using a keypad.

The internal thermal printer is used to print the sales report and the sales record is recorded in the onboard memory.

The STEVAL-IPC004V1 operates from a 5 V adaptor which is connected to the board through the power jack provided.

The system also comes with a PC-based server application which has various access levels to control STEVAL-IPC004V1 activities such as registration, the loading of item allotment tables in the internal memory, and the obtaining of sales data for future reference. The server keeps sales data in the database for future reference for up to 2 months and it also monitors the STEVAL-IPC004V1 health status and accordingly enables/disables its functioning.



For human interaction, there is a keypad which has 16 keys, allowing a flexible interface.

It is also possible to customize the system to include interfaces such as a smartcard, GPRS, etc., as per customer requirements.

# 1 Schematics

Figure 1. Schematic diagram (1 of 11)

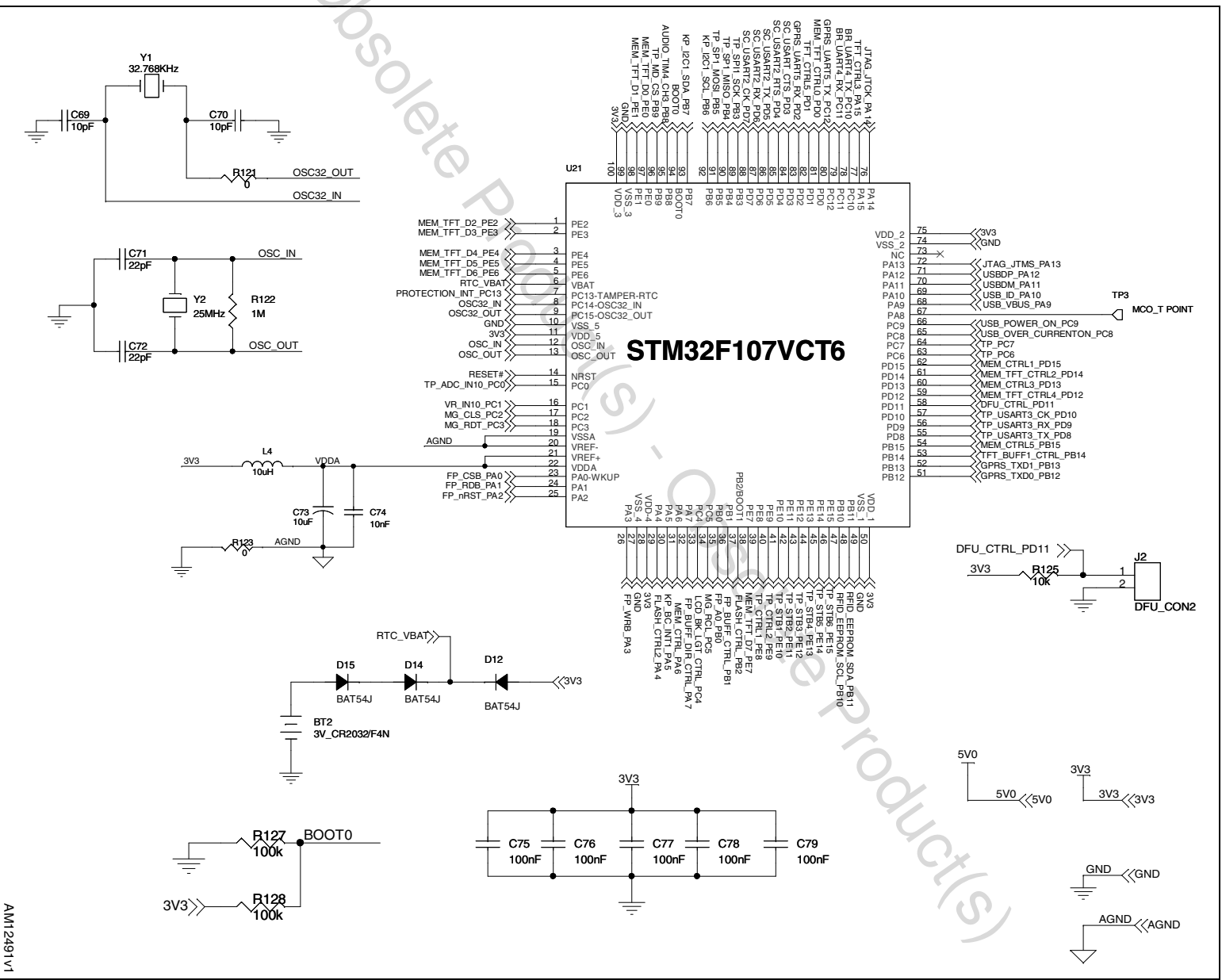

AM12491v1



Figure 2. Schematic diagram (2 of 11)

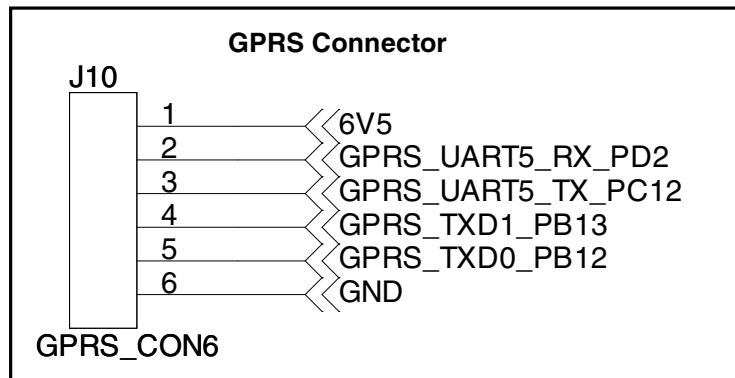
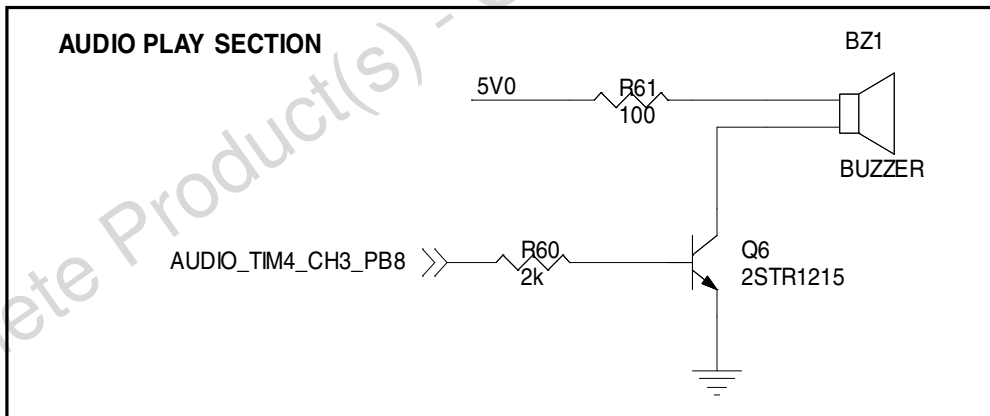
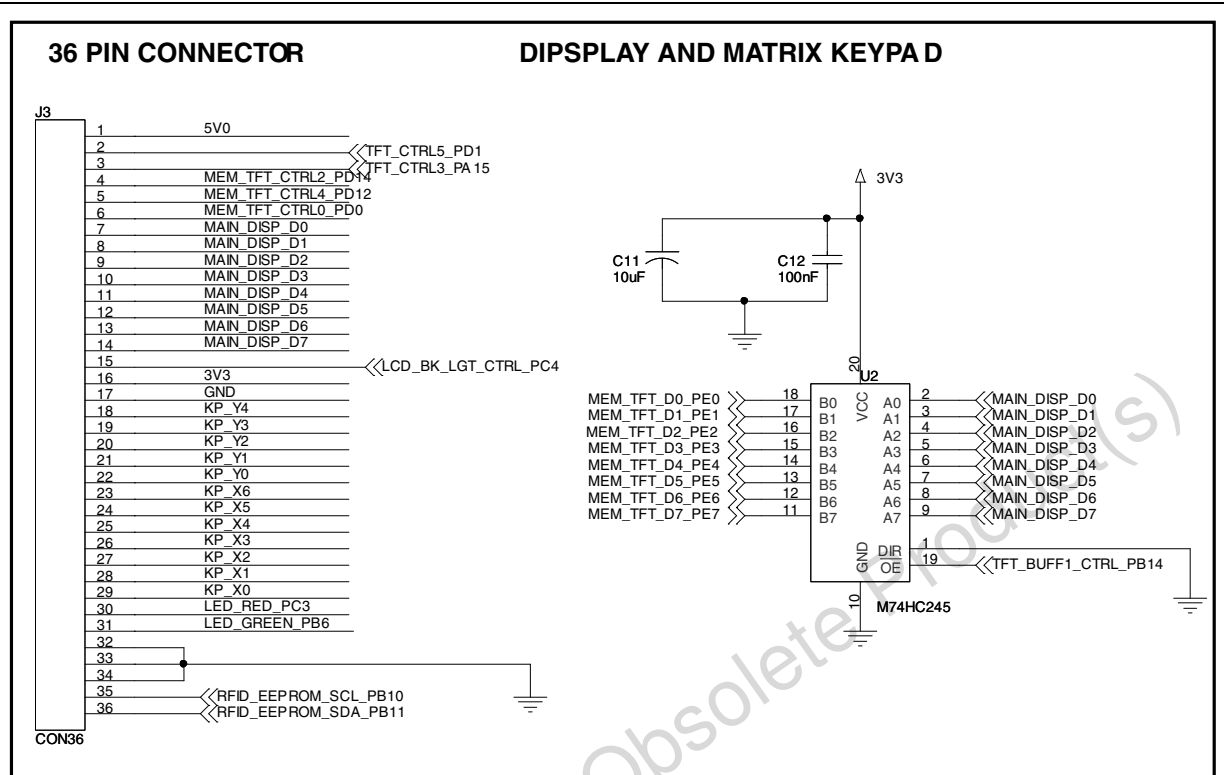

AM12492v1



Figure 4. Schematic diagram (4 of 11)

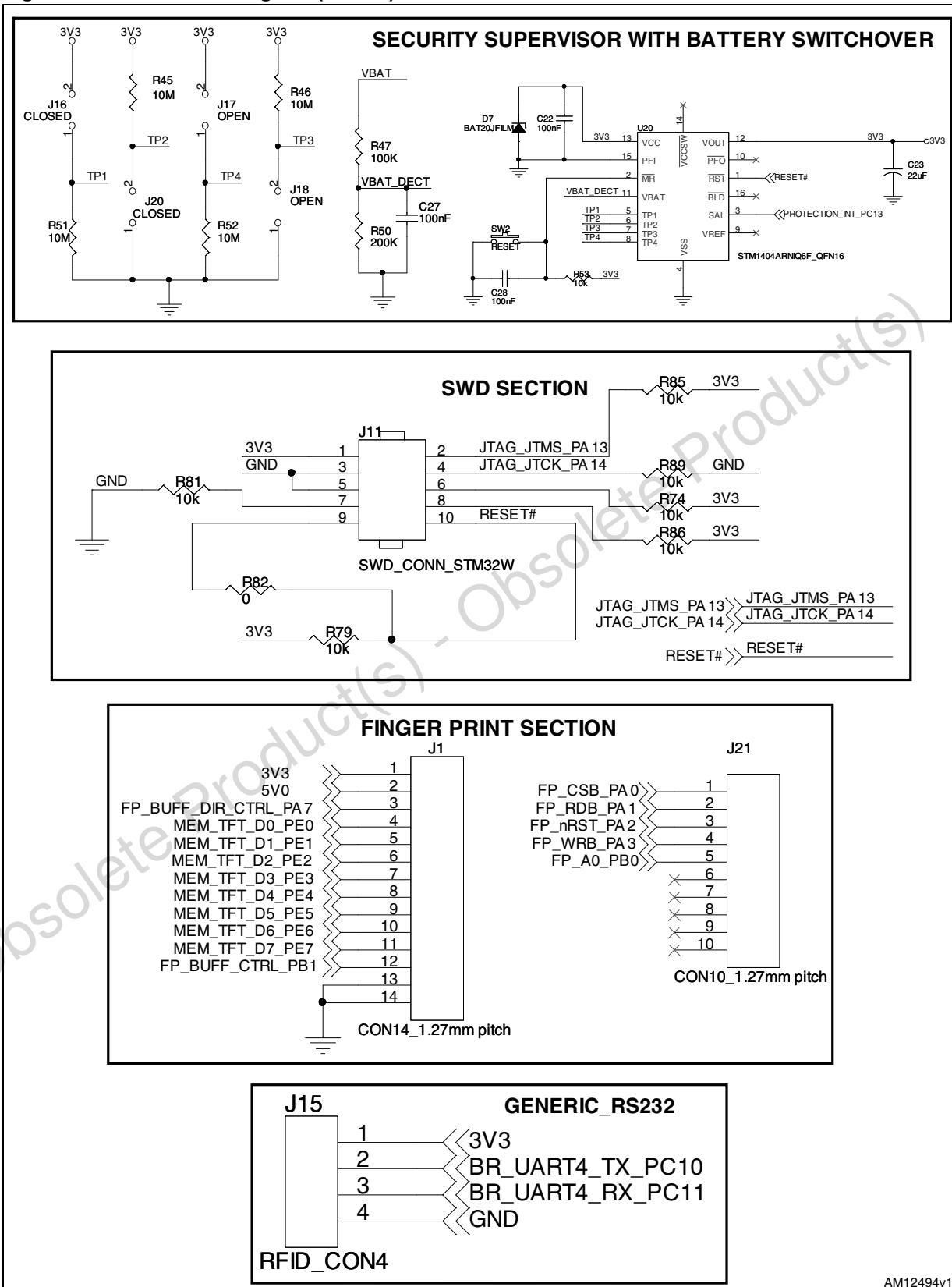

AM12494V1

Figure 5. Schematic diagram (5 of 11)

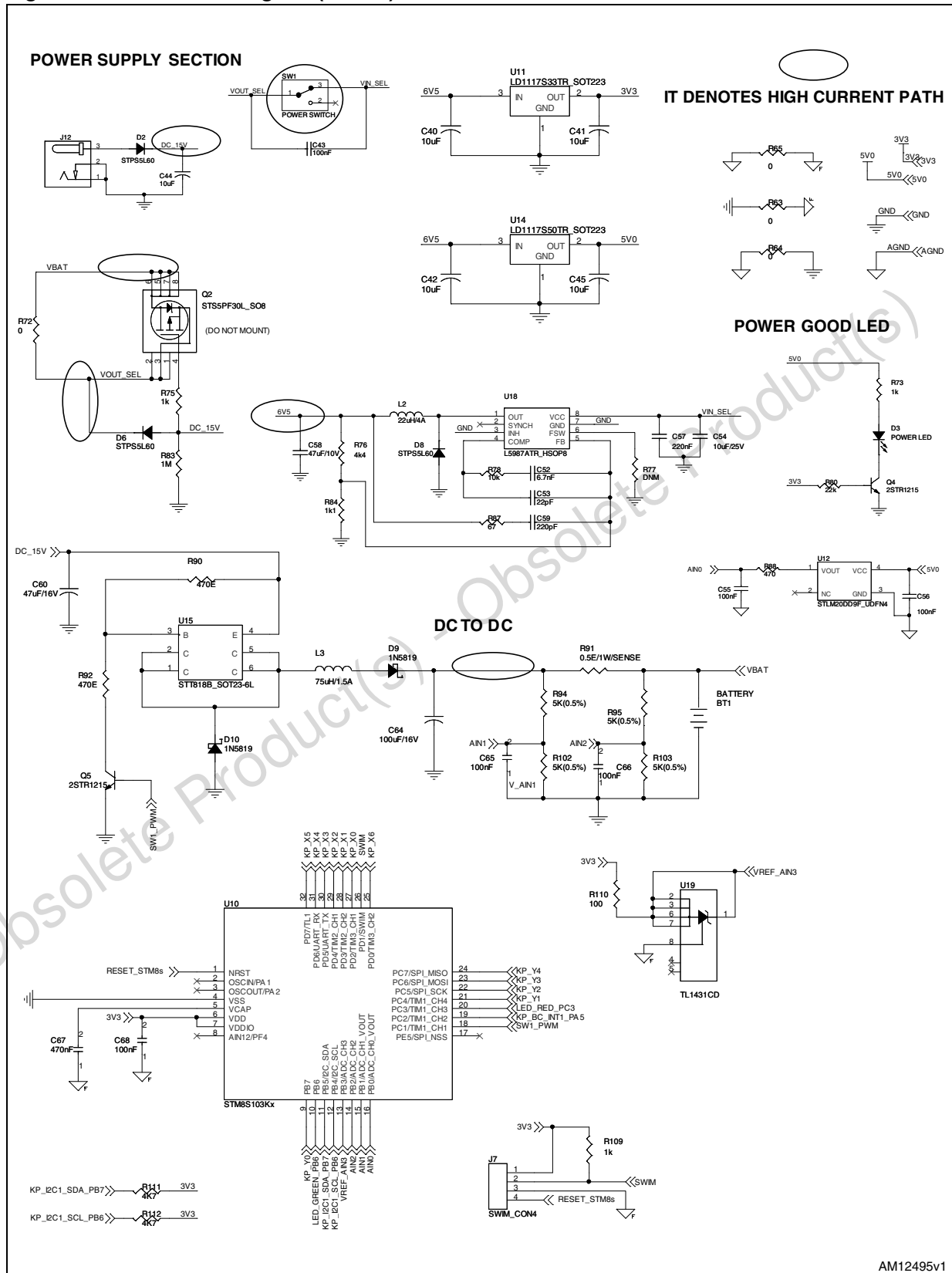
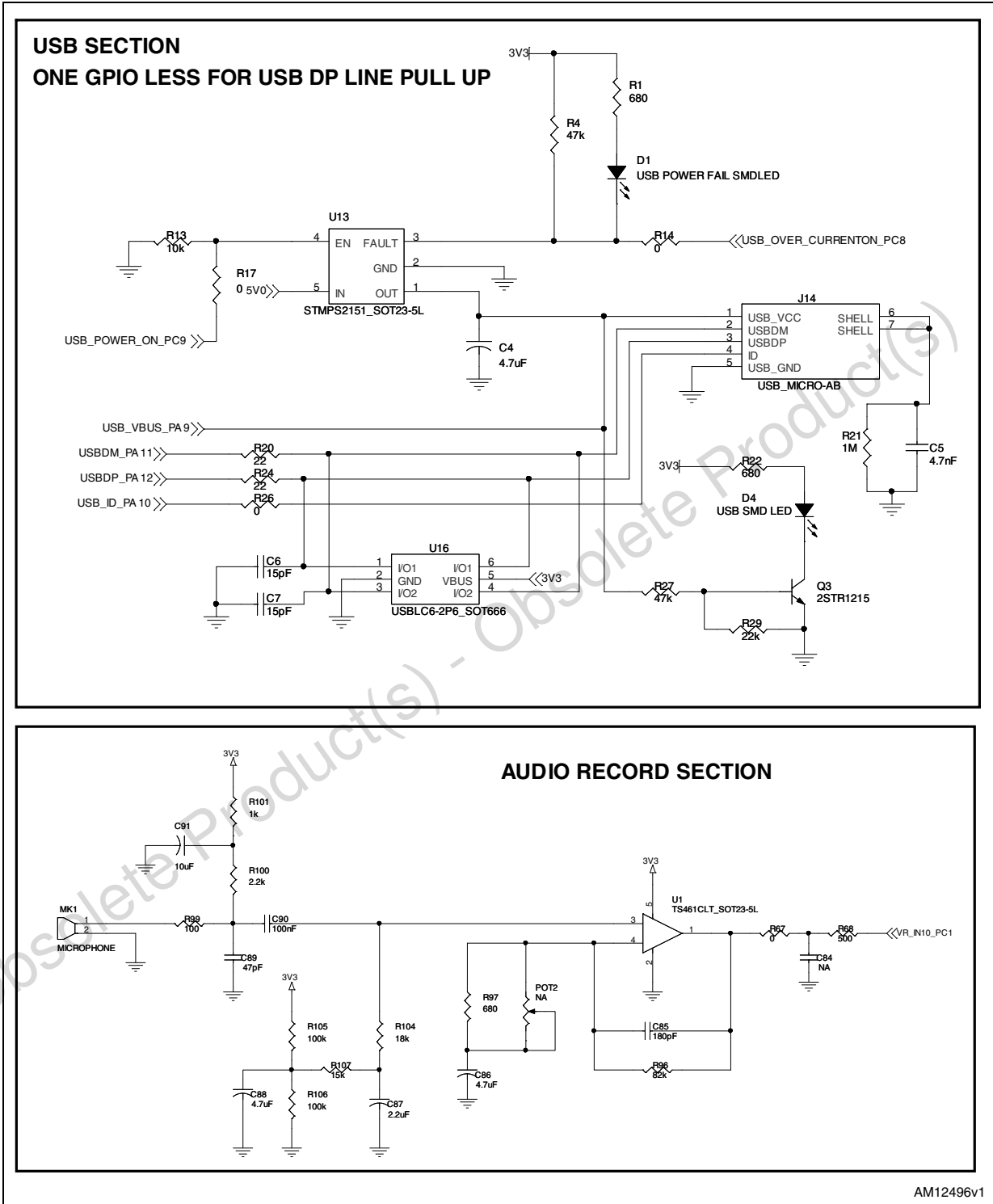

Figure 6. Schematic diagram (6 of 11)



AM12496v1

Figure 7. Schematic diagram (7 of 11)

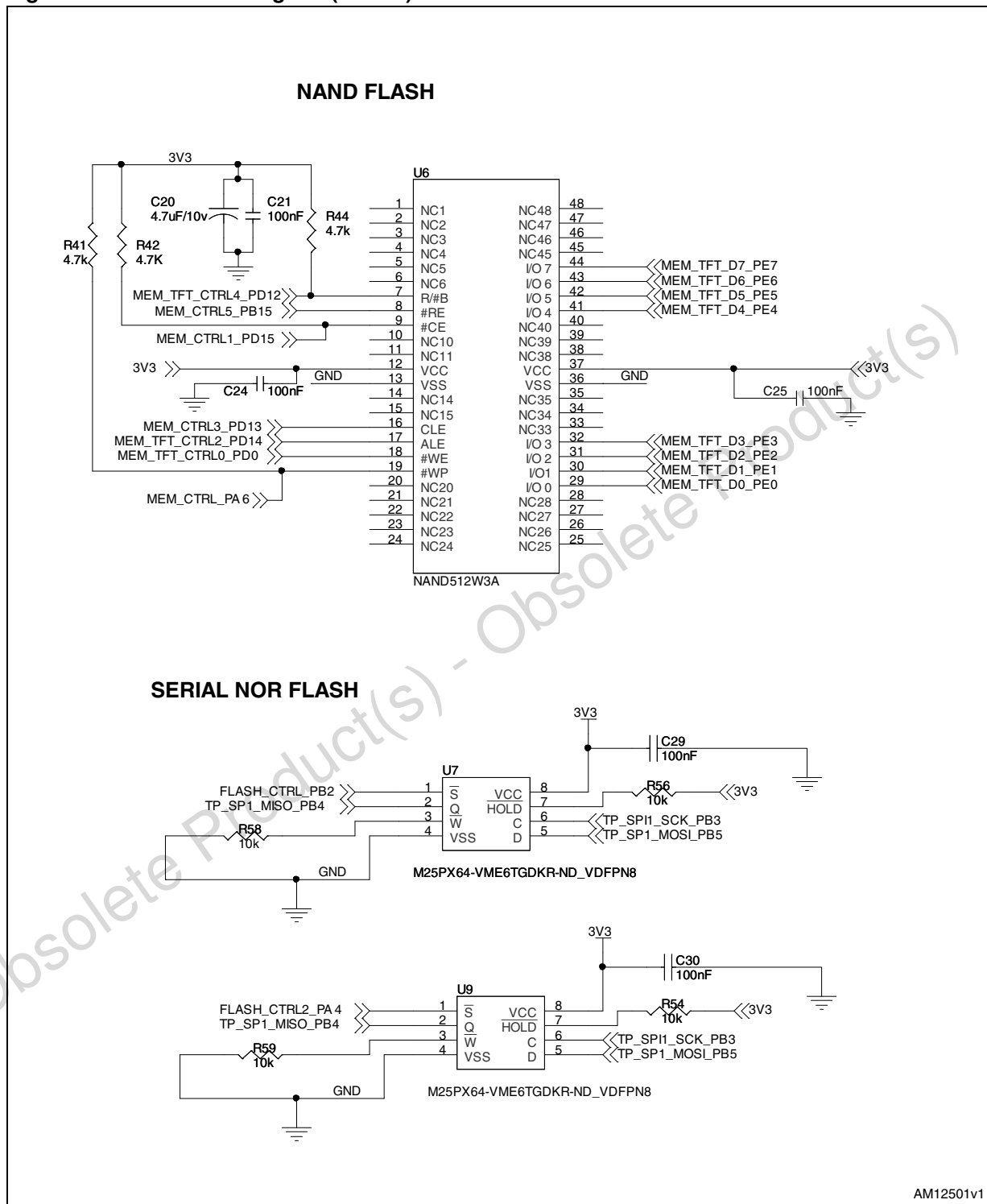

Figure 8. Schematic diagram (8 of 11)

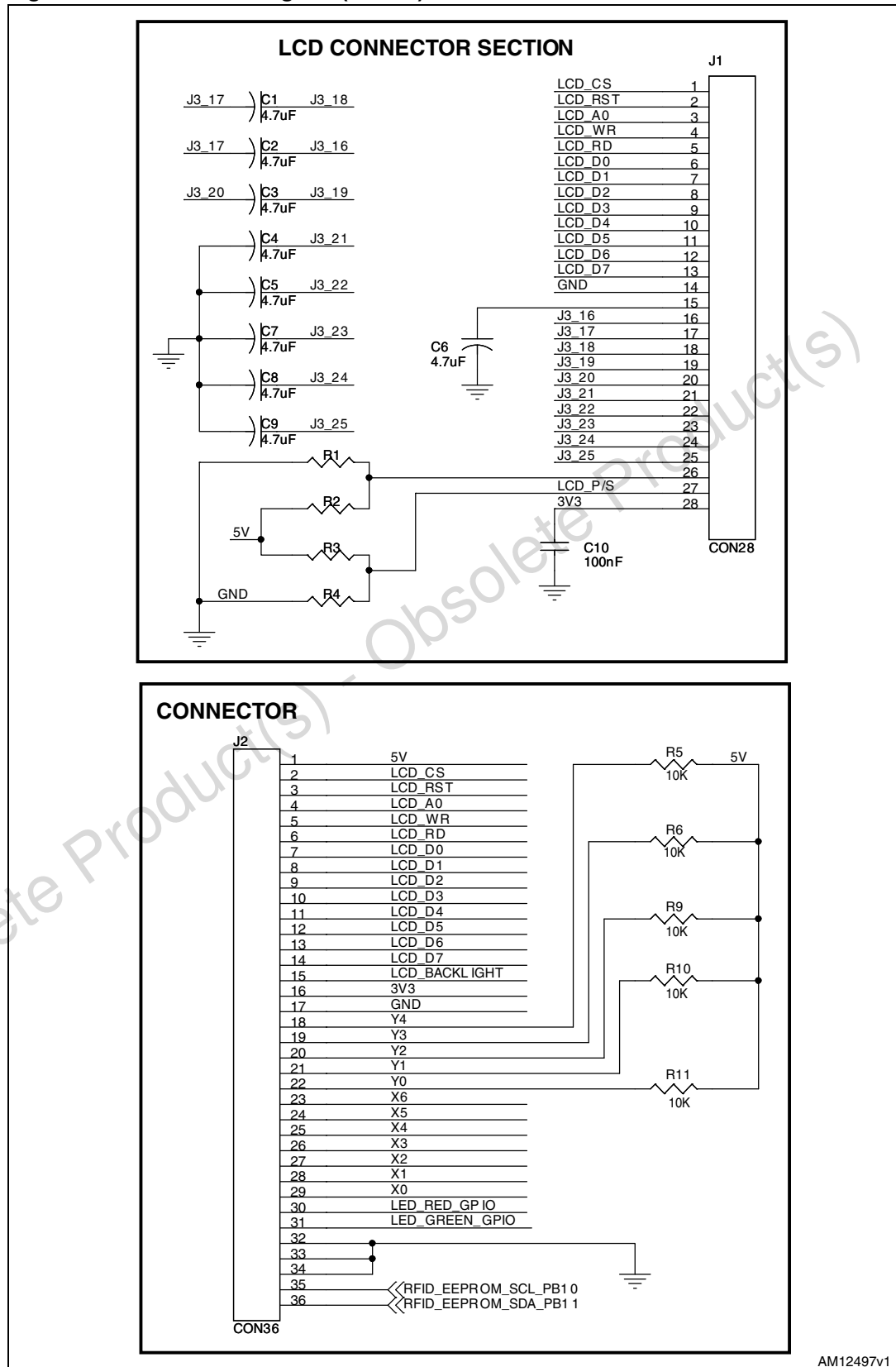

Figure 9. Schematic diagram (9 of 11)

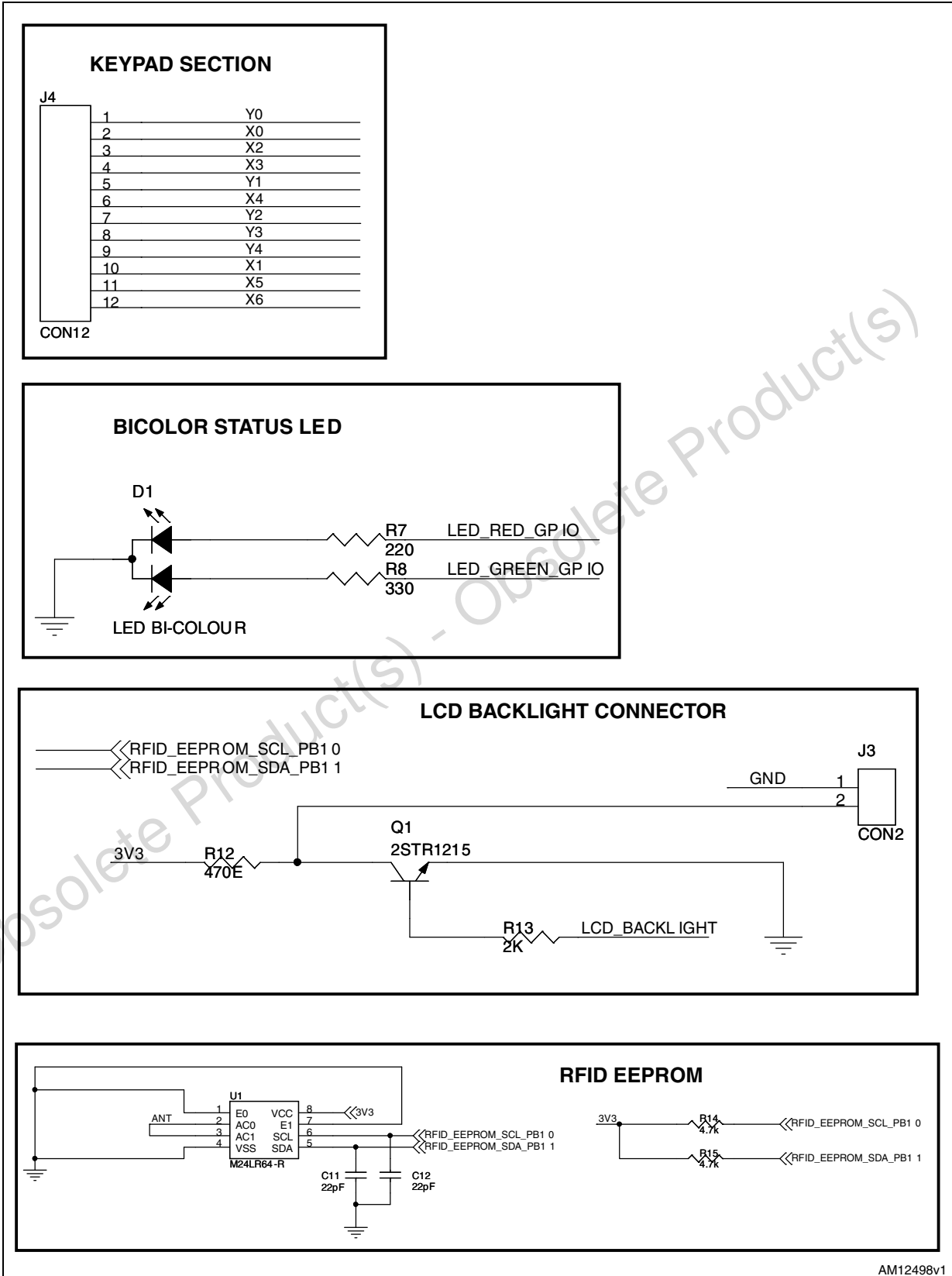
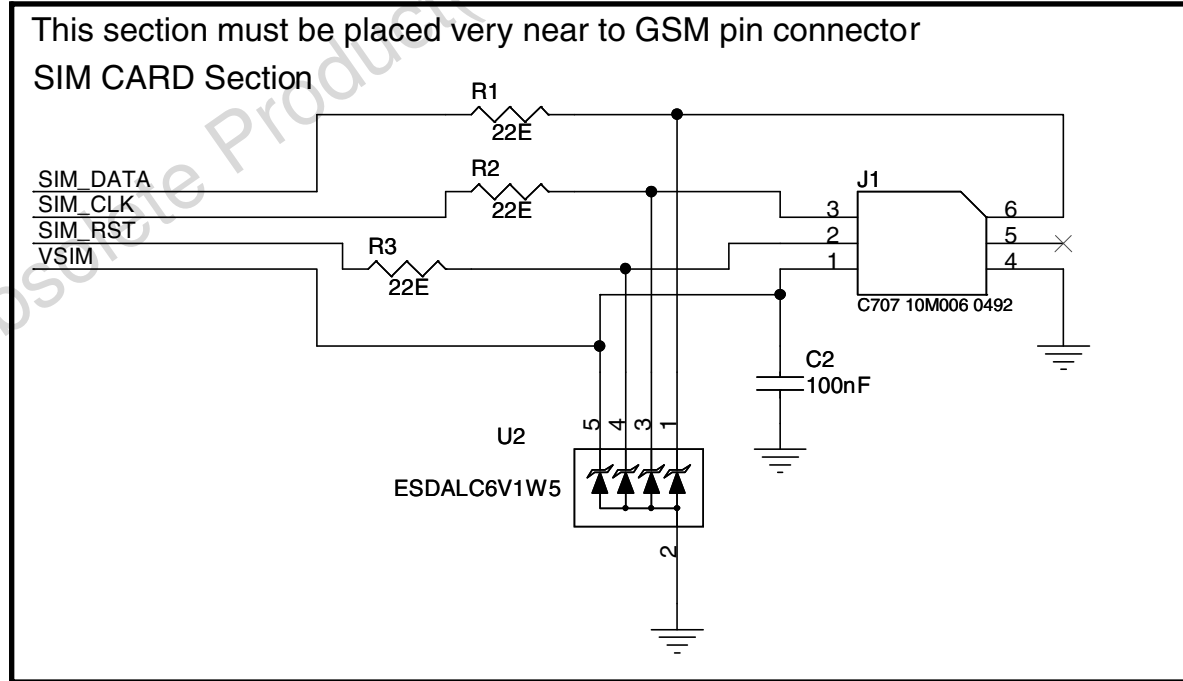
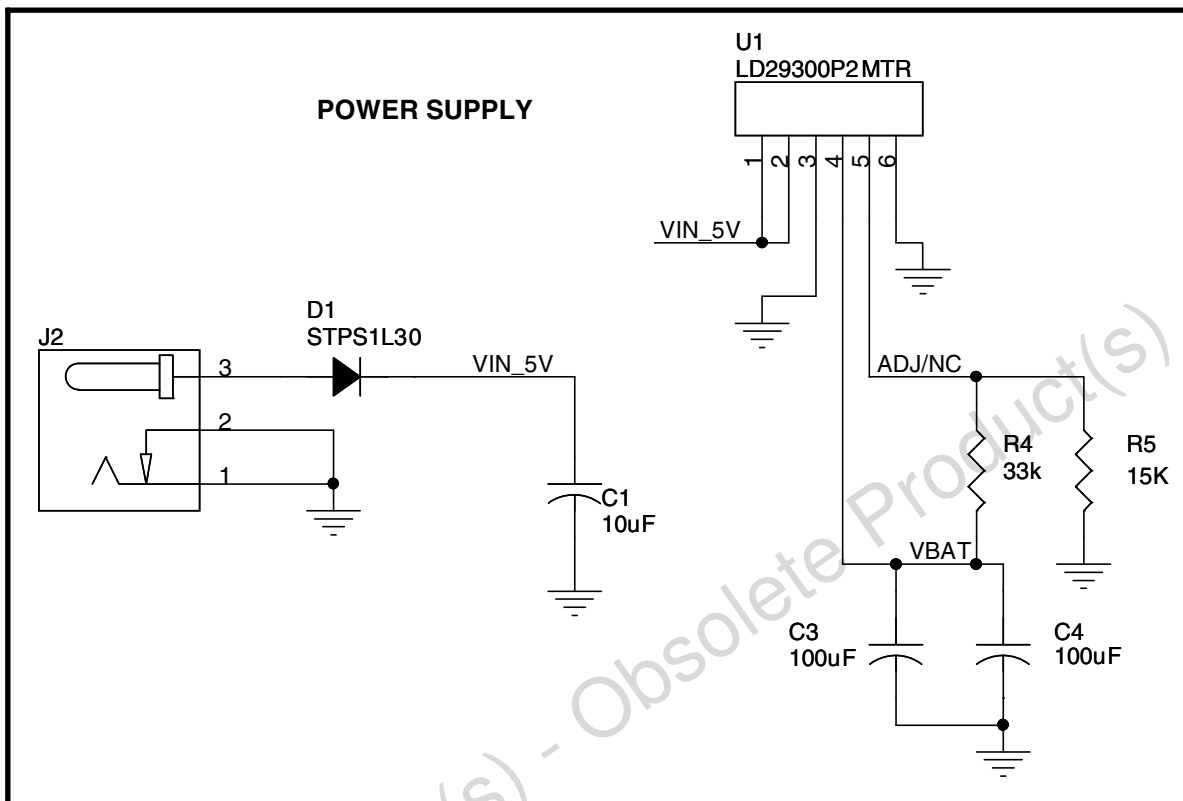
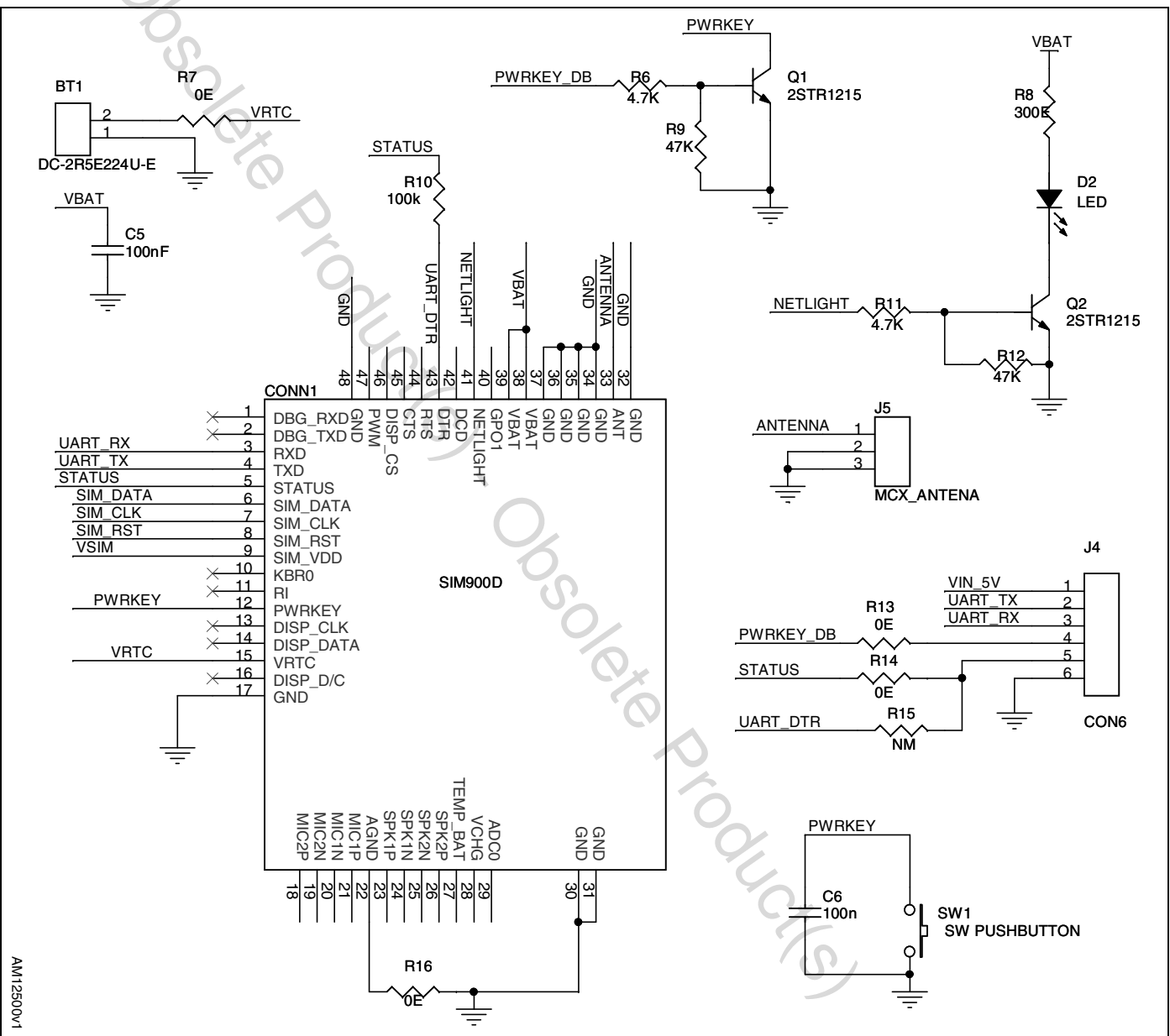

Figure 10. Schematic diagram (10 of 11)



AM12499v1

Figure 11. Schematic diagram (11 of 11)



AM12500V1



## 2 Revision history

Table 1. Document revision history

Date	Revision	Changes
29-Oct-2012	1	Initial release.

Obsolete Product(s) - Obsolete Product(s)

**Please Read Carefully:**

Information in this document is provided solely in connection with ST products. STMicroelectronics NV and its subsidiaries ("ST") reserve the right to make changes, corrections, modifications or improvements, to this document, and the products and services described herein at any time, without notice.

All ST products are sold pursuant to ST's terms and conditions of sale.

Purchasers are solely responsible for the choice, selection and use of the ST products and services described herein, and ST assumes no liability whatsoever relating to the choice, selection or use of the ST products and services described herein.

No license, express or implied, by estoppel or otherwise, to any intellectual property rights is granted under this document. If any part of this document refers to any third party products or services it shall not be deemed a license grant by ST for the use of such third party products or services, or any intellectual property contained therein or considered as a warranty covering the use in any manner whatsoever of such third party products or services or any intellectual property contained therein.

**UNLESS OTHERWISE SET FORTH IN ST'S TERMS AND CONDITIONS OF SALE ST DISCLAIMS ANY EXPRESS OR IMPLIED WARRANTY WITH RESPECT TO THE USE AND/OR SALE OF ST PRODUCTS INCLUDING WITHOUT LIMITATION IMPLIED WARRANTIES OF MERCHANTABILITY, FITNESS FOR A PARTICULAR PURPOSE (AND THEIR EQUIVALENTS UNDER THE LAWS OF ANY JURISDICTION), OR INFRINGEMENT OF ANY PATENT, COPYRIGHT OR OTHER INTELLECTUAL PROPERTY RIGHT.**

**UNLESS EXPRESSLY APPROVED IN WRITING BY TWO AUTHORIZED ST REPRESENTATIVES, ST PRODUCTS ARE NOT RECOMMENDED, AUTHORIZED OR WARRANTED FOR USE IN MILITARY, AIR CRAFT, SPACE, LIFE SAVING, OR LIFE SUSTAINING APPLICATIONS, NOR IN PRODUCTS OR SYSTEMS WHERE FAILURE OR MALFUNCTION MAY RESULT IN PERSONAL INJURY, DEATH, OR SEVERE PROPERTY OR ENVIRONMENTAL DAMAGE. ST PRODUCTS WHICH ARE NOT SPECIFIED AS "AUTOMOTIVE GRADE" MAY ONLY BE USED IN AUTOMOTIVE APPLICATIONS AT USER'S OWN RISK.**

Resale of ST products with provisions different from the statements and/or technical features set forth in this document shall immediately void any warranty granted by ST for the ST product or service described herein and shall not create or extend in any manner whatsoever, any liability of ST.

ST and the ST logo are trademarks or registered trademarks of ST in various countries.

Information in this document supersedes and replaces all information previously supplied.

The ST logo is a registered trademark of STMicroelectronics. All other names are the property of their respective owners.

© 2012 STMicroelectronics - All rights reserved

STMicroelectronics group of companies

Australia - Belgium - Brazil - Canada - China - Czech Republic - Finland - France - Germany - Hong Kong - India - Israel - Italy - Japan - Malaysia - Malta - Morocco - Philippines - Singapore - Spain - Sweden - Switzerland - United Kingdom - United States of America

[www.st.com](http://www.st.com)