



Chipsmall Limited consists of a professional team with an average of over 10 year of expertise in the distribution of electronic components. Based in Hongkong, we have already established firm and mutual-benefit business relationships with customers from,Europe,America and south Asia,supplying obsolete and hard-to-find components to meet their specific needs.

With the principle of “Quality Parts,Customers Priority,Honest Operation,and Considerate Service”,our business mainly focus on the distribution of electronic components. Line cards we deal with include Microchip,ALPS,ROHM,Xilinx,Pulse,ON,Everlight and Freescale. Main products comprise IC,Modules,Potentiometer,IC Socket,Relay,Connector.Our parts cover such applications as commercial,industrial, and automotives areas.

We are looking forward to setting up business relationship with you and hope to provide you with the best service and solution. Let us make a better world for our industry!



## Contact us

Tel: +86-755-8981 8866 Fax: +86-755-8427 6832

Email & Skype: info@chipsmall.com Web: www.chipsmall.com

Address: A1208, Overseas Decoration Building, #122 Zhenhua RD., Futian, Shenzhen, China



## STEVAL-ISA031V1: 40 W SMPS with HV MOSFET and L6565 for three-phase industrial applications

### Introduction

This document introduces a solution for industrial power supplies fed by a three-phase mains. It employs a high voltage (1500 V breakdown voltage) power MOSFET to optimize the operation of a quasi-resonant flyback converter based on the primary controller L6565. The demonstration board has been designed and developed specifically for low power applications. The board features two outputs, 24 V and 5 V, and is capable of delivering more than 40 W of output power. The 5 V output is obtained by means of an integrated DC-DC converter based on the L5970AD 1.5 A switch step-down switching regulator, connected to the 24 V output. The demonstration board is available through order code STEVAL-ISA031V1.

Figure 1. STEVAL-ISA031V1 demonstration board - top side

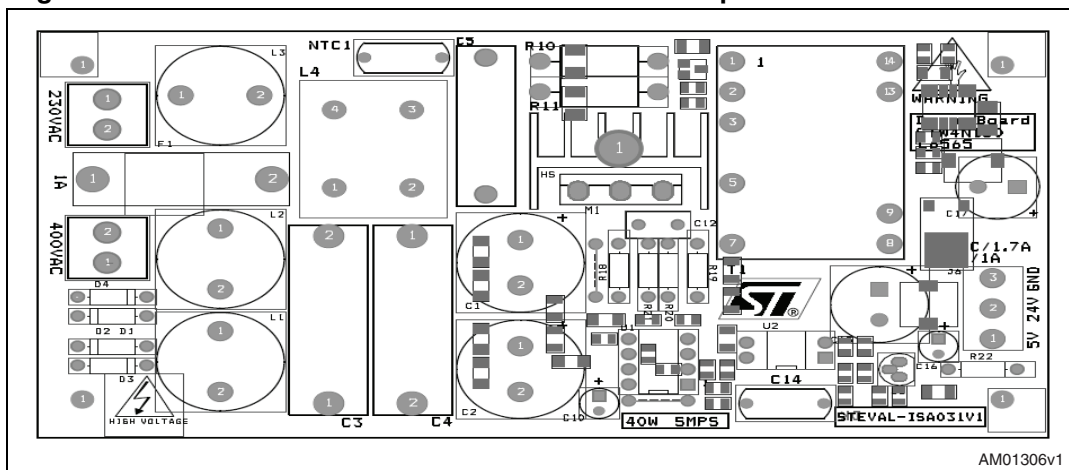
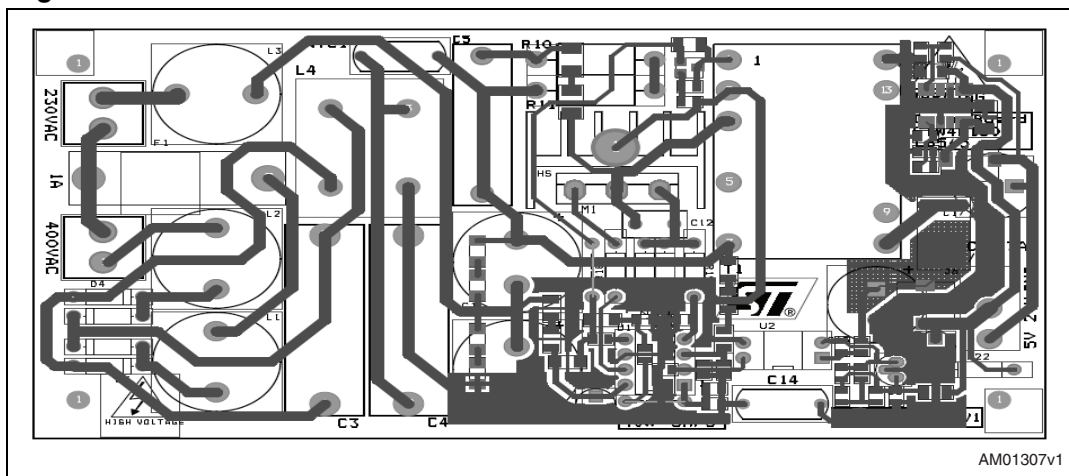

Figure 2. STEVAL-ISA031V1 demonstration board - bottom side



# Contents

<b>1</b>	<b>Demonstration board description</b> .....	<b>3</b>
	1.1 Bill of materials .....	5
<b>2</b>	<b>Revision history</b> .....	<b>8</b>

# 1 Demonstration board description

The STEVAL-ISA031V1 demonstration board is based on a quasi resonant flyback converter and employs the STW4N150 power MOSFET as the primary switch. The STW4N150 is a 5  $\Omega$  1500 V power MOSFET designed with STMicroelectronics' proprietary high voltage "Mesh Overlay" technology, which gives the switch very low  $R_{DS(on)}$  per area, low gate charge and high switching performance. The STW4N150 device is available in the TO-220, TO-247 and TO-220FH packages.

The main specifications of the demonstration board are provided in table below.

**Table 1. STEVAL-ISA031V1 main specifications**

Parameter	Value
Input voltage range	185 to 460 Vac
Input frequency range	50/60 Hz
Output 1	24 V @ 1.7 A
Output 2	5 V @ 1 A
Output power	40 W
Safety	EN60950
EMI	EN55014

The input section features two connectors: CON1 for 400 Vac input voltage and CON2 for 230 Vac input voltage.

The output voltages are available on CON3, with a shared ground between the two outputs.

The converter is controlled by the L6565, a primary controller for quasi resonant ZVS (zero voltage switching) flyback converters. The IC controls the power capability variations with the mains voltage by means of line voltage feed-forward. In addition to the very low startup and quiescent currents, the device manages light load conditions with optimized consumption thanks to a special function which automatically lowers the operating frequency while maintaining operation as close to ZVS as possible. The IC also includes a disable function, an on-chip filter on current sense, an error amplifier with a precise reference voltage for primary regulation and effective two-level overcurrent protection.

The transformer reflected voltage is set to 400 V, providing sufficient margin for the leakage inductance voltage spike, and a small RCD clamper circuit is used to limit excess voltage on the drain of the MOSFET.

During normal operation, the IC is powered by the auxiliary winding of the transformer via diode D7. A spike killer circuit for auxiliary voltage fluctuations is provided but not connected (Q11, C13, R13). The primary current is measured using external sensing resistors (R20, R21) for current mode operation.

Output voltage regulation is performed via a secondary feedback on the 24 V output. The feedback network consists of a programmable voltage reference, TL431, driving an optocoupler which ensures the required insulation between the primary and secondary sections. The optotransistor drives the feedback pin (COMP) which controls the operation of the IC.

LC filters have been added on both outputs to reduce high frequency ripple, with moderate output capacitor values.

The flyback transformer is a layer-type based on an ETD29 core and N67 ferrite, manufactured by Tronic, with insulation meeting EN60950 safety standards.

Figure 3. Circuit schematic

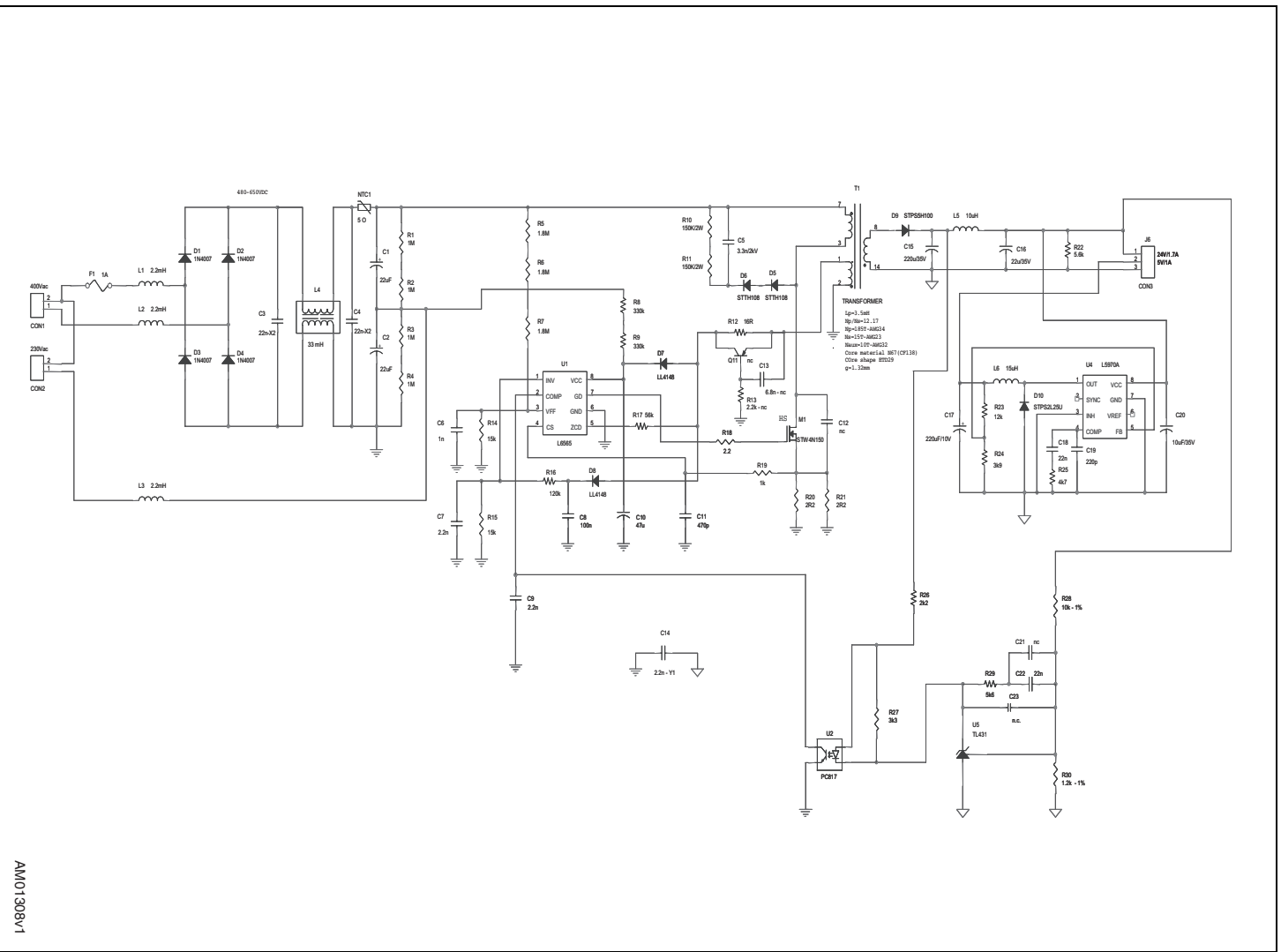

AM01308v1

The 5 V output is obtained from the 24 V output by means of an integrated power IC, the L5970AD.

The L5970AD is a step-down monolithic power switching regulator with a switch current limit of 1.5 A, capable of delivering more than 1 A of DC current to the load depending on application conditions. The output voltage can be adjusted down to 1.235 V by a voltage divider. The device uses an internal P-channel DMOS transistor, with a typical  $R_{DS(on)}$  of 200 m $\Omega$  as a switching element to avoid the need for a bootstrap capacitor and to guarantee high efficiency. An internal oscillator sets the switching frequency at 500 kHz to minimize the size of external components. The power IC features several protection functions, such as pulse-by-pulse current limiting, with the internal frequency modulation aimed at effective constant current short-circuit protection, feedback disconnection and thermal shutdown. Finally, the device can be synchronized using a dedicated pin, and also inhibited for reduced standby power consumption and time sequence operations.

The schematic of the board is shown in [Figure 3](#). The complete power supply is built on a double-sided 35  $\mu$ m PCB in FR-4, sized 130 x 66 mm.

The bill of materials is given in table below.

## 1.1 Bill of materials

**Table 2. STEVAL-ISA031V1 bill of materials**

Reference	Value	Description
C1	22 $\mu$ F - 450 V	Elect. capacitor – 85 °C
C2	22 $\mu$ F - 450 V	Elect. capacitor – 85 °C
C3	22 nF - 660 Vac	Polip. capacitor X2
C4	22 nF - 660 Vac	Polip. capacitor X2
C5	4.7 nF - 2 kV	Polip. capacitor FKP1 - WIMA
C6	1 nF	Elect. capacitor
C7	2.2 nF	Ceramic capacitor
C8	100 nF	Ceramic capacitor
C9	2.2 nF	Ceramic capacitor
C10	47 $\mu$ F	Ceramic capacitor
C11	470 pF	Ceramic capacitor
C12	n.m.	Ceramic capacitor
C13	6.8 nF (n.m.)	Ceramic capacitor
C14	2.2 nF	Polip. capacitor X1 Y1
C15	220 $\mu$ F – 35 V	Elect. capacitor
C16	22 $\mu$ F – 35 V	Elect. capacitor
C17	220 $\mu$ F – 10 V	Elect. capacitor
C18	22 nF	Ceramic capacitor
C19	220 pF	Ceramic capacitor

**Table 2. STEVAL-ISA031V1 bill of materials (continued)**

Reference	Value	Description
C20	10 µF- 35 V	Elect capacitor
C21	n.m.	
C22	22 nF	Ceramic capacitor
C23	n.m.	
D1, D2, D3, D4	1N4007	Rectifier 1000 V 1 A
D5	STTH108	STMicroelectronics turboswitch diode 1 A - 800 V
D6	STTH108	STMicroelectronics turboswitch diode 1 A - 800 V
D7	LL4148	SOD-80 general purpose rectifier 75 V 200 mA
D8	LL4148	SOD-80 general purpose rectifier 75 V 200 mA
D9	STPS5H100	Schottky rectifier 5 A - 100 V
D10	STPS2L25U	Schottky rectifier 2 A - 25 V
L1, L2, L3	2.2 mH	Inductor - TDK SL1720-222KR60
L4	33 mH	Common mode choke - TDK 333Y0R0
L5	10 µH	Inductor - TDK SLF7045T - 100M1R3
L6	15 µH	Inductor - TDK SLF7045T - 150M1R1
NTC1	5 Ω	NTC inrush current suppressor - EPCOS 0544
F1	1 A	Fuse
R1	1 mΩ	Resistor
R2	1 mΩ	Resistor
R3	1 mΩ	Resistor
R4	1 mΩ	Resistor
R5	1.8 mΩ	Resistor
R6	1.8 mΩ	Resistor
R7	1.8 mΩ	Resistor
R8	330 kΩ	Resistor
R9	330 kΩ	Resistor
R10	150 kΩ	Resistor, 2 W
R11	150 kΩ	Resistor, 2 W
R12	22 Ω	Resistor, SMD-1206
R13	2.2 kΩ (n.m)	Resistor
R14	15 kΩ	Resistor, SMD-0805
R15	15 kΩ	Resistor, SMD-0805
R16	120 kΩ	Resistor
R17	56 kΩ	Resistor
R18	2.2 Ω	Resistor

Table 2. STEVAL-ISA031V1 bill of materials (continued)

Reference	Value	Description
R19	1 k $\Omega$	Resistor
R20	2.2 $\Omega$	Resistor
R21	2.2 $\Omega$	Resistor
R22	4.7 k $\Omega$	Resistor, 0.25 W TRH
R23	12 k $\Omega$	Resistor
R24	3.9 k $\Omega$	Resistor
R25	4.7 k $\Omega$	Resistor
R26	2.2 k $\Omega$	Resistor
R27	3.3 k $\Omega$	Resistor
R28	10 k $\Omega$	Resistor, 0.25 W 1%
R29	5.6 k $\Omega$	Resistor
R30	1.2 k $\Omega$	Resistor, 0.25 W 1%
T1	0603261	Switch mode transformer - Tronic
U1	L6565	STMicroelectronics quasi resonant controller
U2	PC817	Optocoupler - Sharp
U4	L5970AD	STMicroelectronics - 1.5 A switch step-down switching regulator
U5	TL431	STMicroelectronics programmable shunt voltage reference 1%
M1	STW4N150	STMicroelectronics MOSFET 1500 V - 5 $\Omega$ - 4 A
Q11	BC547 (n.m.)	Small signal PNP transistor

## 2 Revision history

**Table 3. Document revision history**

Date	Revision	Changes
24-Sep-2009	1	Initial release.

**Please Read Carefully:**

Information in this document is provided solely in connection with ST products. STMicroelectronics NV and its subsidiaries ("ST") reserve the right to make changes, corrections, modifications or improvements, to this document, and the products and services described herein at any time, without notice.

All ST products are sold pursuant to ST's terms and conditions of sale.

Purchasers are solely responsible for the choice, selection and use of the ST products and services described herein, and ST assumes no liability whatsoever relating to the choice, selection or use of the ST products and services described herein.

No license, express or implied, by estoppel or otherwise, to any intellectual property rights is granted under this document. If any part of this document refers to any third party products or services it shall not be deemed a license grant by ST for the use of such third party products or services, or any intellectual property contained therein or considered as a warranty covering the use in any manner whatsoever of such third party products or services or any intellectual property contained therein.

**UNLESS OTHERWISE SET FORTH IN ST'S TERMS AND CONDITIONS OF SALE ST DISCLAIMS ANY EXPRESS OR IMPLIED WARRANTY WITH RESPECT TO THE USE AND/OR SALE OF ST PRODUCTS INCLUDING WITHOUT LIMITATION IMPLIED WARRANTIES OF MERCHANTABILITY, FITNESS FOR A PARTICULAR PURPOSE (AND THEIR EQUIVALENTS UNDER THE LAWS OF ANY JURISDICTION), OR INFRINGEMENT OF ANY PATENT, COPYRIGHT OR OTHER INTELLECTUAL PROPERTY RIGHT.**

**UNLESS EXPRESSLY APPROVED IN WRITING BY AN AUTHORIZED ST REPRESENTATIVE, ST PRODUCTS ARE NOT RECOMMENDED, AUTHORIZED OR WARRANTED FOR USE IN MILITARY, AIR CRAFT, SPACE, LIFE SAVING, OR LIFE SUSTAINING APPLICATIONS, NOR IN PRODUCTS OR SYSTEMS WHERE FAILURE OR MALFUNCTION MAY RESULT IN PERSONAL INJURY, DEATH, OR SEVERE PROPERTY OR ENVIRONMENTAL DAMAGE. ST PRODUCTS WHICH ARE NOT SPECIFIED AS "AUTOMOTIVE GRADE" MAY ONLY BE USED IN AUTOMOTIVE APPLICATIONS AT USER'S OWN RISK.**

Resale of ST products with provisions different from the statements and/or technical features set forth in this document shall immediately void any warranty granted by ST for the ST product or service described herein and shall not create or extend in any manner whatsoever, any liability of ST.

ST and the ST logo are trademarks or registered trademarks of ST in various countries.

Information in this document supersedes and replaces all information previously supplied.

The ST logo is a registered trademark of STMicroelectronics. All other names are the property of their respective owners.

© 2009 STMicroelectronics - All rights reserved

STMicroelectronics group of companies

Australia - Belgium - Brazil - Canada - China - Czech Republic - Finland - France - Germany - Hong Kong - India - Israel - Italy - Japan - Malaysia - Malta - Morocco - Philippines - Singapore - Spain - Sweden - Switzerland - United Kingdom - United States of America

[www.st.com](http://www.st.com)

