



Chipsmall Limited consists of a professional team with an average of over 10 year of expertise in the distribution of electronic components. Based in Hongkong, we have already established firm and mutual-benefit business relationships with customers from,Europe,America and south Asia,supplying obsolete and hard-to-find components to meet their specific needs.

With the principle of "Quality Parts,Customers Priority,Honest Operation,and Considerate Service",our business mainly focus on the distribution of electronic components. Line cards we deal with include Microchip,ALPS,ROHM,Xilinx,Pulse,ON,Everlight and Freescale. Main products comprise IC,Modules,Potentiometer,IC Socket,Relay,Connector.Our parts cover such applications as commercial,industrial, and automotives areas.

We are looking forward to setting up business relationship with you and hope to provide you with the best service and solution. Let us make a better world for our industry!



Contact us

Tel: +86-755-8981 8866 Fax: +86-755-8427 6832

Email & Skype: info@chipsmall.com Web: www.chipsmall.com

Address: A1208, Overseas Decoration Building, #122 Zhenhua RD., Futian, Shenzhen, China



Evaluation board for the LD39020 high PSRR, 200 mA LDO

Data brief

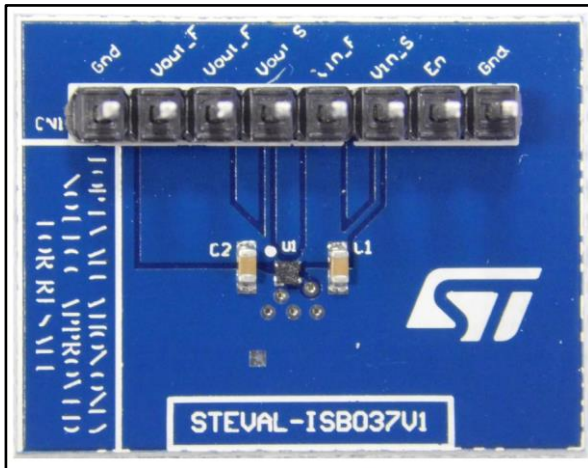
**Features**

- Output current: 200 mA
- Logic controlled electronic shutdown
- High PSRR
 - 80 dB @ 1 kHz
 - 50 db @ 100 kHz
- Quiescent current:
 - 20 μ A typ at no load
 - 0.03 μ A typ in off mode
- 1.8 V \pm 0.5% output voltage
- Other voltage options available on request
- DFN4-1 x 1 package (0.8 x 0.8 available on request)
- RoHS compliant

Description

The STEVAL-ISB037V1 board features the LD39020 high performance linear voltage regulator, configured to convert a DC input voltage from 2.4 V to 5.5 V into a precise and stable 1.8 V output voltage.

Only two small ceramic capacitors are needed to implement the linear regulator solution.

The very low dropout LD39020 voltage regulator features high PSRR and low quiescent current in a tiny DFN4 package with a footprint of only (1 x 1) mm².

It is designed for low-power battery operated equipment such as smartphones, tablets and wearable devices.

1 Schematic diagram

Figure 1: STEVAL-ISB037V1 circuit schematic

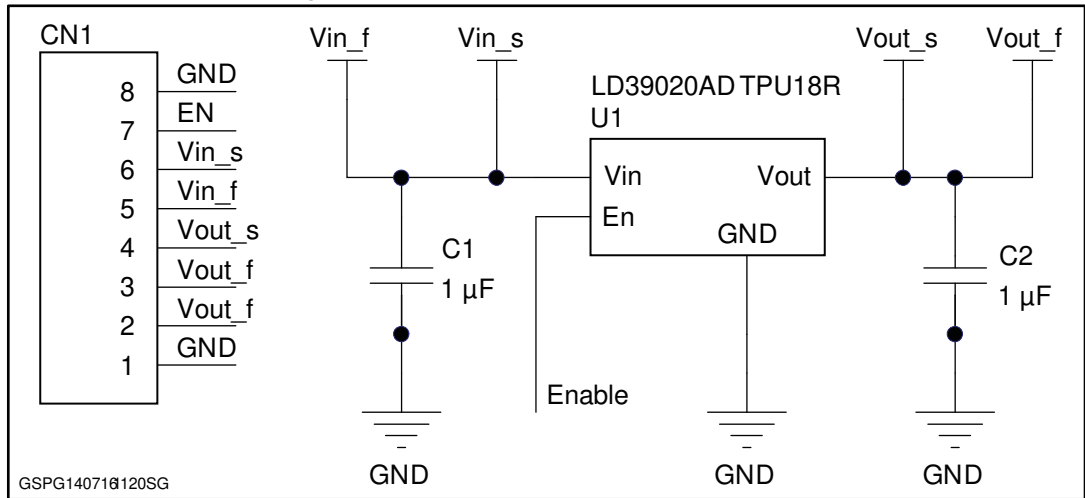

2 Revision history

Table 1: Document revision history

Date	Version	Changes
06-Sep-2016	1	Initial release.

IMPORTANT NOTICE – PLEASE READ CAREFULLY

STMicroelectronics NV and its subsidiaries ("ST") reserve the right to make changes, corrections, enhancements, modifications, and improvements to ST products and/or to this document at any time without notice. Purchasers should obtain the latest relevant information on ST products before placing orders. ST products are sold pursuant to ST's terms and conditions of sale in place at the time of order acknowledgement.

Purchasers are solely responsible for the choice, selection, and use of ST products and ST assumes no liability for application assistance or the design of Purchasers' products.

No license, express or implied, to any intellectual property right is granted by ST herein.

Resale of ST products with provisions different from the information set forth herein shall void any warranty granted by ST for such product.

ST and the ST logo are trademarks of ST. All other product or service names are the property of their respective owners.

Information in this document supersedes and replaces information previously supplied in any prior versions of this document.

© 2016 STMicroelectronics – All rights reserved