



Chipsmall Limited consists of a professional team with an average of over 10 year of expertise in the distribution of electronic components. Based in Hongkong, we have already established firm and mutual-benefit business relationships with customers from,Europe,America and south Asia,supplying obsolete and hard-to-find components to meet their specific needs.

With the principle of "Quality Parts,Customers Priority,Honest Operation,and Considerate Service",our business mainly focus on the distribution of electronic components. Line cards we deal with include Microchip,ALPS,ROHM,Xilinx,Pulse,ON,Everlight and Freescale. Main products comprise IC,Modules,Potentiometer,IC Socket,Relay,Connector.Our parts cover such applications as commercial,industrial, and automotives areas.

We are looking forward to setting up business relationship with you and hope to provide you with the best service and solution. Let us make a better world for our industry!



Contact us

Tel: +86-755-8981 8866 Fax: +86-755-8427 6832

Email & Skype: info@chipsmall.com Web: www.chipsmall.com

Address: A1208, Overseas Decoration Building, #122 Zhenhua RD., Futian, Shenzhen, China



7.5 W non-isolated constant current LED driver based on VIPer0P

Data brief

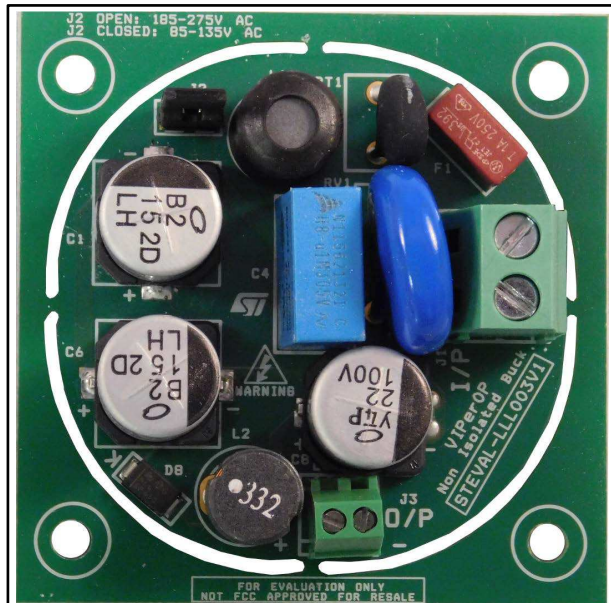

Description

The STEVAL-LLL003V1 evaluation board is a constant current LED driver, based on non-isolated buck topology using VIPer0P.

The board delivers $130\text{ mA} \pm 2.5\%$ at an output load of 15 – 21 white LEDs.

The buck topology ensures a minimum number of components as well as higher efficiency when operating at high output voltage (60 V and above).

The application core is the new VIPer0P offline high voltage converter which smartly integrates an 800 V avalanche rugged power MOSFET with current-mode control.

Thanks to the embedded E/A (EAGND) floating GND, the direct current regulation can be applied to the buck converter, improving the LED current accuracy.

Features

- Non-isolated buck topology
- Two input voltage ranges:
 - US range: 85-135 V_{AC} (jumper J2 - closed, voltage doubler)
 - EU range: 175-285 V_{AC} (jumper J2 - open, bridge rectifier)
- 130 mA $\pm 2.5\%$ output constant current (15-21 white LEDs connected)
- 60 kHz fixed frequency operation
- $\cong 89\%$ efficiency at maximum load
- Protections:
 - open/no-load circuit protection
 - short/overload circuit protection
 - thermal shutdown
- Soft start for improved system reliability
- Meets IEC55022 Class B conducted EMI even with reduced EMI filter, thanks to the frequency jittering feature
- Meets IEC61000-4-2(ESD), IEC61000-4-4 (Burst) and IEC61000-4-5 (Surge)
- RoHS compliant

Schematic diagram

Figure 1: STEVAL-LLL003V1 circuit schematic

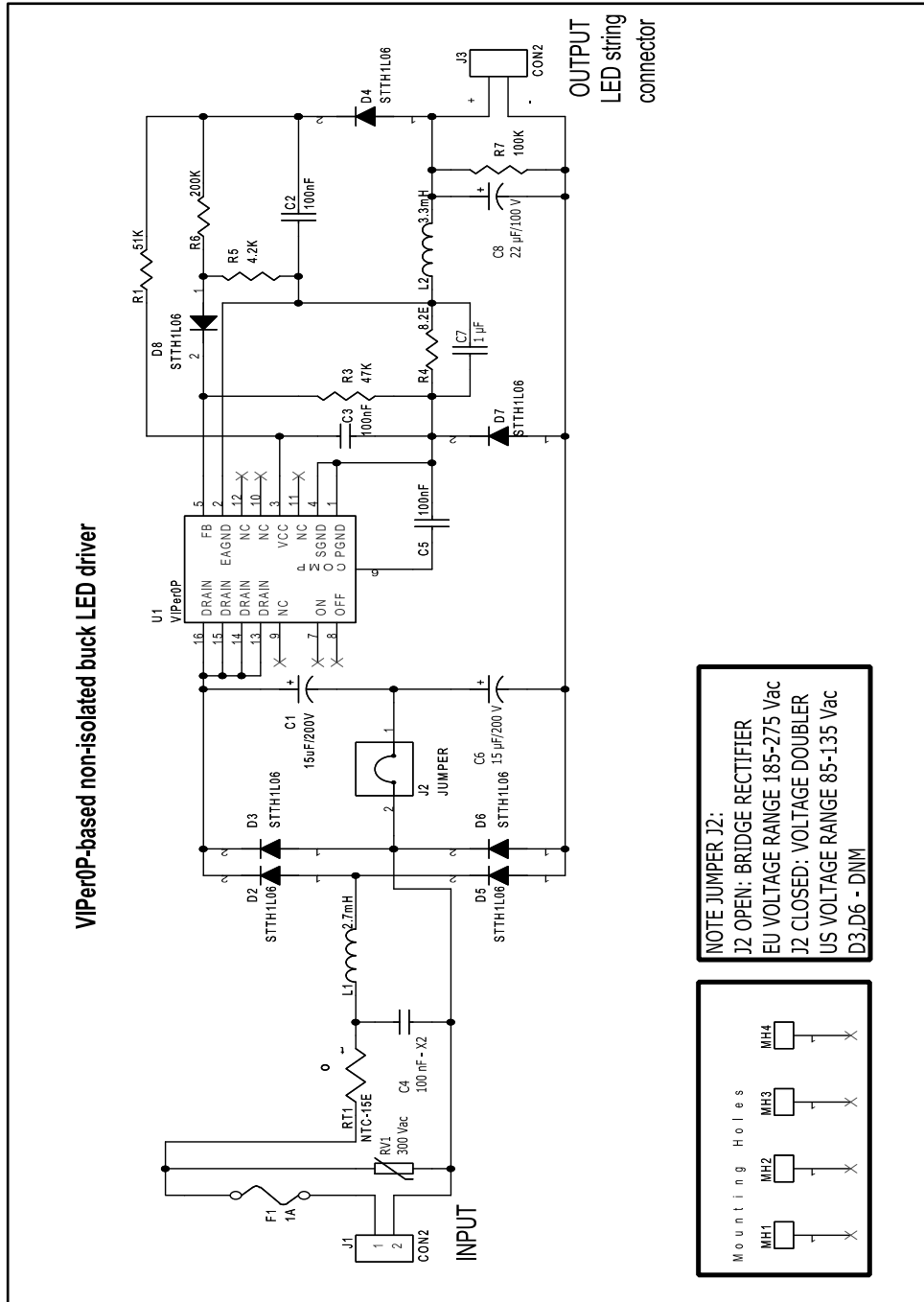

Revision history

Table 1: Document revision history

Date	Version	Changes
04-Sep-2017	1	First release.

IMPORTANT NOTICE – PLEASE READ CAREFULLY

STMicroelectronics NV and its subsidiaries ("ST") reserve the right to make changes, corrections, enhancements, modifications, and improvements to ST products and/or to this document at any time without notice. Purchasers should obtain the latest relevant information on ST products before placing orders. ST products are sold pursuant to ST's terms and conditions of sale in place at the time of order acknowledgement.

Purchasers are solely responsible for the choice, selection, and use of ST products and ST assumes no liability for application assistance or the design of Purchasers' products.

No license, express or implied, to any intellectual property right is granted by ST herein.

Resale of ST products with provisions different from the information set forth herein shall void any warranty granted by ST for such product.

ST and the ST logo are trademarks of ST. All other product or service names are the property of their respective owners.

Information in this document supersedes and replaces information previously supplied in any prior versions of this document.

© 2017 STMicroelectronics – All rights reserved