



Chipsmall Limited consists of a professional team with an average of over 10 year of expertise in the distribution of electronic components. Based in Hongkong, we have already established firm and mutual-benefit business relationships with customers from,Europe,America and south Asia,supplying obsolete and hard-to-find components to meet their specific needs.

With the principle of “Quality Parts,Customers Priority,Honest Operation,and Considerate Service”,our business mainly focus on the distribution of electronic components. Line cards we deal with include Microchip,ALPS,ROHM,Xilinx,Pulse,ON,Everlight and Freescale. Main products comprise IC,Modules,Potentiometer,IC Socket,Relay,Connector.Our parts cover such applications as commercial,industrial, and automotives areas.

We are looking forward to setting up business relationship with you and hope to provide you with the best service and solution. Let us make a better world for our industry!



## Contact us

Tel: +86-755-8981 8866 Fax: +86-755-8427 6832

Email & Skype: info@chipsmall.com Web: www.chipsmall.com

Address: A1208, Overseas Decoration Building, #122 Zhenhua RD., Futian, Shenzhen, China



## L3GD20 and LSM303DLHC 9-axis module for a standard DIL24 socket

Data brief

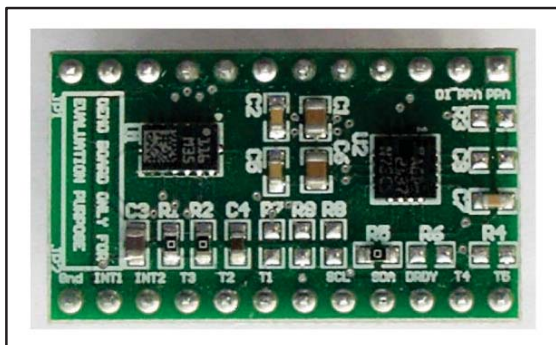

### Features

- Complete L3GD20 and LSM303DLHC pinout for a standard DIL 24 socket
- Fully compatible with the STEVAL-MKI109V2 and STEVAL-MKI109V3 motherboards
- RoHS compliant

### Description

The STEVAL-MKI108V2 is an adapter board designed to facilitate the evaluation of L3GD20 and LSM303DLHC MEMS devices. The board offers an effective solution for fast system prototyping and device evaluation directly within the user's own application.

The STEVAL-MKI108V2 can be plugged into a standard DIL 24 socket. The adapter provides the complete L3GD20 and LSM303DLHC pinout and comes ready-to-use with the required decoupling capacitors on the V<sub>DD</sub> power supply line.

This adapter is supported by the STEVAL-MKI109V2 and STEVAL-MKI109V3 motherboards which include a high performance 32-bit microcontroller functioning as a bridge between the sensor and a PC, on which it is possible to use the downloadable graphical user interface (Unico GUI), or dedicated software routines for customized applications.

# 1 Schematic diagram

Figure 1 : STEVAL-MK1108V2 circuit schematic

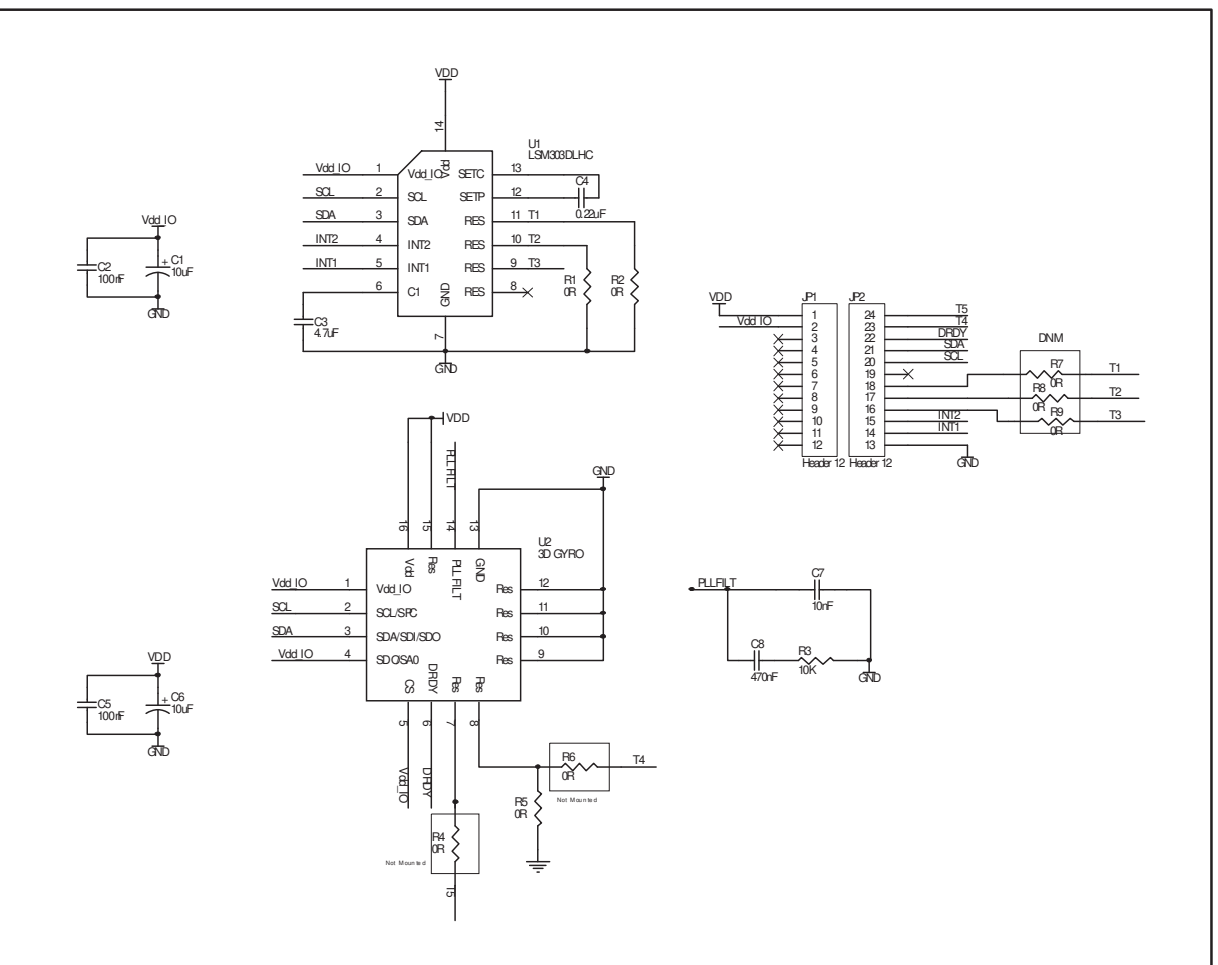

## 2 Revision history

Table 1: Document revision history

Date	Revision	Changes
03-Nov-2011	1	Initial release.
25-Oct-2013	2	Updated features and description to include information on the STEVAL-MKI109V2 motherboard and related software.
05-Sep-2016	3	Updated features and description adding STEVAL-MKI109V3 motherboard compatibility

**IMPORTANT NOTICE – PLEASE READ CAREFULLY**

STMicroelectronics NV and its subsidiaries ("ST") reserve the right to make changes, corrections, enhancements, modifications, and improvements to ST products and/or to this document at any time without notice. Purchasers should obtain the latest relevant information on ST products before placing orders. ST products are sold pursuant to ST's terms and conditions of sale in place at the time of order acknowledgement.

Purchasers are solely responsible for the choice, selection, and use of ST products and ST assumes no liability for application assistance or the design of Purchasers' products.

No license, express or implied, to any intellectual property right is granted by ST herein.

Resale of ST products with provisions different from the information set forth herein shall void any warranty granted by ST for such product.

ST and the ST logo are trademarks of ST. All other product or service names are the property of their respective owners.

Information in this document supersedes and replaces information previously supplied in any prior versions of this document.

© 2016 STMicroelectronics – All rights reserved