



Chipsmall Limited consists of a professional team with an average of over 10 year of expertise in the distribution of electronic components. Based in Hongkong, we have already established firm and mutual-benefit business relationships with customers from,Europe,America and south Asia,supplying obsolete and hard-to-find components to meet their specific needs.

With the principle of “Quality Parts,Customers Priority,Honest Operation,and Considerate Service”,our business mainly focus on the distribution of electronic components. Line cards we deal with include Microchip,ALPS,ROHM,Xilinx,Pulse,ON,Everlight and Freescale. Main products comprise IC,Modules,Potentiometer,IC Socket,Relay,Connector.Our parts cover such applications as commercial,industrial, and automotives areas.

We are looking forward to setting up business relationship with you and hope to provide you with the best service and solution. Let us make a better world for our industry!



## Contact us

Tel: +86-755-8981 8866 Fax: +86-755-8427 6832

Email & Skype: info@chipsmall.com Web: www.chipsmall.com

Address: A1208, Overseas Decoration Building, #122 Zhenhua RD., Futian, Shenzhen, China



### STEVAL-MKI111V1 - water level detection based on the LPS001WP MEMS pressure sensor

#### Introduction

The STEVAL-MKI111V1 is a low cost demonstration board for the home appliance market. It is designed to efficiently replace the mechanical or electromechanical pressure sensor in domestic and industrial washing machines (or similar appliances), where the measurement of the water level is performed by a pressure measurement.

The system features a 20-pin, 8-bit STM8S103F2 microcontroller running at 16 MHz (RC user-trimmable internal RC clock), featuring 4 kB of Flash memory, a 10-bit A-D converter, 8/16-bit timers, communication interfaces and 640-byte EEPROM.

The power supply circuitry is based on the LD1117S33, an adjustable and fixed low drop positive voltage regulator. The power supply provides an output voltage of 3.3 V from an input voltage in the range 5 V - 12 V DC.

The STEVAL-MKI111V1 is designed to measure temperature and pressure inside a container (i.e. the drum of a washing machine, or similar), by means of a rubber tube connected between the container and the demonstration board itself. The core device is the LPS001WP MEMS pressure sensor, a 300-1100 mbar absolute digital output barometer. The MEMS communicates with the MCU through an I<sup>2</sup>C bus.

The demonstration board also features an LED user interface and a connector for an STMicroelectronics™ debugging tool.

**Figure 1. STEVAL-MKI111V1**

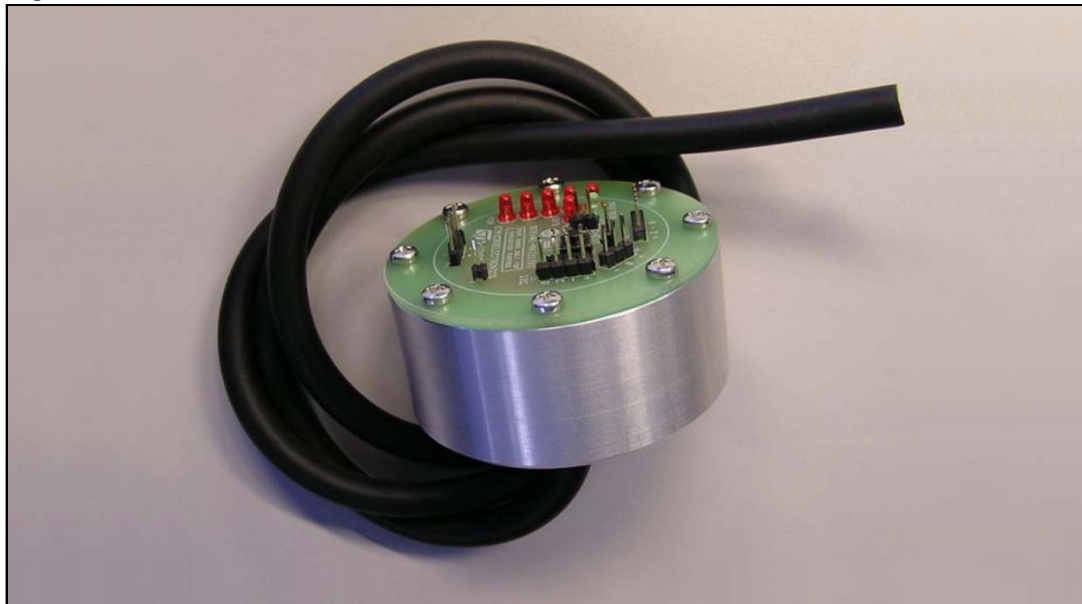

# Contents

- 1 System introduction ..... 5**
  - 1.1 Main features ..... 5
  - 1.2 Target applications ..... 5
  - 1.3 Safety and operating instructions ..... 5
    - 1.3.1 General terms ..... 5
    - 1.3.2 Intended use ..... 5
    - 1.3.3 Installation ..... 6
    - 1.3.4 Electrical connection ..... 6
    - 1.3.5 Board operation ..... 6
- 2 Board description ..... 7**
  - 2.1 Block diagram ..... 7
  - 2.2 Schematic diagram ..... 8
  - 2.3 How the system works ..... 9
    - 2.3.1 Startup ..... 9
    - 2.3.2 Setting the pressure reference (zero, 0 mbar) ..... 10
    - 2.3.3 Output signals ..... 10
    - 2.3.4 LED bar ..... 10
- 3 Connectors, test pins and jumpers ..... 11**
- 4 Bill of material ..... 14**
- 5 The STEVAL-MKI111V1 layout ..... 15**
- 6 Software customization and real-time debug ..... 20**
  - 6.1 Pressure signal ..... 20
  - 6.2 Temperature signal ..... 20
- 7 Ordering information ..... 21**
- 8 References ..... 21**
- 9 Revision history ..... 22**

## List of tables

Table 1.	Connector pinout description . . . . .	12
Table 2.	Test points description . . . . .	12
Table 3.	MCU programming connector (J4) . . . . .	12
Table 4.	PWM modulation connector (J3) . . . . .	12
Table 5.	I <sup>2</sup> C interface connector (J5) . . . . .	13
Table 6.	Bill of material . . . . .	14
Table 7.	Document revision history . . . . .	22

## List of figures

Figure 1.	STEVAL-MKI111V1 .....	1
Figure 2.	STEVAL-MKI111V1 block diagram. ....	7
Figure 3.	STEVAL-MKI111V1 circuit schematic - part 1 .....	8
Figure 4.	STEVAL-MKI111V1 circuit schematic - part 2 .....	9
Figure 5.	How to connect the STEVAL-MKI111V1 .....	11
Figure 6.	STEVAL-MKI111V1 silk-screen (top) .....	15
Figure 7.	STEVAL-MKI111V1 silk-screen (bottom) .....	16
Figure 8.	STEVAL-MKI111V1 top layer .....	17
Figure 9.	STEVAL-MKI111V1 top view .....	18
Figure 10.	STEVAL-MKI111V1 bottom view .....	19

# 1 System introduction

## 1.1 Main features

The main features of the STEVAL-MKI111V1 demonstration board are:

- Input voltage range: 5-12 V DC or direct 3.3 V DC power supply
- LPS001WP MEMS pressure sensor, 300-1100 mbar absolute digital output barometer
- 20-pin, 8-bit STM8S103F2 MCU as main controller
- Output signal interfaces available:
  - I<sup>2</sup>C interface
  - PWM modulation (43-38 Hz)
- Onboard or external MEMS control (by selector)
- “Zero” button to reset the pressure offset
- RUN LED, OFS LED, and 5-step indicator bar
- Standard in-circuit programming connector (SWIM, single wire interface module)
- RoHS compliant.

## 1.2 Target applications

As a water level detection demonstration board, the STEVAL-MKI111V1 is mainly targeted at the home appliance market for applications including:

- Domestic or industrial washing machines
- General purpose water level systems
- Respiratory equipment.

## 1.3 Safety and operating instructions

### 1.3.1 General terms

---

**Warning:** This demonstration board must be used in a suitable laboratory environment only, by qualified personnel who are familiar with the installation, use, and maintenance of electrical systems.

---

### 1.3.2 Intended use

The STEVAL-MKI111V1 demonstration board is designed for demonstration purposes only, and must not be used in domestic or industrial installations. The technical data, as well as the information concerning the power supply and working conditions, must be taken from the documentation included in the kit and strictly observed.

### 1.3.3 Installation

The installation of the STEVAL-MKI111V1 is described in this document.

The components must be protected against excessive strain. In particular, no components should be bent, or isolating distances altered during transportation, handling or use. No contact must be made with electronic components and contacts.

The STEVAL-MKI111V1 contains electrostatically sensitive components, which may be damaged if used improperly. To avoid risk of injury, ensure that electrical components are not mechanically damaged.

### 1.3.4 Electrical connection

Applicable accident prevention rules must be followed when working from the mains power supply. The electrical installation must be completed in accordance with the appropriate requirements (e.g. cross-section areas of conductors, fusing and PE connections).

### 1.3.5 Board operation

A system architecture which supplies power to the demonstration board must be equipped with additional control and protective devices, in accordance with the applicable safety requirements (e.g. compliance of equipment and accident prevention rules).

## 2 Board description

### 2.1 Block diagram

The water level detection demonstration board can be divided into a few simple blocks.

**Figure 2. STEVAL-MKI111V1 block diagram**

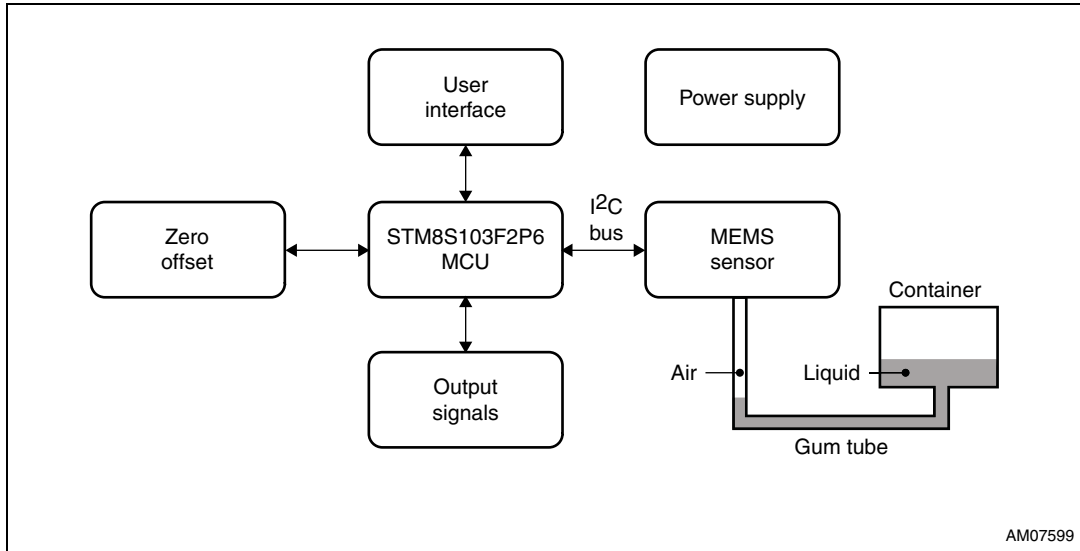

- **Power supply**

The power supply is designed using a low drop positive voltage regulator with fixed output voltage set at 3.3 V DC. The input voltage is in the range 5-12 V DC. The power supply is protected against reverse polarity.

- **MEMS sensor**

The demonstration board is physically connected to a container through a rubber tube. The liquid inside the container goes through the rubber tube, pushing the remaining air against the MEMS sensor. The higher the amount of liquid inside the container, the higher the amount of pressure the MEMS sensor reads.

The MEMS sensor is also equipped with a temperature sensor. The measure of temperature can be used to compensate the pressure drift due to temperature variations.

*Note: To work properly, the MEMS sensor must be mounted higher than the container.*

- **User interface**

The demonstration board features an LED user interface. It roughly shows the pressure (and depression) read by the MEMS sensor.

The user interface is completed with a debugging connector. It serves to precisely read the measurements of pressure and temperature in real-time by means of any standard ST debugging tool with SWIM interface.

- **Output signals**

The pressure and temperature measurements can be accessed either through an I<sup>2</sup>C interface, or by PWM modulation. The signals can be sent to an external MCU through the I<sup>2</sup>C interface. Alternatively, the pressure signal is sent out in the form of a 43-38 Hz



PWM modulation, in order to simulate the functionality of an electromechanical pressure sensor. 43 Hz means 0 mbar, while at 38 Hz the pressure is 30 mbar.

- Zero offset**  
 The zero offset is a way to set a pressure (and temperature) reference before filling the container with the liquid. In the demonstration board, this operation is performed by pressing a button. Once the button is pressed, the pressure measured at that moment is considered as 0 mbar. In a real application, there is no such a button to press; the zero reference is set by the main MCU through a dedicated software routine.
- STM8S103F2**  
 The entire process is controlled by a 20-pin, 8-bit STM8S103F2 microcontroller. The code size of the firmware is below 2 Kilobytes.

## 2.2 Schematic diagram

Figure 3. STEVAL-MKI111V1 circuit schematic - part 1

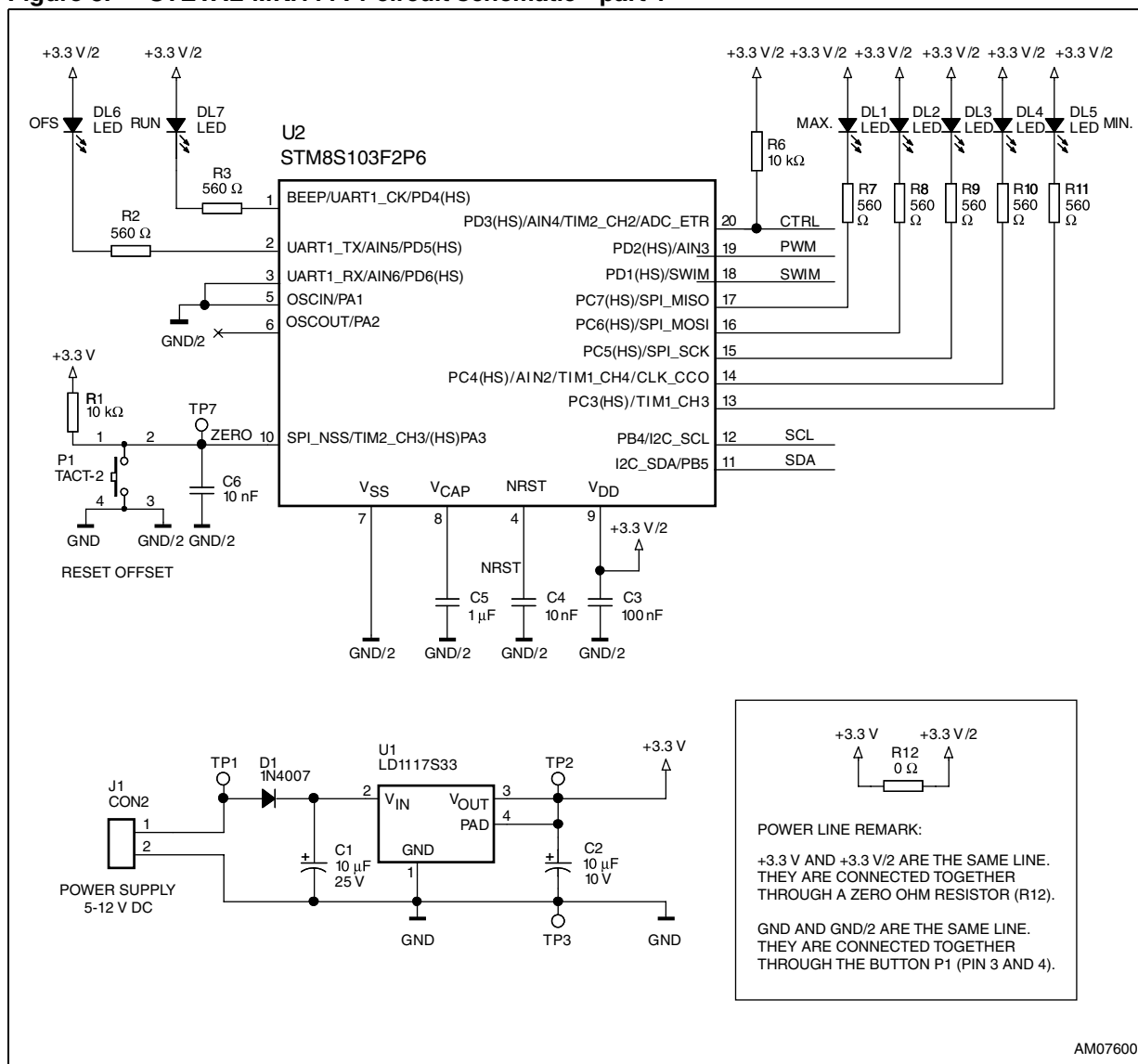

AM07600

Figure 4. STEVAL-MKI111V1 circuit schematic - part 2

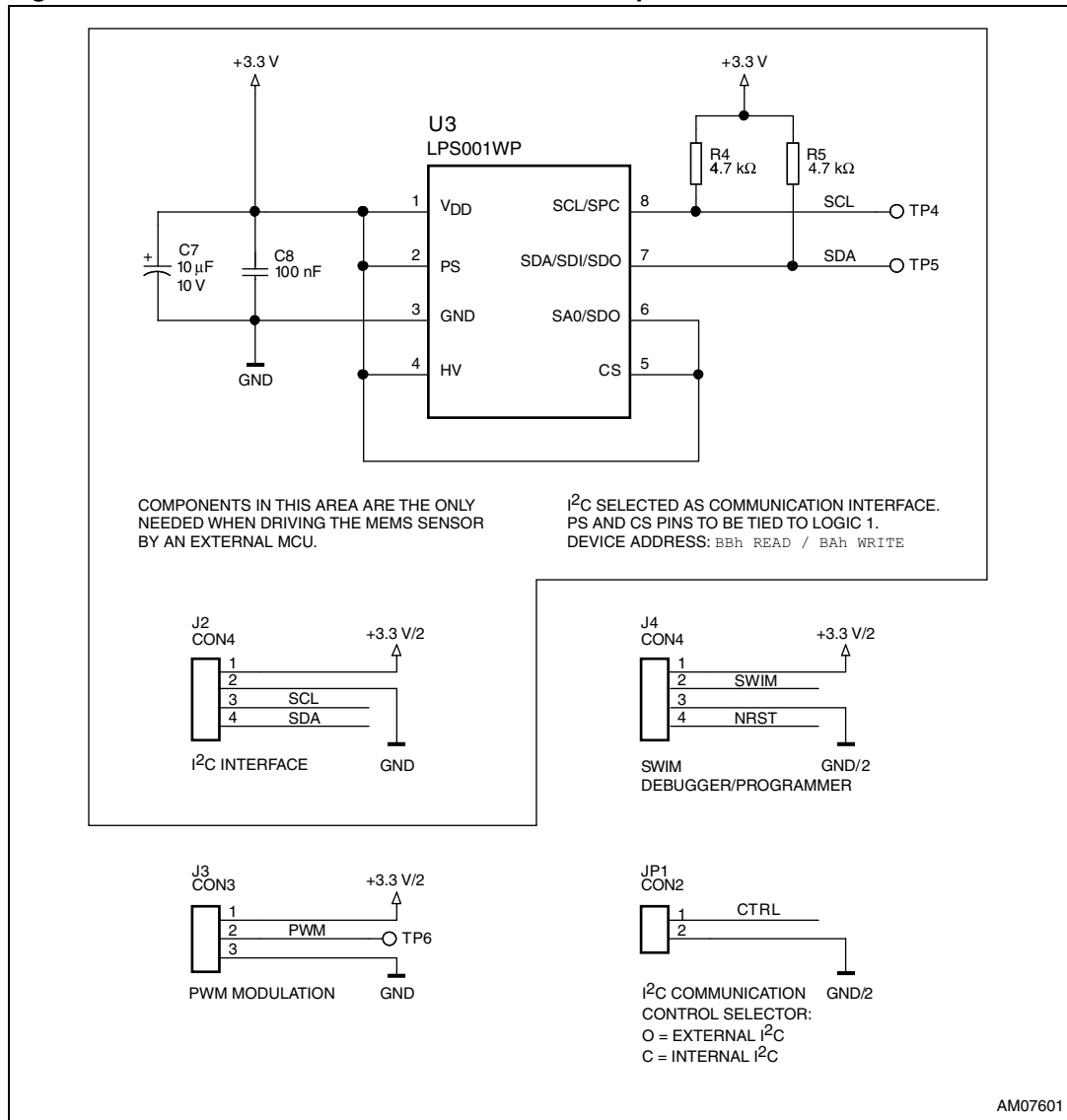

## 2.3 How the system works

The demonstration board functionality can be tested with or without the container. In fact, even if no container is connected to the demonstration board through the rubber tube, all signals are clearly visible by means of a scope. Pressure and temperature can also be read in real-time by connecting the demonstration board to an ST debugging tool with SWIM interface.

### 2.3.1 Startup

After powering up the demonstration board, the RUN LED turns on, indicating that the system is working correctly. The OFS LED blinks, indicating that the pressure reference has not been set yet. The LED bar is off.

### 2.3.2 Setting the pressure reference (zero, 0 mbar)

By pressing the P1 button, the system sets the pressure reference. The pressure reference is the one read by the MEMS at the moment the button is pressed.

Every time that button P1 is pressed, a new reference is set.

Once the reference is set, the OFS LED turns off, and the lower LED in the LED bar turns on.

From now on, the pressure signal is also available as PWM modulation (see [Section 2.3.3](#)).

### 2.3.3 Output signals

Once the pressure reference is set, the pressure signal is available as PWM modulation on connector J3. The signal frequency starts at 43 Hz, meaning 0 mbar. Changes in pressure modulate the frequency accordingly. An increase of 6 mbar means a decrease of 1 Hz in frequency change. Therefore, a frequency of 38 Hz means a pressure of 30 mbar.

This frequency range has been adopted to simulate electromechanical pressure sensors. In this way, it's very easy to replace it with the STEVAL-MKI111V1 demonstration board.

The signals coming from the MEMS sensor are also available on connector J2, although an external MCU must be connected through the I<sup>2</sup>C interface.

Additionally, the demonstration board can be connected to an ST debugging tool with SWIM interface to read in real-time the pressure and temperature data as variables (see also [Section 6](#)).

### 2.3.4 LED bar

The 5-step LED bar roughly shows the pressure that the MEMS sensor is actually measuring. Each LED means 6 mbar. Therefore the full range indicated by the LED bar is 30 mbar. In the case of a depression, the LED blinks instead. Therefore the full range shown by the LED bar is -30 mbar / 30 mbar.

### 3 Connectors, test pins and jumpers

*Figure 5* describes the connectors, test pins and jumpers of the STEVAL-MKI111V1 demonstration board.

**Figure 5. How to connect the STEVAL-MKI111V1**

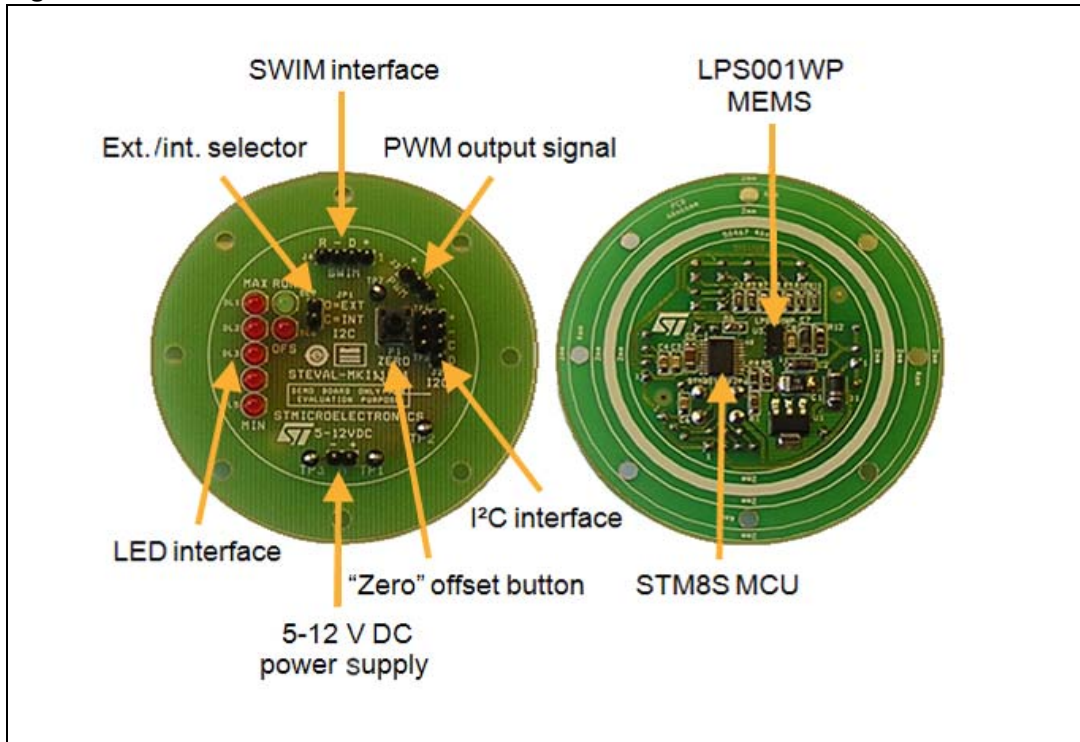

- The power supply must be applied to connector J1
- The ST debugging tool with SWIM interface must be connected to connector J4
- The I<sup>2</sup>C interface must be connected to connector J2
- The PWM output signal must be read on connector J3
- The I<sup>2</sup>C bus mode (internal or external) must be selected by jumper JP1

[Table 1](#) to [Table 5](#) provide a detailed description of the test pins, connectors and jumpers used in the demonstration board.

**Table 1. Connector pinout description**

Connector	Description
J1	Power supply
J2	I <sup>2</sup> C interface (see also <a href="#">Table 5</a> )
J3	PWM modulation (see also <a href="#">Table 4</a> )
J4	Debugging / programming interface (see also <a href="#">Table 3</a> )

**Table 2. Test points description**

Test point	Description
TP1	Power supply, positive pole
TP2	3.3 V DC (fixed voltage output from regulator)
TP3	Power supply, negative pole (GND)
TP4	I <sup>2</sup> C interface, serial clock, SCL
TP5	I <sup>2</sup> C interface, serial data, SDA
TP6	PWM modulation
TP7	Zero offset button

**Table 3. MCU programming connector (J4)**

Pin	Description
1	VDD / 5 VDC
2	SWIM / debug
3	GND
4	RST / NRST / RESET

**Table 4. PWM modulation connector (J3)**

Pin	Description
1	3.3 VDC
2	Output signal
3	GND

**Table 5. I<sup>2</sup>C interface connector (J5)**

<b>Pin</b>	<b>Description</b>
1	3.3 V DC
2	GND
3	Serial clock, SCL
4	Serial data, SDA

## 4 Bill of material

The complete list of components used to build the demonstration board is shown in [Table 6](#).

**Table 6. Bill of material**

Reference	Part	Supplier
C1	10 $\mu$ F, 25 V, case size B, SMD	
C2, C7	10 $\mu$ F, 10 V, case size A, SMD	
C3, C8	100 nF, 25 V, X7R, 0805 SMD	
C4, C6	10 nF, 25 V, X7R, 0805 SMD	
C5	1 $\mu$ F, 25 V, X7R, 1206 SMD	
DL1, DL2, DL3, DL4, DL5, DL6	LED, red, 5 mA, $\varnothing$ 3 mm	
DL7	LED, green, 5 mA, $\varnothing$ 3 mm	
D1	1N4007, SMA SMD	
J1, JP1	Stripline 2P, 2.54 mm	
J2, J4	Stripline 4P, 2.54 mm	
J3	Stripline 3P, 2.54 mm	
P1	Tact switch, 6x6 mm, through hole	
R1, R6	10 k $\Omega$ , 1%, 0805 SMD	
R2, R3, R7, R8, R9, R10, R11	560 $\Omega$ , 1%, 0805 SMD	
R4, R5	4.7 k $\Omega$ , 1%, 0805 SMD	
R12	0 $\Omega$ , 1206 SMD	
TP1, TP2, TP3, TP4, TP5, TP6, TP7	Test point	
U1	LD1117S33TR, SOT-223	STMicroelectronics
U2	STM8S103F2P6, TSSOP20	STMicroelectronics
U3	LPS001WP, HCLGA-8L	STMicroelectronics

## 5 The STEVAL-MKI111V1 layout

The STEVAL-MKI111V1 is a standard, single-layer, coppered PCB with a copper thickness of approximately 35 µm. The PCB material is FR-4.

PCB dimensions:

- Length: 66 mm
- Width: 66 mm
- Thickness: 2 mm

Figure 6. STEVAL-MKI111V1 silk-screen (top)

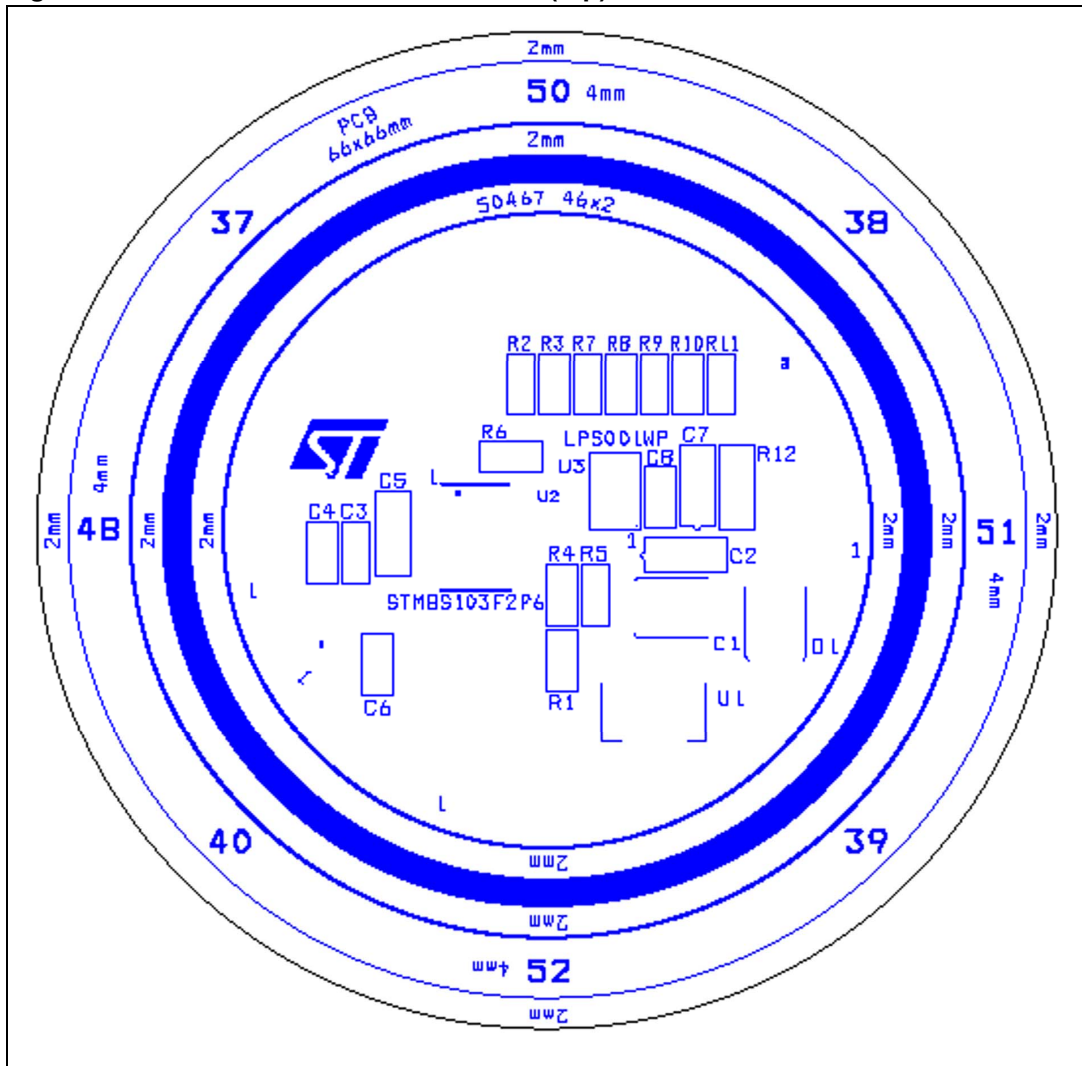



Figure 7. STEVAL-MKI111V1 silk-screen (bottom)

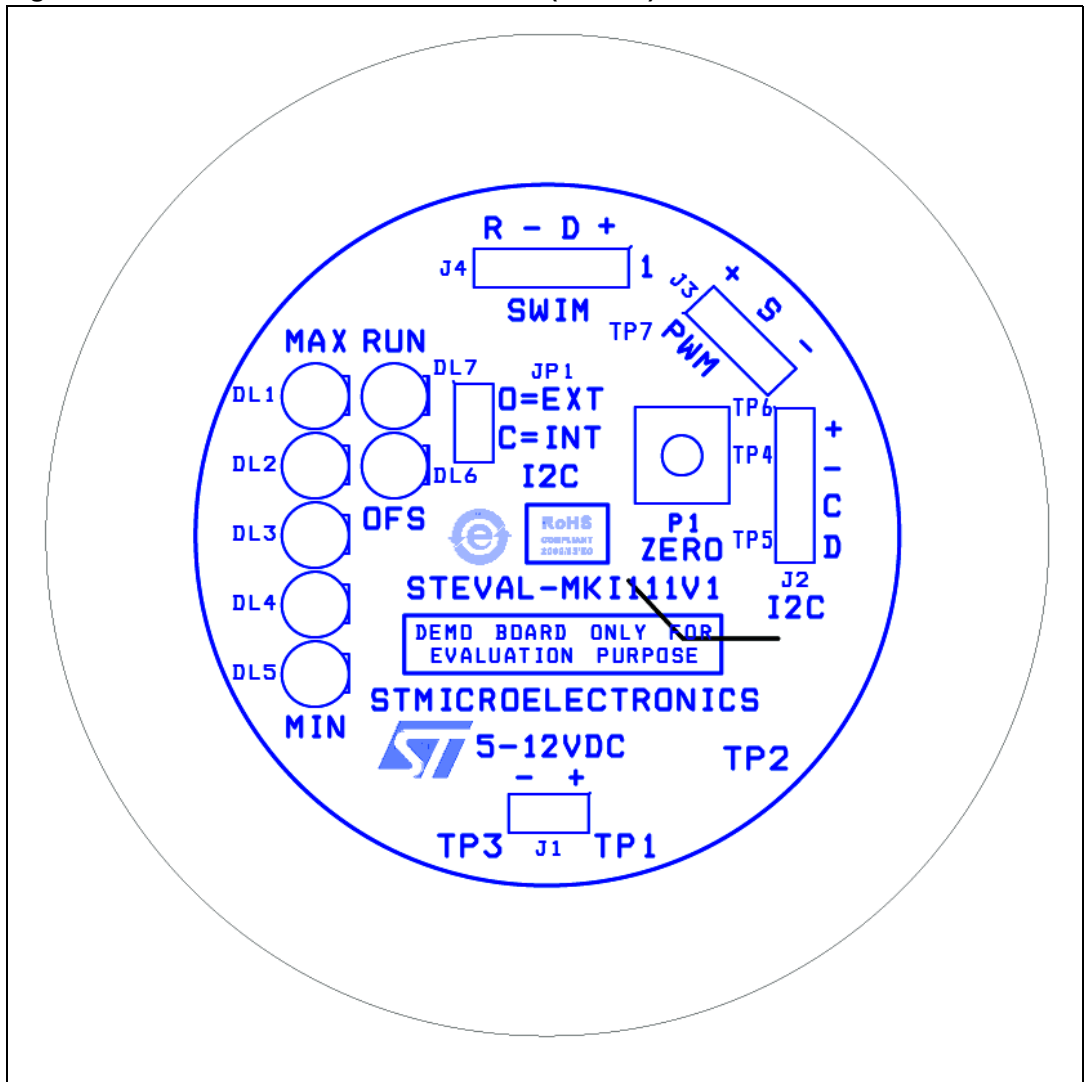

Figure 8. STEVAL-MKI111V1 top layer

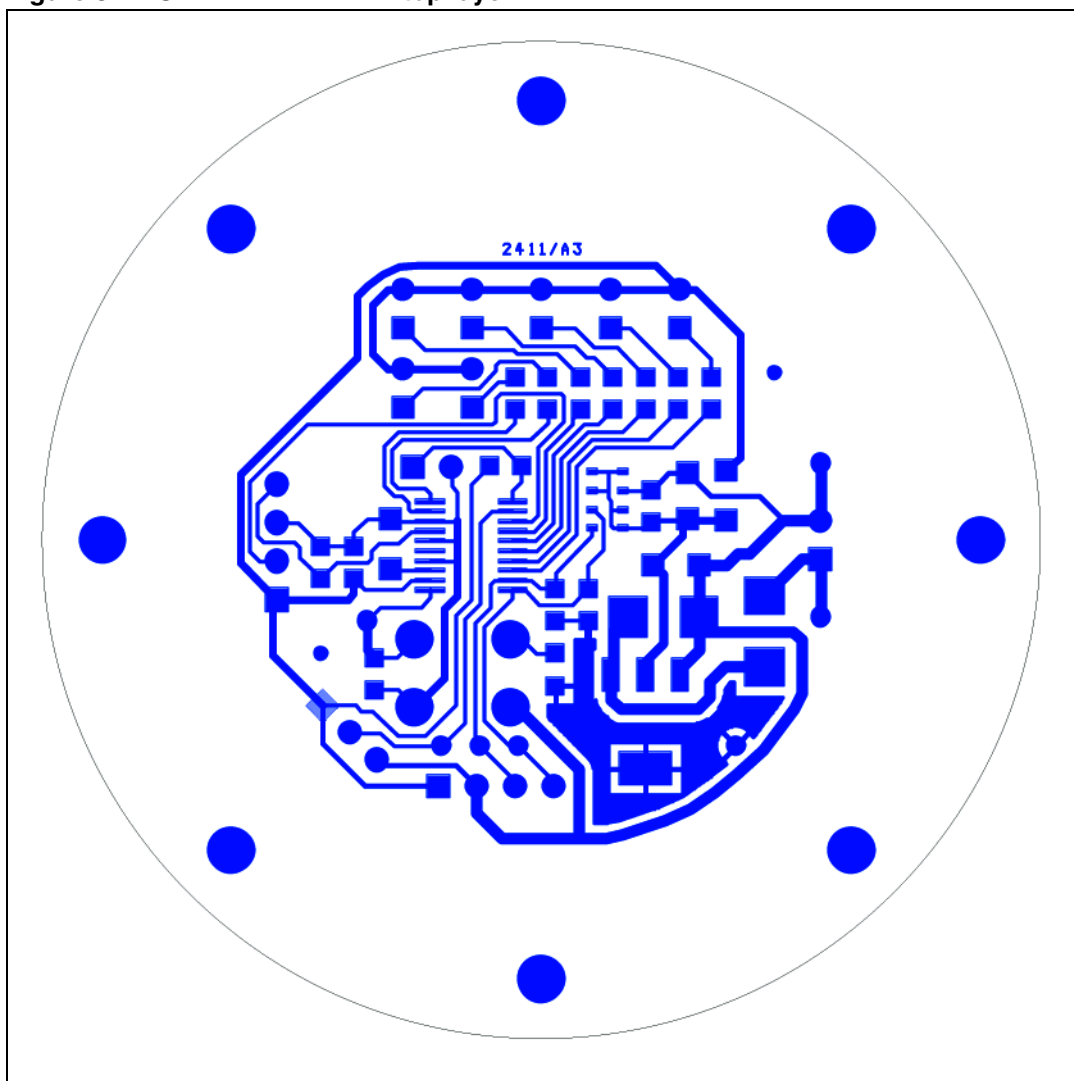

Figure 9. STEVAL-MKI111V1 top view

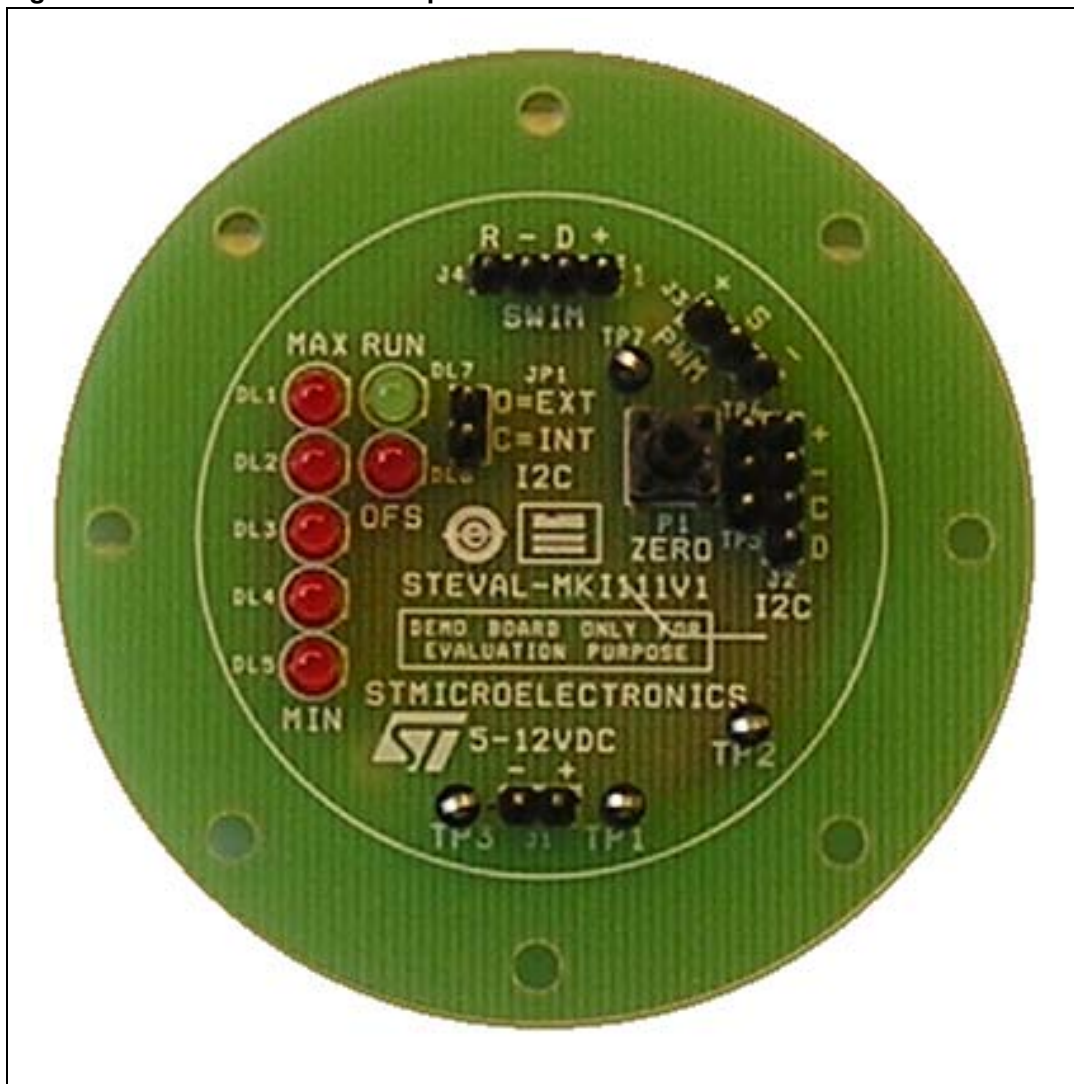

Figure 10. STEVAL-MKI111V1 bottom view



## 6 Software customization and real-time debug

The STEVAL-MKI111V1 demonstration board can be fully adapted to the container the user intends to test. The firmware included in the demonstration board kit is provided as open source. The demonstration board can be connected to an ST debugging tool with SWIM interface in order to read in real-time the signals coming from the MEMS sensor.

### 6.1 Pressure signal

The pressure read by the MEMS sensor is stored in a variable which is constantly updated in an infinite loop. To avoid oscillations and reduce the error introduced by false readings, the variable holds an average pressure value, which is obtained out of 8 raw readings coming from the MEMS sensor. Pressure readings are expressed as absolute values.

Pressure signal: `Average_Pressure`

### 6.2 Temperature signal

The temperature read by the MEMS sensor is stored in a variable which is constantly updated in an infinite loop. To avoid oscillations and reduce the error introduced by false readings, the variable holds an average temperature value, which is obtained out of 8 raw readings coming from the MEMS sensor. Temperature readings are expressed as 2's complement numbers.

Pressure signal: `Average_Temperature`

## 7 Ordering information

The demonstration board is available through the standard STMicroelectronics ordering system. The order code is: STEVAL-MKI111V1. The kit includes an assembled demonstration board screwed to the metal box, the source code in C language, and all related documentation. The rubber tube to connect the container to the demonstration board is also included in the kit. The container itself is not included in the kit.

## 8 References

1. STM8S103F2 datasheet
2. LPS331AP datasheet
3. LD1117 datasheet

## 9 Revision history

**Table 7. Document revision history**

Date	Revision	Changes
16-Mar-2012	1	Initial release.

**Please Read Carefully:**

Information in this document is provided solely in connection with ST products. STMicroelectronics NV and its subsidiaries ("ST") reserve the right to make changes, corrections, modifications or improvements, to this document, and the products and services described herein at any time, without notice.

All ST products are sold pursuant to ST's terms and conditions of sale.

Purchasers are solely responsible for the choice, selection and use of the ST products and services described herein, and ST assumes no liability whatsoever relating to the choice, selection or use of the ST products and services described herein.

No license, express or implied, by estoppel or otherwise, to any intellectual property rights is granted under this document. If any part of this document refers to any third party products or services it shall not be deemed a license grant by ST for the use of such third party products or services, or any intellectual property contained therein or considered as a warranty covering the use in any manner whatsoever of such third party products or services or any intellectual property contained therein.

**UNLESS OTHERWISE SET FORTH IN ST'S TERMS AND CONDITIONS OF SALE ST DISCLAIMS ANY EXPRESS OR IMPLIED WARRANTY WITH RESPECT TO THE USE AND/OR SALE OF ST PRODUCTS INCLUDING WITHOUT LIMITATION IMPLIED WARRANTIES OF MERCHANTABILITY, FITNESS FOR A PARTICULAR PURPOSE (AND THEIR EQUIVALENTS UNDER THE LAWS OF ANY JURISDICTION), OR INFRINGEMENT OF ANY PATENT, COPYRIGHT OR OTHER INTELLECTUAL PROPERTY RIGHT.**

**UNLESS EXPRESSLY APPROVED IN WRITING BY TWO AUTHORIZED ST REPRESENTATIVES, ST PRODUCTS ARE NOT RECOMMENDED, AUTHORIZED OR WARRANTED FOR USE IN MILITARY, AIR CRAFT, SPACE, LIFE SAVING, OR LIFE SUSTAINING APPLICATIONS, NOR IN PRODUCTS OR SYSTEMS WHERE FAILURE OR MALFUNCTION MAY RESULT IN PERSONAL INJURY, DEATH, OR SEVERE PROPERTY OR ENVIRONMENTAL DAMAGE. ST PRODUCTS WHICH ARE NOT SPECIFIED AS "AUTOMOTIVE GRADE" MAY ONLY BE USED IN AUTOMOTIVE APPLICATIONS AT USER'S OWN RISK.**

Resale of ST products with provisions different from the statements and/or technical features set forth in this document shall immediately void any warranty granted by ST for the ST product or service described herein and shall not create or extend in any manner whatsoever, any liability of ST.

ST and the ST logo are trademarks or registered trademarks of ST in various countries.

Information in this document supersedes and replaces all information previously supplied.

The ST logo is a registered trademark of STMicroelectronics. All other names are the property of their respective owners.

© 2012 STMicroelectronics - All rights reserved

STMicroelectronics group of companies

Australia - Belgium - Brazil - Canada - China - Czech Republic - Finland - France - Germany - Hong Kong - India - Israel - Italy - Japan - Malaysia - Malta - Morocco - Philippines - Singapore - Spain - Sweden - Switzerland - United Kingdom - United States of America

[www.st.com](http://www.st.com)

