



Chipsmall Limited consists of a professional team with an average of over 10 year of expertise in the distribution of electronic components. Based in Hongkong, we have already established firm and mutual-benefit business relationships with customers from,Europe,America and south Asia,supplying obsolete and hard-to-find components to meet their specific needs.

With the principle of “Quality Parts,Customers Priority,Honest Operation,and Considerate Service”,our business mainly focus on the distribution of electronic components. Line cards we deal with include Microchip,ALPS,ROHM,Xilinx,Pulse,ON,Everlight and Freescale. Main products comprise IC,Modules,Potentiometer,IC Socket,Relay,Connector.Our parts cover such applications as commercial,industrial, and automotives areas.

We are looking forward to setting up business relationship with you and hope to provide you with the best service and solution. Let us make a better world for our industry!



Contact us

Tel: +86-755-8981 8866 Fax: +86-755-8427 6832

Email & Skype: info@chipsmall.com Web: www.chipsmall.com

Address: A1208, Overseas Decoration Building, #122 Zhenhua RD., Futian, Shenzhen, China





STEVAL-SPBT2ATV3

USB dongle for the Bluetooth® class 2 SPBT2532C2.AT2 module

Data brief

Features

- Based on the SPBT2532C2.AT2 class 2 module
- Bluetooth® specification compliant V2.1+EDR
- USB interface and power supply
- Supported reprogrammability via USB interface
- SMD antenna and reset button onboard
- User interface: AT2 command set supporting data communication with Android smartphone and Apple iOS Bluetooth® enabled devices
- RoHS compliant

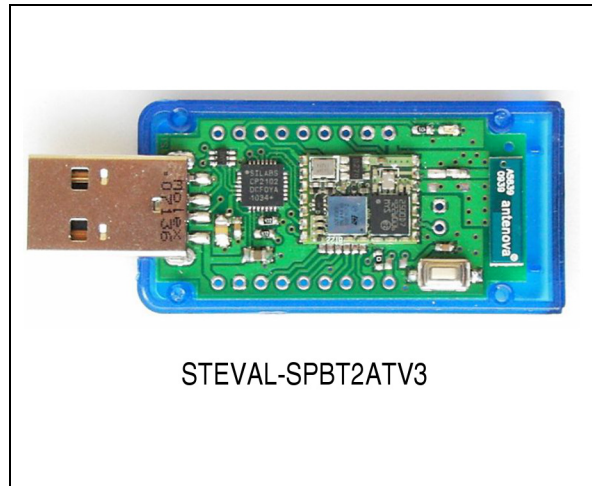

Description

The STEVAL-SPBT2ATV3 demonstration board is a design tool to evaluate the SPBT2532C2.AT2 module in a quick and simple way.

The dongle includes the RF antenna and the USB connector.

The USB connector is used to connect the dongle to a PC, to access the Bluetooth® module, and to supply the dongle.

The STEVAL-SPBT2ATV3 includes downloaded FW, enabling the user to create a Bluetooth® link with simple AT commands.

The AT command list is detailed in the user manual UM1547.

The AN3189 application note describes how to get started with the STEVAL-SPBT2ATV3.

The SPBT2532C2.AT2-based dongle is a demonstration tool only, to be used strictly for evaluation purposes. It is not a product in itself.

1 Recommended operating conditions

Table 1. Recommended operating conditions

Symbol	Parameter	Conditions	Min.	Typ	Max	Unit
VDD	Board supply voltage	-40 °C < T < 85 °C	4	5	6	V
Top	Operating case temperature range		-40		+85	°C

2 I/O connections

2.1 PAD description

Other than the USB plug, some pads are also available. In fact TP1 and TP2 pads make the SPBT2532C2.AT2 pins available to the user.

Figure 1. Available pads

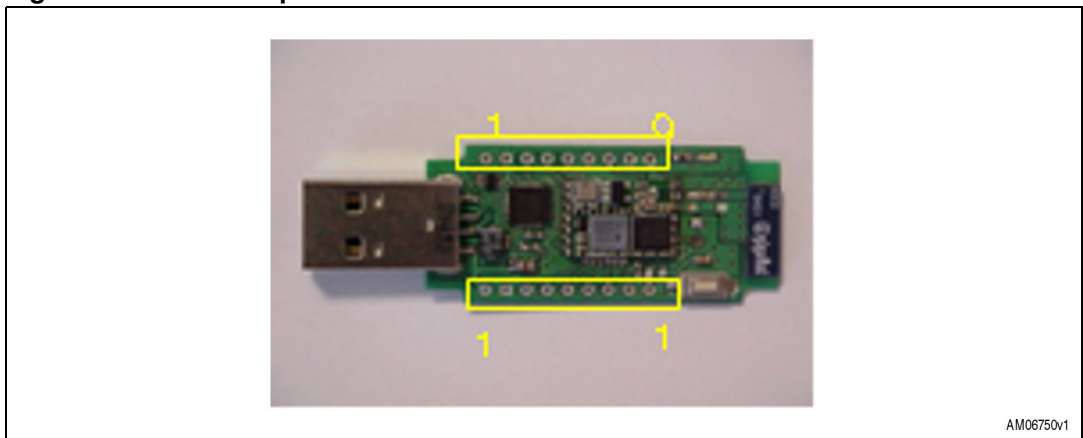

AM06750v1

[Table 2](#) lists the meaning of these pads.

Table 2. Pad connections

Pads		Description
TP	1	Reset - connected in parallel to onboard reset switch
	2	SPBT2532C2.AT2 supply voltage
	3	Boot pin - used for firmware downloading - used for testing purposes
	4	GPIO01 - general purpose I/O – LED5 is connected to this pin
	5	GPIO02 - general purpose I/O – LED4 is connected to this pin
	6	GPIO03 - general purpose I/O – LED3 is connected to this pin
	7	GPIO04 - general purpose I/O – LED2 is connected to this pin
	8	GND
	9	GND
	10	USB + (5 V)
	11	GND
	12	Used for testing purposes
	13	Used for testing purposes
	14	Used for testing purposes
	15	Used for testing purposes
	16	Used for testing purposes
	17	Used for testing purposes
	18	3.3 V

2.2 Reset switch

A reset switch SW1 is present on the dongle. When SW1 is pushed SPBT2532C2.AT is forced to reset.

The following prompt is displayed on the screen:

- AT-AB - command mode
- AT-AB BDAAddress xxxxxxxxxxxx

Figure 2. Reset switch

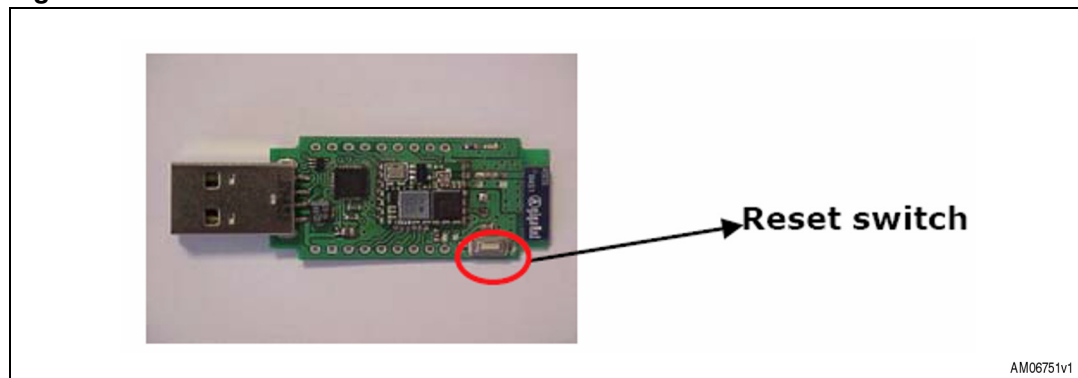

3 Dongle layout

Figure 3. Dongle component layout

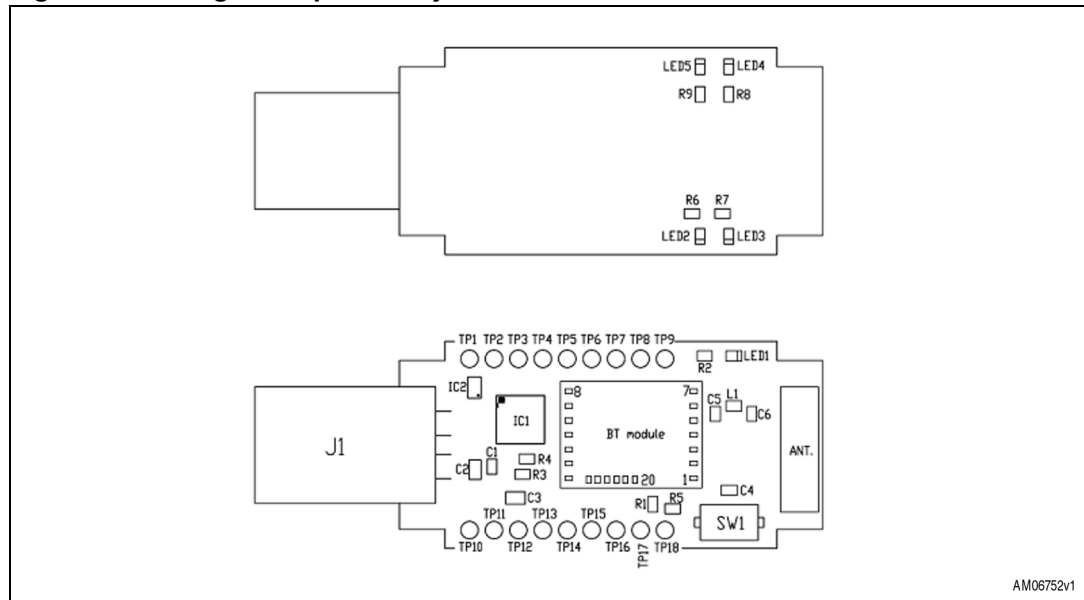

AM06752v1

4 Dongle schematic

Figure 4. Dongle electrical drawing

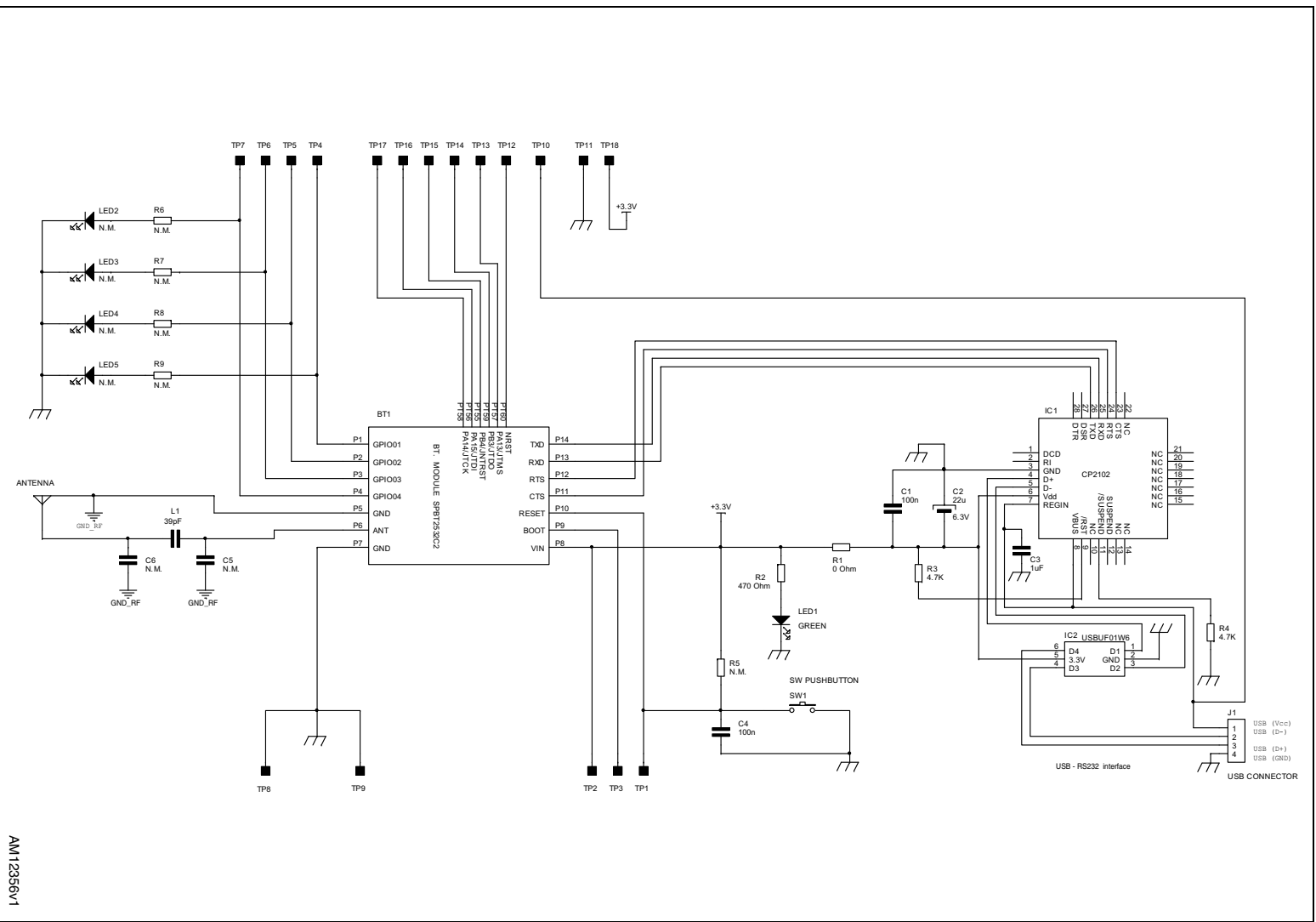

AM12356v1



5 Revision history

Table 3. Document revision history

Date	Revision	Changes
11-Jun-2012	1	Initial release.
25-Jun-2012	2	– Title and description modified to improve readability – Added: <i>Section 1: Recommended operating conditions</i> and <i>Section 2: I/O connections</i>

Please Read Carefully:

Information in this document is provided solely in connection with ST products. STMicroelectronics NV and its subsidiaries ("ST") reserve the right to make changes, corrections, modifications or improvements, to this document, and the products and services described herein at any time, without notice.

All ST products are sold pursuant to ST's terms and conditions of sale.

Purchasers are solely responsible for the choice, selection and use of the ST products and services described herein, and ST assumes no liability whatsoever relating to the choice, selection or use of the ST products and services described herein.

No license, express or implied, by estoppel or otherwise, to any intellectual property rights is granted under this document. If any part of this document refers to any third party products or services it shall not be deemed a license grant by ST for the use of such third party products or services, or any intellectual property contained therein or considered as a warranty covering the use in any manner whatsoever of such third party products or services or any intellectual property contained therein.

UNLESS OTHERWISE SET FORTH IN ST'S TERMS AND CONDITIONS OF SALE ST DISCLAIMS ANY EXPRESS OR IMPLIED WARRANTY WITH RESPECT TO THE USE AND/OR SALE OF ST PRODUCTS INCLUDING WITHOUT LIMITATION IMPLIED WARRANTIES OF MERCHANTABILITY, FITNESS FOR A PARTICULAR PURPOSE (AND THEIR EQUIVALENTS UNDER THE LAWS OF ANY JURISDICTION), OR INFRINGEMENT OF ANY PATENT, COPYRIGHT OR OTHER INTELLECTUAL PROPERTY RIGHT.

UNLESS EXPRESSLY APPROVED IN WRITING BY TWO AUTHORIZED ST REPRESENTATIVES, ST PRODUCTS ARE NOT RECOMMENDED, AUTHORIZED OR WARRANTED FOR USE IN MILITARY, AIR CRAFT, SPACE, LIFE SAVING, OR LIFE SUSTAINING APPLICATIONS, NOR IN PRODUCTS OR SYSTEMS WHERE FAILURE OR MALFUNCTION MAY RESULT IN PERSONAL INJURY, DEATH, OR SEVERE PROPERTY OR ENVIRONMENTAL DAMAGE. ST PRODUCTS WHICH ARE NOT SPECIFIED AS "AUTOMOTIVE GRADE" MAY ONLY BE USED IN AUTOMOTIVE APPLICATIONS AT USER'S OWN RISK.

Resale of ST products with provisions different from the statements and/or technical features set forth in this document shall immediately void any warranty granted by ST for the ST product or service described herein and shall not create or extend in any manner whatsoever, any liability of ST.

ST and the ST logo are trademarks or registered trademarks of ST in various countries.

Information in this document supersedes and replaces all information previously supplied.

The ST logo is a registered trademark of STMicroelectronics. All other names are the property of their respective owners.

© 2012 STMicroelectronics - All rights reserved

STMicroelectronics group of companies

Australia - Belgium - Brazil - Canada - China - Czech Republic - Finland - France - Germany - Hong Kong - India - Israel - Italy - Japan - Malaysia - Malta - Morocco - Philippines - Singapore - Spain - Sweden - Switzerland - United Kingdom - United States of America

www.st.com