



Chipsmall Limited consists of a professional team with an average of over 10 year of expertise in the distribution of electronic components. Based in Hongkong, we have already established firm and mutual-benefit business relationships with customers from,Europe,America and south Asia,supplying obsolete and hard-to-find components to meet their specific needs.

With the principle of "Quality Parts,Customers Priority,Honest Operation,and Considerate Service",our business mainly focus on the distribution of electronic components. Line cards we deal with include Microchip,ALPS,ROHM,Xilinx,Pulse,ON,Everlight and Freescale. Main products comprise IC,Modules,Potentiometer,IC Socket,Relay,Connector.Our parts cover such applications as commercial,industrial, and automotives areas.

We are looking forward to setting up business relationship with you and hope to provide you with the best service and solution. Let us make a better world for our industry!



Contact us

Tel: +86-755-8981 8866 Fax: +86-755-8427 6832

Email & Skype: info@chipsmall.com Web: www.chipsmall.com

Address: A1208, Overseas Decoration Building, #122 Zhenhua RD., Futian, Shenzhen, China



STB100N10F7, STD100N10F7, STF100N10F7, STP100N10F7

N-channel 100 V, 0.0068 Ω typ., 80 A, STripFET™ VII DeepGATE™
Power MOSFET in D²PAK, DPAK, TO-220FP and TO-220

Datasheet - production data

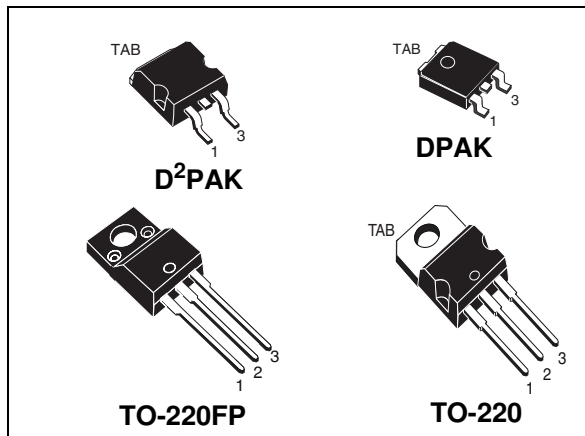
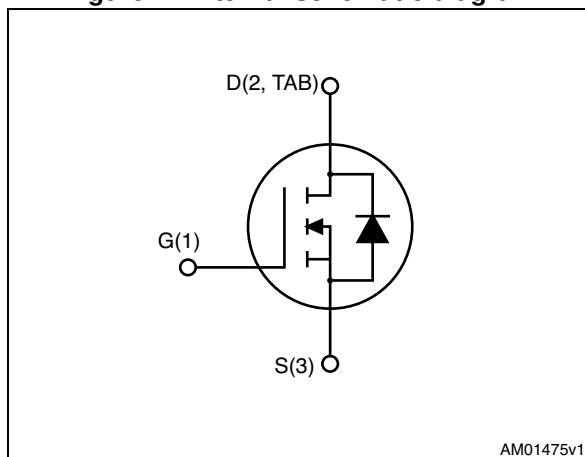

Figure 1. Internal schematic diagram



Features

Order codes	V _{DS}	R _{DS(on)} max	I _D	P _{TOT}
STB100N10F7	100 V	0.008 Ω	80 A	120 W
STD100N10F7			80 A	120 W
STF100N10F7			45 A	30 W
STP100N10F7			80 A	150 W

- Ultra low on-resistance
- 100% avalanche tested

Applications

- Switching applications

Description

These devices utilize the 7th generation of design rules of ST's proprietary STripFET™ technology, with a new gate structure. The resulting Power MOSFET exhibits the lowest R_{DS(on)} in all packages.

Table 1. Device summary

Order codes	Marking	Packages	Packaging
STB100N10F7	100N10F7	D ² PAK	Tape and reel
STD100N10F7		DPAK	Tape and reel
STF100N10F7		TO-220FP	Tube
STP100N10F7		TO-220	Tube

Contents

1	Electrical ratings	3
2	Electrical characteristics	4
	2.1 Electrical characteristics (curves)	6
3	Test circuits	9
4	Package mechanical data	10
5	Packaging mechanical data	19
6	Revision history	22

1 Electrical ratings

Table 2. Absolute maximum ratings

Symbol	Parameter	Value			Unit
		DPAK	TO-220FP	TO-220 D ² PAK	
V_{DS}	Drain-source voltage	100			V
V_{GS}	Gate-source voltage	± 20			V
I_D	Drain current (continuous) at $T_C = 25\text{ °C}$	80	45 ⁽¹⁾	80	A
I_D	Drain current (continuous) at $T_C = 100\text{ °C}$	62	32 ⁽¹⁾	70	A
I_{DM} ⁽²⁾	Drain current (pulsed)	320	180	320	A
P_{TOT} ⁽¹⁾	Total dissipation at $T_C = 25\text{ °C}$	120	30	150	W
T_J	Operating junction temperature	-55 to 175			°C
T_{stg}	Storage temperature				°C

1. This value is limited by package.
2. Pulse width limited by safe operating area.

Table 3. Thermal resistance

Symbol	Parameter	Value				Unit
		D ² PAK	DPAK	TO-220FP	TO-220	
$R_{thj-case}$	Thermal resistance junction-case	1	1.25	5	1	°C/W
$R_{thj-amb}$	Thermal resistance junction-ambient			62.50		°C/W
$R_{thj-pcb}$ ⁽¹⁾	Thermal resistance junction-pcb	30	50			°C/W

1. When mounted on FR-4 board of 1inch², 2oz Cu, t < 10 sec

Table 4. Avalanche characteristics

Symbol	Parameter	Value	Unit
E_{AS}	Single pulse avalanche energy ($T_J = 25\text{ °C}$, $L = 3.5\text{ mH}$, $I_{AS} = 15\text{ A}$, $V_{DD} = 50\text{ V}$, $V_{GS} = 10\text{ V}$)	400	mJ

2 Electrical characteristics

($T_{CASE}=25\text{ °C}$ unless otherwise specified)

Table 5. On/off states

Symbol	Parameter	Test conditions	Min.	Typ.	Max.	Unit
$V_{(BR)DSS}$	Drain-source breakdown voltage ($V_{GS}=0$)	$I_D = 250\ \mu A$	100		-	V
I_{DSS}	Zero gate voltage drain current ($V_{GS}=0$)	$V_{DS} = 100\text{ V}$ $V_{DS} = 100\text{ V}; T_C=125\text{ °C}$			1 100	μA μA
I_{GSS}	Gate body leakage current ($V_{DS}=0$)	$V_{GS} = 20\text{ V}$			100	nA
$V_{GS(th)}$	Gate threshold voltage	$V_{DS}=V_{GS}, I_D = 250\ \mu A$	2.5		4.5	V
$R_{DS(on)}$	Static drain-source on-resistance	For D ² PAK, DPAK and TO-220 $V_{GS}=10\text{ V}, I_D=40\text{ A}$ For TO-220-FP $V_{GS}=10\text{ V}, I_D=22.5\text{ A}$		0.0068	0.008	Ω

Table 6. Dynamic

Symbol	Parameter	Test conditions	Min.	Typ.	Max.	Unit
C_{iss}	Input capacitance	$V_{DS}=50\text{ V}, f=1\text{ MHz}, V_{GS}=0$	-	4369	-	pF
C_{oss}	Output capacitance		-	823	-	pF
C_{rss}	Reverse transfer capacitance		-	36	-	pF
Q_g	Total gate charge	$V_{DD}=50\text{ V}, I_D=80\text{ A}$	-	61	-	nC
Q_{gs}	Gate-source charge	$V_{GS}=10\text{ V}$	-	26	-	nC
Q_{gd}	Gate-drain charge	Figure 18	-	13	-	nC

Table 7. Switching times

Symbol	Parameter	Test conditions	Min.	Typ.	Max.	Unit
$t_{d(on)}$	Turn-on delay time	$V_{DD}=50\text{ V}, I_D=40\text{ A}, R_G=4.7\ \Omega, V_{GS}=10\text{ V}$ Figure 17	-	27	-	ns
t_r	Rise time		-	40	-	ns
$t_{d(off)}$	Turn-off delay time		-	46	-	ns
t_f	Fall time		-	15	-	ns

Table 8. Source drain diode

Symbol	Parameter	Test conditions	Min	Typ.	Max	Unit
I_{SD}	Source-drain current		-		80	A
$I_{SDM}^{(1)}$	Source-drain current (pulsed)		-		320	A
$V_{SD}^{(2)}$	Forward on voltage	$I_{SD} = 80 \text{ A}$, $V_{GS} = 0$	-		1.2	V
t_{rr}	Reverse recovery time	$I_{SD} = 80 \text{ A}$, $di/dt = 100 \text{ A}/\mu\text{s}$, $V_{DD} = 80 \text{ V}$, $T_j = 150 \text{ }^\circ\text{C}$	-	77		ns
Q_{rr}	Reverse recovery charge		-	146		nC
I_{RRM}	Reverse recovery current		-	4		A

1. Pulse width limited by safe operating area
2. Pulsed: pulse duration=300 μs , duty cycle 1.5%

2.1 Electrical characteristics (curves)

Figure 2. Safe operating area for DPAK

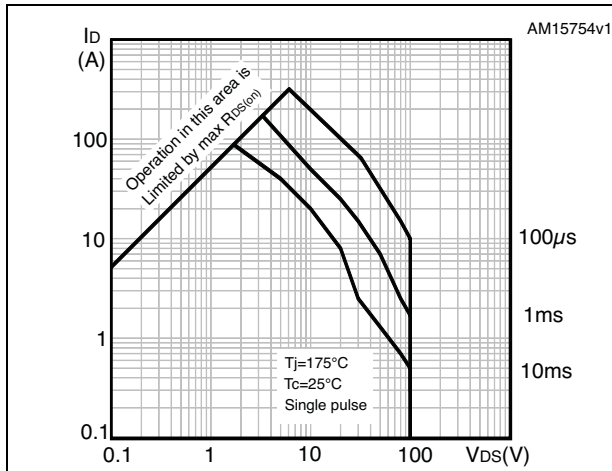

Figure 3. Thermal impedance for DPAK

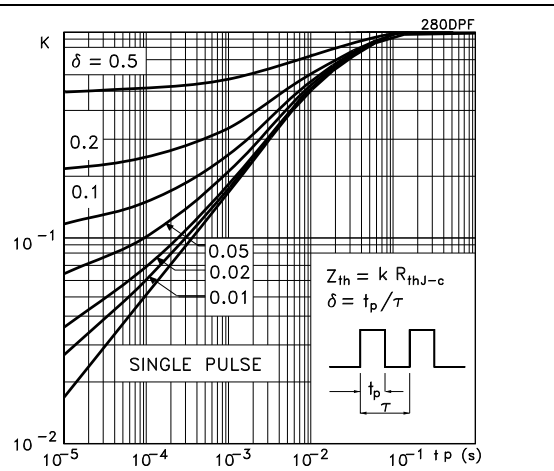

Figure 4. Safe operating area for TO-220FP

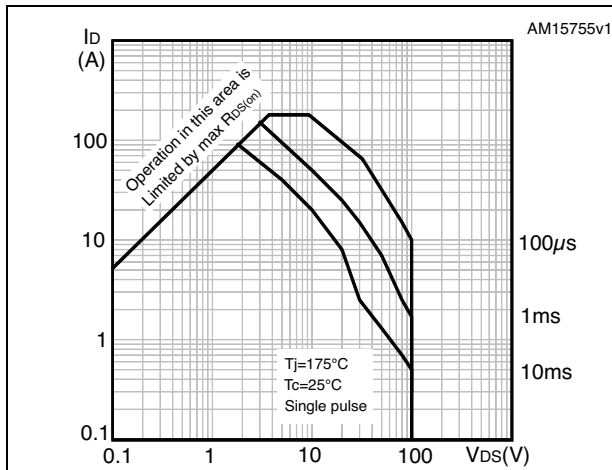

Figure 5. Thermal impedance for TO-220FP

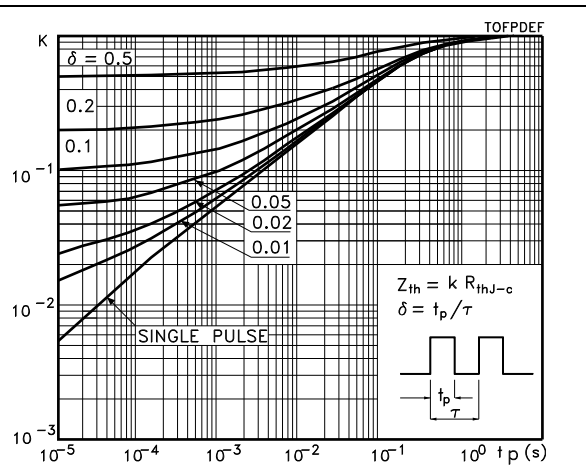

Figure 6. Safe operating area for D²PAK and TO-220

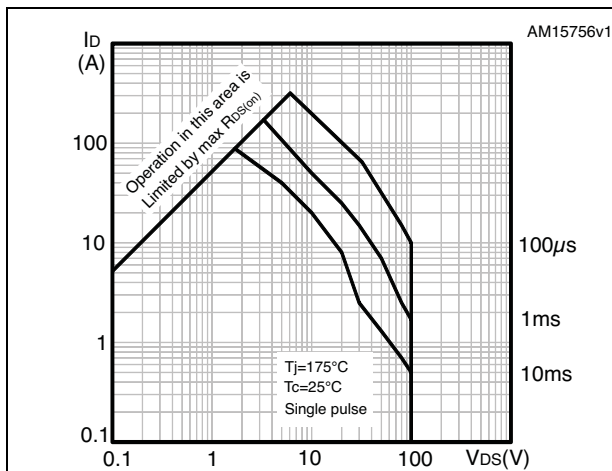

Figure 7. Thermal impedance for D²PAK and TO-220

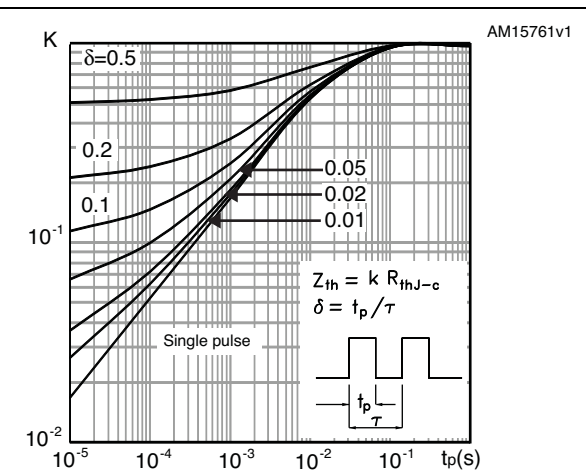

Figure 8. Output characteristics

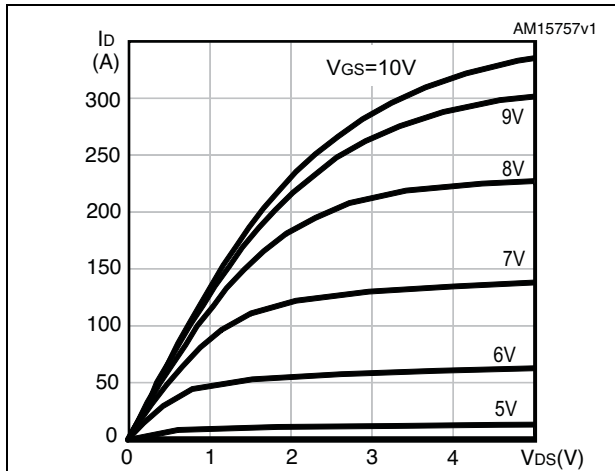

Figure 9. Transfer characteristics

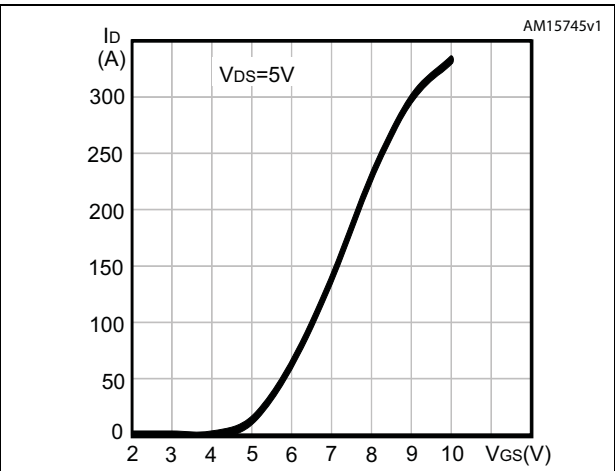

Figure 10. Normalized $V_{(BR)DSS}$ vs temperature

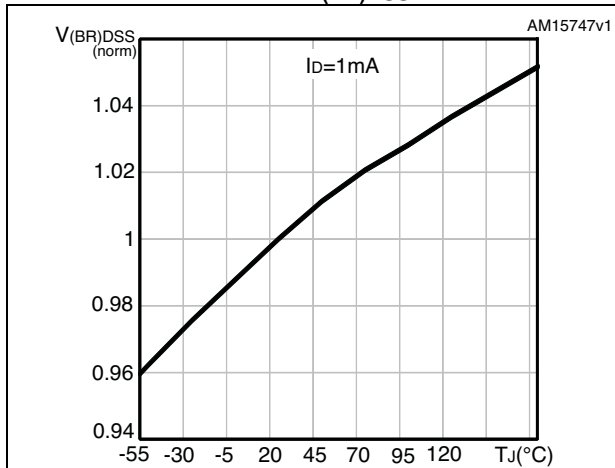

Figure 11. Static drain-source on-resistance

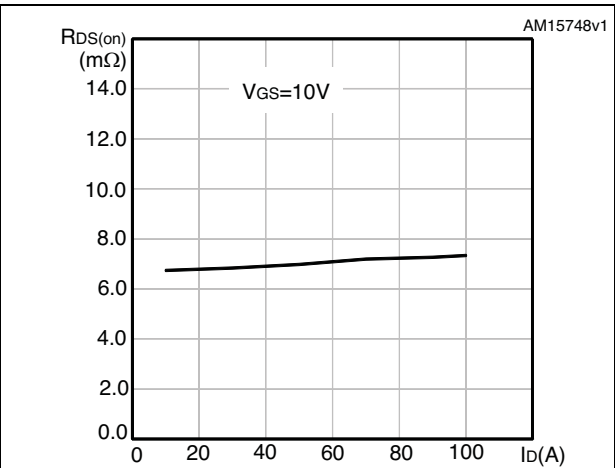

Figure 12. Gate charge vs gate-source voltage

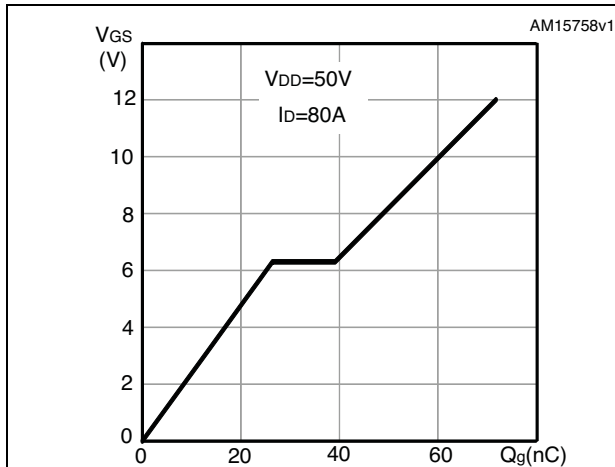

Figure 13. Capacitance variations

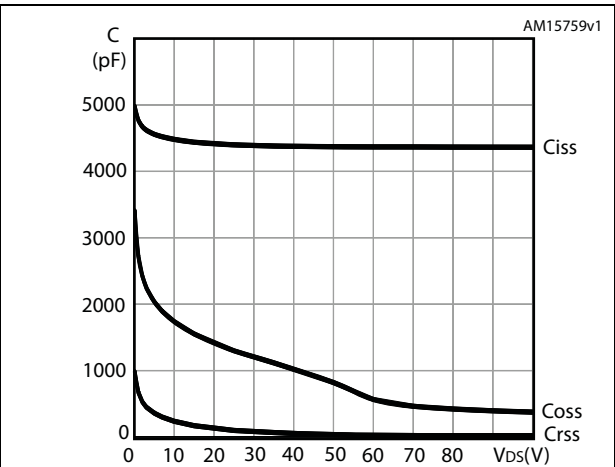

Figure 14. Normalized gate threshold voltage vs temperature

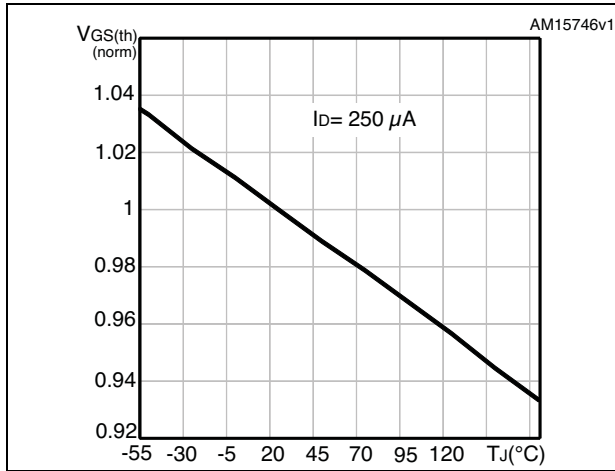

Figure 15. Normalized on-resistance vs temperature

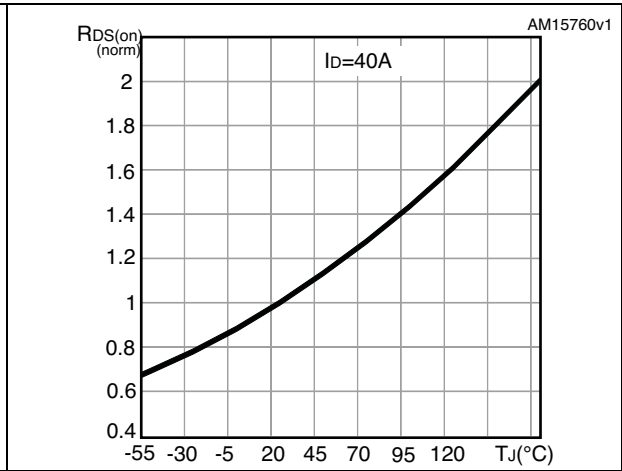
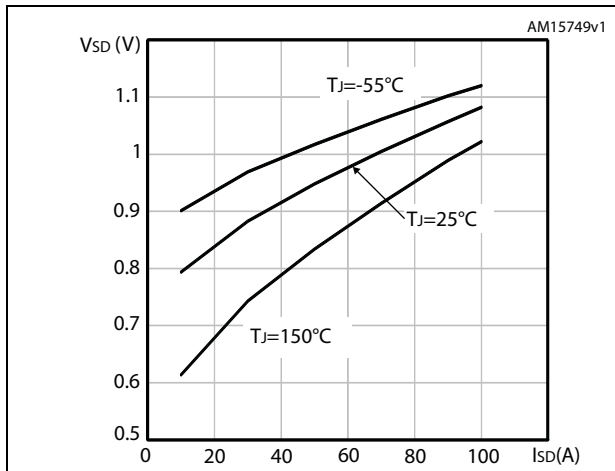

Figure 16. Source-drain diode forward characteristics



3 Test circuits

Figure 17. Switching times test circuit for resistive load

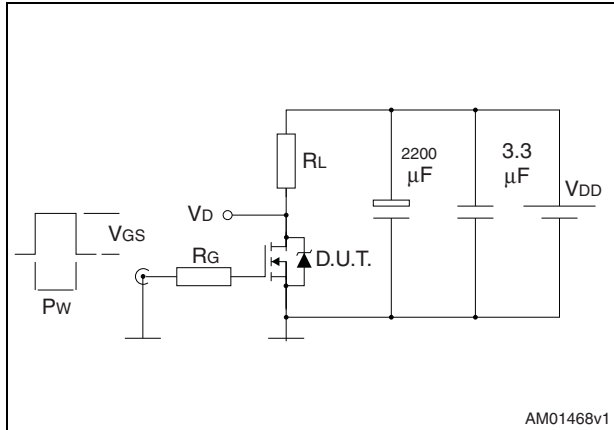

Figure 18. Gate charge test circuit

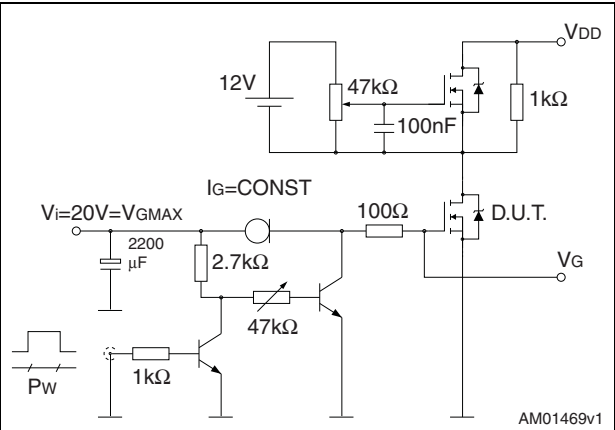

Figure 19. Test circuit for inductive load switching and diode recovery times

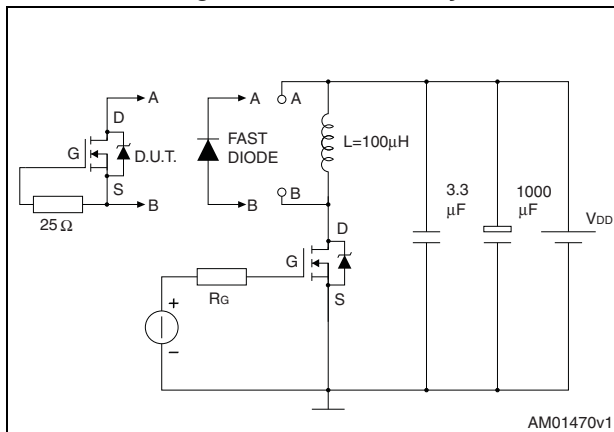

Figure 20. Unclamped inductive load test circuit

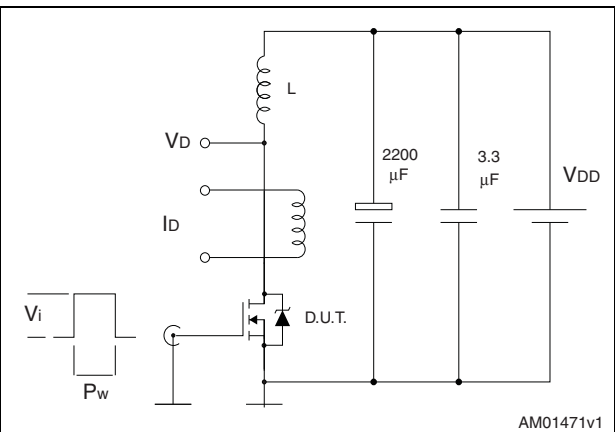

Figure 21. Unclamped inductive waveform

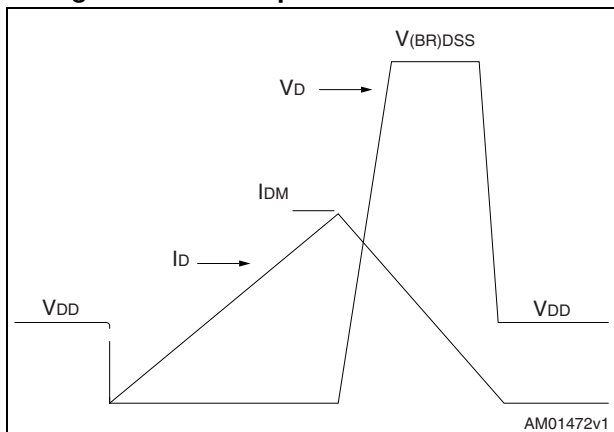
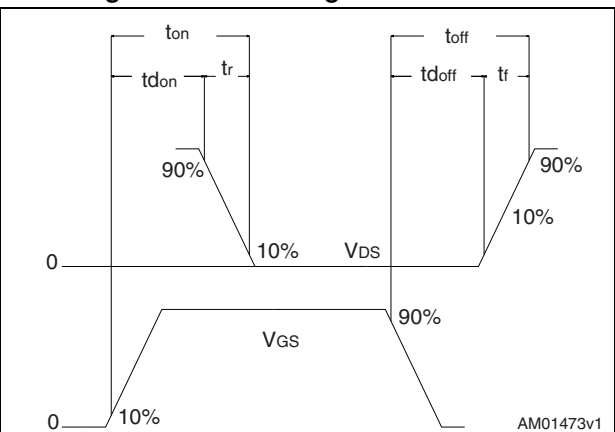

Figure 22. Switching time waveform



4 Package mechanical data

In order to meet environmental requirements, ST offers these devices in different grades of ECOPACK® packages, depending on their level of environmental compliance. ECOPACK® specifications, grade definitions and product status are available at: www.st.com. ECOPACK® is an ST trademark.

Figure 23. D²PAK (TO-263) drawing

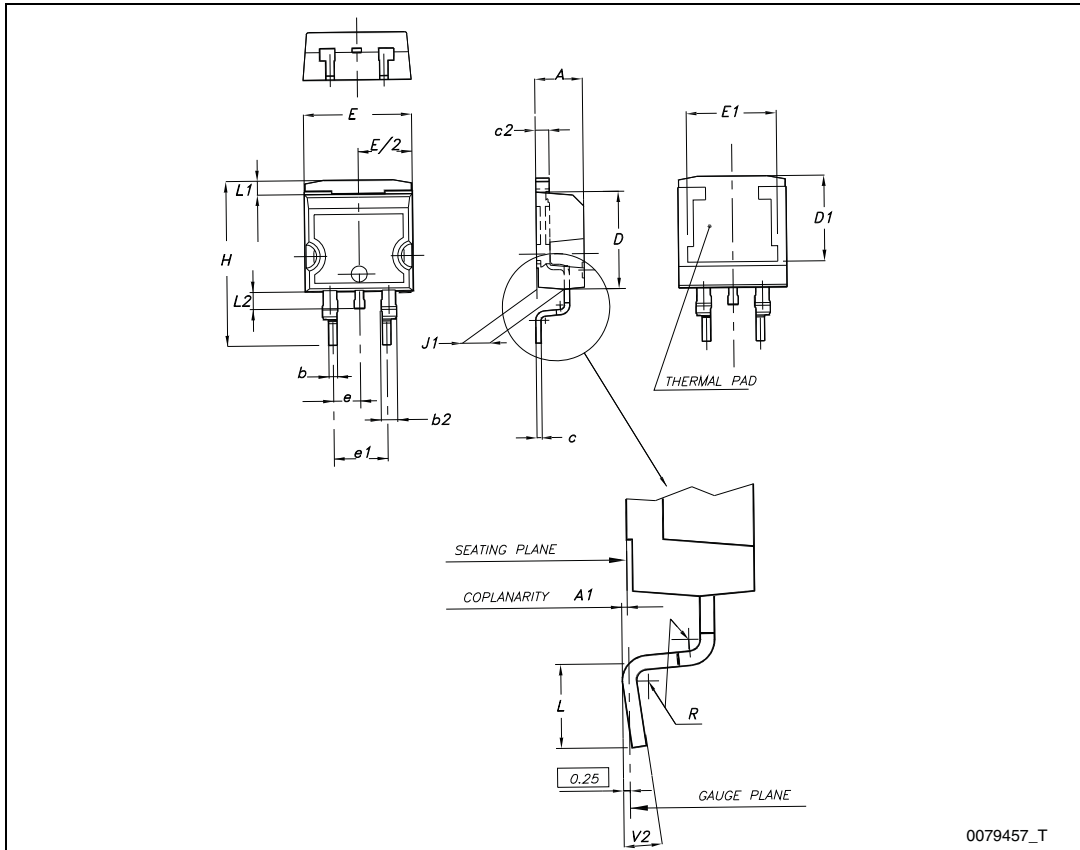
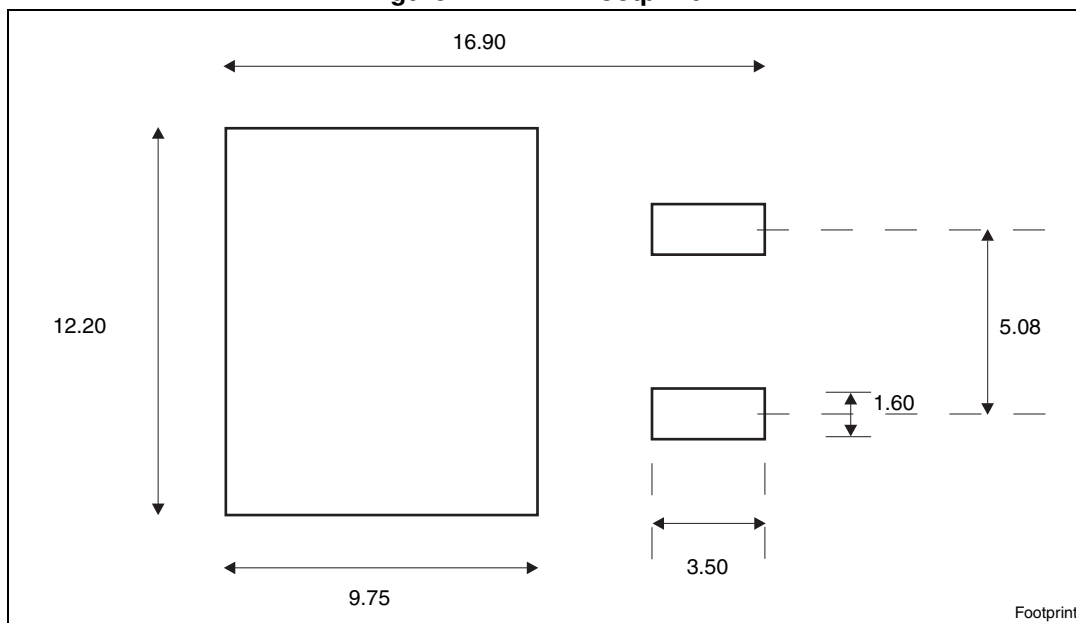

Figure 24. D²PAK footprint^(a)



a. All dimension are in millimeters

Table 9. DPAK (TO-252) mechanical data

Dim.	mm		
	Min.	Typ.	Max.
A	2.20		2.40
A1	0.90		1.10
A2	0.03		0.23
b	0.64		0.90
b4	5.20		5.40
c	0.45		0.60
c2	0.48		0.60
D	6.00		6.20
D1		5.10	
E	6.40		6.60
E1		4.70	
e		2.28	
e1	4.40		4.60
H	9.35		10.10
L	1.00		1.50
(L1)		2.80	
L2		0.80	
L4	0.60		1.00
R		0.20	
V2	0°		8°

Figure 25. DPAK (TO-252) drawing

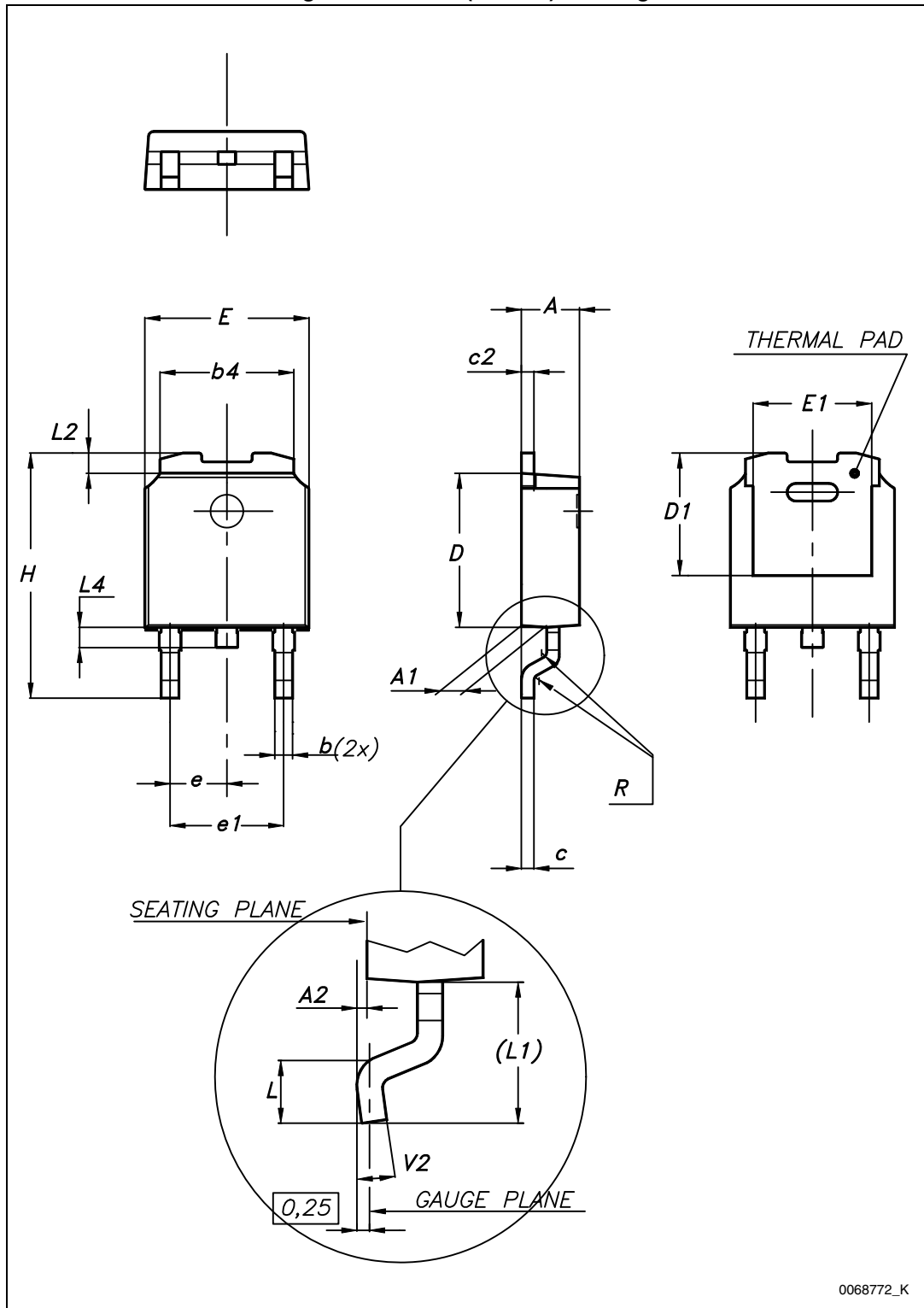
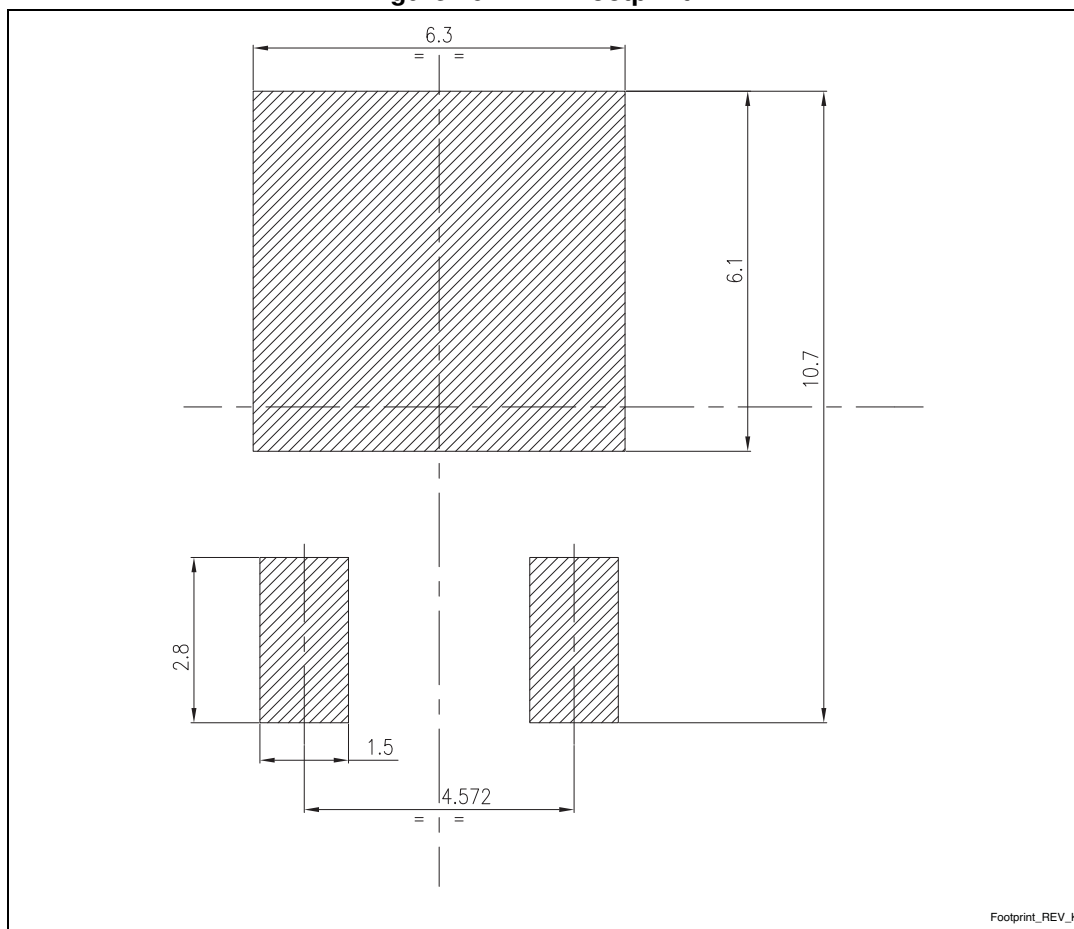

Figure 26. DPAK footprint (b)



b. All dimensions are in millimeters

Table 10. TO-220FP mechanical data

Dim.	mm		
	Min.	Typ.	Max.
A	4.4		4.6
B	2.5		2.7
D	2.5		2.75
E	0.45		0.7
F	0.75		1
F1	1.15		1.70
F2	1.15		1.70
G	4.95		5.2
G1	2.4		2.7
H	10		10.4
L2		16	
L3	28.6		30.6
L4	9.8		10.6
L5	2.9		3.6
L6	15.9		16.4
L7	9		9.3
Dia	3		3.2

Figure 27. TO-220FP drawing

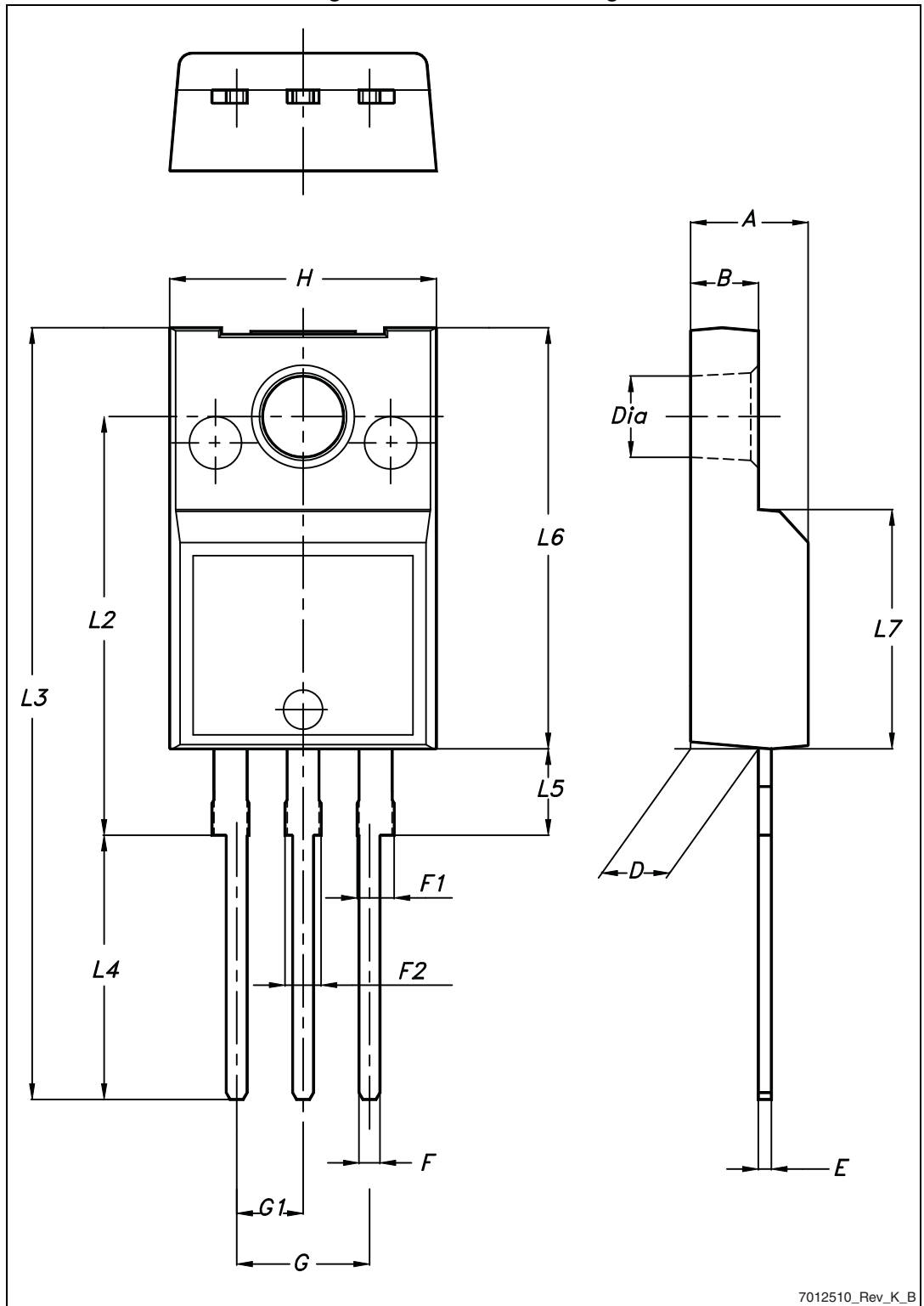

7012510_Rev_K_B

Table 11. TO-220 type A mechanical data

Dim.	mm		
	Min.	Typ.	Max.
A	4.40		4.60
b	0.61		0.88
b1	1.14		1.70
c	0.48		0.70
D	15.25		15.75
D1		1.27	
E	10		10.40
e	2.40		2.70
e1	4.95		5.15
F	1.23		1.32
H1	6.20		6.60
J1	2.40		2.72
L	13		14
L1	3.50		3.93
L20		16.40	
L30		28.90	
ØP	3.75		3.85
Q	2.65		2.95

Figure 28. TO-220 type A drawing

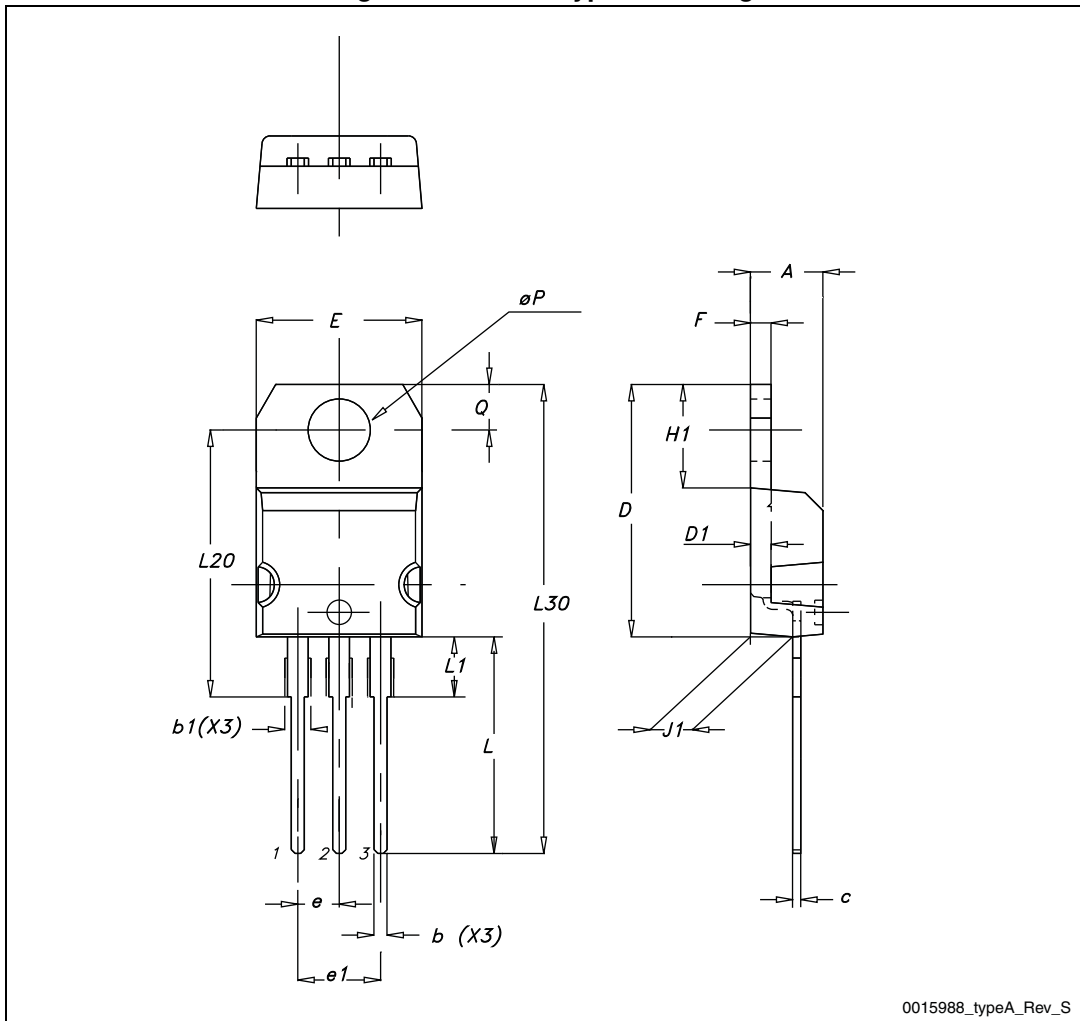

5 Packaging mechanical data

Table 12. D²PAK (TO-263) tape and reel mechanical data

Tape			Reel		
Dim.	mm		Dim.	mm	
	Min.	Max.		Min.	Max.
A0	10.5	10.7	A		330
B0	15.7	15.9	B	1.5	
D	1.5	1.6	C	12.8	13.2
D1	1.59	1.61	D	20.2	
E	1.65	1.85	G	24.4	26.4
F	11.4	11.6	N	100	
K0	4.8	5.0	T		30.4
P0	3.9	4.1			
P1	11.9	12.1		Base qty	1000
P2	1.9	2.1		Bulk qty	1000
R	50				
T	0.25	0.35			
W	23.7	24.3			

Table 13. DPAK (TO-252) tape and reel mechanical data

Tape			Reel		
Dim.	mm		Dim.	mm	
	Min.	Max.		Min.	Max.
A0	6.8	7	A		330
B0	10.4	10.6	B	1.5	
B1		12.1	C	12.8	13.2
D	1.5	1.6	D	20.2	
D1	1.5		G	16.4	18.4
E	1.65	1.85	N	50	
F	7.4	7.6	T		22.4
K0	2.55	2.75			
P0	3.9	4.1		Base qty.	2500
P1	7.9	8.1		Bulk qty.	2500

Table 13. DPAK (TO-252) tape and reel mechanical data (continued)

Tape			Reel		
Dim.	mm		Dim.	mm	
	Min.	Max.		Min.	Max.
P2	1.9	2.1			
R	40				
T	0.25	0.35			
W	15.7	16.3			

Figure 29. Tape

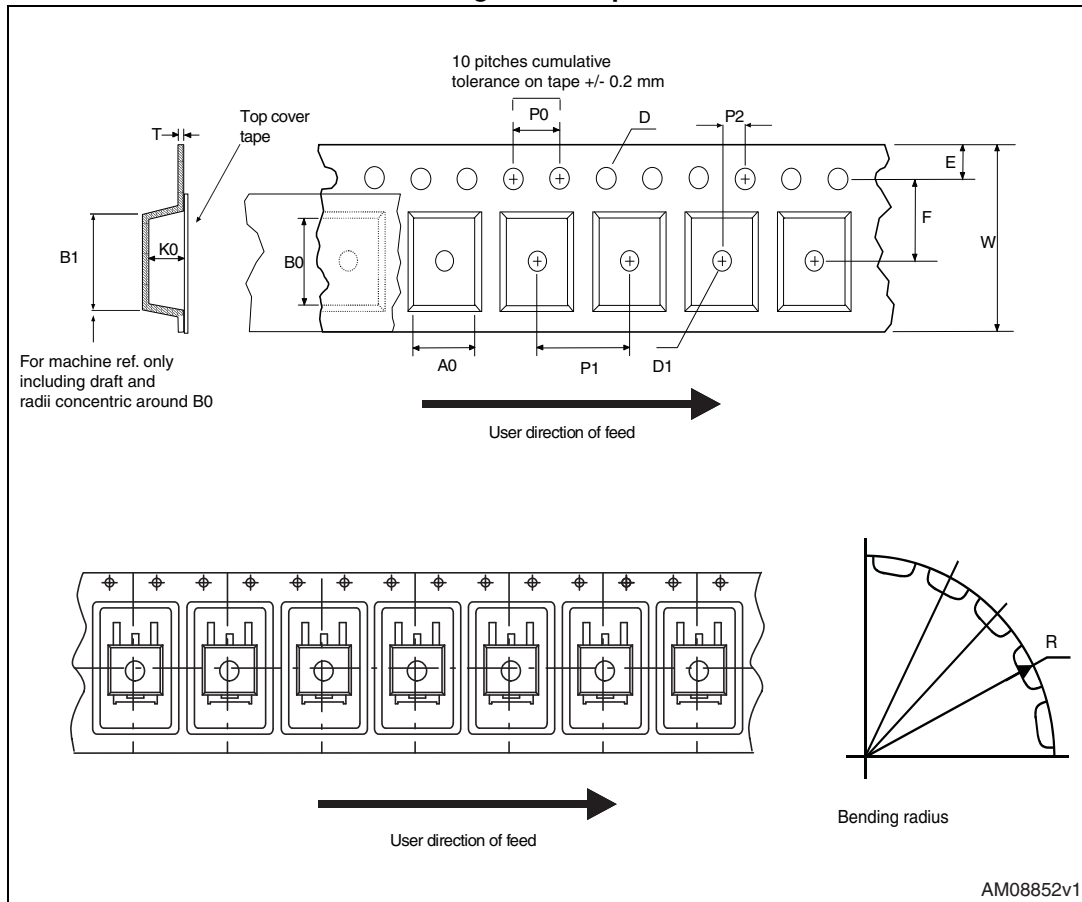
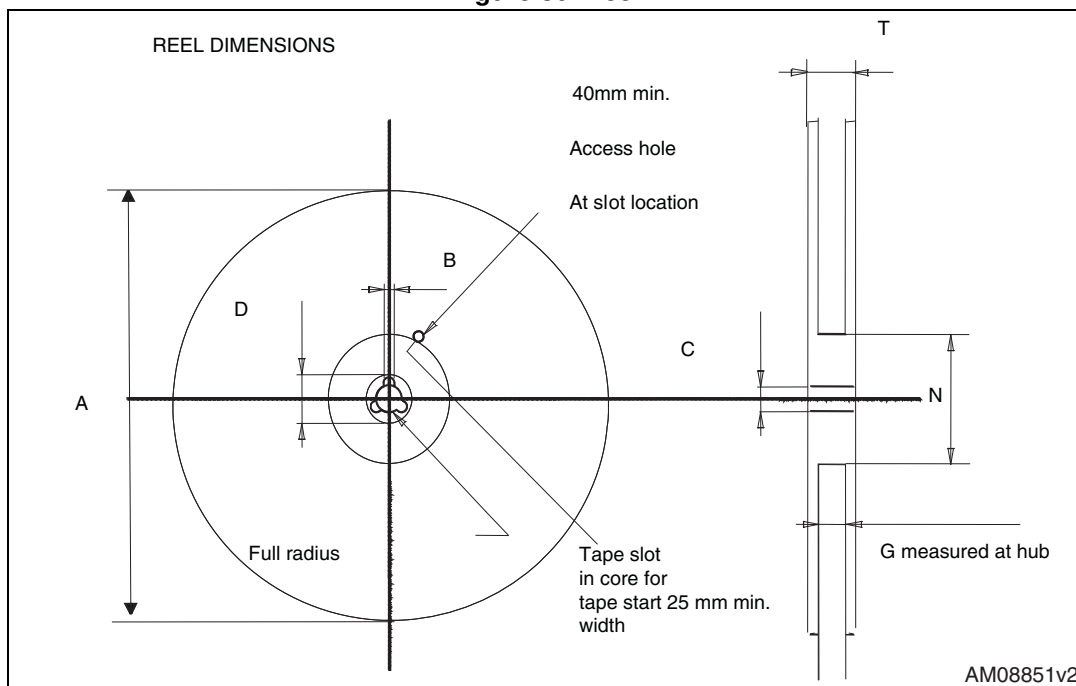

Figure 30. Reel



6 Revision history

Table 14. Document revision history

Date	Revision	Changes
05-Oct-2012	1	First release.
07-Feb-2013	2	<ul style="list-style-type: none"> – Inserted device in TO-220FP. – Updated title and features on the cover page, Table 1: Device summary, Table 2: Absolute maximum ratings, Table 3: Thermal resistance and Table 5: On/off states accordingly. – Updated Table 6: Dynamic, Table 7: Switching times, Table 8: Source drain diode and Section 4: Package mechanical data. – Added Section 5: Packaging mechanical data.
29-Apr-2013	3	<ul style="list-style-type: none"> – Modified: the entire typical values in Table 6, t_f typical value in Table 7, V_{SD} and typical values for t_{rr}, q_{rr}, I_{RRM} – Inserted: Table 4: Avalanche characteristics and Section 2.1: Electrical characteristics (curves) – Minor text changes
25-Nov-2013	4	<ul style="list-style-type: none"> – Inserted device in D²PAK. – Updated title and features on the cover page, Table 1: Device summary, Table 2: Absolute maximum ratings, Table 3: Thermal resistance and Table 5: On/off states accordingly. – Updated Table 6: Dynamic, Section 4: Package mechanical data and Section 5: Packaging mechanical data.

Please Read Carefully:

Information in this document is provided solely in connection with ST products. STMicroelectronics NV and its subsidiaries ("ST") reserve the right to make changes, corrections, modifications or improvements, to this document, and the products and services described herein at any time, without notice.

All ST products are sold pursuant to ST's terms and conditions of sale.

Purchasers are solely responsible for the choice, selection and use of the ST products and services described herein, and ST assumes no liability whatsoever relating to the choice, selection or use of the ST products and services described herein.

No license, express or implied, by estoppel or otherwise, to any intellectual property rights is granted under this document. If any part of this document refers to any third party products or services it shall not be deemed a license grant by ST for the use of such third party products or services, or any intellectual property contained therein or considered as a warranty covering the use in any manner whatsoever of such third party products or services or any intellectual property contained therein.

UNLESS OTHERWISE SET FORTH IN ST'S TERMS AND CONDITIONS OF SALE ST DISCLAIMS ANY EXPRESS OR IMPLIED WARRANTY WITH RESPECT TO THE USE AND/OR SALE OF ST PRODUCTS INCLUDING WITHOUT LIMITATION IMPLIED WARRANTIES OF MERCHANTABILITY, FITNESS FOR A PARTICULAR PURPOSE (AND THEIR EQUIVALENTS UNDER THE LAWS OF ANY JURISDICTION), OR INFRINGEMENT OF ANY PATENT, COPYRIGHT OR OTHER INTELLECTUAL PROPERTY RIGHT.

ST PRODUCTS ARE NOT DESIGNED OR AUTHORIZED FOR USE IN: (A) SAFETY CRITICAL APPLICATIONS SUCH AS LIFE SUPPORTING, ACTIVE IMPLANTED DEVICES OR SYSTEMS WITH PRODUCT FUNCTIONAL SAFETY REQUIREMENTS; (B) AERONAUTIC APPLICATIONS; (C) AUTOMOTIVE APPLICATIONS OR ENVIRONMENTS, AND/OR (D) AEROSPACE APPLICATIONS OR ENVIRONMENTS. WHERE ST PRODUCTS ARE NOT DESIGNED FOR SUCH USE, THE PURCHASER SHALL USE PRODUCTS AT PURCHASER'S SOLE RISK, EVEN IF ST HAS BEEN INFORMED IN WRITING OF SUCH USAGE, UNLESS A PRODUCT IS EXPRESSLY DESIGNATED BY ST AS BEING INTENDED FOR "AUTOMOTIVE, AUTOMOTIVE SAFETY OR MEDICAL" INDUSTRY DOMAINS ACCORDING TO ST PRODUCT DESIGN SPECIFICATIONS. PRODUCTS FORMALLY ESCC, QML OR JAN QUALIFIED ARE DEEMED SUITABLE FOR USE IN AEROSPACE BY THE CORRESPONDING GOVERNMENTAL AGENCY.

Resale of ST products with provisions different from the statements and/or technical features set forth in this document shall immediately void any warranty granted by ST for the ST product or service described herein and shall not create or extend in any manner whatsoever, any liability of ST.

ST and the ST logo are trademarks or registered trademarks of ST in various countries.

Information in this document supersedes and replaces all information previously supplied.

The ST logo is a registered trademark of STMicroelectronics. All other names are the property of their respective owners.

© 2013 STMicroelectronics - All rights reserved

STMicroelectronics group of companies

Australia - Belgium - Brazil - Canada - China - Czech Republic - Finland - France - Germany - Hong Kong - India - Israel - Italy - Japan - Malaysia - Malta - Morocco - Philippines - Singapore - Spain - Sweden - Switzerland - United Kingdom - United States of America

www.st.com