



Chipsmall Limited consists of a professional team with an average of over 10 year of expertise in the distribution of electronic components. Based in Hongkong, we have already established firm and mutual-benefit business relationships with customers from,Europe,America and south Asia,supplying obsolete and hard-to-find components to meet their specific needs.

With the principle of “Quality Parts,Customers Priority,Honest Operation,and Considerate Service”,our business mainly focus on the distribution of electronic components. Line cards we deal with include Microchip,ALPS,ROHM,Xilinx,Pulse,ON,Everlight and Freescale. Main products comprise IC,Modules,Potentiometer,IC Socket,Relay,Connector.Our parts cover such applications as commercial,industrial, and automotives areas.

We are looking forward to setting up business relationship with you and hope to provide you with the best service and solution. Let us make a better world for our industry!



Contact us

Tel: +86-755-8981 8866 Fax: +86-755-8427 6832

Email & Skype: info@chipsmall.com Web: www.chipsmall.com

Address: A1208, Overseas Decoration Building, #122 Zhenhua RD., Futian, Shenzhen, China





STD20NF20 STF20NF20, STP20NF20

N-channel 200 V, 0.10 Ω , 18 A DPAK, TO-220, TO-220FP
low gate charge STripFET™ Power MOSFET

Features

| Type | V _{DSS} | R _{DS(on)} | I _D | P _W |
|-----------|------------------|---------------------|----------------|----------------|
| STD20NF20 | 200 V | < 0.125 Ω | 18 A | 110 W |
| STF20NF20 | 200 V | < 0.125 Ω | 18 A | 30 W |
| STP20NF20 | 200 V | < 0.125 Ω | 18 A | 110 W |

- Exceptional dv/dt capability
- Low gate charge
- 100% avalanche tested

Application

- Switching applications

Description

This Power MOSFET series realized with STMicroelectronics unique STripFET™ process has specifically been designed to minimize input capacitance and gate charge. It is therefore suitable as primary switch in advanced high-efficiency isolated DC-DC converters.

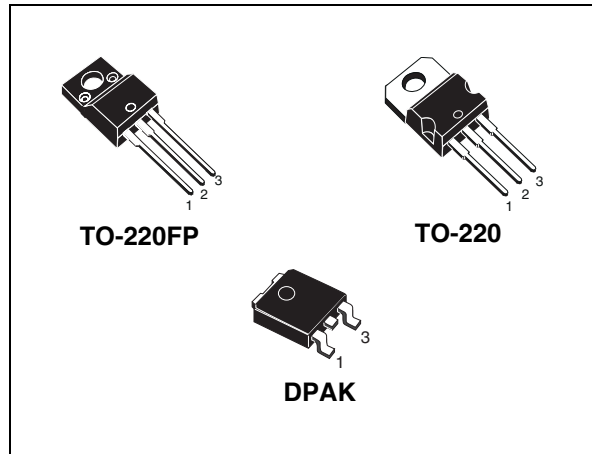

Figure 1. Internal schematic diagram

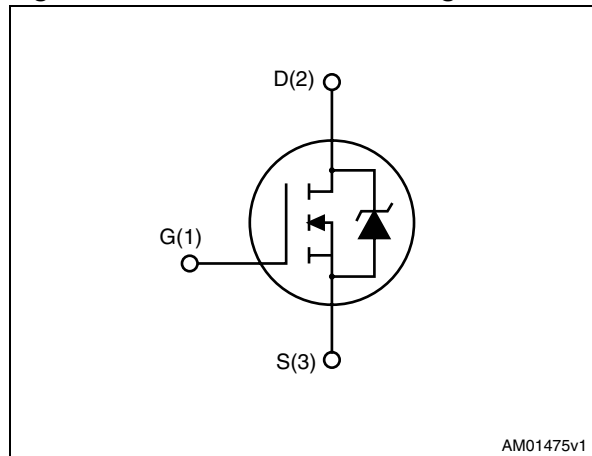

Table 1. Device summary

| Order codes | Marking | Package | Packaging |
|-------------|---------|----------|---------------|
| STD20NF20 | 20NF20 | DPAK | Tape and reel |
| STF20NF20 | 20NF20 | TO-220FP | Tube |
| STP20NF20 | 20NF20 | TO-220 | Tube |

Contents

| | | |
|----------|---|-----------|
| 1 | Electrical ratings | 3 |
| 2 | Electrical characteristics | 4 |
| 2.1 | Electrical characteristics (curves) | 6 |
| 3 | Test circuits | 9 |
| 4 | Package mechanical data | 10 |
| 5 | Packaging mechanical data | 13 |
| 6 | Revision history | 14 |

1 Electrical ratings

Table 2. Absolute maximum ratings

| Symbol | Parameter | Value | | Unit |
|----------------|---|--------------|----------|---------------------|
| | | TO-220, DPAK | TO-220FP | |
| V_{DS} | Drain-source voltage ($V_{GS} = 0$) | 200 | | V |
| V_{GS} | Gate- source voltage | ± 20 | | V |
| I_D | Drain current (continuous) at $T_C = 25\text{ }^\circ\text{C}$ | 18 | | A |
| I_D | Drain current (continuous) at $T_C = 100\text{ }^\circ\text{C}$ | 11 | | A |
| $I_{DM}^{(1)}$ | Drain current (pulsed) | 72 | | A |
| P_{TOT} | Total dissipation at $T_C = 25\text{ }^\circ\text{C}$ | 110 | 30 | W |
| | Derating factor | 0.72 | 0.2 | W/ $^\circ\text{C}$ |
| $dv/dt^{(2)}$ | Peak diode recovery voltage slope | 15 | | V/ns |
| V_{ISO} | Insulation withstand voltage (RMS) from all three leads to external heat sink ($t = 1\text{ s}$; $T_C = 25\text{ }^\circ\text{C}$) | 2500 | | V |
| T_{stg} | Storage temperature | -55 to 175 | | $^\circ\text{C}$ |
| T_j | Max. operating junction temperature | | | |

1. Pulse width limited by safe operating area
2. $I_{SD} \leq 18\text{ A}$, $di/dt \leq 400\text{ A}/\mu\text{s}$, $V_{DD} \leq V_{(BR)DSS}$

Table 3. Thermal data

| Symbol | Parameter | TO-220 | DPAK | TO-220FP | Unit |
|-----------|--|--------|-------------------|----------|---------------------------|
| Rthj-case | Thermal resistance junction-case max | 1.38 | 1.38 | 5 | $^\circ\text{C}/\text{W}$ |
| Rthj-amb | Thermal resistance junction-ambient max | 62.5 | 50 ⁽¹⁾ | 62.5 | $^\circ\text{C}/\text{W}$ |
| T_I | Maximum lead temperature for soldering purpose | | | 300 | $^\circ\text{C}$ |

1. When mounted on 1inch² FR-4, 2 Oz copper board.

Table 4. Avalanche characteristics

| Symbol | Parameter | Max value | Unit |
|----------|--|-----------|------|
| I_{AR} | Avalanche current, repetitive or not-repetitive (pulse width limited by T_j max) | 18 | A |
| E_{AS} | Single pulse avalanche energy (starting $T_j = 25\text{ }^\circ\text{C}$, $I_D = I_{AR}$, $V_{DD} = 50\text{ V}$) | 110 | mJ |

2 Electrical characteristics

($T_{CASE}=25^{\circ}\text{C}$ unless otherwise specified)

Table 5. On/off states

| Symbol | Parameter | Test conditions | Min. | Typ. | Max. | Unit |
|---------------|--|---|------|------|-----------|--------------------------------|
| $V_{(BR)DSS}$ | Drain-source breakdown voltage | $I_D = 1 \text{ mA}, V_{GS} = 0$ | 200 | | | V |
| I_{DSS} | Zero gate voltage drain current ($V_{GS} = 0$) | $V_{DS} = \text{Max rating}$ $V_{DS} = \text{Max rating}, T_C = 125^{\circ}\text{C}$ | | | 1 10 | μA μA |
| I_{GSS} | Gate-body leakage current ($V_{DS} = 0$) | $V_{GS} = \pm 20 \text{ V}$ | | | ± 100 | nA |
| $V_{GS(th)}$ | Gate threshold voltage | $V_{DS} = V_{GS}, I_D = 250 \mu\text{A}$ | 2 | 3 | 4 | V |
| $R_{DS(on)}$ | Static drain-source on resistance | $V_{GS} = 10 \text{ V}, I_D = 10 \text{ A}$ | | 0.10 | 0.125 | Ω |

Table 6. Dynamic

| Symbol | Parameter | Test conditions | Min. | Typ. | Max. | Unit |
|---|---|--|------|----------------------|------|----------------------|
| $g_{fs}^{(1)}$ | Forward transconductance | $V_{DS} = 25 \text{ V}, I_D = 10 \text{ A}$ | - | 13 | | S |
| C_{iss} C_{oss} C_{rss} | Input capacitance Output capacitance Reverse transfer capacitance | $V_{DS} = 25 \text{ V}, f = 1 \text{ MHz},$ $V_{GS} = 0$ | - | 940 197 30 | | pF pF pF |
| $t_{d(on)}$ t_r $t_{d(off)}$ t_f | Turn-on delay time Rise time Turn-off delay time Fall time | $V_{DD} = 100 \text{ V}, I_D = 10 \text{ A},$ $R_G = 4.7 \Omega, V_{GS} = 10 \text{ V}$ <i>(see Figure 15)</i> | - | 15 30 40 10 | | ns ns ns ns |
| Q_g Q_{gs} Q_{gd} | Total gate charge Gate-source charge Gate-drain charge | $V_{DD} = 160 \text{ V}, I_D = 20 \text{ A},$ $V_{GS} = 10 \text{ V}$ <i>(see Figure 16)</i> | - | 28 5.6 14.5 | 39 | nC nC nC |

1. Pulsed: Pulse duration = 300 μs , duty cycle 1.5%.

Table 7. Source drain diode

| Symbol | Parameter | Test conditions | Min. | Typ. | Max. | Unit |
|-----------------------------------|--|--|------|---------------------|----------|---------------|
| I_{SD} $I_{SDM}^{(1)}$ | Source-drain current Source-drain current (pulsed) | | - | | 18 72 | A A |
| $V_{SD}^{(2)}$ | Forward on voltage | $I_{SD} = 20\text{ A}$, $V_{GS} = 0$ | - | | 1.6 | V |
| t_{rr} Q_{rr} I_{RRM} | Reverse recovery time Reverse recovery charge Reverse recovery current | $I_{SD} = 20\text{ A}$, $di/dt = 100\text{A}/\mu\text{s}$ $V_{DD} = 50\text{ V}$ (see Figure 20) | - | 155 775 10 | | ns nC A |
| t_{rr} Q_{rr} I_{RRM} | Reverse recovery time Reverse recovery charge Reverse recovery current | $I_{SD} = 20\text{ A}$, $di/dt = 100\text{ A}/\mu\text{s}$ $V_{DD} = 50\text{ V}$, $T_j = 150\text{ }^\circ\text{C}$ (see Figure 20) | - | 183 1061 11.6 | | ns nC A |

1. Pulse width limited by safe operating area.
2. Pulsed: Pulse duration = 300 μs , duty cycle 1.5%.

2.1 Electrical characteristics (curves)

Figure 2. Safe operating area for TO-220, DPAK

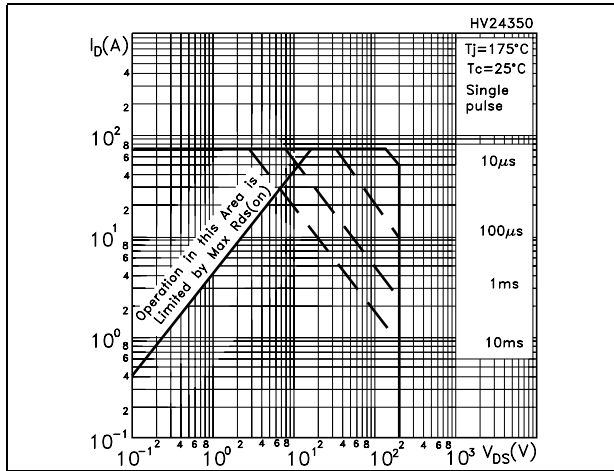

Figure 3. Thermal impedance area for TO-220, DPAK

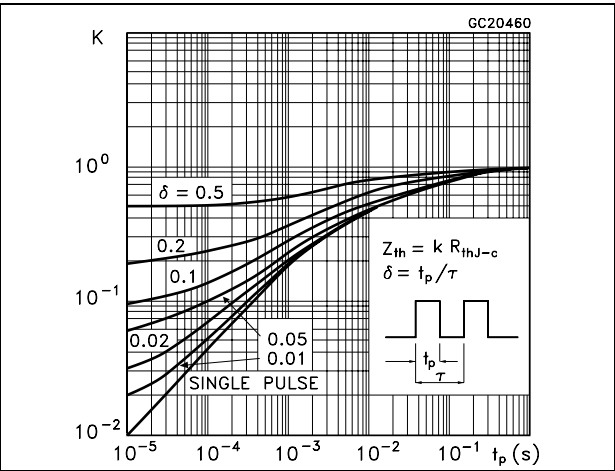

Figure 4. Safe operating area for TO-220FP

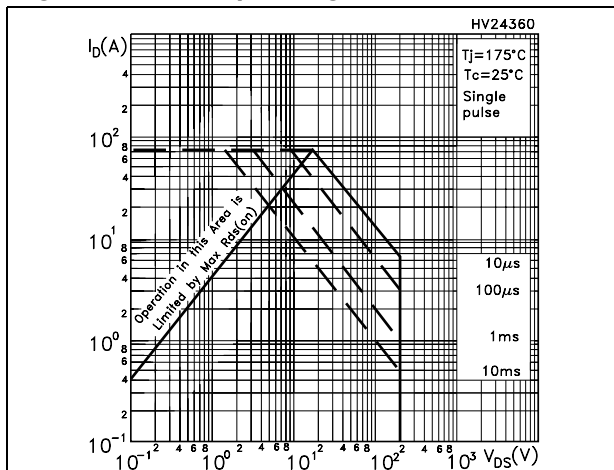

Figure 5. Thermal impedance for TO-220FP

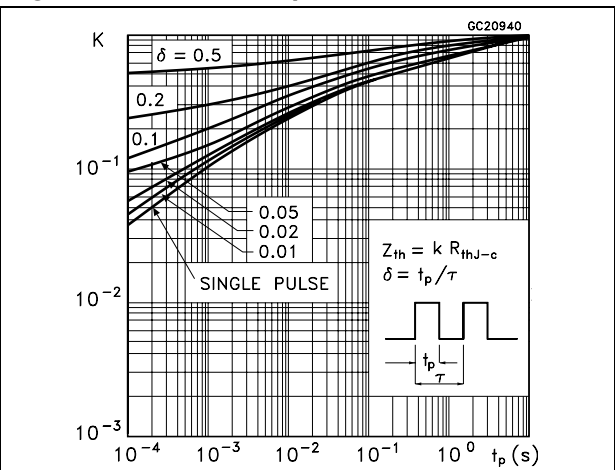

Figure 6. Output characteristics

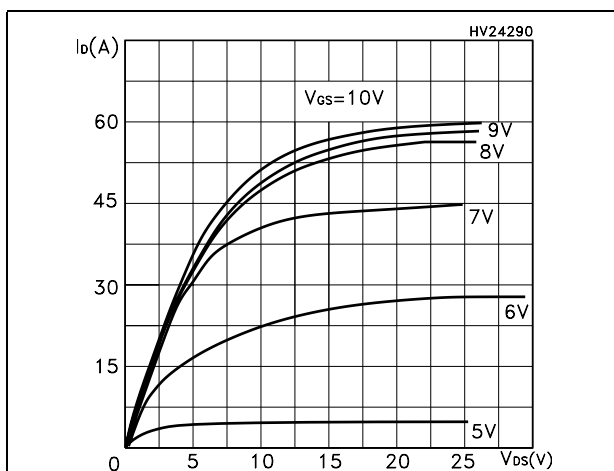

Figure 7. Transfer characteristics

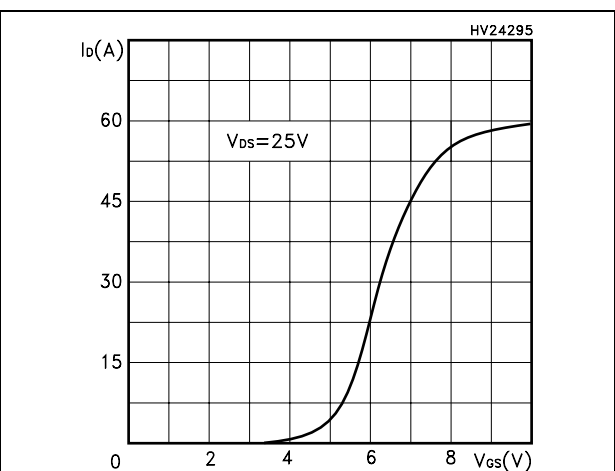

Figure 8. Transconductance

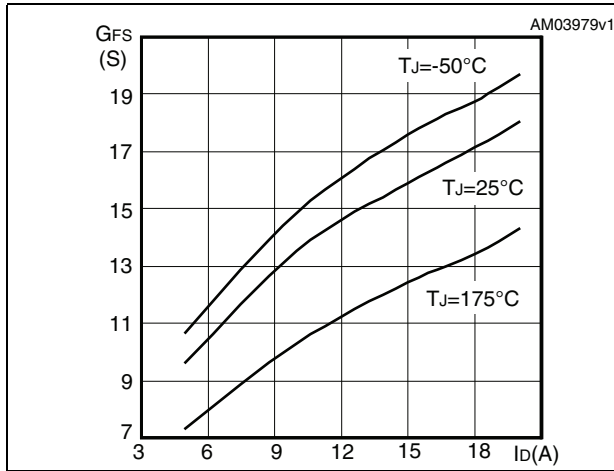

Figure 9. Static drain-source on resistance

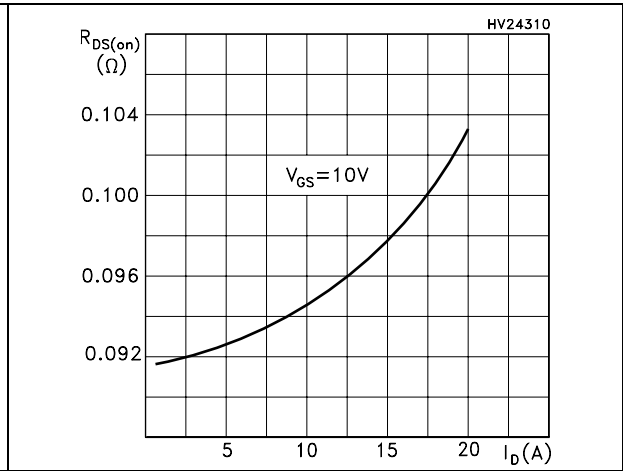

Figure 10. Gate charge vs gate-source voltage

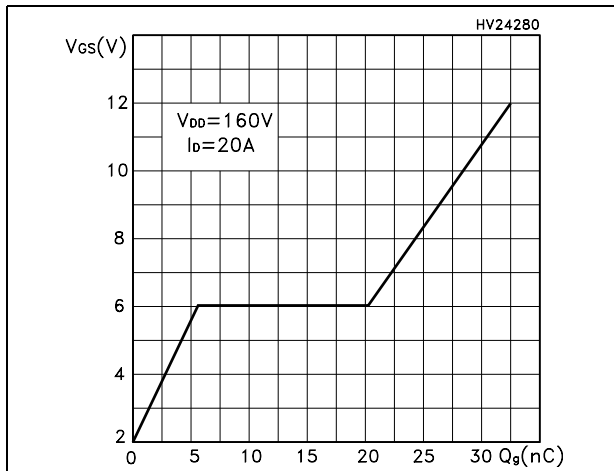

Figure 11. Capacitance variations

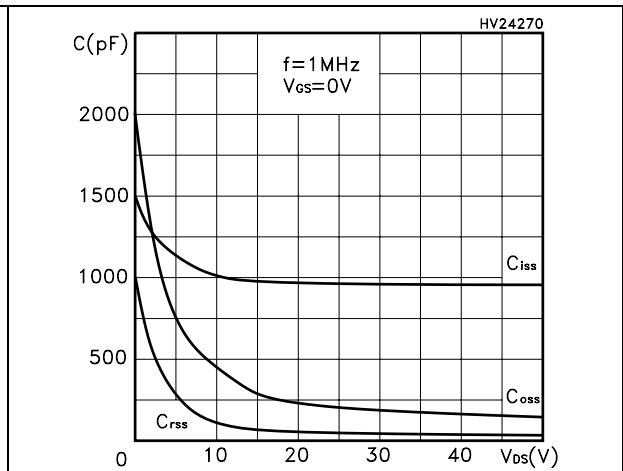

Figure 12. Normalized gate threshold voltage vs temperature

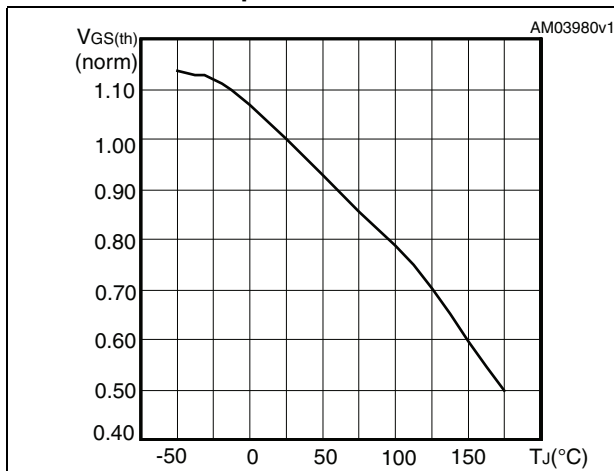

Figure 13. Normalized on resistance vs temperature

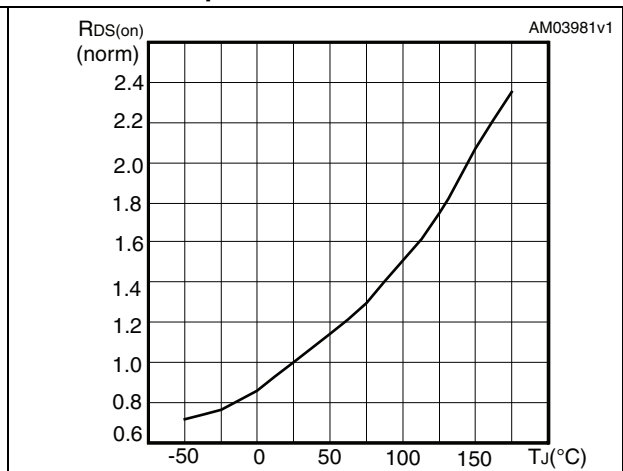
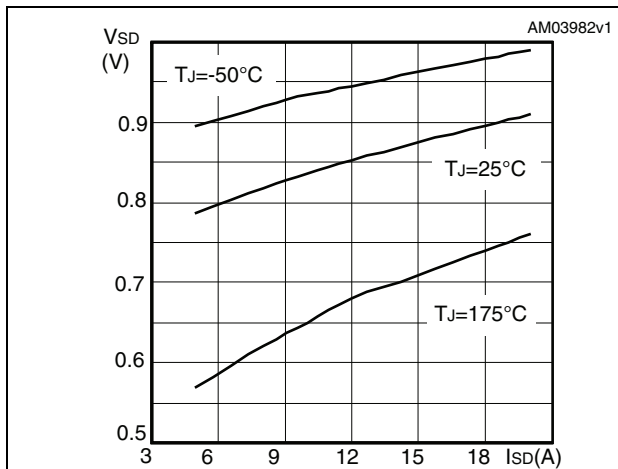

Figure 14. Source-drain diode forward characteristics



3 Test circuits

Figure 15. Switching times test circuit for resistive load

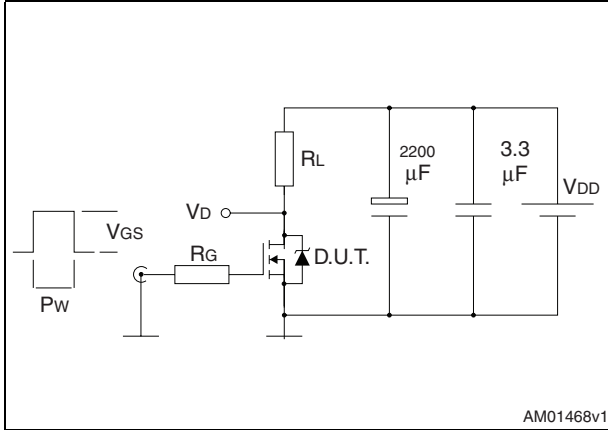

Figure 16. Gate charge test circuit

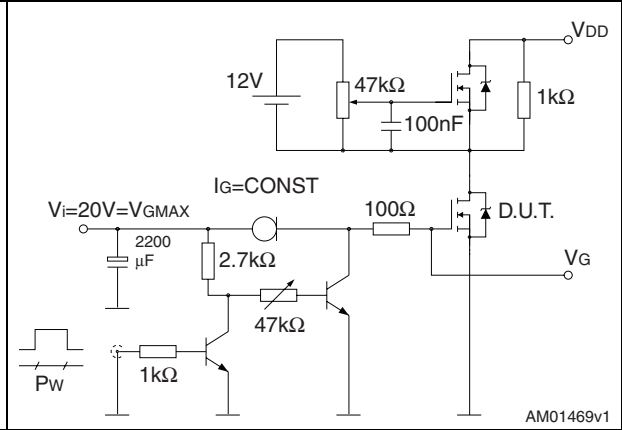

Figure 17. Test circuit for inductive load switching and diode recovery times

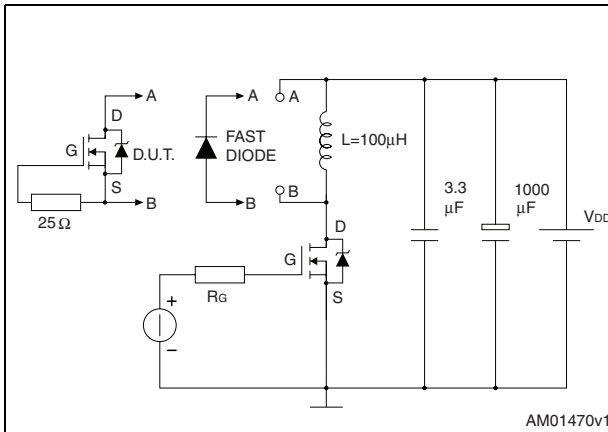

Figure 18. Unclamped inductive load test circuit

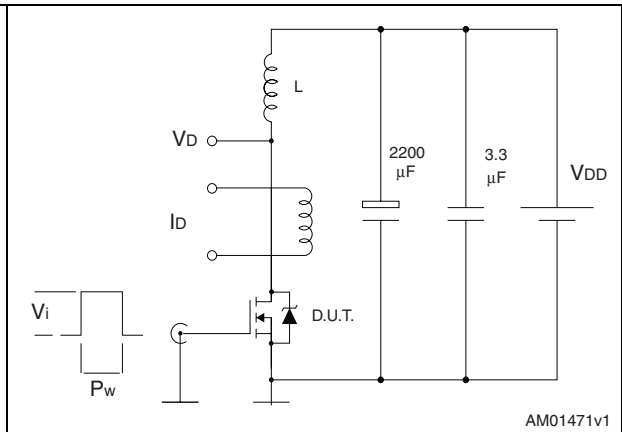

Figure 19. Unclamped inductive waveform

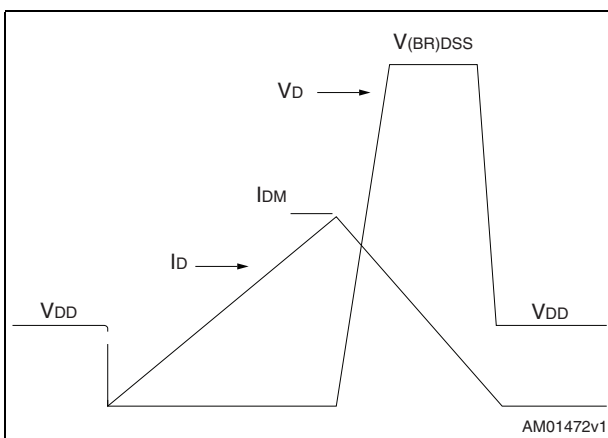
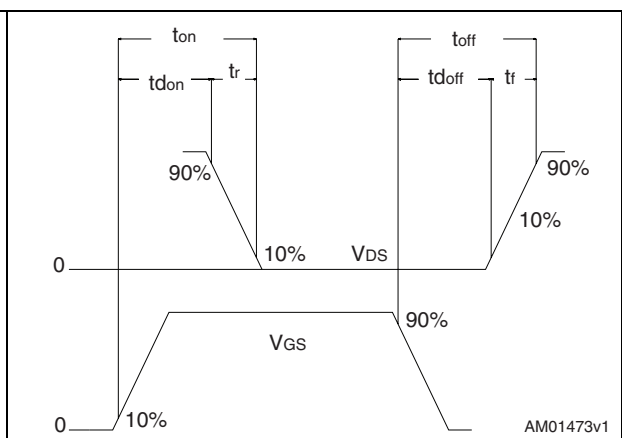

Figure 20. Switching time waveform



4 Package mechanical data

In order to meet environmental requirements, ST offers these devices in different grades of ECOPACK[®] packages, depending on their level of environmental compliance. ECOPACK[®] specifications, grade definitions and product status are available at: www.st.com. ECOPACK is an ST trademark.

TO-220 type A mechanical data

| Dim | mm | | |
|-----|-------|-------|-------|
| | Min | Typ | Max |
| A | 4.40 | | 4.60 |
| b | 0.61 | | 0.88 |
| b1 | 1.14 | | 1.70 |
| c | 0.48 | | 0.70 |
| D | 15.25 | | 15.75 |
| D1 | | 1.27 | |
| E | 10 | | 10.40 |
| e | 2.40 | | 2.70 |
| e1 | 4.95 | | 5.15 |
| F | 1.23 | | 1.32 |
| H1 | 6.20 | | 6.60 |
| J1 | 2.40 | | 2.72 |
| L | 13 | | 14 |
| L1 | 3.50 | | 3.93 |
| L20 | | 16.40 | |
| L30 | | 28.90 | |
| ∅P | 3.75 | | 3.85 |
| Q | 2.65 | | 2.95 |

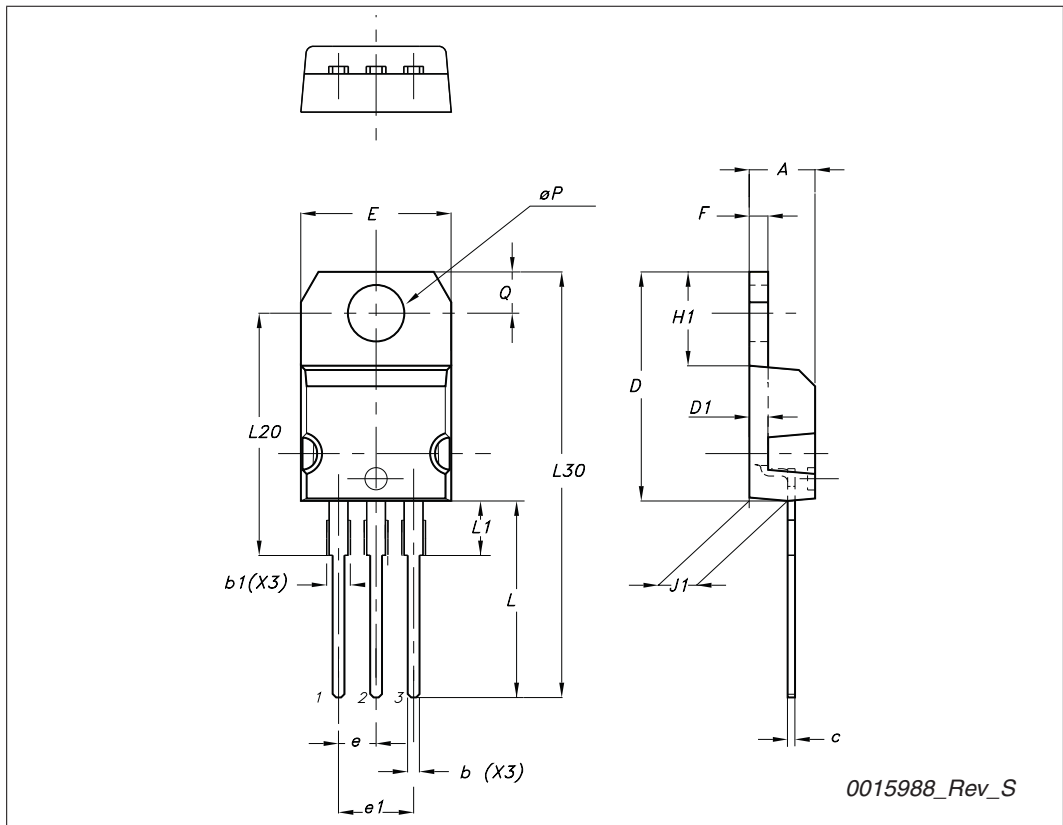

TO-252 (DPAK) mechanical data

| DIM. | mm. | | |
|------|------|------|-------|
| | min. | typ | max. |
| A | 2.20 | | 2.40 |
| A1 | 0.90 | | 1.10 |
| A2 | 0.03 | | 0.23 |
| b | 0.64 | | 0.90 |
| b4 | 5.20 | | 5.40 |
| c | 0.45 | | 0.60 |
| c2 | 0.48 | | 0.60 |
| D | 6.00 | | 6.20 |
| D1 | | 5.10 | |
| E | 6.40 | | 6.60 |
| E1 | | 4.70 | |
| e | | 2.28 | |
| e1 | 4.40 | | 4.60 |
| H | 9.35 | | 10.10 |
| L | 1 | | |
| L1 | | 2.80 | |
| L2 | | 0.80 | |
| L4 | 0.60 | | 1 |
| R | | 0.20 | |
| V2 | 0° | | 8° |

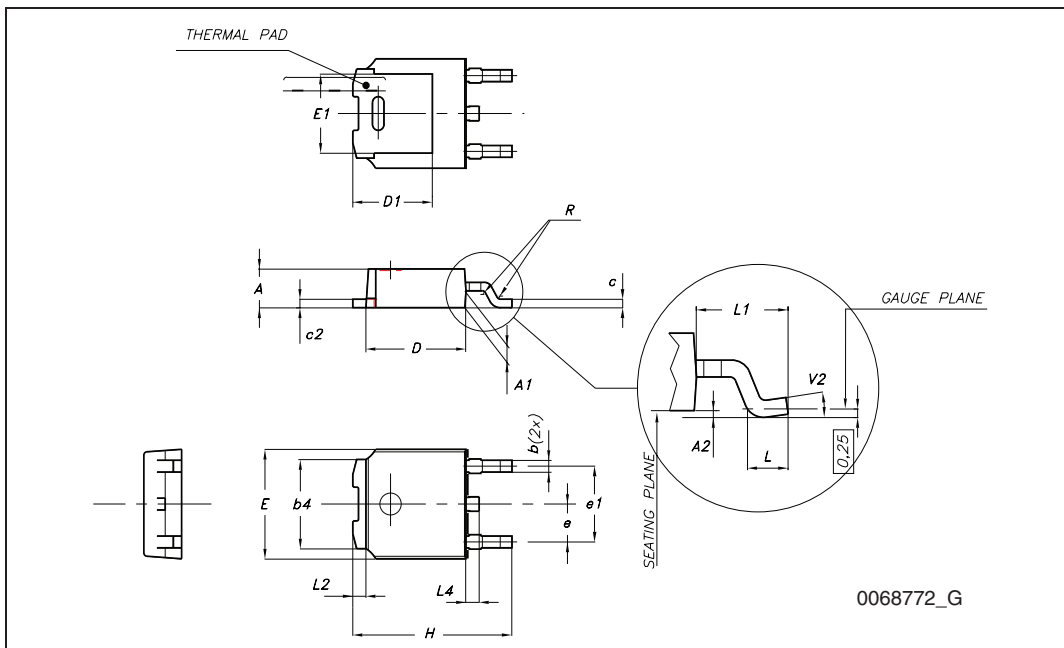

5 Packaging mechanical data

DPAK FOOTPRINT

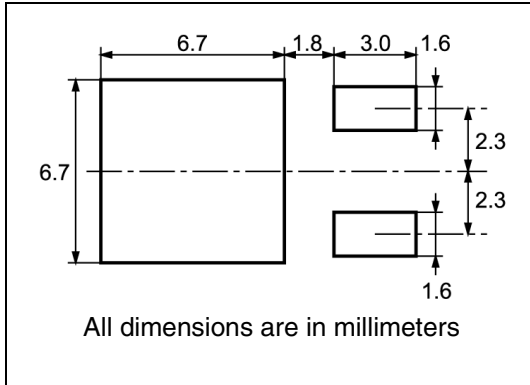

TAPE AND REEL SHIPMENT

40 mm min. Access hole at slot location

Full radius

Tape slot in core for tape start 2.5mm min. width

REEL MECHANICAL DATA

| DIM. | mm | | inch | |
|------|------|------|-------|--------|
| | MIN. | MAX. | MIN. | MAX. |
| A | | 330 | | 12.992 |
| B | 1.5 | | 0.059 | |
| C | 12.8 | 13.2 | 0.504 | 0.520 |
| D | 20.2 | | 0.795 | |
| G | 16.4 | 18.4 | 0.645 | 0.724 |
| N | 50 | | 1.968 | |
| T | | 22.4 | | 0.881 |

TAPE MECHANICAL DATA

| DIM. | mm | | inch | |
|------|------|------|-------|-------|
| | MIN. | MAX. | MIN. | MAX. |
| A0 | 6.8 | 7 | 0.267 | 0.275 |
| B0 | 10.4 | 10.6 | 0.409 | 0.417 |
| B1 | | 12.1 | | 0.476 |
| D | 1.5 | 1.6 | 0.059 | 0.063 |
| D1 | 1.5 | | 0.059 | |
| E | 1.65 | 1.85 | 0.065 | 0.073 |
| F | 7.4 | 7.6 | 0.291 | 0.299 |
| K0 | 2.55 | 2.75 | 0.100 | 0.108 |
| P0 | 3.9 | 4.1 | 0.153 | 0.161 |
| P1 | 7.9 | 8.1 | 0.311 | 0.319 |
| P2 | 1.9 | 2.1 | 0.075 | 0.082 |
| R | 40 | | 1.574 | |
| W | 15.7 | 16.3 | 0.618 | 0.641 |

BASE QTY

| |
|------|
| 2500 |
|------|

BULK QTY

| |
|------|
| 2500 |
|------|

TOP COVER TAPE

Center line of cavity

User Direction of Feed

Bending radius R min.

For machine ref. only including draft and radii concentric around B0

TRL

FEED DIRECTION

10 pitches cumulative tolerance on tape +/- 0.2 mm

6 Revision history

Table 8. Revision history

| Date | Revision | Changes |
|-------------|----------|---|
| 25-Jan-2007 | 1 | First release |
| 20-Mar-2007 | 2 | Typo mistake in first page (order codes) |
| 27-Apr-2007 | 3 | Updates on Table 6: Dynamic |
| 10-Dec-2009 | 4 | Modified device summary on first page |

Please Read Carefully:

Information in this document is provided solely in connection with ST products. STMicroelectronics NV and its subsidiaries ("ST") reserve the right to make changes, corrections, modifications or improvements, to this document, and the products and services described herein at any time, without notice.

All ST products are sold pursuant to ST's terms and conditions of sale.

Purchasers are solely responsible for the choice, selection and use of the ST products and services described herein, and ST assumes no liability whatsoever relating to the choice, selection or use of the ST products and services described herein.

No license, express or implied, by estoppel or otherwise, to any intellectual property rights is granted under this document. If any part of this document refers to any third party products or services it shall not be deemed a license grant by ST for the use of such third party products or services, or any intellectual property contained therein or considered as a warranty covering the use in any manner whatsoever of such third party products or services or any intellectual property contained therein.

UNLESS OTHERWISE SET FORTH IN ST'S TERMS AND CONDITIONS OF SALE ST DISCLAIMS ANY EXPRESS OR IMPLIED WARRANTY WITH RESPECT TO THE USE AND/OR SALE OF ST PRODUCTS INCLUDING WITHOUT LIMITATION IMPLIED WARRANTIES OF MERCHANTABILITY, FITNESS FOR A PARTICULAR PURPOSE (AND THEIR EQUIVALENTS UNDER THE LAWS OF ANY JURISDICTION), OR INFRINGEMENT OF ANY PATENT, COPYRIGHT OR OTHER INTELLECTUAL PROPERTY RIGHT.

UNLESS EXPRESSLY APPROVED IN WRITING BY AN AUTHORIZED ST REPRESENTATIVE, ST PRODUCTS ARE NOT RECOMMENDED, AUTHORIZED OR WARRANTED FOR USE IN MILITARY, AIR CRAFT, SPACE, LIFE SAVING, OR LIFE SUSTAINING APPLICATIONS, NOR IN PRODUCTS OR SYSTEMS WHERE FAILURE OR MALFUNCTION MAY RESULT IN PERSONAL INJURY, DEATH, OR SEVERE PROPERTY OR ENVIRONMENTAL DAMAGE. ST PRODUCTS WHICH ARE NOT SPECIFIED AS "AUTOMOTIVE GRADE" MAY ONLY BE USED IN AUTOMOTIVE APPLICATIONS AT USER'S OWN RISK.

Resale of ST products with provisions different from the statements and/or technical features set forth in this document shall immediately void any warranty granted by ST for the ST product or service described herein and shall not create or extend in any manner whatsoever, any liability of ST.

ST and the ST logo are trademarks or registered trademarks of ST in various countries.

Information in this document supersedes and replaces all information previously supplied.

The ST logo is a registered trademark of STMicroelectronics. All other names are the property of their respective owners.

© 2009 STMicroelectronics - All rights reserved

STMicroelectronics group of companies

Australia - Belgium - Brazil - Canada - China - Czech Republic - Finland - France - Germany - Hong Kong - India - Israel - Italy - Japan - Malaysia - Malta - Morocco - Philippines - Singapore - Spain - Sweden - Switzerland - United Kingdom - United States of America

www.st.com