



Chipsmall Limited consists of a professional team with an average of over 10 year of expertise in the distribution of electronic components. Based in Hongkong, we have already established firm and mutual-benefit business relationships with customers from,Europe,America and south Asia,supplying obsolete and hard-to-find components to meet their specific needs.

With the principle of “Quality Parts,Customers Priority,Honest Operation,and Considerate Service”,our business mainly focus on the distribution of electronic components. Line cards we deal with include Microchip,ALPS,ROHM,Xilinx,Pulse,ON,Everlight and Freescale. Main products comprise IC,Modules,Potentiometer,IC Socket,Relay,Connector.Our parts cover such applications as commercial,industrial, and automotives areas.

We are looking forward to setting up business relationship with you and hope to provide you with the best service and solution. Let us make a better world for our industry!



Contact us

Tel: +86-755-8981 8866 Fax: +86-755-8427 6832

Email & Skype: info@chipsmall.com Web: www.chipsmall.com

Address: A1208, Overseas Decoration Building, #122 Zhenhua RD., Futian, Shenzhen, China



N-channel 600 V, 1.06 Ω typ., 4.5 A MDmesh™ M2 Power MOSFETs in TO-220FP, TO-220 and IPAK packages

Datasheet - production data

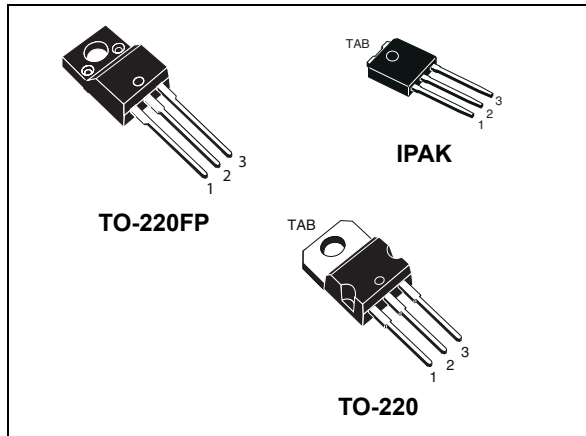
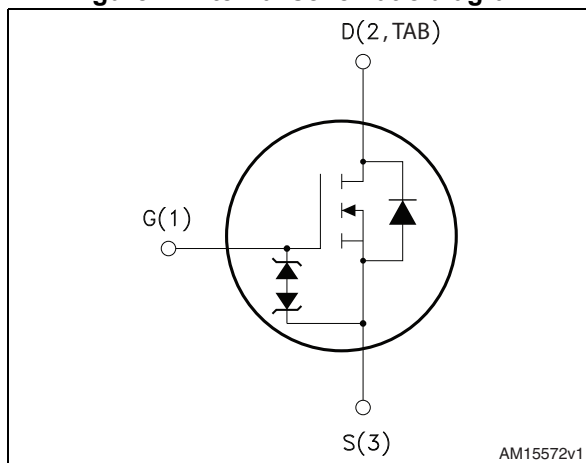

Figure 1. Internal schematic diagram



Features

| Order code | $V_{DS} @ T_{Jmax}$ | $R_{DS(on) max}$ | I_D |
|------------|---------------------|------------------|-------|
| STF6N60M2 | 650 V | 1.2 Ω | 4.5 A |
| STP6N60M2 | | | |
| STU6N60M2 | | | |

- Extremely low gate charge
- Excellent output capacitance (C_{OSS}) profile
- 100% avalanche tested
- Zener-protected

Applications

- Switching applications

Description

These devices are N-channel Power MOSFETs developed using MDmesh™ M2 technology. Thanks to their strip layout and improved vertical structure, the devices exhibit low on-resistance and optimized switching characteristics, rendering them suitable for the most demanding high efficiency converters.

Table 1. Device summary

| Order code | Marking | Package | Packing |
|------------|---------|----------|---------|
| STF6N60M2 | 6N60M2 | TO-220FP | Tube |
| STP6N60M2 | | TO-220 | |
| STU6N60M2 | | IPAK | |

Contents

- 1 Electrical ratings 3**
- 2 Electrical characteristics 4**
 - 2.1 Electrical characteristics (curves) 6
- 3 Test circuits 9**
- 4 Package information 10**
 - 4.1 TO-220FP package information11
 - 4.2 TO-220 package information 13
 - 4.3 IPAK(TO-251) package information 15
- 5 Revision history 17**

1 Electrical ratings

Table 2. Absolute maximum ratings

| Symbol | Parameter | Value | | Unit |
|----------------|---|--------------------|--------------|------|
| | | TO-220FP | TO-220, IPAK | |
| V_{GS} | Gate-source voltage | ± 25 | | V |
| I_D | Drain current (continuous) at $T_C = 25\text{ °C}$ | 4.5 ⁽¹⁾ | 4.5 | A |
| I_D | Drain current (continuous) at $T_C = 100\text{ °C}$ | 2.9 ⁽¹⁾ | 2.9 | A |
| $I_{DM}^{(2)}$ | Drain current (pulsed) | 18 ⁽¹⁾ | 18 | A |
| P_{TOT} | Total dissipation at $T_C = 25\text{ °C}$ | 20 | 60 | W |
| V_{ISO} | Insulation withstand voltage (RMS) from all three leads to external heat sink ($t=1\text{ s}$; $T_C=25\text{ °C}$) | 2500 | | V |
| $dv/dt^{(3)}$ | Peak diode recovery voltage slope | 15 | | V/ns |
| $dv/dt^{(4)}$ | MOSFET dv/dt ruggedness | 50 | | |
| T_{stg} | Storage temperature | - 55 to 150 | | °C |
| T_j | Operating junction temperature | | | |

- Limited by maximum junction temperature.
- Pulse width limited by safe operating area.
- $I_{SD} \leq 4.5\text{ A}$, $di/dt \leq 400\text{ A}/\mu\text{s}$; $V_{DS\text{ peak}} < V_{(BR)DSS}$, $V_{DD}=400\text{ V}$
- $V_{DS} \leq 480\text{ V}$

Table 3. Thermal data

| Symbol | Parameter | Value | | | Unit |
|----------------|---|----------|--------|------|------|
| | | TO-220FP | TO-220 | IPAK | |
| $R_{thj-case}$ | Thermal resistance junction-case max | 6.25 | 2.08 | | °C/W |
| $R_{thj-amb}$ | Thermal resistance junction-ambient max | 62.5 | | 100 | °C/W |

Table 4. Avalanche characteristics

| Symbol | Parameter | Value | Unit |
|----------|---|-------|------|
| I_{AR} | Avalanche current, repetitive or not repetitive (pulse width limited by T_{jmax}) | 1 | A |
| E_{AS} | Single pulse avalanche energy (starting $T_j=25\text{ °C}$, $I_D=I_{AR}$; $V_{DD}=50$) | 86 | mJ |

2 Electrical characteristics

($T_C = 25\text{ °C}$ unless otherwise specified)

Table 5. On /off states

| Symbol | Parameter | Test conditions | Min. | Typ. | Max. | Unit |
|---------------|--|--|------|------|----------|---------------|
| $V_{(BR)DSS}$ | Drain-source breakdown voltage | $I_D = 1\text{ mA}$, $V_{GS} = 0$ | 600 | | | V |
| I_{DSS} | Zero gate voltage drain current ($V_{GS} = 0$) | $V_{DS} = 600\text{ V}$ | | | 1 | μA |
| | | $V_{DS} = 600\text{ V}$, $T_C = 125\text{ °C}$ | | | 100 | μA |
| I_{GSS} | Gate-body leakage current ($V_{DS} = 0$) | $V_{GS} = \pm 25\text{ V}$ | | | ± 10 | μA |
| $V_{GS(th)}$ | Gate threshold voltage | $V_{DS} = V_{GS}$, $I_D = 250\text{ }\mu\text{A}$ | 2 | 3 | 4 | V |
| $R_{DS(on)}$ | Static drain-source on-resistance | $V_{GS} = 10\text{ V}$, $I_D = 2.25\text{ A}$ | | 1.06 | 1.2 | Ω |

Table 6. Dynamic

| Symbol | Parameter | Test conditions | Min. | Typ. | Max. | Unit |
|----------------------------|-------------------------------|--|------|------|------|----------|
| C_{iss} | Input capacitance | $V_{DS} = 100\text{ V}$, $f = 1\text{ MHz}$, $V_{GS} = 0$ | - | 232 | - | pF |
| C_{oss} | Output capacitance | | - | 14 | - | pF |
| C_{rss} | Reverse transfer capacitance | | - | 0.7 | - | pF |
| $C_{oss\text{ eq.}}^{(1)}$ | Equivalent output capacitance | $V_{DS} = 0\text{ to }480\text{ V}$, $V_{GS} = 0$ | - | 71 | - | pF |
| R_G | Intrinsic gate resistance | $f = 1\text{ MHz}$ open drain | - | 6.5 | - | Ω |
| Q_g | Total gate charge | $V_{DD} = 480\text{ V}$, $I_D = 4.5\text{ A}$, $V_{GS} = 10\text{ V}$ (see Figure 18) | - | 8 | - | nC |
| Q_{gs} | Gate-source charge | | - | 1.7 | - | nC |
| Q_{gd} | Gate-drain charge | | - | 4 | - | nC |

1. $C_{oss\text{ eq.}}$ is defined as a constant equivalent capacitance giving the same charging time as C_{oss} when V_{DS} increases from 0 to 80% V_{DSS}

Table 7. Switching times

| Symbol | Parameter | Test conditions | Min. | Typ. | Max. | Unit |
|--------------|---------------------|---|------|------|------|------|
| $t_{d(on)}$ | Turn-on delay time | $V_{DD} = 300\text{ V}$, $I_D = 1.65\text{ A}$, $R_G = 4.7\text{ }\Omega$, $V_{GS} = 10\text{ V}$ (see Figure 17 and Figure 22) | - | 9.5 | - | ns |
| t_r | Rise time | | - | 7.4 | - | ns |
| $t_{d(off)}$ | Turn-off delay time | | - | 24 | - | ns |
| t_f | Fall time | | - | 22.5 | - | ns |

Table 8. Source drain diode

| Symbol | Parameter | Test conditions | Min. | Typ. | Max. | Unit |
|-----------------|-------------------------------|--|------|------|------|---------------|
| I_{SD} | Source-drain current | | - | | 4.5 | A |
| $I_{SDM}^{(1)}$ | Source-drain current (pulsed) | | - | | 18 | A |
| $V_{SD}^{(2)}$ | Forward on voltage | $I_{SD} = 4.5 \text{ A}$, $V_{GS} = 0$ | - | | 1.6 | V |
| t_{rr} | Reverse recovery time | $I_{SD} = 4.5 \text{ A}$, $di/dt = 100 \text{ A}/\mu\text{s}$ $V_{DD} = 60 \text{ V}$ (see Figure 19) | - | 274 | | ns |
| Q_{rr} | Reverse recovery charge | | - | 1.47 | | μC |
| I_{RRM} | Reverse recovery current | | - | 10.7 | | A |
| t_{rr} | Reverse recovery time | $I_{SD} = 4.5 \text{ A}$, $di/dt = 100 \text{ A}/\mu\text{s}$ $V_{DD} = 60 \text{ V}$, $T_j = 150 \text{ }^\circ\text{C}$ (see Figure 19) | - | 376 | | ns |
| Q_{rr} | Reverse recovery charge | | - | 1.96 | | μC |
| I_{RRM} | Reverse recovery current | | - | 10.5 | | A |

1. Pulse width limited by safe operating area.
2. Pulsed: pulse duration = 300 μs , duty cycle 1.5%

2.1 Electrical characteristics (curves)

Figure 2. Safe operating area for TO-220FP

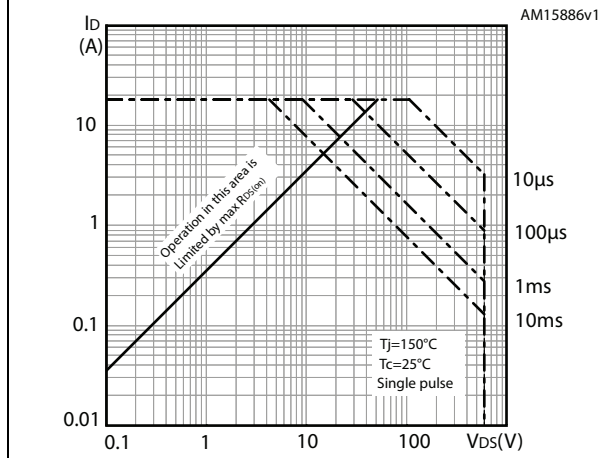

Figure 3. Thermal impedance for TO-220FP

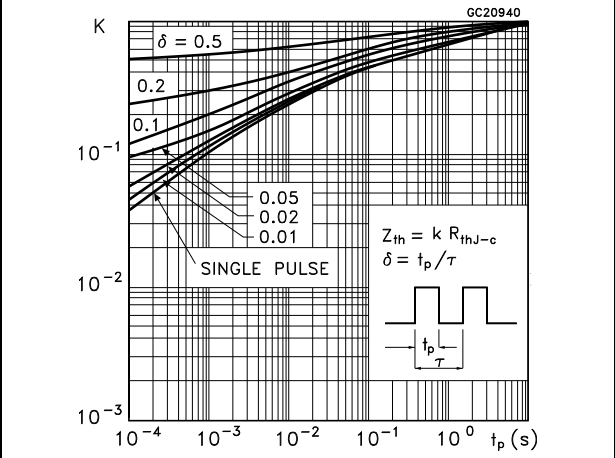

Figure 4. Safe operating area for TO-220

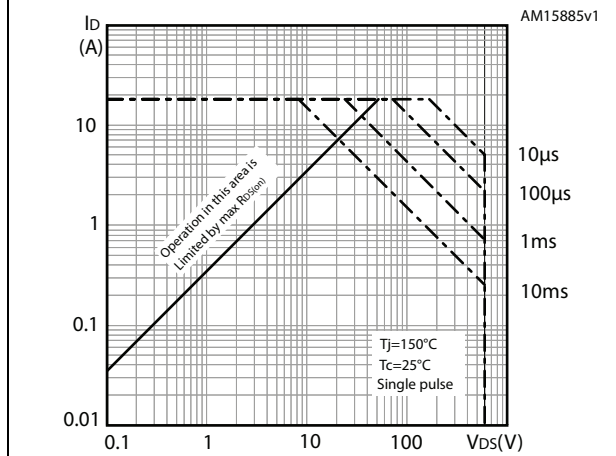

Figure 5. Thermal impedance for TO-220

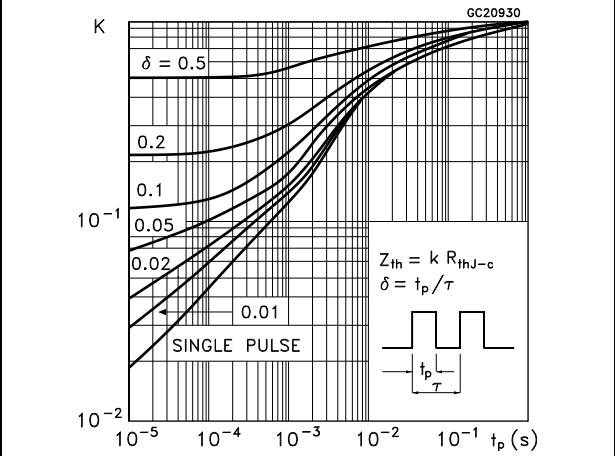

Figure 6. Safe operating area for IPAK

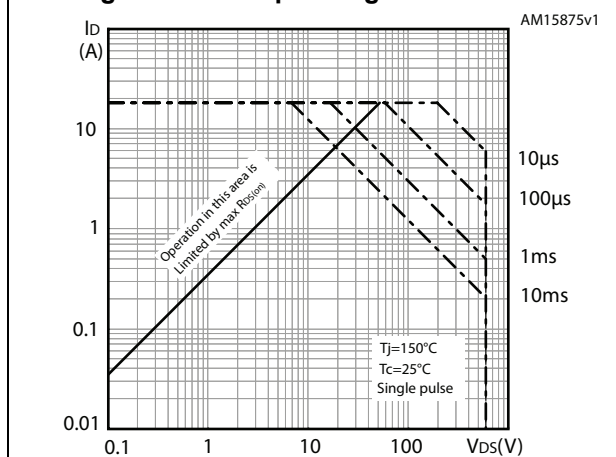
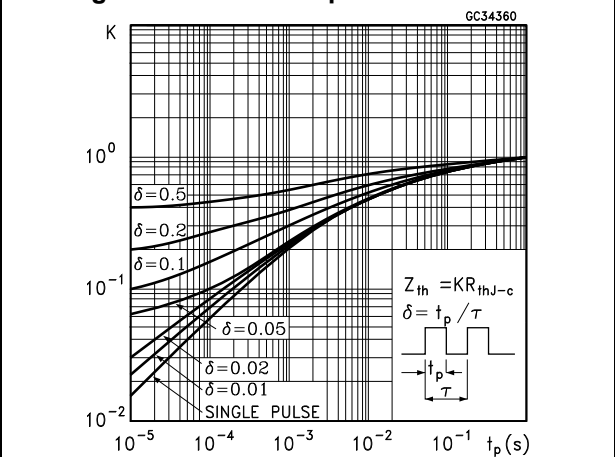

Figure 7. Thermal impedance for IPAK



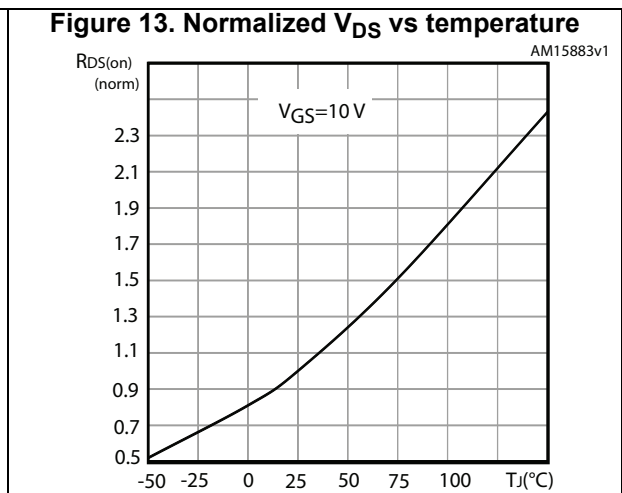
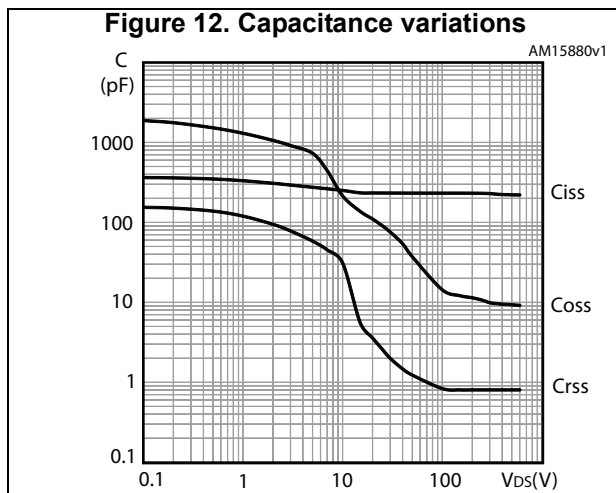
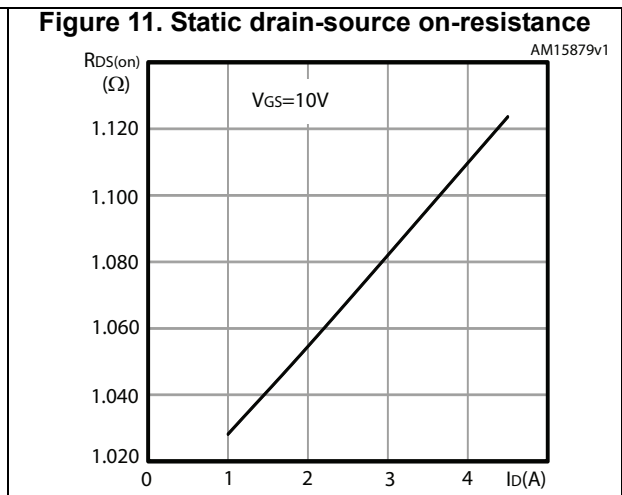
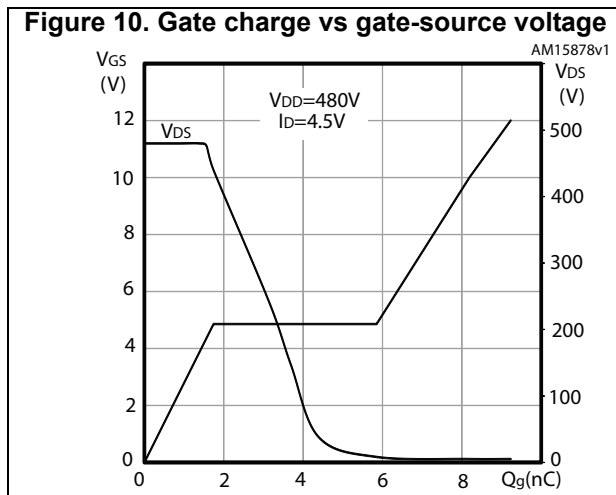
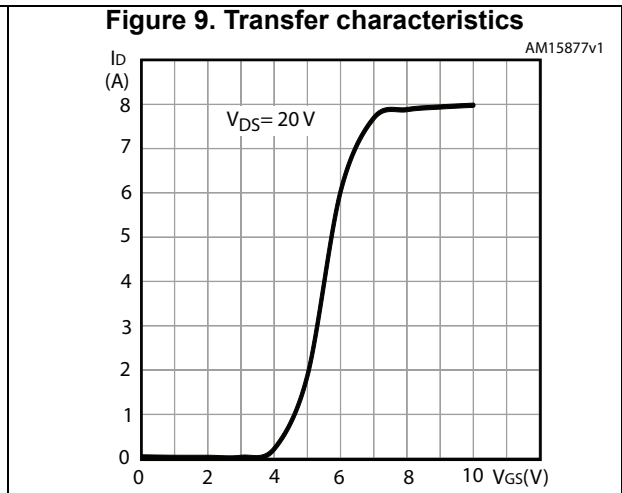
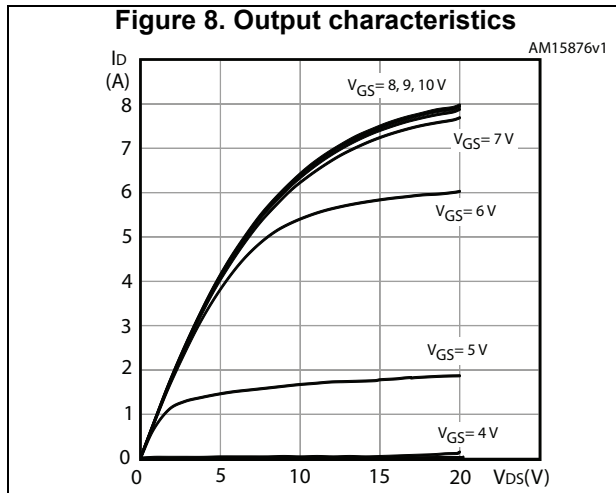

Figure 14. Normalized gate threshold voltage vs temperature

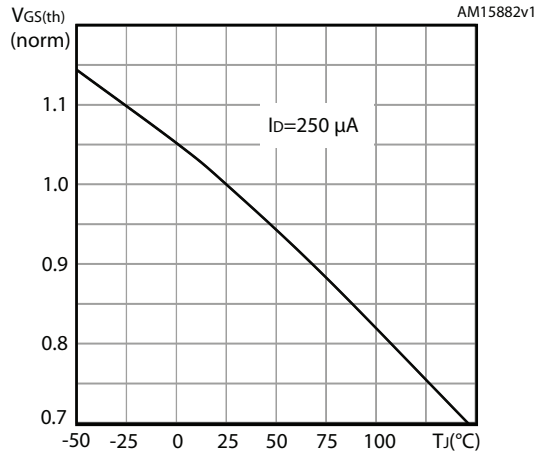

Figure 15. Normalized on-resistance vs temperature

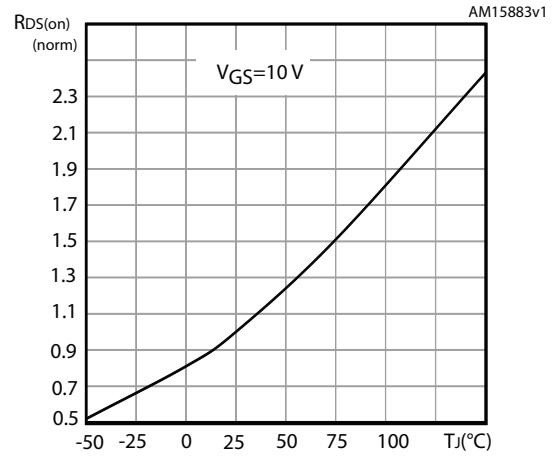
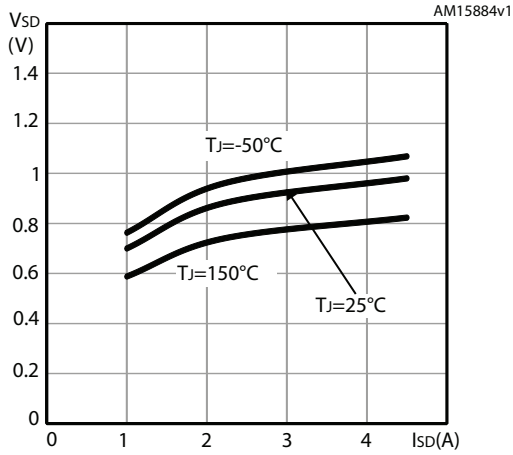
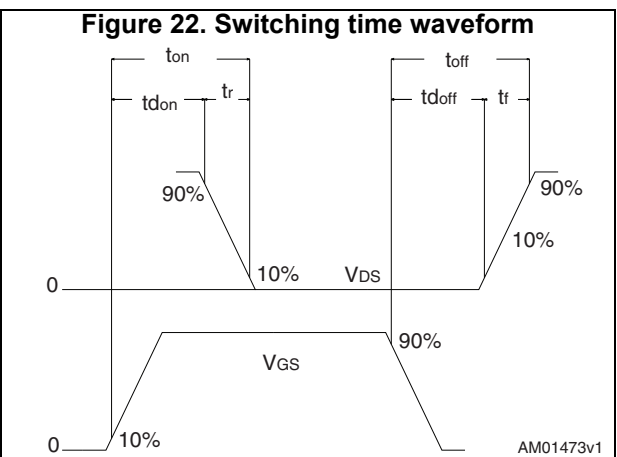
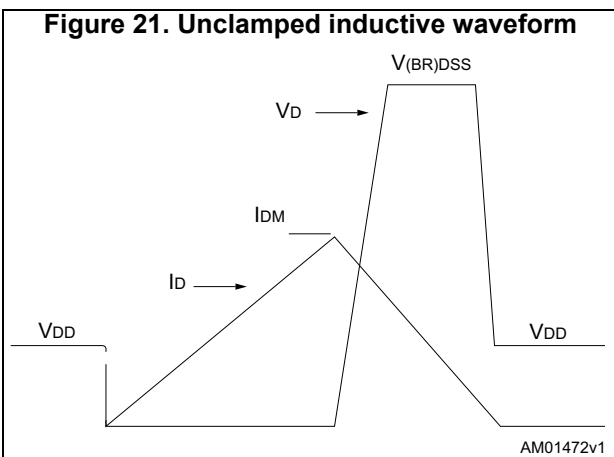
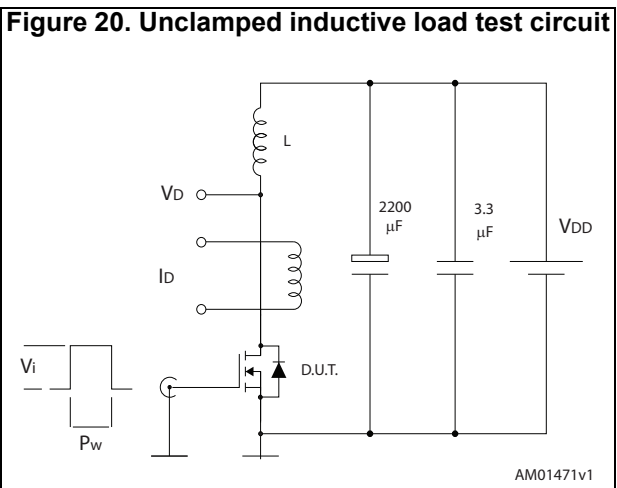
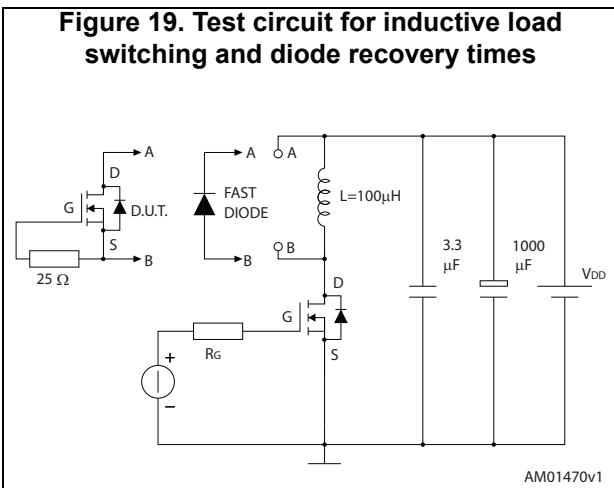
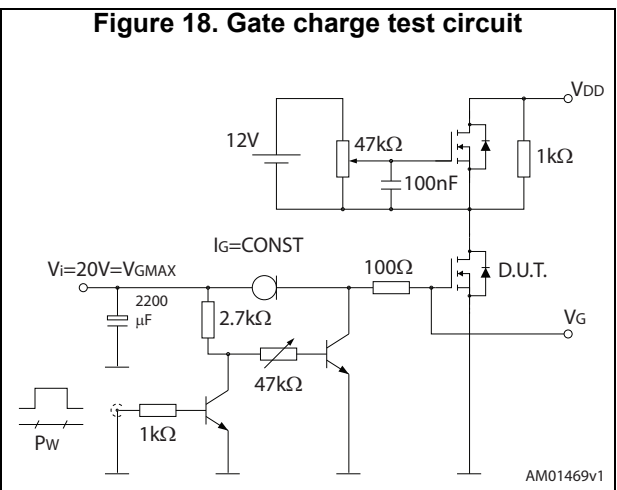
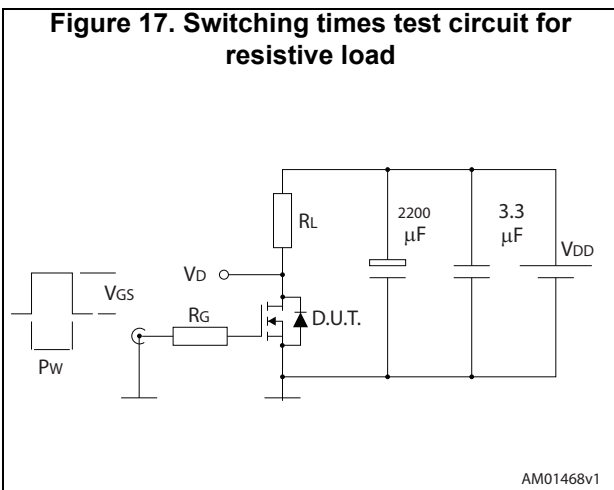

Figure 16. Source-drain diode forward characteristics



3 Test circuits



4 Package information

In order to meet environmental requirements, ST offers these devices in different grades of ECOPACK[®] packages, depending on their level of environmental compliance. ECOPACK[®] specifications, grade definitions and product status are available at: www.st.com. ECOPACK[®] is an ST trademark.

4.1 TO-220FP package information

Figure 23. TO-220FP package outline

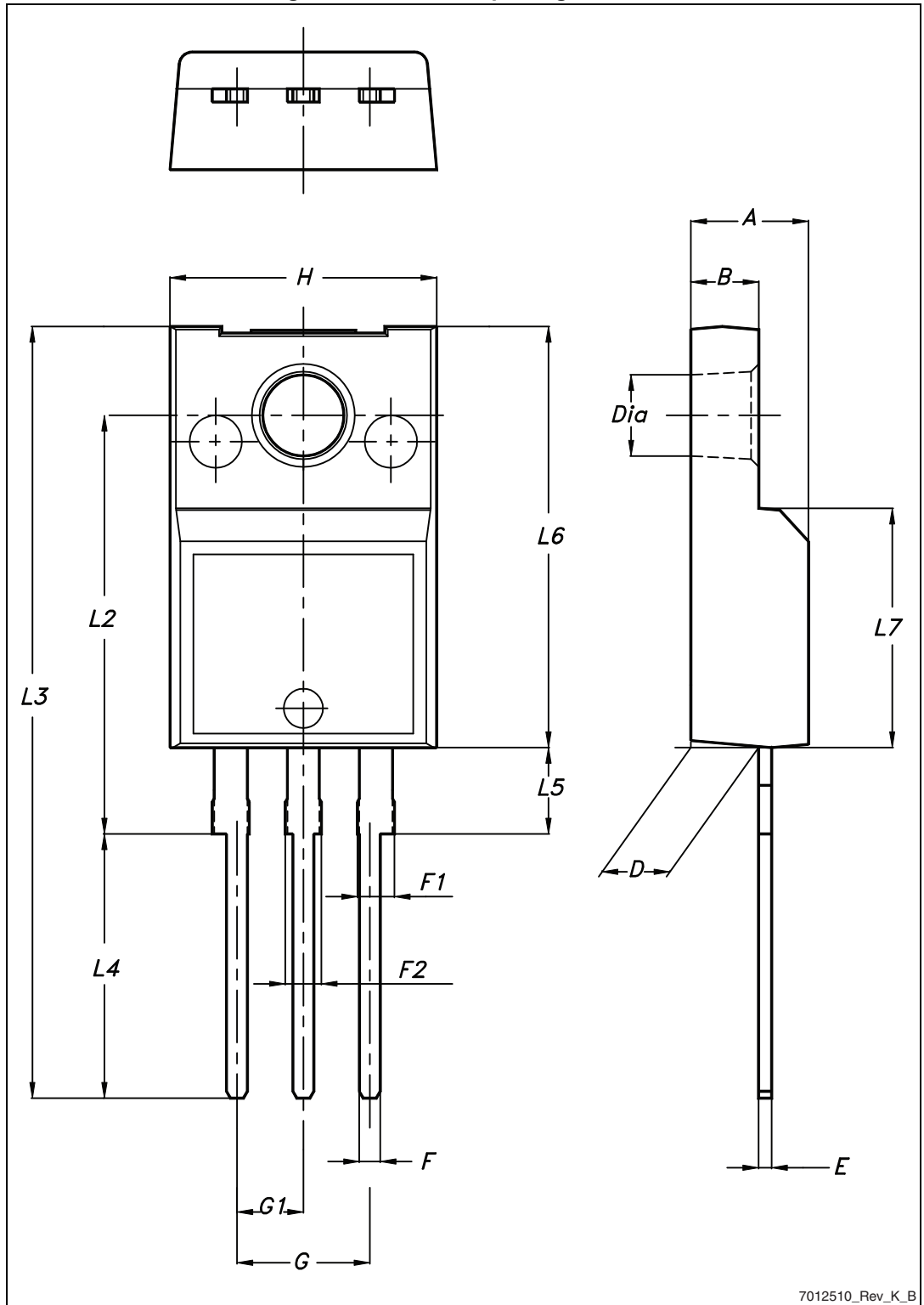

7012510_Rev_K_B

Table 9. TO-220FP mechanical data

| Dim. | mm | | |
|------|------|------|------|
| | Min. | Typ. | Max. |
| A | 4.4 | | 4.6 |
| B | 2.5 | | 2.7 |
| D | 2.5 | | 2.75 |
| E | 0.45 | | 0.7 |
| F | 0.75 | | 1 |
| F1 | 1.15 | | 1.70 |
| F2 | 1.15 | | 1.70 |
| G | 4.95 | | 5.2 |
| G1 | 2.4 | | 2.7 |
| H | 10 | | 10.4 |
| L2 | | 16 | |
| L3 | 28.6 | | 30.6 |
| L4 | 9.8 | | 10.6 |
| L5 | 2.9 | | 3.6 |
| L6 | 15.9 | | 16.4 |
| L7 | 9 | | 9.3 |
| Dia | 3 | | 3.2 |

4.2 TO-220 package information

Figure 24. TO-220 type A package outline

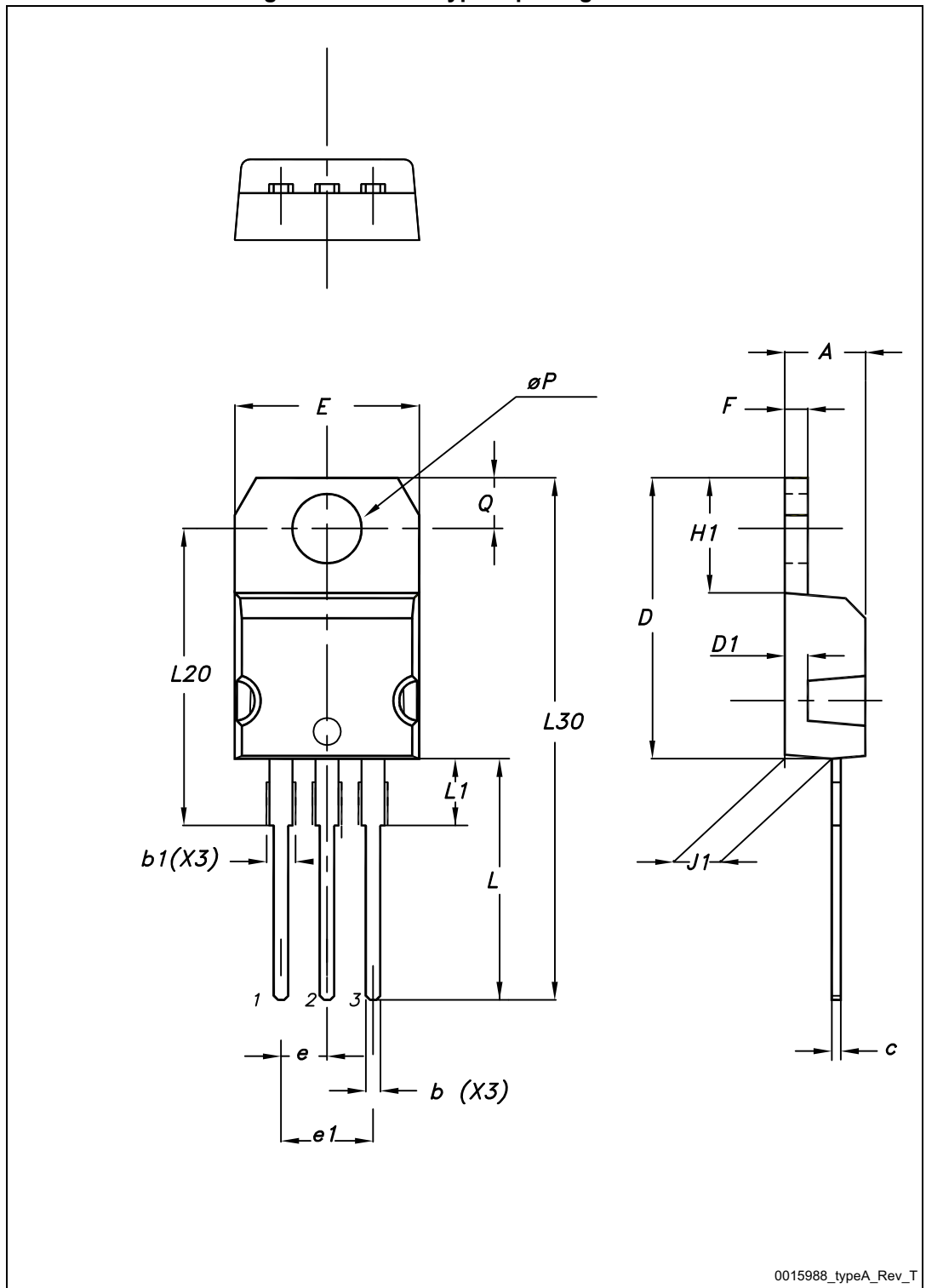

0015988_typeA_Rev_T

Table 10. TO-220 type A mechanical data

| Dim. | mm | | |
|------|-------|-------|-------|
| | Min. | Typ. | Max. |
| A | 4.40 | | 4.60 |
| b | 0.61 | | 0.88 |
| b1 | 1.14 | | 1.70 |
| c | 0.48 | | 0.70 |
| D | 15.25 | | 15.75 |
| D1 | | 1.27 | |
| E | 10 | | 10.40 |
| e | 2.40 | | 2.70 |
| e1 | 4.95 | | 5.15 |
| F | 1.23 | | 1.32 |
| H1 | 6.20 | | 6.60 |
| J1 | 2.40 | | 2.72 |
| L | 13 | | 14 |
| L1 | 3.50 | | 3.93 |
| L20 | | 16.40 | |
| L30 | | 28.90 | |
| ØP | 3.75 | | 3.85 |
| Q | 2.65 | | 2.95 |

4.3 IPAK(TO-251) package information

Figure 25. IPAK (TO-251) type A package outline

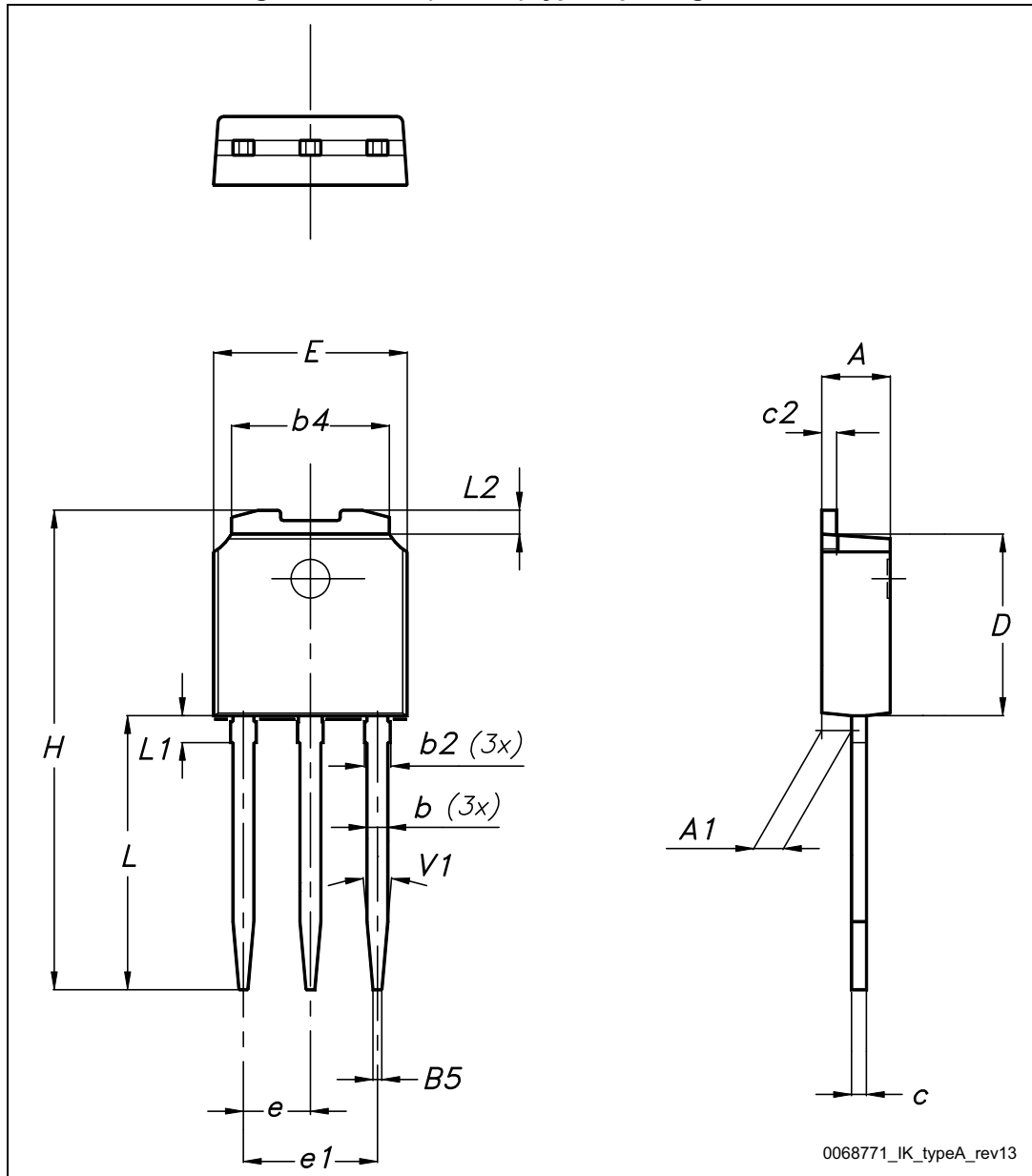

Table 11. IPAK (TO-251) type A mechanical data

| DIM | mm. | | |
|-----|------|-------|------|
| | min. | typ. | max. |
| A | 2.20 | | 2.40 |
| A1 | 0.90 | | 1.10 |
| b | 0.64 | | 0.90 |
| b2 | | | 0.95 |
| b4 | 5.20 | | 5.40 |
| B5 | | 0.30 | |
| c | 0.45 | | 0.60 |
| c2 | 0.48 | | 0.60 |
| D | 6.00 | | 6.20 |
| E | 6.40 | | 6.60 |
| e | | 2.28 | |
| e1 | 4.40 | | 4.60 |
| H | | 16.10 | |
| L | 9.00 | | 9.40 |
| L1 | 0.80 | | 1.20 |
| L2 | | 0.80 | 1.00 |
| V1 | | 10° | |

5 Revision history

Table 12. Document revision history

| Date | Revision | Changes |
|-------------|----------|---|
| 11-Jun-2013 | 1 | First release. |
| 01-Oct-2015 | 2 | Updated title, features and description. Updated Table 2.: Absolute maximum ratings and Table 8.: Source drain diode . Updated 4.3: IPAK(TO-251) package information . Minor text changes. |

IMPORTANT NOTICE – PLEASE READ CAREFULLY

STMicroelectronics NV and its subsidiaries ("ST") reserve the right to make changes, corrections, enhancements, modifications, and improvements to ST products and/or to this document at any time without notice. Purchasers should obtain the latest relevant information on ST products before placing orders. ST products are sold pursuant to ST's terms and conditions of sale in place at the time of order acknowledgement.

Purchasers are solely responsible for the choice, selection, and use of ST products and ST assumes no liability for application assistance or the design of Purchasers' products.

No license, express or implied, to any intellectual property right is granted by ST herein.

Resale of ST products with provisions different from the information set forth herein shall void any warranty granted by ST for such product.

ST and the ST logo are trademarks of ST. All other product or service names are the property of their respective owners.

Information in this document supersedes and replaces information previously supplied in any prior versions of this document.

© 2015 STMicroelectronics – All rights reserved