



Chipsmall Limited consists of a professional team with an average of over 10 year of expertise in the distribution of electronic components. Based in Hongkong, we have already established firm and mutual-benefit business relationships with customers from,Europe,America and south Asia,supplying obsolete and hard-to-find components to meet their specific needs.

With the principle of “Quality Parts,Customers Priority,Honest Operation,and Considerate Service”,our business mainly focus on the distribution of electronic components. Line cards we deal with include Microchip,ALPS,ROHM,Xilinx,Pulse,ON,Everlight and Freescale. Main products comprise IC,Modules,Potentiometer,IC Socket,Relay,Connector.Our parts cover such applications as commercial,industrial, and automotives areas.

We are looking forward to setting up business relationship with you and hope to provide you with the best service and solution. Let us make a better world for our industry!



Contact us

Tel: +86-755-8981 8866 Fax: +86-755-8427 6832

Email & Skype: info@chipsmall.com Web: www.chipsmall.com

Address: A1208, Overseas Decoration Building, #122 Zhenhua RD., Futian, Shenzhen, China





STG3689

Low Voltage 0.9Ω max dual SPDT Switch with break-before-make feature

Features

- Low quiescent supply current:
 - Max $\pm 50\mu\text{A}$ for $V_{1\text{IN}}, V_{2\text{IN}} = 1.80\text{V}$ at $V_{\text{CC}} = 4.3\text{V}$
- Ultra low power dissipation:
 - $I_{\text{CC}} = 0.2\mu\text{A}$ (Max.) at $T_A = 85^\circ\text{C}$, $V_{\text{IN}} = 0\text{V}$
- Switch S1: Low “ON” resistance $V_{\text{IN}} = 0\text{V}$:
 - $R_{\text{ON}} = 0.7\Omega$ (Max. $T_A = 25^\circ\text{C}$) at $V_{\text{CC}} = 4.3\text{V}$
 - $R_{\text{ON}} = 0.9\Omega$ (Max. $T_A = 25^\circ\text{C}$) at $V_{\text{CC}} = 3\text{V}$
- Wide operating voltage range:
 - V_{CC} (OPR) = 1.65V to 4.3V single supply
- 4.3V Tolerant and 1.8V compatible threshold on digital control input at $V_{\text{CC}} = 1.65$ to 4.3V
- Latch-up performance exceed 300mA (JESD 17)
- ESD performance (Analog chan. Vs. GND):
 - HBM >2kV (MIL STD 883 method 3015)

Description

The STG3689 is a high-speed CMOS low voltage dual analog S.P.D.T. (Single Pole Dual Throw) switch or 2:1 Multiplexer/Demultiplexer switch fabricated in silicon gate C²MOS technology. It is designed to operate from 1.65V to 4.3V, making this device ideal for portable applications.

The nIN inputs are provided to control the switches.

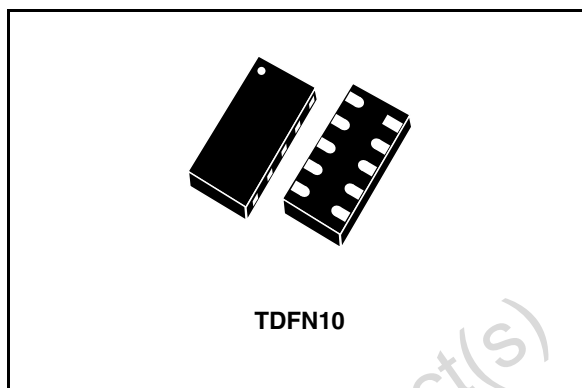

The switches nS1 are ON (they are connected to common Ports Dn) when the nIN input is held high and OFF (high impedance state exists between the two ports) when nIN is held low. The switches nS2 are ON (they are connected to common Ports Dn) when the nIN input is held low and OFF (high impedance state exists between the two ports) when IN is held high.

Additional key features are fast switching speed, and ultra low power consumption. All inputs and outputs are equipped with protection circuits against static discharge, giving them ESD immunity and transient excess voltage.

Order codes

Part number	Package	Packaging
STG3689DTR	TDFN10 (2.5mm x 1.3mm)	Tape & Reel

Contents

1	Summary description	3
1.1	Pin connections and description	3
1.2	Input equivalent circuit	3
2	Electrical ratings	4
3	Electrical characteristics	5
3.1	Recommended operating conditions	5
3.2	DC Specifications	5
3.3	AC electrical characteristics	7
3.4	Analog switch characteristics	8
3.5	Truth table	8
4	Application circuits	9
5	Package mechanical data	13
6	Revision history	15

Obsolete Product(s) - Obsolete Product(s)

1 Summary description

1.1 Pin connections and description

Figure 1. Pin connections (Top through view)

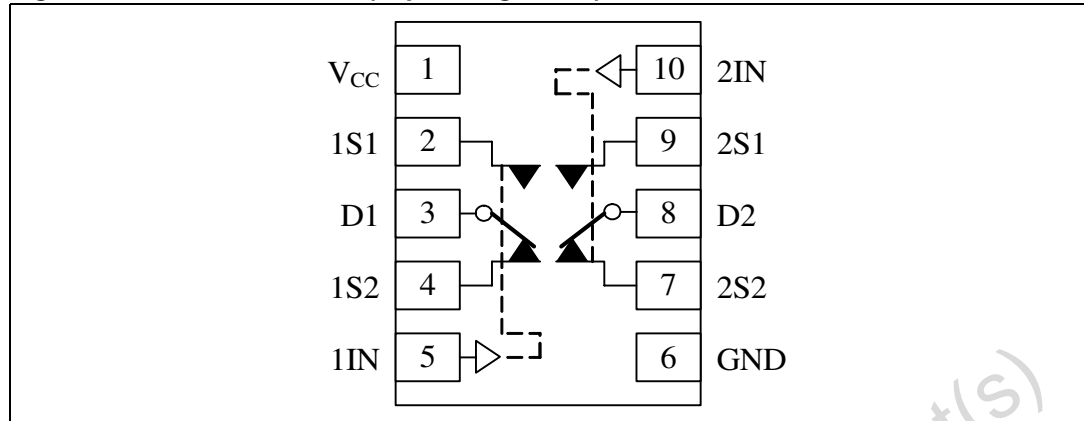
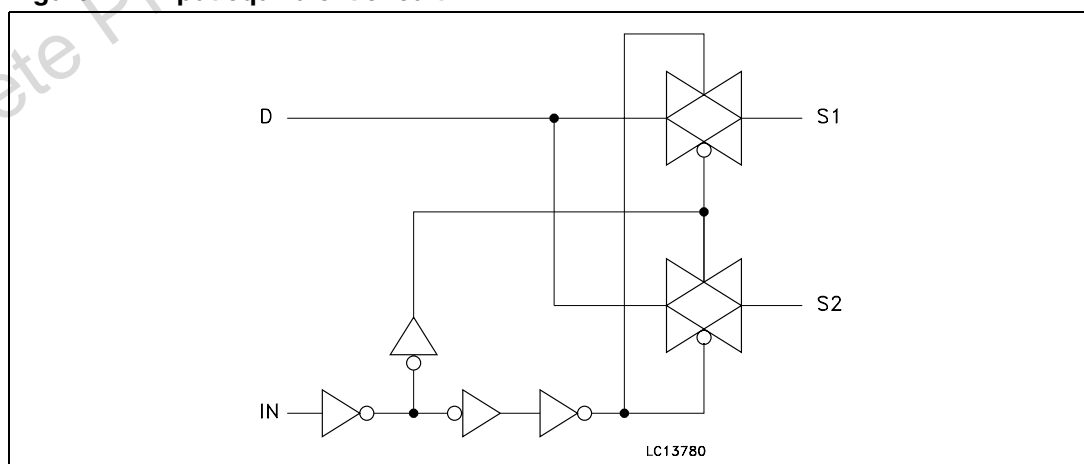

Table 1. Pin function

Pin N°	Symbol	Name and function
5, 10	1IN, 2IN	Controls
2, 4, 9, 7	1S1, 1S2 2S1, 2S2	Independent channels
3, 8	D1, D2	Common channels
1	V _{CC}	Positive supply voltage
6	GND	Ground (0V)

1.2 Input equivalent circuit

Figure 2. Input equivalent circuit



2 Electrical ratings

Stressing the device above the rating listed in the “Absolute Maximum Ratings” table may cause permanent damage to the device. These are stress ratings only and operation of the device at these or any other conditions above those indicated in the Operating sections of this specification is not implied. Exposure to Absolute Maximum Rating conditions for extended periods may affect device reliability. Refer also to the STMicroelectronics SURE Program and other relevant quality documents.

Table 2. Absolute maximum ratings

Symbol	Parameter	Value	Unit
V_{CC}	Supply voltage	-0.5 to 5.5	V
V_I	DC input voltage	-0.5 to $V_{CC} + 0.5$	V
V_{IC}	DC control input voltage	-0.5 to 5.5	V
V_O	DC output voltage	-0.5 to $V_{CC} + 0.5$	V
I_{IKC}	DC input diode current on control pin ($V_{IN} < 0V$)	-50	mA
I_{IK}	DC input diode current ($V_{IN} < 0V$)	± 50	mA
I_{OK}	DC output diode current	± 20	mA
I_O	DC output current	± 200	mA
I_{OP}	DC output current peak (pulse at 1ms, 10% duty cycle)	± 400	mA
I_{CC} or I_{GND}	DC V_{CC} or ground current	± 100	mA
P_D	Power dissipation at $T_A = 70^\circ C$ ⁽¹⁾	1120	mW
T_{stg}	Storage temperature	-65 to 150	$^\circ C$
T_L	Lead temperature (10 sec.)	300	$^\circ C$

1. Derate above 70 $^\circ C$ by 18.5mW/ $^\circ C$

3 Electrical characteristics

3.1 Recommended operating conditions

Table 3. Recommended operating conditions

Symbol	Parameter	Value	Unit	
V_{CC}	Supply voltage ⁽¹⁾	1.4 to 4.3	V	
V_I	Input voltage	0 to V_{CC}	V	
V_{IC}	Control input voltage	0 to 4.3	V	
V_O	Output voltage	0 to V_{CC}	V	
T_{op}	Operating temperature	-55 to 125	°C	
d_t/d_v	Input rise and fall time control Input	$V_{CC} = 1.65V$ to $2.7V$	0 to 20	ns/V
		$V_{CC} = 3.0$ to $4.3V$	0 to 10	

1. Truth Table guaranteed: 1.2V to 4.3V

3.2 DC Specifications

Table 4. DC specifications

Symbol	Parameter	Test conditions		Value						Unit	
		$V_{CC}(V)$		$T_A = 25^\circ C$			-40 to $85^\circ C$		-55 to $125^\circ C$		
				Min.	Typ	Max.	Typ	Max.	Typ		Max.
V_{IH}	High level input voltage	1.65-1.95		0.65			0.65		0.65		V
		2.3-2.5		1.4			1.4		1.4		
		2.7-3.0		1.4			1.4		1.4		
		3.3 – 4.3		1.5			1.5		1.5		
V_{IL}	Low level input voltage	1.65-1.95				0.40		0.40		0.40	V
		2.3-2.5				0.50		0.50		0.50	
		2.7-3.0				0.50		0.50		0.50	
		3.3 – 4.3				0.50		0.50		0.50	

Table 4. DC specifications

Symbol	Parameter	Test conditions		Value						Unit	
		V _{CC} (V)		T _A = 25°C			-40 to 85°C		-55 to 125°C		
				Min.	Typ	Max.	Typ	Max.	Typ		Max.
R _{ON}	Switch ON resistance	4.3	V _S =0V to V _{CC} I _S =100 mA		0.5	0.7		1.4			Ω
		3.0			0.7	0.9		1.4			
		2.7			0.7	0.9		1.7			
		2.3			0.9	1.2		1.7			
		1.8			1.3	1.6		1.9			
		1.65			1.60	2.5		2.2			
ΔR _{ON}	ON Resistance match between channels 1Sn and 2Sn	2.7	V _S @ R _{ON} Max I _S =100 mA		0.6						Ω
R _{FLAT}	ON resistance FLATNESS (1) (2)	4.3	V _S = 0V to V _{CC} I _S =100 mA		0.18	0.21					Ω
		3.0			0.16	0.19					
		2.7			0.16	0.19					
		2.3			0.18	0.21					
		1.65			0.38	0.44					
I _{OFF}	OFF state leakage current (nSN), (Dn)	4.3	V _S = 0.3 or 4V			±10		±100			nA
I _{IN}	Input leakage current	0 – 4.3	V _{IN} = 0 to 4.3V			±0.1		±1			μA
I _{CC}	Quiescent supply current	1.65–4.3	V _{IN} = V _{CC} or GND			±0.05		±0.2		±1	μA
I _{CCLV}	Quiescent supply current low voltage driving	4.3	V _{1IN} , V _{2IN} = 1.65V		42	55					μA
			V _{1IN} , V _{2IN} = 1.80V		38	50					

1. ΔRON = R_{ON}(MAX) - R_{ON}(MIN).
2. Flatness is defined as the difference between the maximum and minimum value of on-resistance as measured over the specified analog signal ranges.

3.3 AC electrical characteristics

Table 5. AC electrical characteristics ($C_L = 35\text{pF}$, $R_L = 50\Omega$, $t_r = t_f \leq 5\text{ns}$)

Symbol	Parameter	Test conditions		Value						Unit	
		$V_{CC}(V)$		$T_A = 25^\circ\text{C}$			$-40 \text{ to } 85^\circ\text{C}$		$-55 \text{ to } 125^\circ\text{C}$		
				Min.	Typ.	Max.	Typ.	Max.	Typ.		Max.
t_{PLH} , t_{PHL}	Propagation delay	1.65-1.95			0.45						ns
		2.3-2.7			0.40						
		3.0-3.3			0.30						
		3.6-4.3			0.30						
t_{ON}	TURN-ON time	1.65-1.95	$V_S = 0.8V$		70						ns
		2.3-2.7	$V_S = 1.5V$		30	60		75			
		3.0-3.3			25	50		60			
		3.6-4.3			25	50		60			
t_{OFF}	TURN-OFF time	1.65-1.95	$V_S = 0.8$		45						ns
		2.3-2.7	$V_S = 1.5V$		25	30		40			
		3.0-3.3			25	30		40			
		3.6-4.3			25	30		40			
t_D	Break before make time delay	1.65 – 1.95	$C_L = 35\text{pF}$ $R_L = 50\Omega$ $V_S = 1.5V$								ns
		2.3 – 2.7		2	15						
		3.0 – 3.6		2	15						
		3.6 – 4.3		2	15						
Q	Charge Injection	1.65-1.95	$C_L = 100\text{pF}$ $R_L = 1M\Omega$ $V_{GEN} = 0V$ $R_{GEN} = 0\Omega$		23						pC
		2.3 - 2.7			32						
		3.0 - 3.3			40						
		3.6 - 4.3			44						

3.4 Analog switch characteristics

Table 6. Analog switch characteristics ($C_L = 5\text{pF}$, $R_L = 50\Omega$, $T_A = 25^\circ\text{C}$)

Symbol	Parameter	Test Conditions		Value						Unit		
		$V_{CC}(V)$		$T_A = 25^\circ\text{C}$			-40 to 85°C		-55 to 125°C			
				Min.	Typ.	Max.	Typ.	Max.	Typ.		Max.	
OIRR	Off Isolation ⁽¹⁾	1.65 - 4.3	$V_S = 1V_{RMS}$ $f = 100\text{kHz}$		-90							dB
Xtalk	Crosstalk	1.6 - 4.3	$V_S = 1V_{RMS}$ $f = 100\text{kHz}$		-76							dB
THD	Total harmonic distortion	3.0	$R_L = 600\Omega$ $V_{IN} = 2V_{PP}$ $f = 20\text{Hz}$ to 20kHz		0.03							%
BW	-3dB Bandwidth	1.65 - 4.3	$R_L = 50\Omega$		85							MHz
C_{IN}	Control pin input capacitance				7							pF
C_{Sn}	Sn port capacitance	3.3	$f = 1\text{MHz}$		35							pF
C_D	D port capacitance when switch is enabled	3.3	$f = 1\text{MHz}$		99							pF

1. Off Isolation = $20\text{Log}_{10}(V_D/V_S)$, V_D = output, V_S = input at off switch.

3.5 Truth table

Table 7. Truth table

IN	Switch S1	Switch S2
H	ON	OFF ⁽¹⁾
L	OFF ⁽¹⁾	ON

1. High Impedance

4 Application circuits

Figure 3. ON Resistance

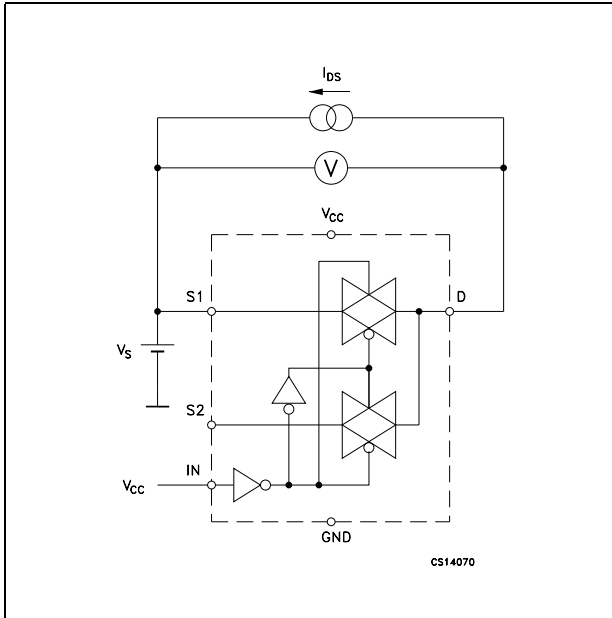

Figure 4. OFF Isolation

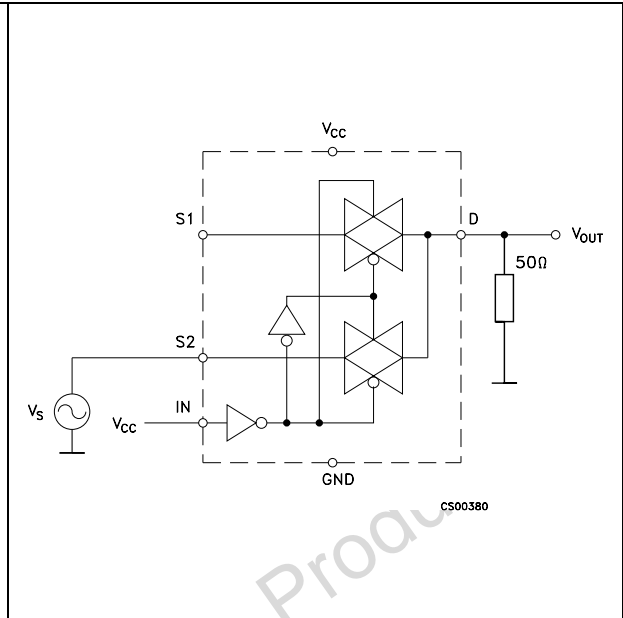

Figure 5. OFF Leakage

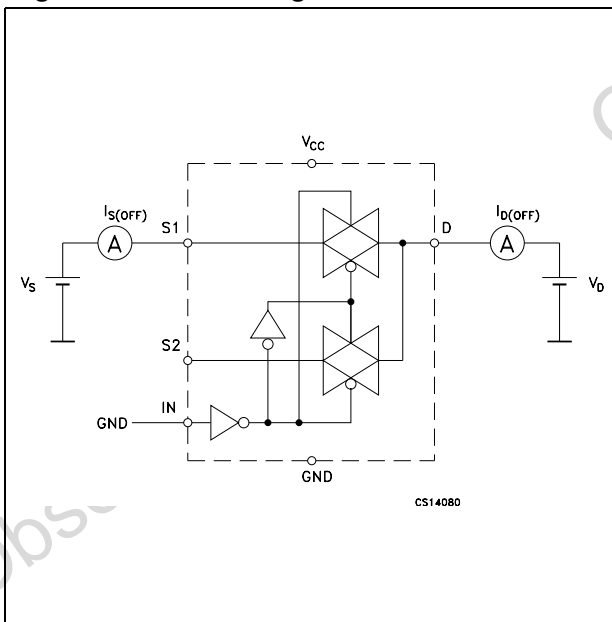

Figure 6. Bandwidth

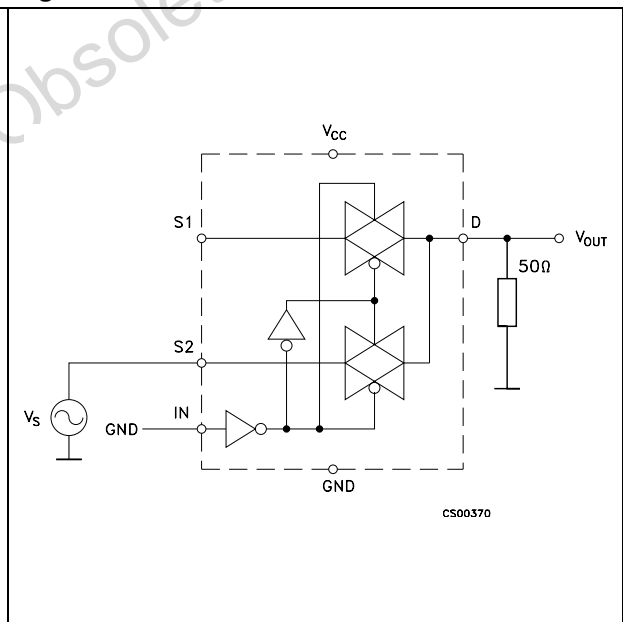

Figure 7. Channel to channel crosstalk

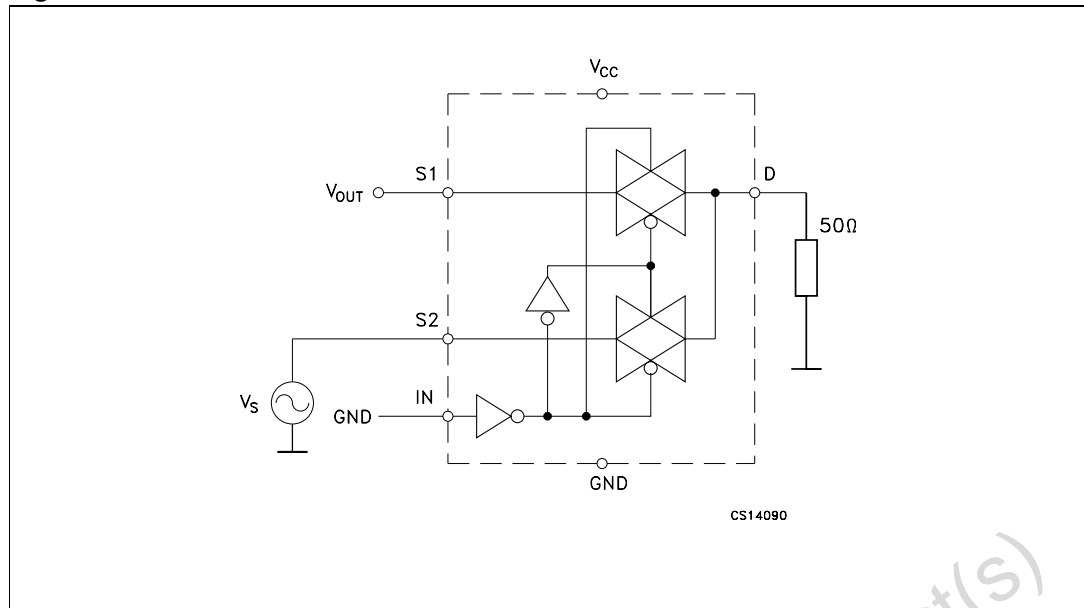
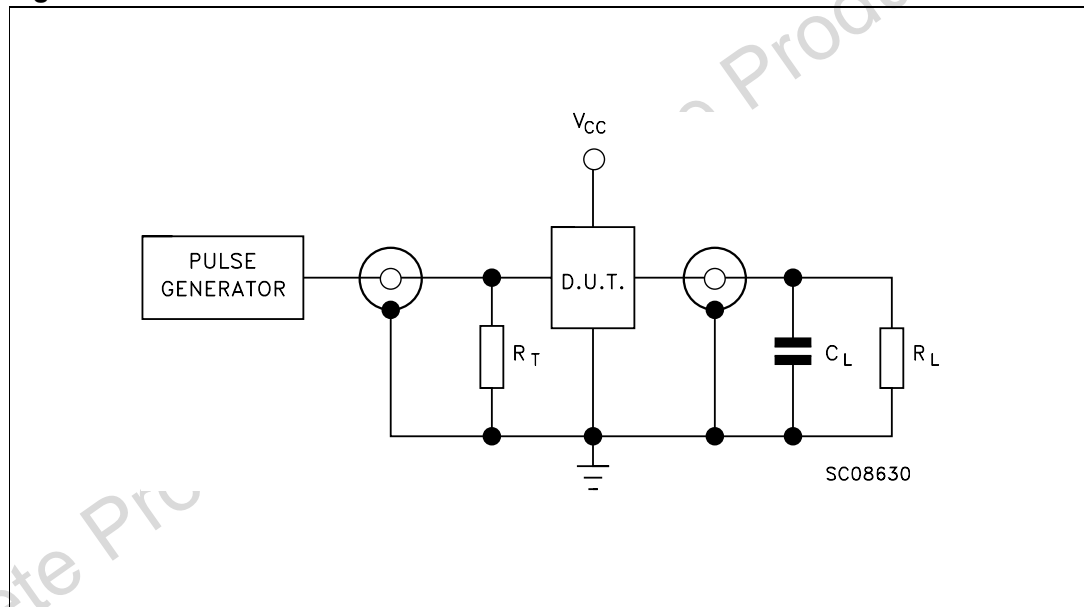

Figure 8. Test circuit



$C_L = 5/35\text{pF}$ or equivalent (includes jig and probe capacitance)

$R_L = 50\Omega$ or equivalent

$R_T = Z_{OUT}$ of pulse generator (typically 50Ω)

Figure 9. Break-before-make time delay

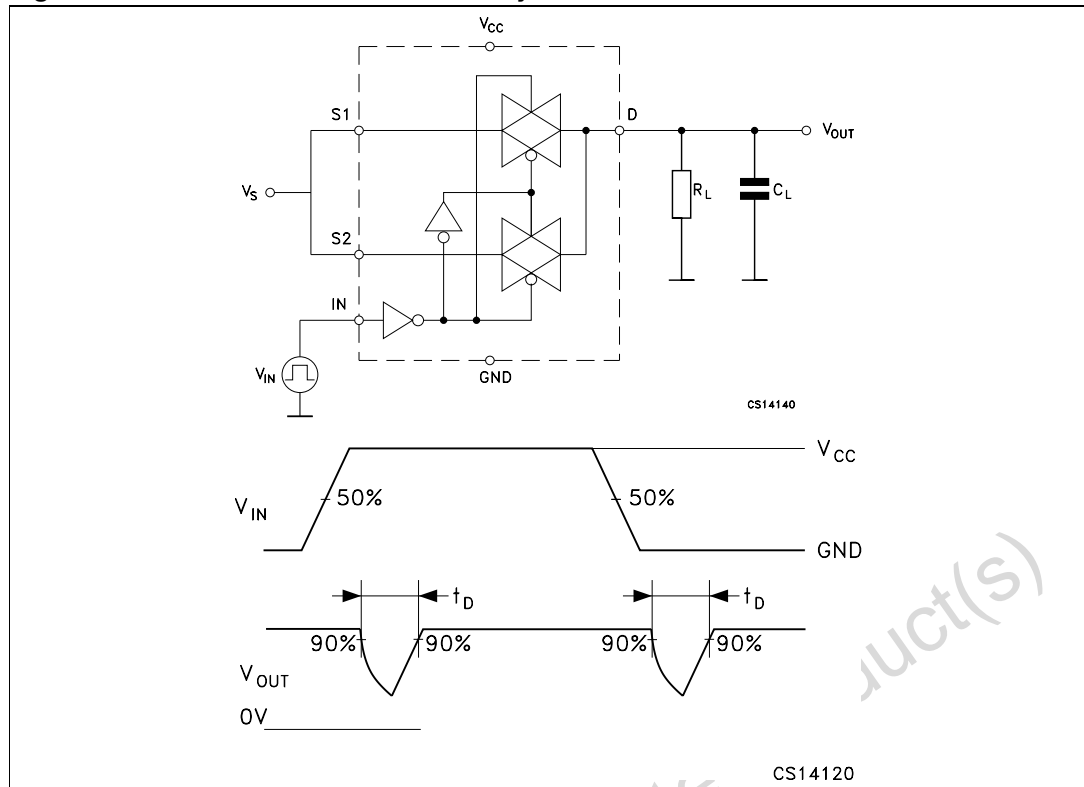

Figure 10. Switching time and charge injection
 ($V_{GEN} = 0V$, $R_{GEN} = 0\Omega$, $R_L = 1M\Omega$, $C_L = 100pF$)

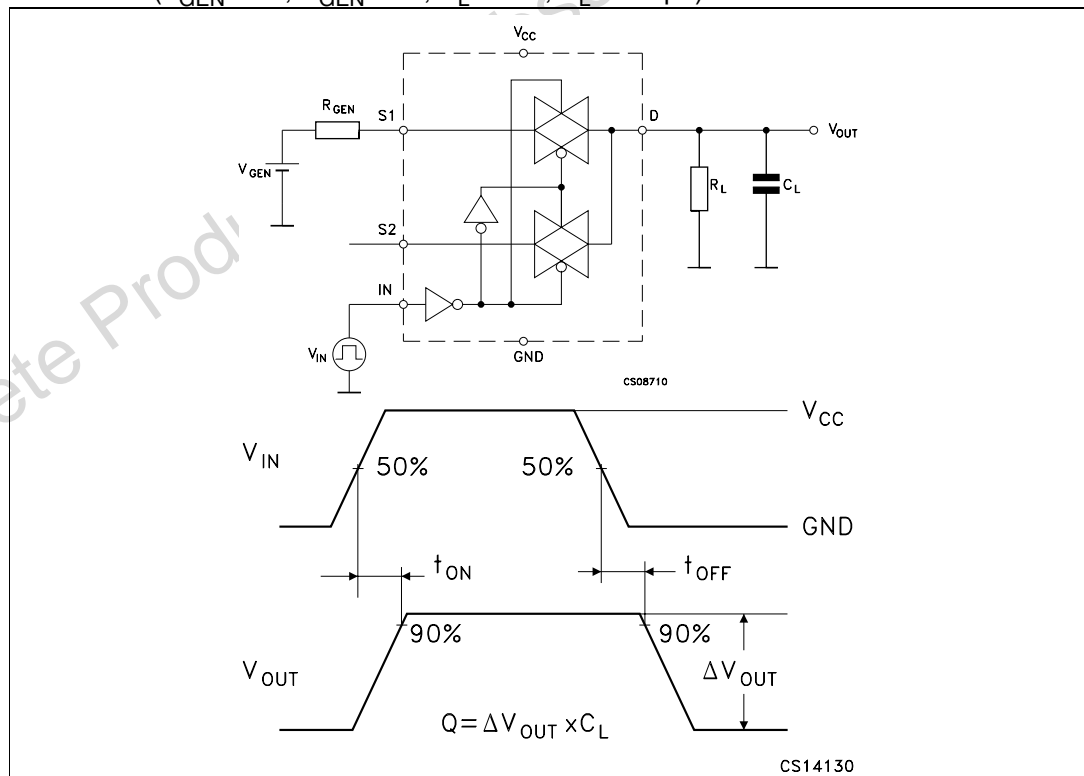
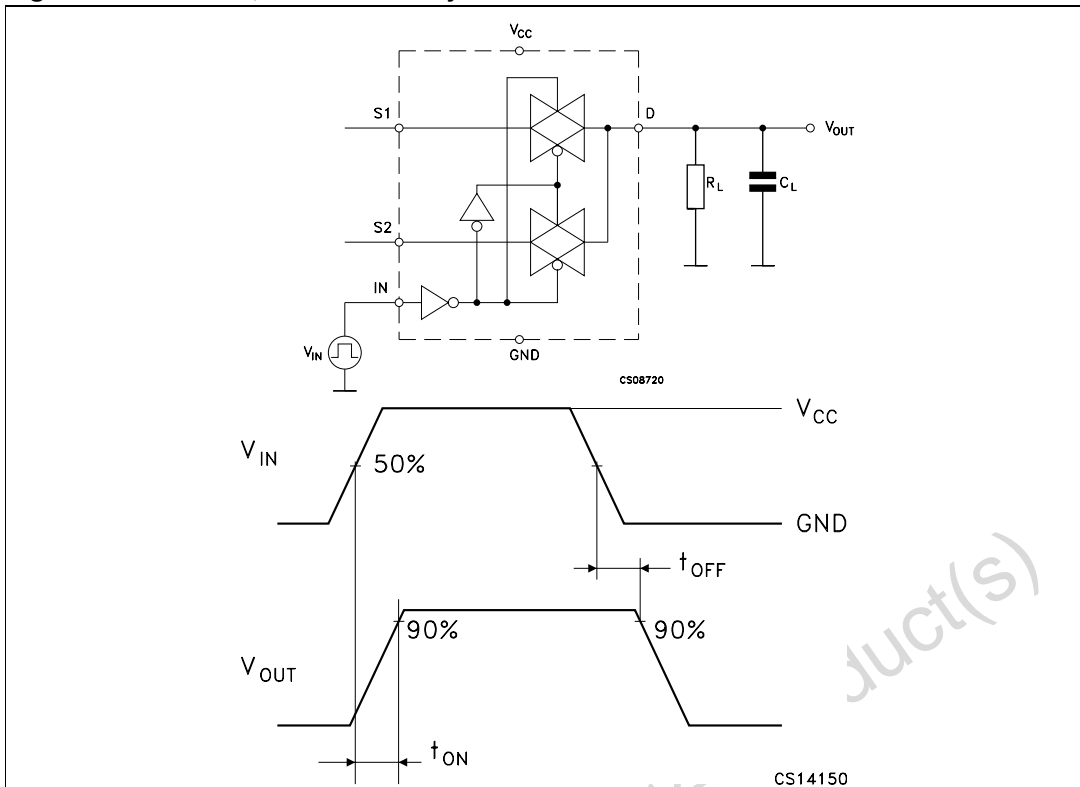

Figure 11. Turn ON, Turn OFF delay time



Obsolete Product(s) - Obsolete Product(s)

5 Package mechanical data

In order to meet environmental requirements, ST offers these devices in ECOPACK® packages. These packages have a Lead-free second level interconnect. The category of second level interconnect is marked on the package and on the inner box label, in compliance with JEDEC Standard JESD97. The maximum ratings related to soldering conditions are also marked on the inner box label. ECOPACK is an ST trademark. ECOPACK specifications are available at: www.st.com

Obsolete Product(s) - Obsolete Product(s)

Table 8. DFN10L (2.5mm x 1.3mm) Mechanical data

Dim.	mm.			inch		
	Min.	Typ.	Max.	Min.	Typ.	Max.
A	0.50	0.55	0.60	19.7	21.7	23.6
A1	0	0.02	0.05	0	0.8	2.0
b	0.18	0.23	0.30	7.1	9.1	11.8
D	2.40	2.50	2.60	94.5	98.4	102.4
E	1.30	1.40	1.50	51.2	55.1	59.1
e		0.50			19.7	
K	0.20			7.9		
L	0.45	0.50	0.55	17.7	19.7	21.6
L1			0.15			5.9

Figure 12. Package dimensions

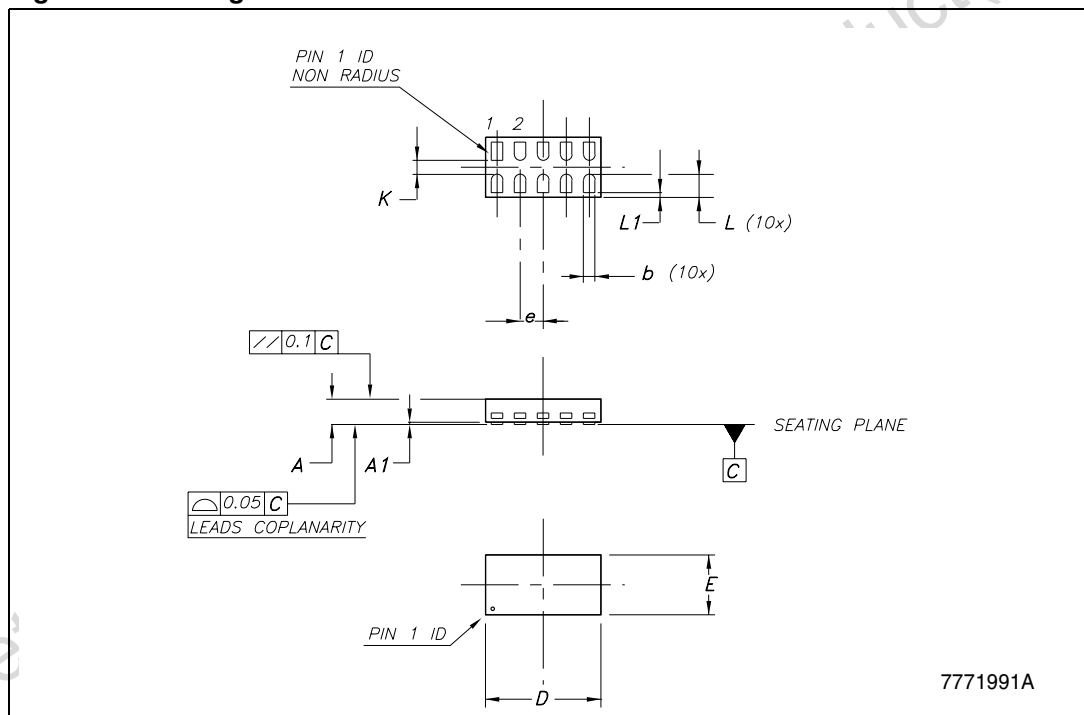

6 Revision history

Table 9. Revision history

Date	Revision	Changes
23-Feb-2006	1	Initial release.
01-Aug-2006	2	Final version, small text changes for entire document.

Obsolete Product(s) - Obsolete Product(s)

Please Read Carefully:

Information in this document is provided solely in connection with ST products. STMicroelectronics NV and its subsidiaries ("ST") reserve the right to make changes, corrections, modifications or improvements, to this document, and the products and services described herein at any time, without notice.

All ST products are sold pursuant to ST's terms and conditions of sale.

Purchasers are solely responsible for the choice, selection and use of the ST products and services described herein, and ST assumes no liability whatsoever relating to the choice, selection or use of the ST products and services described herein.

No license, express or implied, by estoppel or otherwise, to any intellectual property rights is granted under this document. If any part of this document refers to any third party products or services it shall not be deemed a license grant by ST for the use of such third party products or services, or any intellectual property contained therein or considered as a warranty covering the use in any manner whatsoever of such third party products or services or any intellectual property contained therein.

UNLESS OTHERWISE SET FORTH IN ST'S TERMS AND CONDITIONS OF SALE ST DISCLAIMS ANY EXPRESS OR IMPLIED WARRANTY WITH RESPECT TO THE USE AND/OR SALE OF ST PRODUCTS INCLUDING WITHOUT LIMITATION IMPLIED WARRANTIES OF MERCHANTABILITY, FITNESS FOR A PARTICULAR PURPOSE (AND THEIR EQUIVALENTS UNDER THE LAWS OF ANY JURISDICTION), OR INFRINGEMENT OF ANY PATENT, COPYRIGHT OR OTHER INTELLECTUAL PROPERTY RIGHT.

UNLESS EXPRESSLY APPROVED IN WRITING BY AN AUTHORIZED ST REPRESENTATIVE, ST PRODUCTS ARE NOT RECOMMENDED, AUTHORIZED OR WARRANTED FOR USE IN MILITARY, AIR CRAFT, SPACE, LIFE SAVING, OR LIFE SUSTAINING APPLICATIONS, NOR IN PRODUCTS OR SYSTEMS WHERE FAILURE OR MALFUNCTION MAY RESULT IN PERSONAL INJURY, DEATH, OR SEVERE PROPERTY OR ENVIRONMENTAL DAMAGE. ST PRODUCTS WHICH ARE NOT SPECIFIED AS "AUTOMOTIVE GRADE" MAY ONLY BE USED IN AUTOMOTIVE APPLICATIONS AT USER'S OWN RISK.

Resale of ST products with provisions different from the statements and/or technical features set forth in this document shall immediately void any warranty granted by ST for the ST product or service described herein and shall not create or extend in any manner whatsoever, any liability of ST.

ST and the ST logo are trademarks or registered trademarks of ST in various countries.

Information in this document supersedes and replaces all information previously supplied.

The ST logo is a registered trademark of STMicroelectronics. All other names are the property of their respective owners.

© 2006 STMicroelectronics - All rights reserved

STMicroelectronics group of companies

Australia - Belgium - Brazil - Canada - China - Czech Republic - Finland - France - Germany - Hong Kong - India - Israel - Italy - Japan - Malaysia - Malta - Morocco - Singapore - Spain - Sweden - Switzerland - United Kingdom - United States of America

www.st.com