



Chipsmall Limited consists of a professional team with an average of over 10 year of expertise in the distribution of electronic components. Based in Hongkong, we have already established firm and mutual-benefit business relationships with customers from,Europe,America and south Asia,supplying obsolete and hard-to-find components to meet their specific needs.

With the principle of “Quality Parts,Customers Priority,Honest Operation,and Considerate Service”,our business mainly focus on the distribution of electronic components. Line cards we deal with include Microchip,ALPS,ROHM,Xilinx,Pulse,ON,Everlight and Freescale. Main products comprise IC,Modules,Potentiometer,IC Socket,Relay,Connector.Our parts cover such applications as commercial,industrial, and automotives areas.

We are looking forward to setting up business relationship with you and hope to provide you with the best service and solution. Let us make a better world for our industry!



## Contact us

Tel: +86-755-8981 8866 Fax: +86-755-8427 6832

Email & Skype: info@chipsmall.com Web: www.chipsmall.com

Address: A1208, Overseas Decoration Building, #122 Zhenhua RD., Futian, Shenzhen, China



## LOW VOLTAGE 0.5Ω MAX QUAD SPDT SWITCH WITH BREAK-BEFORE-MAKE FEATURE

- HIGH SPEED:  
 $t_{PD} = 1.5\text{ns}$  (TYP.) at  $V_{CC} = 3.0\text{V}$   
 $t_{PD} = 1.5\text{ns}$  (TYP.) at  $V_{CC} = 2.3\text{V}$
- ULTRA LOW POWER DISSIPATION:  
 $I_{CC} = 0.2\mu\text{A}$  (MAX.) at  $T_A = 85^\circ\text{C}$
- LOW "ON" RESISTANCE  $V_{IN}=0\text{V}$ :  
 $R_{ON} = 0.5\Omega$  (MAX.  $T_A = 25^\circ\text{C}$ ) at  $V_{CC} = 2.7\text{V}$   
 $R_{ON} = 0.7\Omega$  (MAX.  $T_A = 25^\circ\text{C}$ ) at  $V_{CC} = 2.3\text{V}$   
 $R_{ON} = 1.5\Omega$  (MAX.  $T_A = 25^\circ\text{C}$ ) at  $V_{CC} = 1.8\text{V}$
- WIDE OPERATING VOLTAGE RANGE:  
 $V_{CC}$  (OPR) = 1.65V to 4.3V SINGLE SUPPLY
- 4.3V TOLERANT AND 1.8V COMPATIBLE THRESHOLD ON DIGITAL CONTROL INPUT at  $V_{CC} = 2.3$  to  $3.0\text{V}$
- LATCH-UP PERFORMANCE EXCEEDS 300mA (JESD 17)

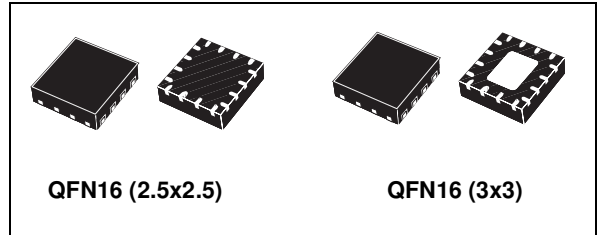

### Order Codes

PACKAGE	T & R
QFN16 (2.5x2.5)	STG3699AUTR
QFN16 (3x3)	STG3699AQTR

### DESCRIPTION

The STG3699A is a high-speed CMOS low voltage quad analog S.P.D.T. (Single Pole/Dual Throw) switch or 2:1 Multiplexer/Demultiplexer Switch fabricated in silicon gate C<sup>2</sup>MOS technology. It is designed to operate from 1.65V to 4.3V, making this device ideal for portable applications.

It offers very low ON-Resistance ( $R_{ON} < 0.5\Omega$ ) at  $V_{CC} = 3.0\text{V}$ . The  $n_{IN}$  inputs are provided to control the switches. The switches  $n_{S1}$  are ON (they are connected to common Ports  $D_n$ ) when the  $n_{IN}$  input is held high and OFF (high impedance state

exists between the two ports) when  $n_{IN}$  is held low; the switches  $n_{S2}$  are ON (they are connected to common Ports  $D_n$ ) when the  $n_{IN}$  input is held low and OFF (high impedance state exists between the two ports) when  $IN$  is held high. Additional key features are fast switching speed, Break-Before-Make delay time and ultra low power consumption. All inputs and outputs are equipped with protection circuits against static discharge, giving them ESD immunity and transient excess voltage. It is available in the commercial temperature range (-40 to 125°C) in QFN16 3x3mm, 2.5x2.5mm.

**Table 1: Pin Connection (top through view)**

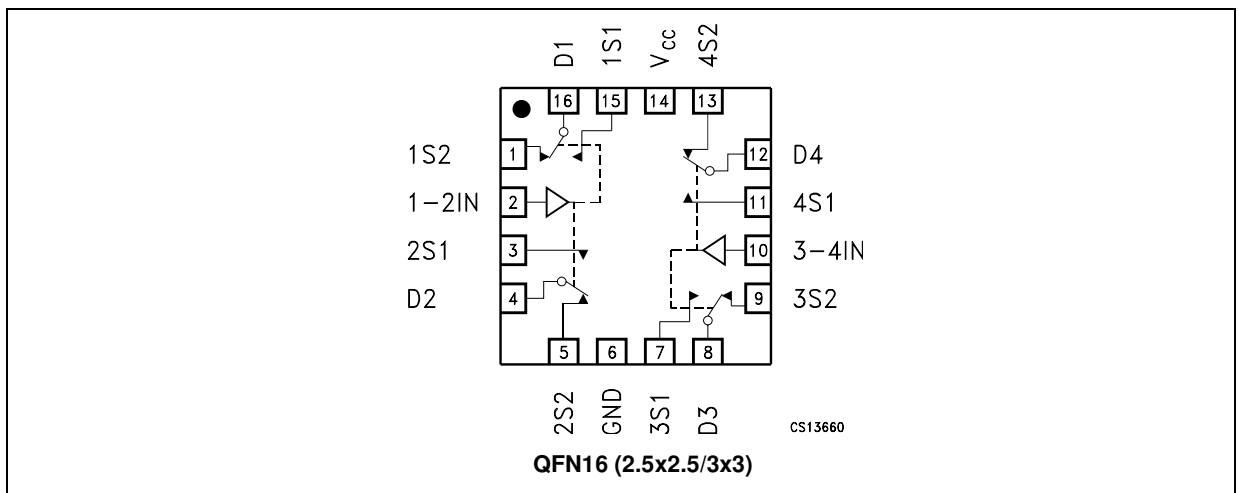

Figure 2: Input Equivalent Circuit

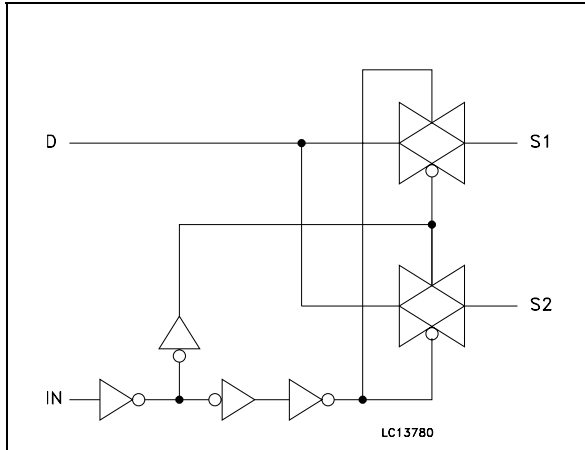

Table 2: Pin Description

PIN <sup>(1)</sup> N°	SYMBOL	NAME AND FUNCTION
15, 3, 7, 11, 1, 5, 9, 13	1S1 to 4S1, 1S2 to 4S2	Independent Channels
16, 4, 8, 12	D1 to D4	Common Channels
2, 10	1-2IN, 3-4IN	Controls
14	V <sub>CC</sub>	Positive Supply Voltage
6	GND	Ground (0V)

1. Exposed pad must be soldered to a floating plane. Do NOT connect to power or ground.

Table 3: Truth Table

1-2IN	3-4IN	ON Switches
L	-	1S2-D1, 2S2-D2
H	-	1S1-D1, 2S1-D2
-	L	3S2-D3, 4S2-D4
-	H	3S1-D3, 4S1-D4

Table 4: Absolute Maximum Ratings

Symbol	Parameter	Value	Unit
V <sub>CC</sub>	Supply Voltage	-0.5 to 5.5	V
V <sub>I</sub>	DC Input Voltage	-0.5 to V <sub>CC</sub> + 0.5	V
V <sub>IC</sub>	DC Control Input Voltage	-0.5 to 5.5	V
V <sub>O</sub>	DC Output Voltage	-0.5 to V <sub>CC</sub> + 0.5	V
I <sub>IKC</sub>	DC Input Diode Current on control pin (V <sub>IN</sub> < 0V)	- 50	mA
I <sub>IK</sub>	DC Input Diode Current (V <sub>IN</sub> < 0V)	± 50	mA
I <sub>OK</sub>	DC Output Diode Current	± 20	mA
I <sub>O</sub>	DC Output Current	± 300	mA
I <sub>OP</sub>	DC Output Current Peak (pulse at 1ms, 10% duty cycle)	± 500	mA
I <sub>CC</sub> or I <sub>GND</sub>	DC V <sub>CC</sub> or Ground Current	± 100	mA
P <sub>D</sub>	Power Dissipation at T <sub>a</sub> = 70°C (1)	1120	mW
T <sub>stg</sub>	Storage Temperature	-65 to 150	°C
T <sub>L</sub>	Lead Temperature (10 sec)	300	°C

Absolute Maximum Ratings are those values beyond which damage to the device may occur. Functional operation under these conditions not implied.

(1) Derate above 70°C: by 18.5mW/°C.

Table 5: Recommended Operating Conditions

Symbol	Parameter	Value	Unit
V <sub>CC</sub>	Supply Voltage (note 1)	1.65 to 4.3	V
V <sub>I</sub>	Input Voltage	0 to V <sub>CC</sub>	V
V <sub>IC</sub>	Control Input Voltage	0 to 4.3	V
V <sub>O</sub>	Output Voltage	0 to V <sub>CC</sub>	V
T <sub>op</sub>	Operating Temperature	-55 to 125	°C
dt/dv	Input Rise and Fall Time Control Input	V <sub>CC</sub> = 1.65V to 2.7V	0 to 20
		V <sub>CC</sub> = 3.0V to 4.3V	0 to 10

1) Truth Table guaranteed: 1.2V to 4.3V.

Table 6: DC Specifications

Symbol	Parameter	Test Conditions		Value						Unit	
		V <sub>CC</sub> (V)		T <sub>A</sub> = 25°C			-40 to 85°C		-55 to 125°C		
				Min.	Typ.	Max.	Min.	Max.	Min.		Max.
V <sub>IH</sub>	High Level Input Voltage	1.65-1.95		0.65V <sub>CC</sub>			0.65V <sub>CC</sub>		0.65V <sub>CC</sub>		V
		2.3-2.5		1.2			1.2		1.2		
		2.7-3.0		1.3			1.3		1.3		
		3.3		1.4			1.4		1.4		
		3.6		1.5			1.5		1.5		
		4.3		1.6			1.6		1.6		
V <sub>IL</sub>	Low Level Input Voltage	1.65-1.95				0.25		0.25		0.25	V
		2.3-2.5				0.25		0.25		0.25	
		2.7-3.0				0.25		0.25		0.25	
		3.3				0.30		0.30		0.30	
		3.6				0.30		0.30		0.30	
		4.3				0.40		0.40		0.40	
R <sub>ON</sub>	Switch ON Resistance	4.3	V <sub>S</sub> =0V to V <sub>CC</sub> I <sub>S</sub> =100mA		0.35	0.45		0.50			Ω
		3.0			0.40	0.50		0.60			
		2.7			0.40	0.50		0.60			
		2.3			0.45	0.70		0.80			
		1.8			0.55	1.5		2.0			
		1.65			0.65	1.5		2.0			
ΔR <sub>ON</sub>	ON Resistance Match between channels (1)	2.7	V <sub>S</sub> @ R <sub>ON</sub> Max I <sub>S</sub> =100mA		0.06						Ω
R <sub>FLAT</sub>	ON Resistance FLATNESS (2)	4.3	V <sub>S</sub> =0V to V <sub>CC</sub> I <sub>S</sub> =100mA		0.15	0.20		0.20			Ω
		3.0			0.15	0.20		0.20			
		2.7			0.15	0.20		0.20			
		2.3			0.20	0.25		0.25			
		1.65			0.30	0.35		0.35			
I <sub>OFF</sub>	OFF State Leakage Current (nSn), (Dn)	4.3	V <sub>S</sub> =0.3 or 4V			±20		±100			nA
I <sub>IN</sub>	Input Leakage Current	0 - 4.3	V <sub>IN</sub> = 0 to 4.3V			±0.1		±1			μA
I <sub>CC</sub>	Quiescent Supply Current	1.65-4.3	V <sub>IN</sub> =V <sub>CC</sub> or GND			±0.05		±0.2		±1	μA
I <sub>CCLV</sub>	Quiescent Supply Current Low Voltage Driving	4.3	V <sub>1-2IN</sub> , V <sub>3-4IN</sub> = 1.65V		±37	±50		±100			μA
			V <sub>1-2IN</sub> , V <sub>3-4IN</sub> = 1.80V		±33	±40		±50			
			V <sub>1-2IN</sub> , V <sub>3-4IN</sub> = 2.60V		±12	±20		±30			

Note 1: ΔR<sub>ON</sub> = R<sub>ON(MAX)</sub> - R<sub>ON(MIN)</sub>.

Note 2: Flatness is defined as the difference between the maximum and minimum value of on-resistance as measured over the specified analog signal ranges.

Table 7: AC Electrical Characteristics ( $C_L = 35\text{pF}$ ,  $R_L = 50\Omega$ ,  $t_r = t_f \leq 5\text{ns}$ )

Symbol	Parameter	Test Condition		Value						Unit	
		$V_{CC}$ (V)		$T_A = 25^\circ\text{C}$			$-40$ to $85^\circ\text{C}$		$-55$ to $125^\circ\text{C}$		
				Min.	Typ.	Max.	Min.	Max.	Min.		Max.
$t_{PLH}$ , $t_{PHL}$	Propagation Delay	1.65-1.95	$V_I = \text{OPEN}$		0.45						ns
		2.3-2.7			0.40						
		3.0-3.3			0.30						
		3.6-4.3			0.30						
$t_{ON}$	TURN-ON time	1.65-1.95	$V_S = 0.8\text{V}$		120						ns
		2.3-2.7	$V_S = 1.5\text{V}$		45	55		65			
		3.0-3.3			42	55		65			
		3.6-4.3			40	55		65			
$t_{OFF}$	TURN-OFF time	1.65-1.95	$V_S = 0.8\text{V}$		22						ns
		2.3-2.7	$V_S = 1.5\text{V}$		18	30		40			
		3.0-3.3			16	30		40			
		3.6-4.3			15	30		40			
$t_D$	Break Before Make Time Delay	1.65-1.95	$C_L = 35\text{pF}$ $R_L = 50\Omega$ $V_S = 1.5\text{V}$		10	80					ns
		2.3-2.7			10	60					
		3.0-3.3			10	55					
		3.6-4.3			10	50					
Q	Charge injection	1.65-1.95	$C_L = 100\text{pF}$		50						pC
		2.3-2.7	$R_L = 1\text{M}\Omega$		40						
		3.0-3.3	$V_{GEN} = 0\text{V}$		35						
		3.6-4.3	$R_{GEN} = 0\Omega$		35						

Table 8: Analog Switch Characteristics ( $C_L = 5\text{pF}$ ,  $R_L = 50\Omega$ ,  $T_A = 25^\circ\text{C}$ )

Symbol	Parameter	Test Condition		Value						Unit	
		$V_{CC}$ (V)		$T_A = 25^\circ\text{C}$			$-40$ to $85^\circ\text{C}$		$-55$ to $125^\circ\text{C}$		
				Min.	Typ.	Max.	Min.	Max.	Min.		Max.
OIRR	Off Isolation (1)	1.65-4.3	$V_S = 1V_{RMS}$ $f = 100\text{KHz}$		-64						dB
Xtalk	Crosstalk	1.65-4.3	$V_S = 1V_{RMS}$ $f = 100\text{KHz}$		-54						dB
THD	Total Harmonic Distortion	2.3-4.3	$R_L = 600\Omega$ $V_{IN} = 2V_{PP}$ $f = 20\text{Hz}$ to $20\text{kHz}$		0.03						%
BW	-3dB Bandwidth	1.65-4.3	$R_L = 50\Omega$		50						MHz
$C_{IN}$	Control Pin Input Capacitance				5						pF
$C_{Sn}$	Sn Port Capacitance	3.3	$f = 1\text{MHz}$		30						
$C_D$	D Port Capacitance when Switch is Enabled	3.3	$f = 1\text{MHz}$		84						

Note 1: Off Isolation =  $20\text{Log}_{10}(V_D/V_S)$ ,  $V_D$  = output.  $V_S$  = input to off switch

Figure 3: ON Resistance

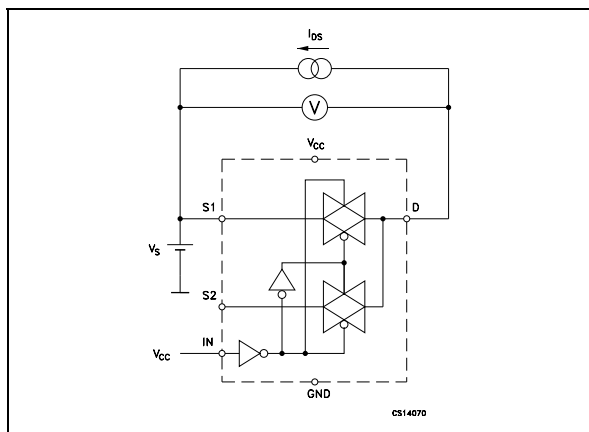

Figure 6: Bandwidth

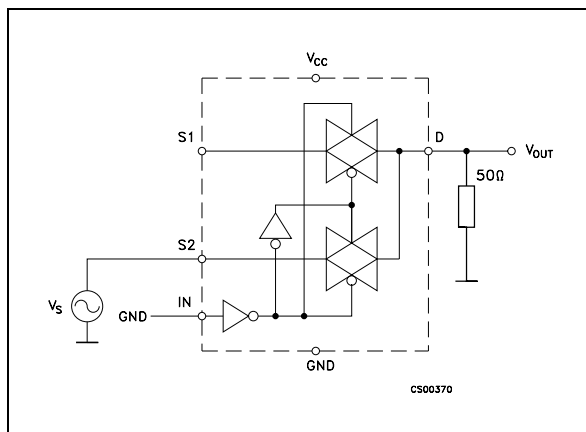

Figure 4: Off Leakage

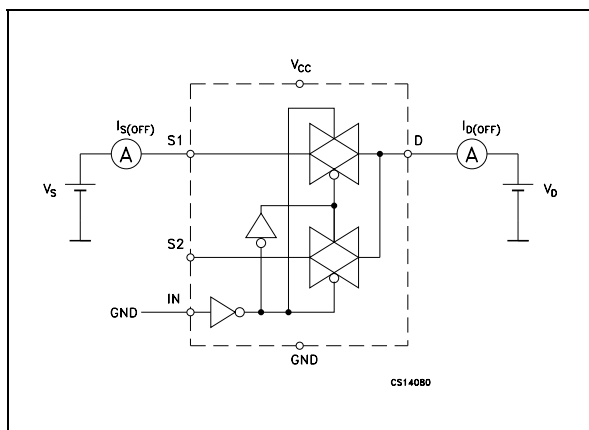

Figure 7: Channel To Channel Crosstalk

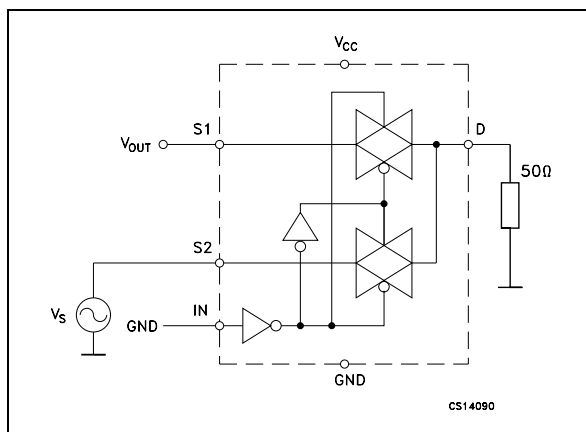

Figure 5: Off Isolation

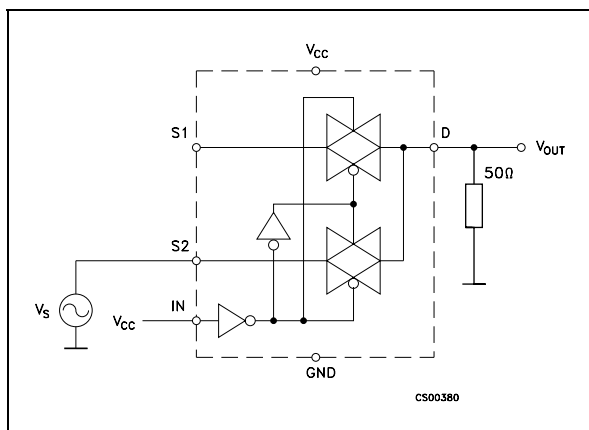
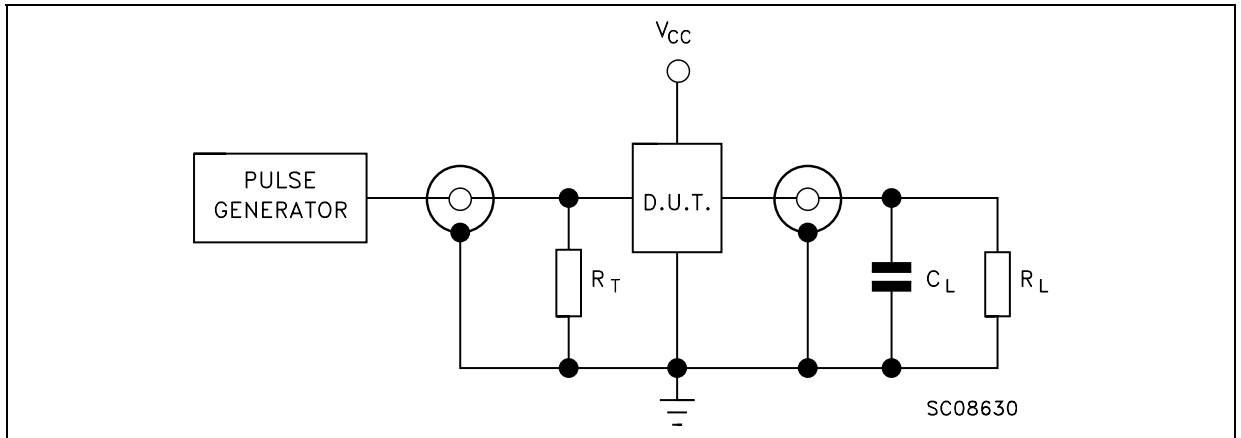

Figure 8: Test Circuit



$C_L = 5/35\text{pF}$  or equivalent (includes jig and probe capacitance)  
 $R_L = 50\Omega$  or equivalent  
 $R_T = Z_{OUT}$  of pulse generator (typically  $50\Omega$ )

Figure 9: Break-before-make Time Delay

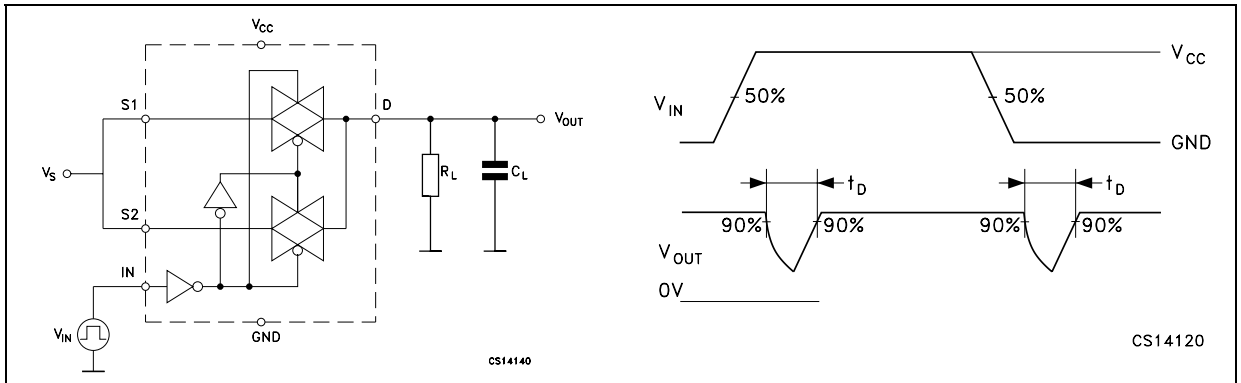

Figure 10: Switching Time and Charge Injection ( $V_{GEN}=0V$ ,  $R_{GEN}=0\Omega$ ,  $R_L=1M\Omega$ ,  $C_L=100\text{pF}$ )

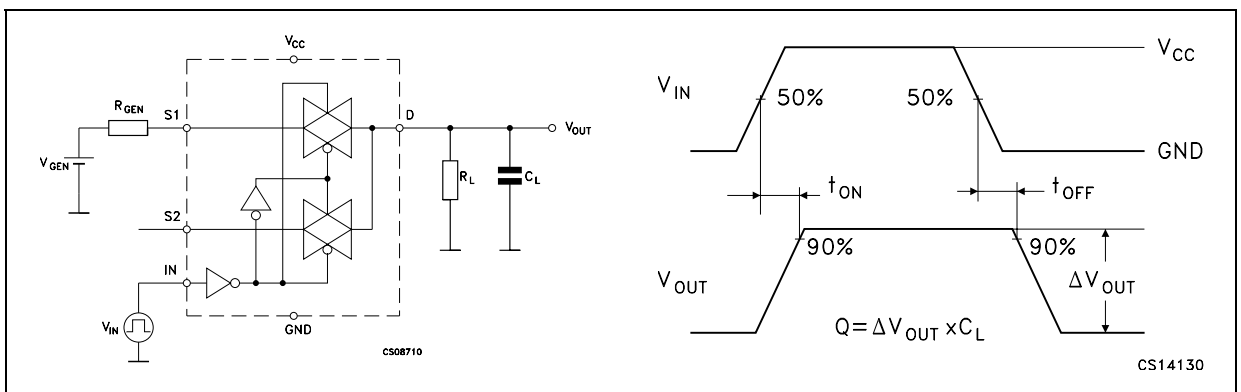
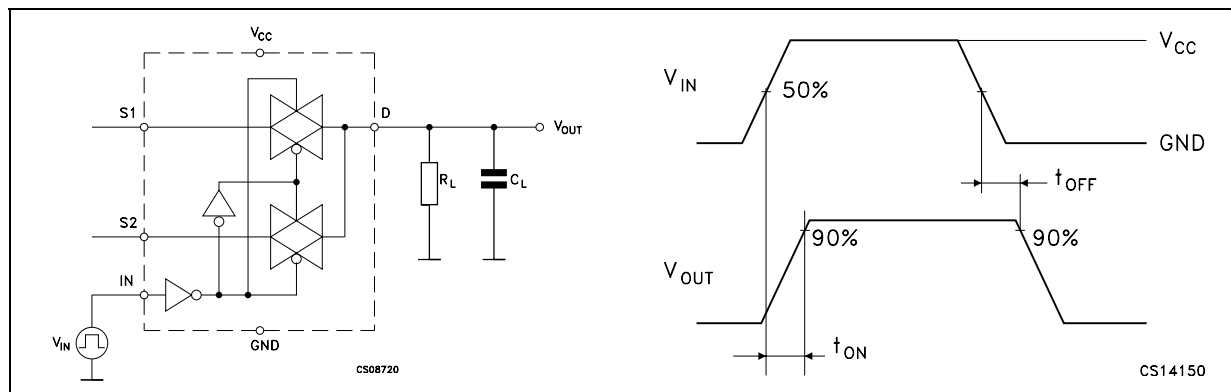

Table 9: Turn On, Turn Off Delay Time





## **Package Mechanical Data**

In order to meet environmental requirements, ST offers these devices in ECOPACK® packages. These packages have a Lead-free second level interconnect . The category of second Level Interconnect is marked on the package and on the inner box label, in compliance with JEDEC Standard JESD97. The maximum ratings related to soldering conditions are also marked on the inner box label. ECOPACK is an ST trademark. ECOPACK specifications are available at: [www.st.com](http://www.st.com).

### QFN16 (2.5x2.5) MECHANICAL DATA

DIM.	mm.			inch		
	MIN.	TYP	MAX.	MIN.	TYP.	MAX.
A	0.50	0.55	0.60	0.020	0.022	0.024
A1		0.02	0.05		0.001	0.002
b	0.15	0.20	0.25	0.006	0.008	0.010
D	2.40	2.50	2.60	0.094	0.098	0.102
E	2.40	2.50	2.60	0.094	0.098	0.102
e		0.40			0.016	
L	0.35	0.40	0.45	0.014	0.016	0.018

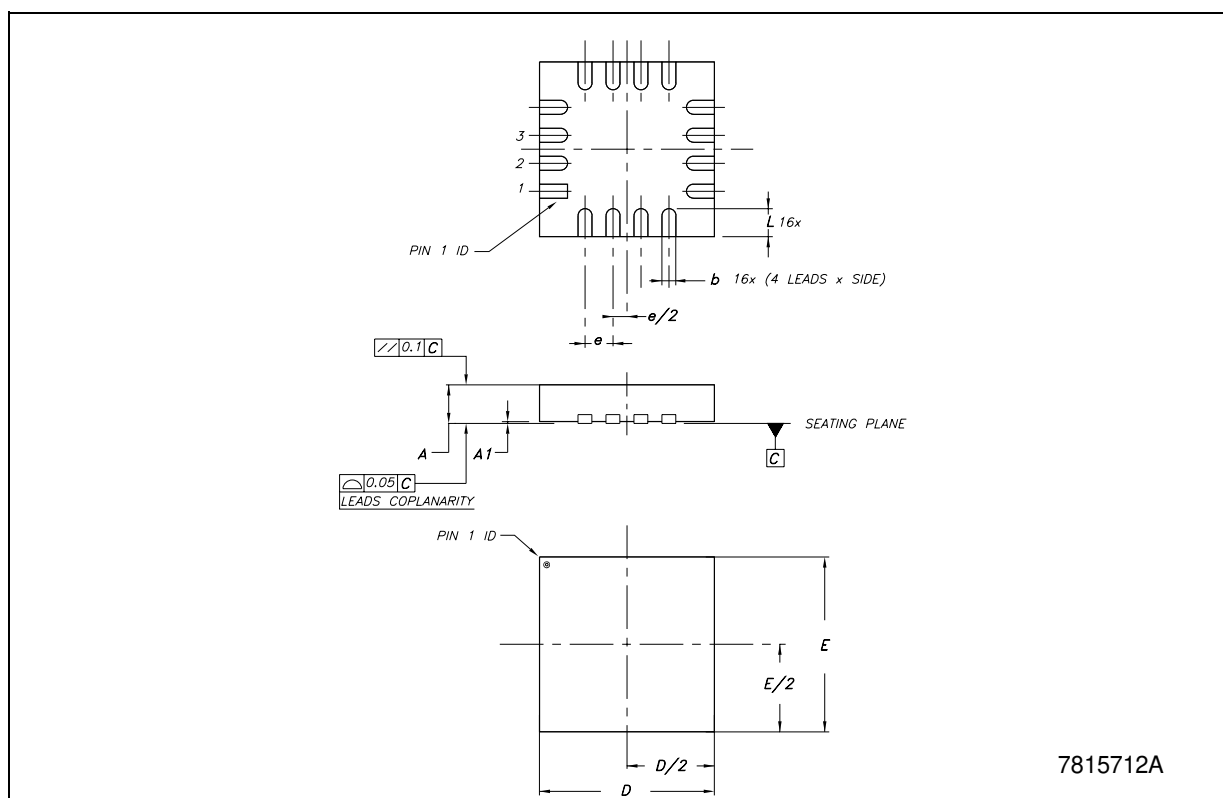

QFN16 (2.5 x 2.5) Tape and Reel

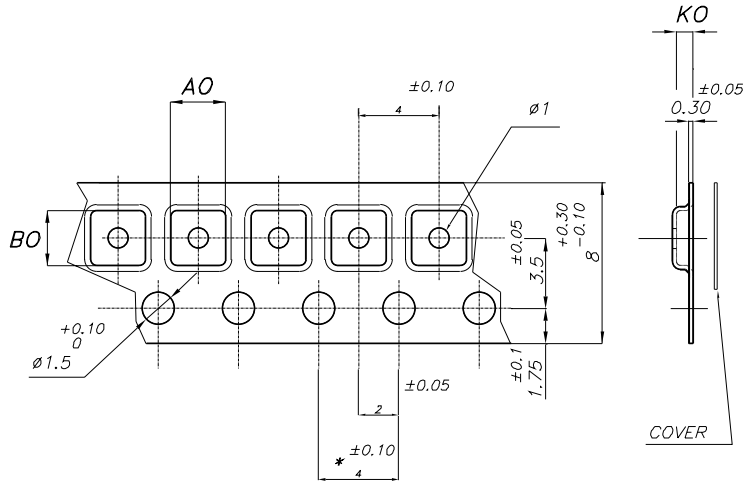

\* - 10 SPROCKET HOLE PITCH CUMULATIVE TOLERANCE ± 0.20

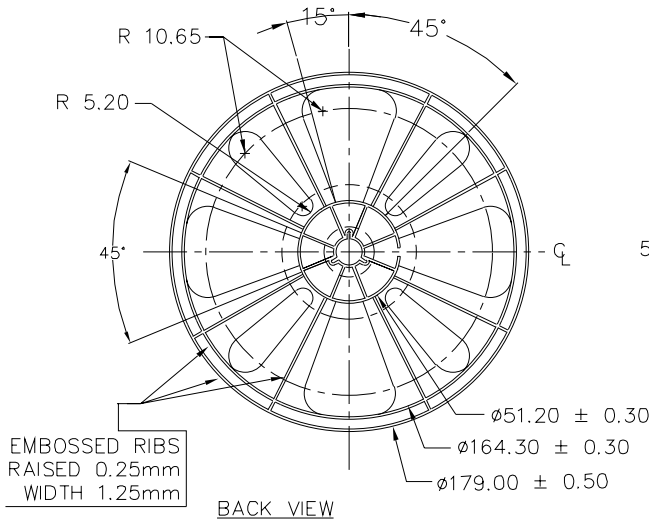

BACK VIEW

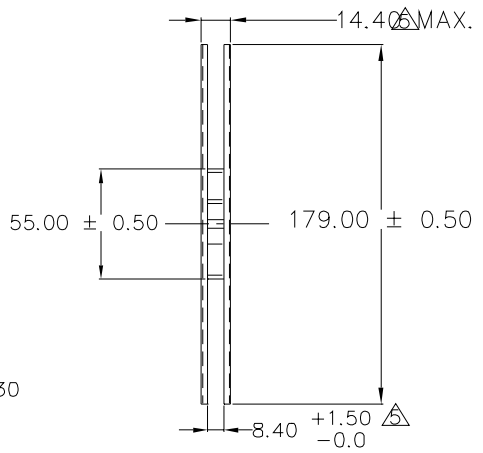

XXX—REPRESENTS SUPPLIER'S  
LOGO OR NAME (OPTION)  
TEXT HEIGHT: 6.25mm HIGH X  
1.6mm WIDE (EMBOSSSED LETTERS)

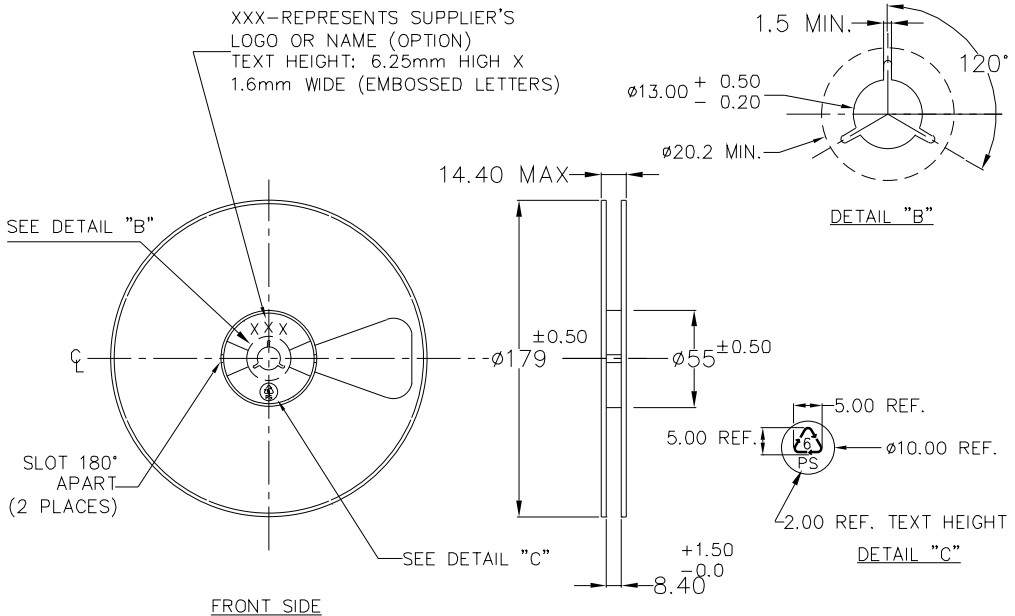

FRONT SIDE

## QFN16 (3x3) MECHANICAL DATA

DIM.	mm.			inch		
	MIN.	TYP.	MAX.	MIN.	TYP.	MAX.
A	0.80	0.90	1.00	0.032	0.035	0.039
A1		0.02	0.05		0.001	0.002
A3		0.20			0.008	
b	0.18	0.25	0.30	0.007	0.010	0.012
D		3.00			0.118	
D2	1.55	1.70	1.80	0.061	0.067	0.071
E		3.00			0.118	
E2	1.55	1.70	1.80	0.061	0.067	0.071
e		0.50			0.020	
K		0.20			0.008	
L	0.30	0.40	0.50	0.012	0.016	0.020
r	0.09			0.006		

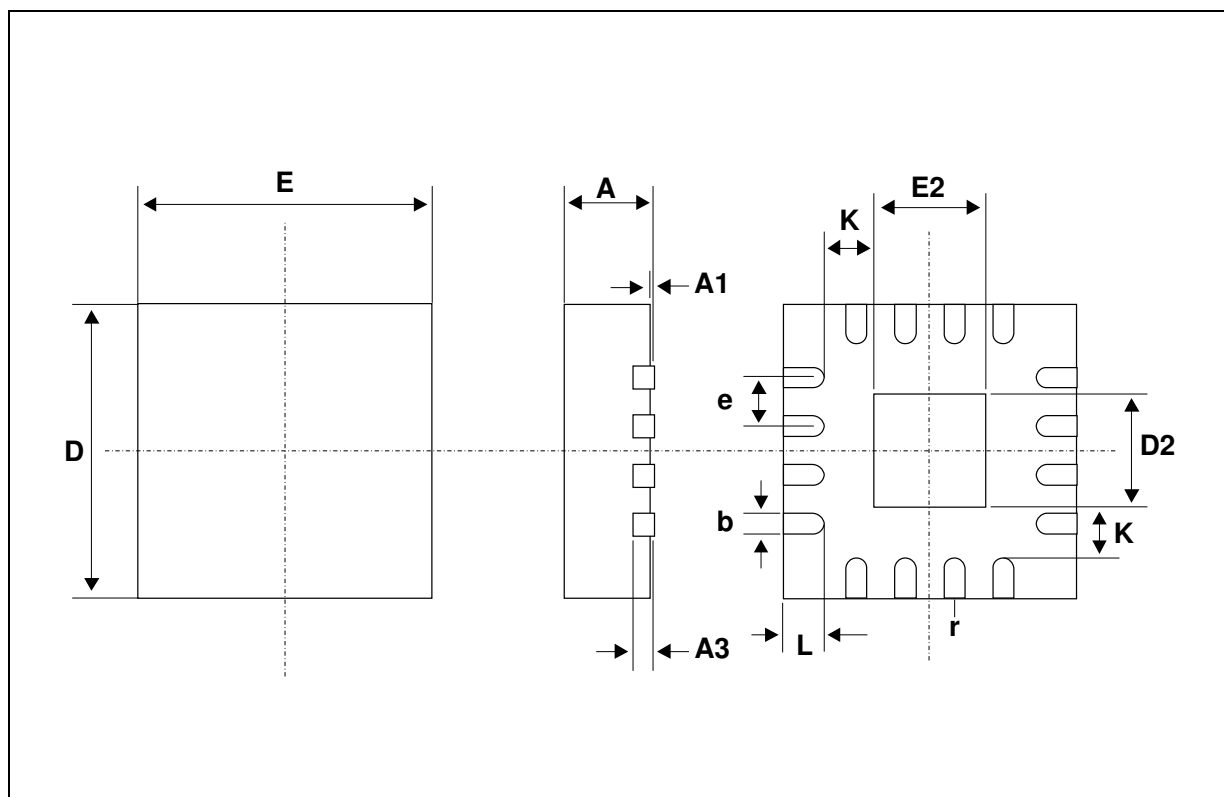

## Tape &amp; Reel QFNxx/DFNxx (3x3) MECHANICAL DATA

DIM.	mm.			inch		
	MIN.	TYP	MAX.	MIN.	TYP.	MAX.
A			330			12.992
C	12.8		13.2	0.504		0.519
D	20.2			0.795		
N	60			2.362		
T			18.4			0.724
Ao		3.3			0.130	
Bo		3.3			0.130	
Ko		1.1			0.043	
Po		4			0.157	
P		8			0.315	

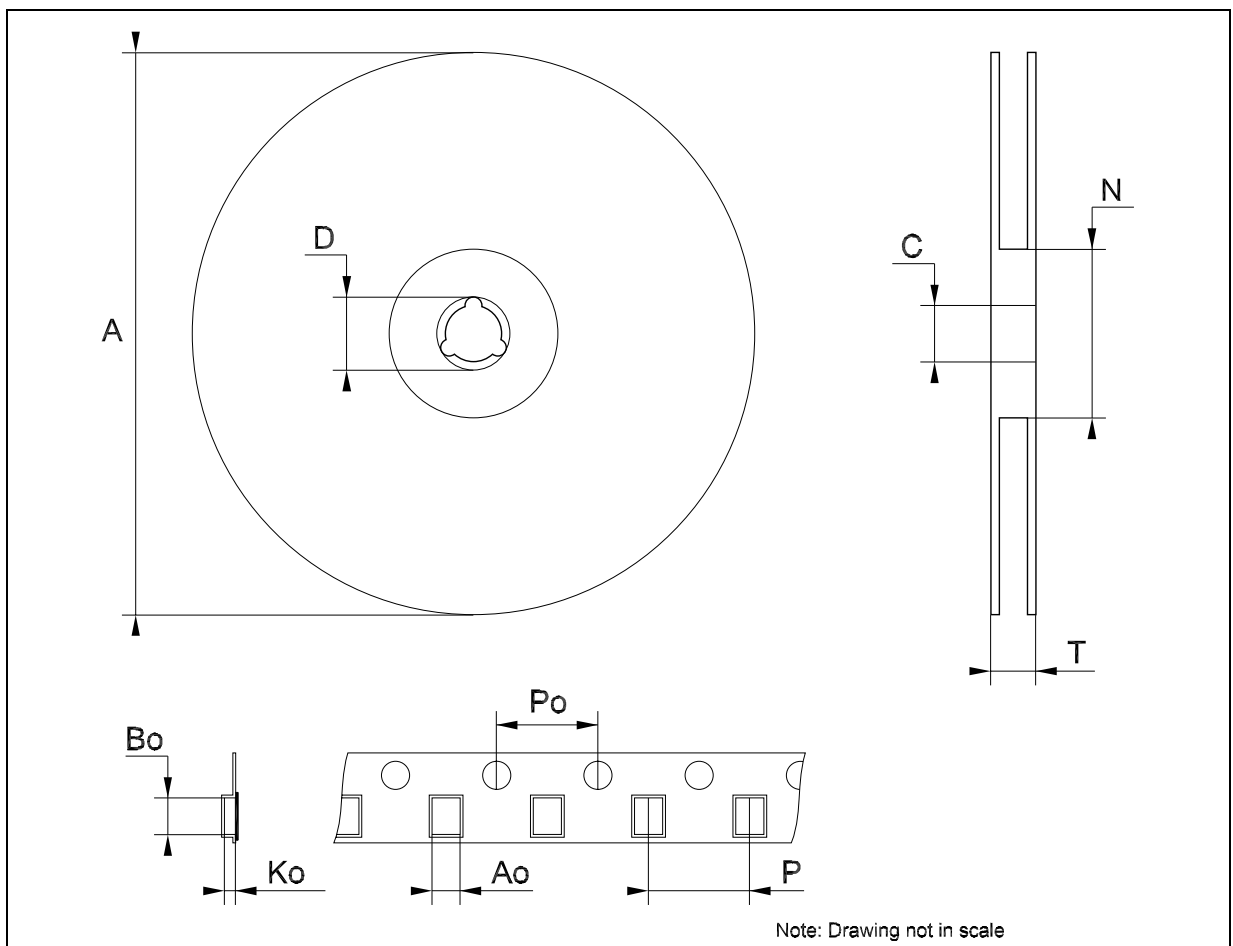

Table 10: Revision History

Date	Revision	Description of Changes
24-Nov-2004	1	First Release.
13-Jan-2005	2	$I_{CCLV}$ is changed on <a href="#">Table 6</a>
23-Mar-2005	3	Table 3 has been updated and $V_{CC}$ is changed on <a href="#">Table 4</a>
31-May-2005	4	Add New Package QFN16 (2.5x2.5).
04-Jul-2005	5	The Q Values on <a href="#">Table 7</a> has been updated.
19-Jul-2005	6	Add New Package QFN16 (2.6x1.8).
03-Aug-2005	7	The $V_{CC}$ and $V_{IC}$ values on <a href="#">Table 4</a> has been updated.
10-Oct-2005	8	Removed all the information about the QFN16L 2.6X1.8 package
21-Nov-2005	9	Modified the label in <a href="#">Table 1</a>
21-Dec-2005	10	Few Updates, added tape and reel QFN16 (2.5 x 2.5)

Information furnished is believed to be accurate and reliable. However, STMicroelectronics assumes no responsibility for the consequences of use of such information nor for any infringement of patents or other rights of third parties which may result from its use. No license is granted by implication or otherwise under any patent or patent rights of STMicroelectronics. Specifications mentioned in this publication are subject to change without notice. This publication supersedes and replaces all information previously supplied. STMicroelectronics products are not authorized for use as critical components in life support devices or systems without express written approval of STMicroelectronics.

The ST logo is a registered trademark of STMicroelectronics

All other names are the property of their respective owners

© 2006 STMicroelectronics - All Rights Reserved

STMicroelectronics group of companies

Australia - Belgium - Brazil - Canada - China - Czech Republic - Finland - France - Germany - Hong Kong - India - Israel - Italy - Japan - Malaysia - Malta - Morocco - Singapore - Spain - Sweden - Switzerland - United Kingdom - United States of America

[www.st.com](http://www.st.com)