



Chipsmall Limited consists of a professional team with an average of over 10 year of expertise in the distribution of electronic components. Based in Hongkong, we have already established firm and mutual-benefit business relationships with customers from,Europe,America and south Asia,supplying obsolete and hard-to-find components to meet their specific needs.

With the principle of “Quality Parts,Customers Priority,Honest Operation,and Considerate Service”,our business mainly focus on the distribution of electronic components. Line cards we deal with include Microchip,ALPS,ROHM,Xilinx,Pulse,ON,Everlight and Freescale. Main products comprise IC,Modules,Potentiometer,IC Socket,Relay,Connector.Our parts cover such applications as commercial,industrial, and automotives areas.

We are looking forward to setting up business relationship with you and hope to provide you with the best service and solution. Let us make a better world for our industry!



Contact us

Tel: +86-755-8981 8866 Fax: +86-755-8427 6832

Email & Skype: info@chipsmall.com Web: www.chipsmall.com

Address: A1208, Overseas Decoration Building, #122 Zhenhua RD., Futian, Shenzhen, China



Galvanically isolated 4 A single gate driver

Datasheet - production data

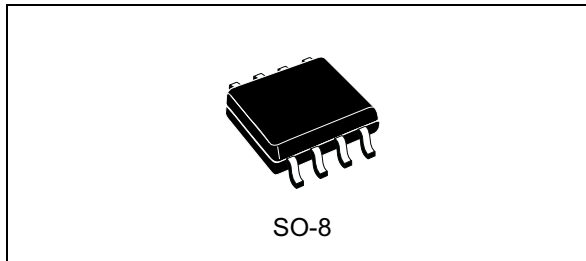

Features

- 1700 V single channel gate driver
- Driver current capability: 4 A sink / source at 25 °C
- dV/dt transient immunity ± 100 V/ns
- Overall input-output propagation delay: 80 ns
- Separate sink and source for easy gate driving configuration
- 4 A Miller clamp dedicated pin
- UVLO function
- Gate driving voltage up to 26 V
- 3.3 V, 5 V TTL/CMOS inputs with hysteresis
- Temperature shutdown protection
- Standby function

Applications

- Motor driver for home appliances, factory automation, industrial drives and fans.
- 600/1200 V inverters
- Battery chargers
- Induction heating
- Welding
- UPS
- Power supply units
- DC-DC converters
- Power factor correction

Description

The STGAP2S is a single gate driver which isolates the gate driving channel from the low voltage control and interface circuitry.

The gate driver is characterized by 4 A capability and rail-to-rail outputs, making the device also suitable for high power inverter applications such as motor drivers in industrial applications.

The device is available in two different configurations. The configuration with separated output pins allows to independently optimize turn-on and turn-off by using dedicated gate resistors. A configuration featuring single output pin and Miller clamp function prevents gate spikes during fast commutations in half-bridge topologies.

Both configurations provide high flexibility and bill of material reduction for external components.

The device integrates protection functions: UVLO and thermal shutdown are included to easily design high reliability systems. Dual input pins allow choosing the control signal polarity and also implementing HW interlocking protection in order to avoid cross-conduction in case of controller malfunction.

The input to output propagation delay results contained within 80 ns, providing high PWM control accuracy.

A standby mode is available in order to reduce idle power consumption.

Contents

1	Block diagram	4
2	Pin description and connection diagram	5
3	Electrical data	6
3.1	Absolute maximum ratings	6
3.2	Thermal data	6
3.3	Recommended operating conditions	6
4	Electrical characteristics	7
5	Functional description	9
5.1	Gate driving power supply and UVLO	9
5.2	Power up, power down and 'safe state'	9
5.3	Control inputs	10
5.4	Miller clamp function	10
5.5	Watchdog	10
5.6	Thermal shutdown protection	10
5.7	Standby function	11
6	Typical application diagram	12
7	Layout	14
7.1	Layout guidelines and considerations	14
7.2	Layout example	15
8	Testing and characterization information	16
9	Package information	17
9.1	SO-8 package information	18
10	Suggested land pattern	19
11	Ordering information	20

12 **Revision history** 21

1 Block diagram

Figure 1. Block diagram - separated outputs option

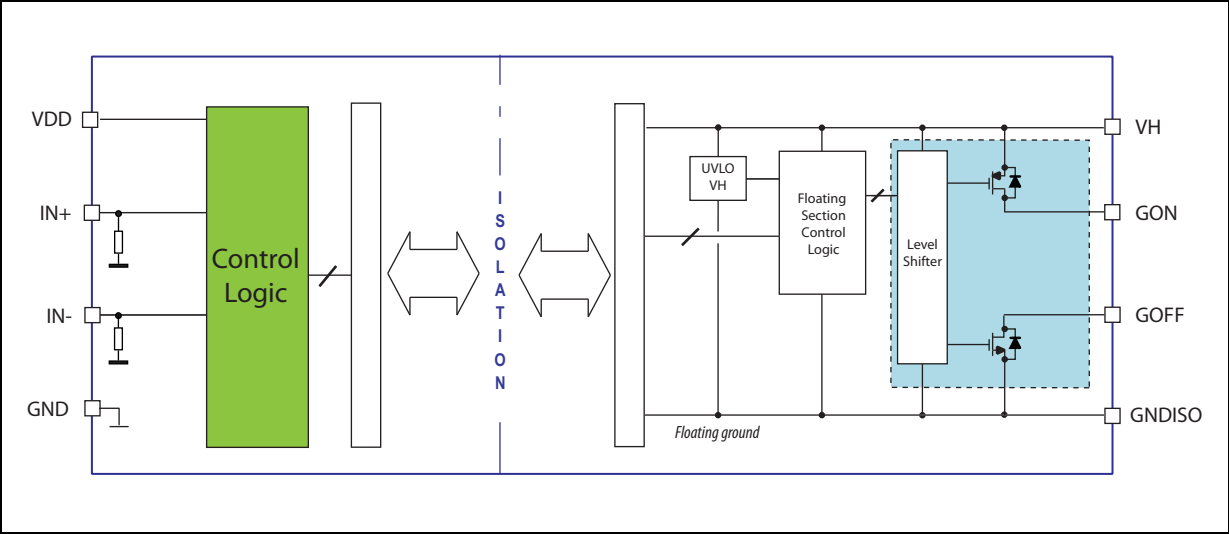
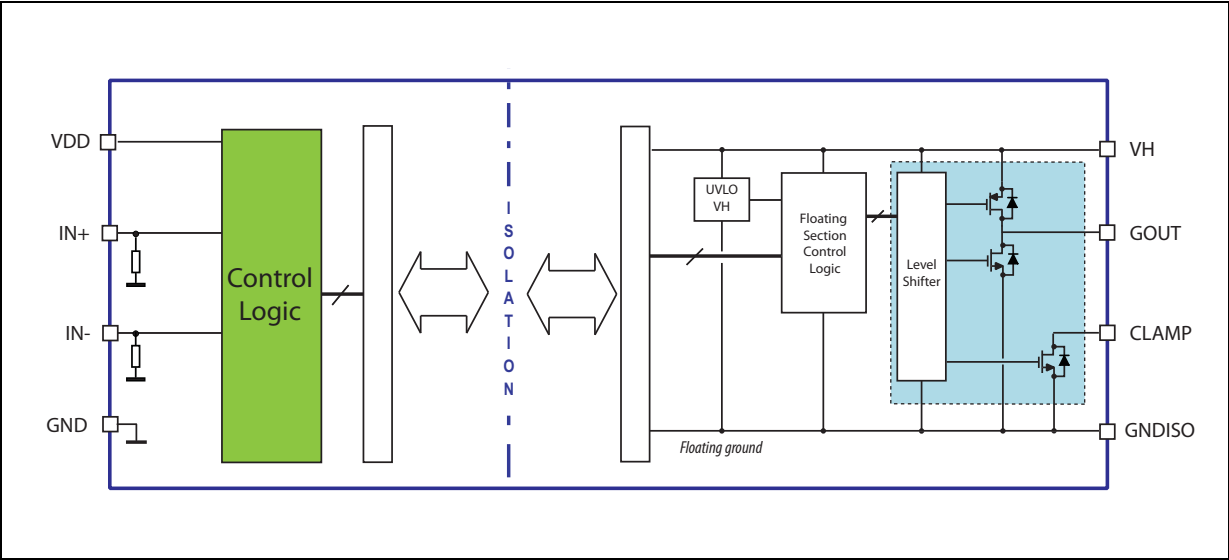

Figure 2. Block diagram - single output and Miller clamp option



2 Pin description and connection diagram

Figure 3. Pin connection (top view), separated outputs option

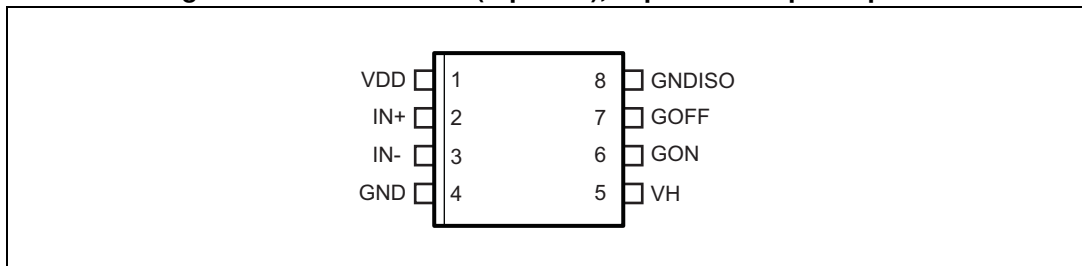

Figure 4. Pin connection (top view), single output and Miller clamp option

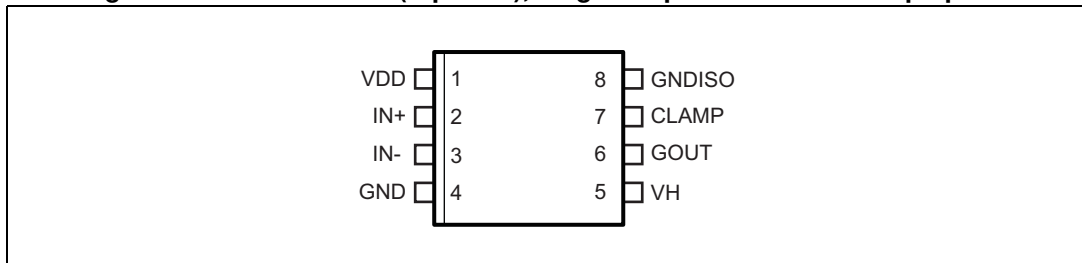

Table 1. Pin description

Pin no.		Pin name	Type	Function
Figure 3	Figure 4			
1	1	VDD	Power supply	Driver logic supply voltage.
2	2	IN+	Logic input	Driver logic input, active high.
3	3	$\overline{\text{IN-}}$	Logic input	Driver logic input, active low.
4	4	GND	Power supply	Driver logic ground.
5	5	VH	Power supply	Gate driving positive voltage supply.
-	6	GOUT	Analog output	Sink/source output.
-	7	CLAMP	Analog output	Active Miller clamp.
6	-	GON	Analog output	Source output.
7	-	GOFF	Analog output	Sink output.
8	8	GNDISO	Power supply	Gate driving Isolated ground.

3 Electrical data

3.1 Absolute maximum ratings

Table 2. Absolute maximum ratings

Symbol	Parameter	Test condition	Min.	Max.	Unit
VDD	Logic supply voltage vs. GND	-	-0.3	6.5	V
V _{LOGIC}	Logic pins voltage vs. GND	-	-0.3	6.5	V
VH	Positive supply voltage (VH vs. GNDISO)	-	-0.3	28	V
V _{OUT}	Voltage on gate driver outputs (GON, GOFF, CLAMP vs. GNDISO)	-	-0.3	VH + 0.3	V
V _{iso}	Input to output isolation voltage (GND vs. GNDISO)	DC or peak	-1700	+1700	V
T _J	Junction temperature	-	-40	150	°C
T _S	Storage temperature	-	-50	150	°C
P _{Din}	Power dissipation input chip	T _A = 25 °C	-	10	mW
P _{Dout}	Power dissipation output chip	T _A = 25 °C	-	850	mW
ESD	HBM (human body model)	-	2		kV

3.2 Thermal data

Table 3. Thermal data

Symbol	Parameter	Package	Value	Unit
R _{th(JA)}	Thermal resistance junction to ambient	SO-8	130	°C/W

3.3 Recommended operating conditions

Table 4. Recommended operating conditions

Symbol	Parameter	Test conditions	Min.	Max.	Unit
VDD	Logic supply voltage vs. GND	-	3	5.5	V
V _{LOGIC}	Logic pins voltage vs. GND	-	0	5.5	V
VH	Positive supply voltage (VH vs. GNDISO)	-	-	26	V
f _{SW}	Maximum switching frequency ⁽¹⁾	-	-	4	MHz
T _{IN}	Pulse width at IN+, IN-	-	100	-	ns
T _J	Operating junction temperature	-	-40	125	°C

1. Actual limit depends on power dissipation and T_J.

4 Electrical characteristics

Table 5. Electrical characteristics
($T_J = 25\text{ °C}$, $V_H = 15\text{ V}$, $V_{DD} = 5\text{ V}$, unless otherwise specified)

Symbol	Pin	Parameter	Test conditions	Min.	Typ.	Max.	Unit
Dynamic characteristics							
t_{Don}	IN+, IN-	Input to output propagation delay ON	-	-	80	100	ns
t_{Doff}	IN+, IN-	Input to output propagation delay OFF	-	-	80	100	ns
t_r	-	Rise time	$C_L = 4.7\text{ nF}$, 10% ÷ 90%	-	30	-	ns
t_f	-	Fall time	$C_L = 4.7\text{ nF}$, 90% ÷ 10%	-	30	-	ns
PWD	-	Pulse width distortion $ t_{Don} - t_{Doff} $	-	-	-	20	ns
$t_{deglitch}$	IN+, IN-	Inputs deglitch filter	-	-	20	40	ns
CMTI ⁽¹⁾	-	Common-mode transient immunity, $ dV_{ISO}/dt $	$V_{CM} = 1500\text{ V}$, see Figure 14 on page 16	100	-	-	V/ns
Supply voltage							
$V_{H_{on}}$	-	VH UVLO turn-on threshold	-	8	9.1	10.5	V
$V_{H_{off}}$	-	VH UVLO turn-off threshold	-	7	8.4	9.5	V
$V_{H_{hyst}}$	-	VH UVLO hysteresis	-	0.5	0.9	1.4	V
$I_{QH_{U}}$	-	VH undervoltage quiescent supply current	$V_H = 4\text{ V}$	-	150	250	μA
I_{QH}	-	VH quiescent supply current	-	-	1.3	2.5	mA
$I_{QH_{SBY}}$	-	Standby VH quiescent supply current	Standby mode	-	400	600	μA
SafeClp	-	GOFF active clamp	$I_{GOFF} = 0.2\text{ A}$; VH floating	-	2	2.5	V
I_{QDD}	-	VDD quiescent supply current	-	-	0.5	0.8	mA
$I_{QDD_{SBY}}$	-	Standby VDD quiescent supply current	Standby mode	-	40	80	μA
Logic inputs							
V_{il}	IN+, IN-	Low level logic threshold voltage	-	$0.29 \cdot V_{DD}$	$1/3 \cdot V_{DD}$	$0.37 \cdot V_{DD}$	V
V_{ih}	IN+, IN-	High level logic threshold voltage	-	$0.62 \cdot V_{DD}$	$2/3 \cdot V_{DD}$	$0.72 \cdot V_{DD}$	V

Table 5. Electrical characteristics
 ($T_J = 25\text{ °C}$, $V_H = 15\text{ V}$, $V_{DD} = 5\text{ V}$, unless otherwise specified) (continued)

Symbol	Pin	Parameter	Test conditions	Min.	Typ.	Max.	Unit
I_{INH}	IN+, IN-	INx logic "1" input bias current	INx = 5 V	33	50	77	μA
I_{INI}	IN+, IN-	INx logic "0" input bias current	INx = GND	-	-	1	μA
R_{pd}	IN+, IN-	Inputs pull-down resistors	INx = 5 V	65	100	150	$\text{k}\Omega$
Driver buffer section							
I_{GON}	-	Source short-circuit current	$T_J = 25\text{ °C}$	-	4	-	A
			$T_J = -40 \div +125\text{ °C}^{(1)}$	3	-	5	
V_{GONH}	-	Source output high level voltage	$I_{GON} = 100\text{ mA}$	VH -0.14	VH -0.11	-	V
R_{GON}	-	Source R_{DS_ON}	$I_{GON} = 100\text{ mA}$	-	1.11	1.4	Ω
I_{GOFF}	-	Sink short-circuit current	$T_J = 25\text{ °C}$	-	4	-	A
			$T_J = -40 \div +125\text{ °C}^{(1)}$	3	-	5.5	
V_{GOFFL}	-	Sink output low level voltage	$I_{GOFF} = 100\text{ mA}$	-	84	95	mV
R_{GOFF}	-	Sink R_{DS_ON}	$I_{GOFF} = 100\text{ mA}$	-	0.84	0.95	Ω
Miller Clamp function (STGAP2SC only)							
$V_{CLAMPth}$	-	CLAMP voltage threshold	V_{CLAMP} vs. GNDISO	1.3	2	2.6	V
I_{CLAMP}	-	CLAMP short-circuit current	$V_{CLAMP} = 15\text{ V}$ $T_J = 25\text{ °C}$ $T_J = -40 \div +125\text{ °C}^{(1)}$	-			A
				-	4	-	
				2	-	5	
V_{CLAMP_L}	-	CLAMP low level output voltage	$I_{CLAMP} = 100\text{ mA}$	-	89	100	mV
R_{CLAMP}	-	CLAMP R_{DS_ON}	$I_{CLAMP} = 100\text{ mA}$	-	0.89	1.00	Ω
Overtemperature protection							
T_{SD}	-	Shutdown temperature	-	170	-	-	$^{\circ}\text{C}$
T_{hys}	-	Temperature hysteresis	-	-	20	-	$^{\circ}\text{C}$
Standby							
t_{STBY}	-	Standby time	See Section 5.3	200	280	350	μs
t_{WUP}	-	Wake-up time	See Section 5.3	10	20	35	μs
t_{awake}	-	Wake-up delay	See Section 5.3	90	140	200	μs
$t_{stbyfilt}$	-	Standby filter	See Section 5.3	200	280	600	ns

1. Characterization data, not tested in production.

5 Functional description

5.1 Gate driving power supply and UVLO

The STGAP2S is a flexible and compact gate driver with 4 A output current and rail-to-rail outputs. The device allows implementation of either unipolar or bipolar gate driving.

Figure 5. Power supply configuration for unipolar and bipolar gate driving

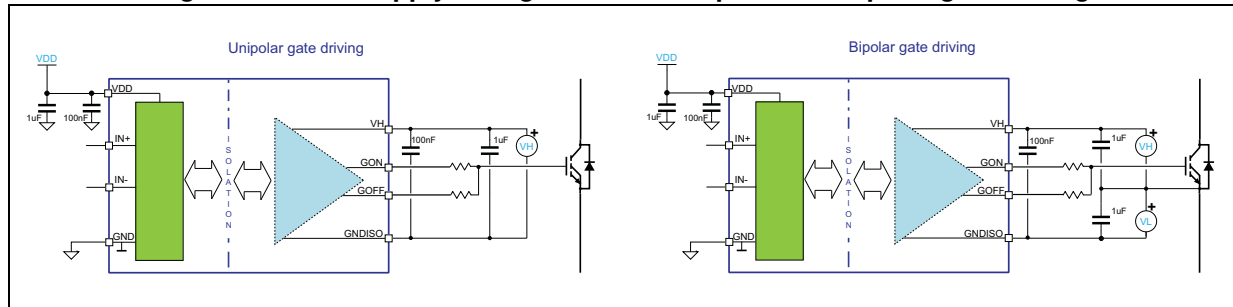

Undervoltage protection is available on VH supply pin. A fixed hysteresis sets the turn-off threshold, thus avoiding intermittent operation.

When VH voltage goes below the VH_{off} threshold, the output buffer goes in “safe state”. When VH voltage reaches the VH_{on} threshold, the device returns to normal operation and sets the output according to actual input pins status.

The VDD and VH supply pins must be properly filtered with local bypass capacitors. The use of capacitors with different values in parallel provides both local storage for impulsive current supply and high-frequency filtering. The best filtering is obtained by using low-ESR SMT ceramic capacitors, which are therefore recommended. A 100 nF ceramic capacitor must be placed as close as possible to each supply pin, and a second bypass capacitor with value in the range between 1 μ F and 10 μ F should be placed close to it.

5.2 Power up, power down and 'safe state'

The following conditions define the “safe state”:

- GOFF = ON state
- GON = high impedance
- CLAMP = ON state (for STGAP2SC)

Such conditions are maintained at power up of the isolated side ($VH < VH_{on}$) and during whole device power down phase ($VH < VH_{off}$), regardless of the value of the input pins.

The device integrates a structure which clamps the driver output to a voltage not higher than SafeClp when VH voltage is not high enough to actively turn the internal GOFF MOSFET on. If VH positive supply pin is floating or not supplied the GOFF pin is therefore clamped to a voltage smaller than SafeClp.

If the supply voltage VDD of the control section of the device is not supplied, the output is put in *safe state*, and remains in such condition until the VDD voltage returns within operative conditions.

After power-up of both isolated and low voltage side the device output state depends on the input pins' status.

5.3 Control inputs

The device is controlled through the IN+ and IN- logic inputs, in accordance to the truth table described in [Table 6](#).

Table 6. Inputs truth table (applicable when device is not in UVLO or “safe state”)

Input pins		Output pins	
IN+	IN-	GON	GOFF
L	L	OFF	ON
H	L	ON	OFF
L	H	OFF	ON
H	H	OFF	ON

A deglitch filter allow the input pins to ignore signals with duration shorter than t_{deglitch} , so preventing noise spikes possibly present in the application from generating unwanted commutations.

5.4 Miller clamp function

The Miller clamp function allows the control of the Miller current during the power stage switching in half-bridge configurations. When the external power transistor is in the OFF state, the driver operates to avoid the induced turn-on phenomenon that may occur when the other switch in the same leg is being turned on, due to the C_{GD} capacitance.

During the turn-off period the gate of the external switch is monitored through the CLAMP pin. The CLAMP switch is activated when gate voltage goes below the voltage threshold. V_{CLAMPth} , thus creating a low impedance path between the switch gate and the GNDISO pin.

5.5 Watchdog

The isolated HV side has a watchdog function in order to identify when it is not able to communicate with LV side, for example because the VDD of the LV side is not supplied. In this case the output of the driver is forced in “safe state” until communication link is properly established again.

5.6 Thermal shutdown protection

The device provides a thermal shutdown protection. When junction temperature reaches the T_{SD} temperature threshold, the device is forced in “safe state”. The device operation is restored as soon as the junction temperature is lower than $T_{SD} - T_{\text{hys}}$.

5.7 Standby function

In order to reduce the power consumption of both control interface and gate driving sides the device can be put in standby mode. In standby mode the quiescent current from VDD and VH supply pins is reduced to I_{QDDSBY} and I_{QHSHBY} respectively, and the output remains in 'safe state' (the output is actively forced low).

The way to enter standby is to keep both IN+ and IN- high ("standby" value) for a time longer than t_{STBY} . During standby the inputs can change from the "stand-by" value.

To exit stand-by, IN+ and IN- must be put in any combination different from the "standby" value for a time longer than $t_{stbyfilt}$, and then in the "standby" value for a time t such that $t_{WUP} < t < t_{STBY}$.

When the input configuration is changed from the "standby" value the output is enabled and set according to inputs state after a time t_{awake} .

Figure 6. Standby state sequences

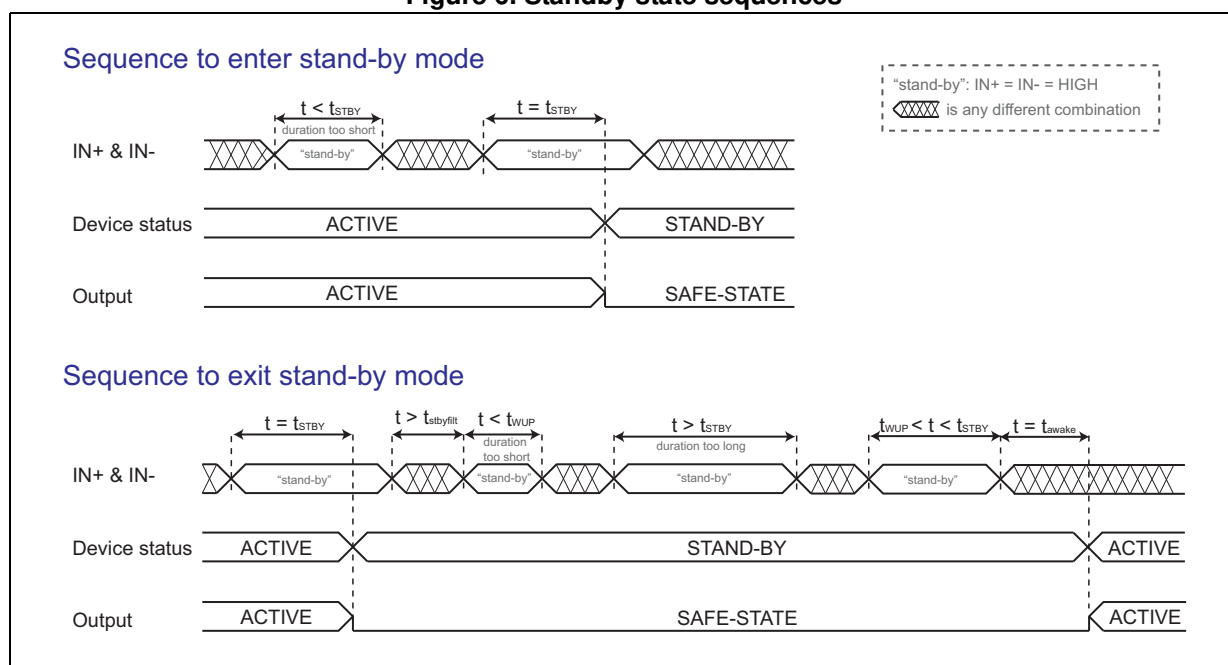

6 Typical application diagram

Figure 7. Typical application diagram - separated outputs

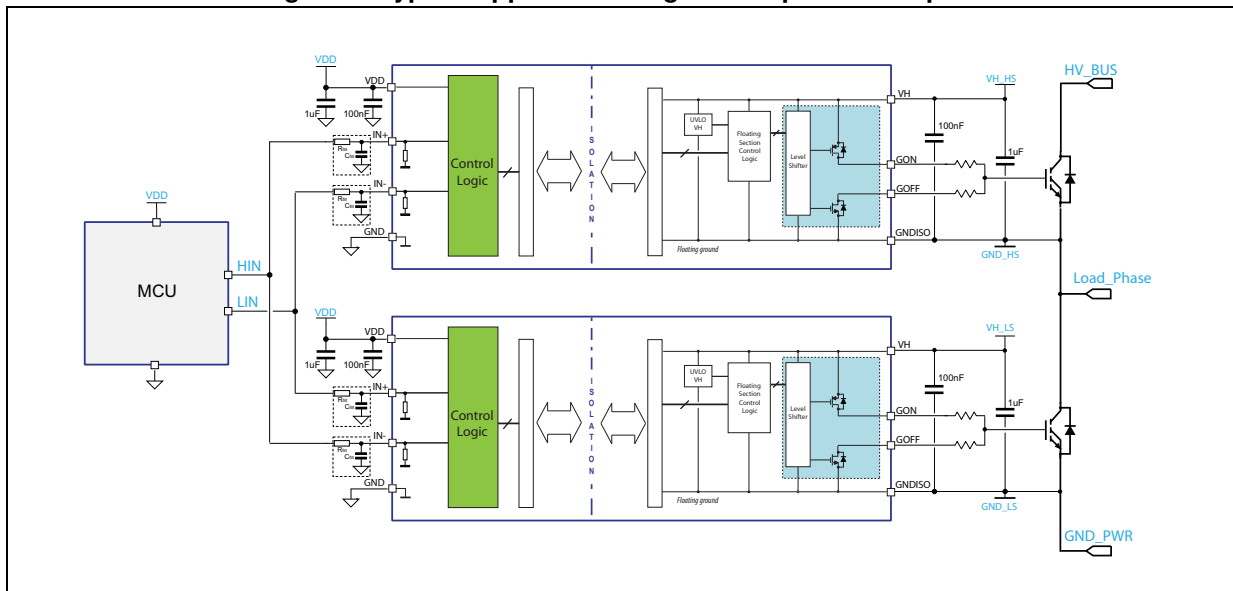

Figure 8. Typical application diagram - separated outputs and negative gate driving

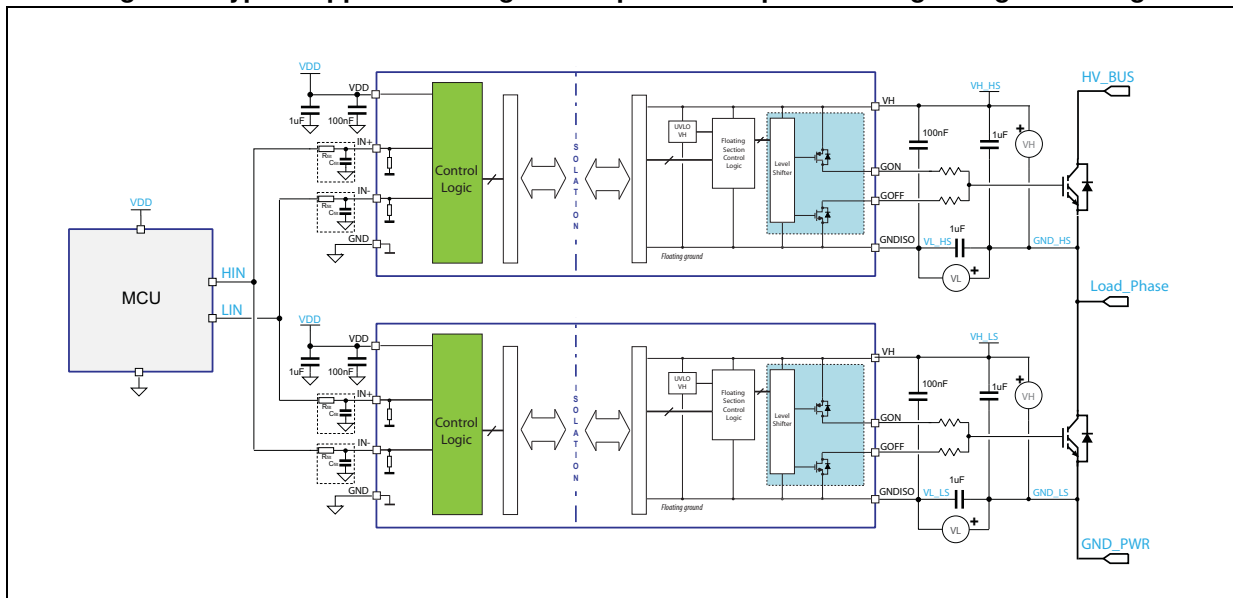

Figure 9. Typical application diagram - Miller clamp

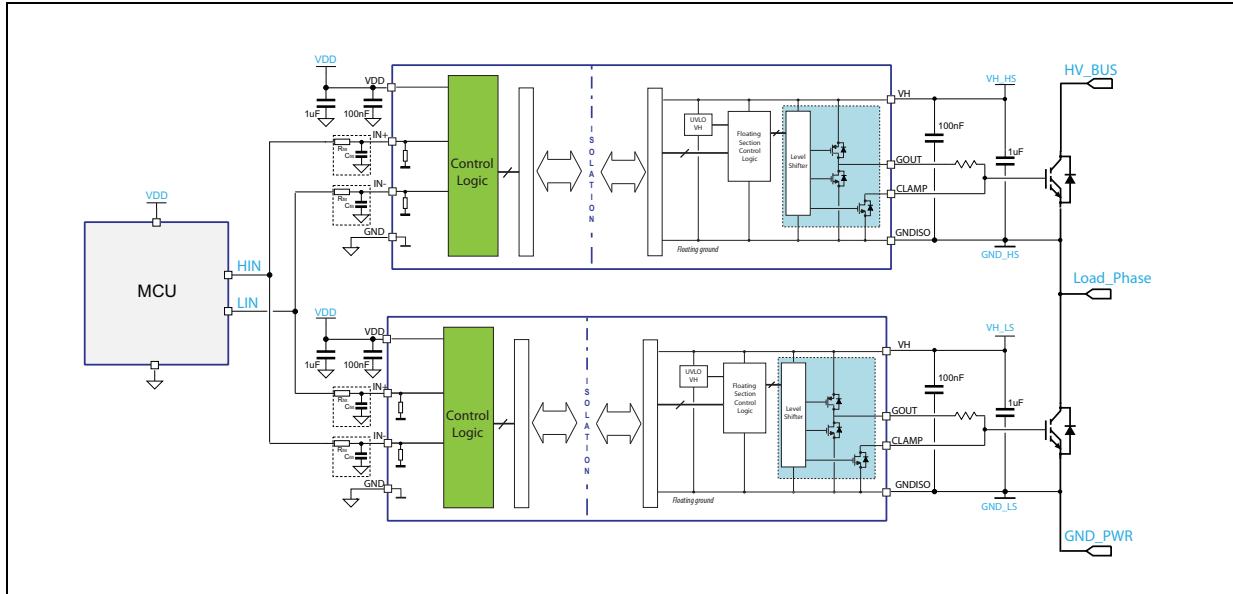
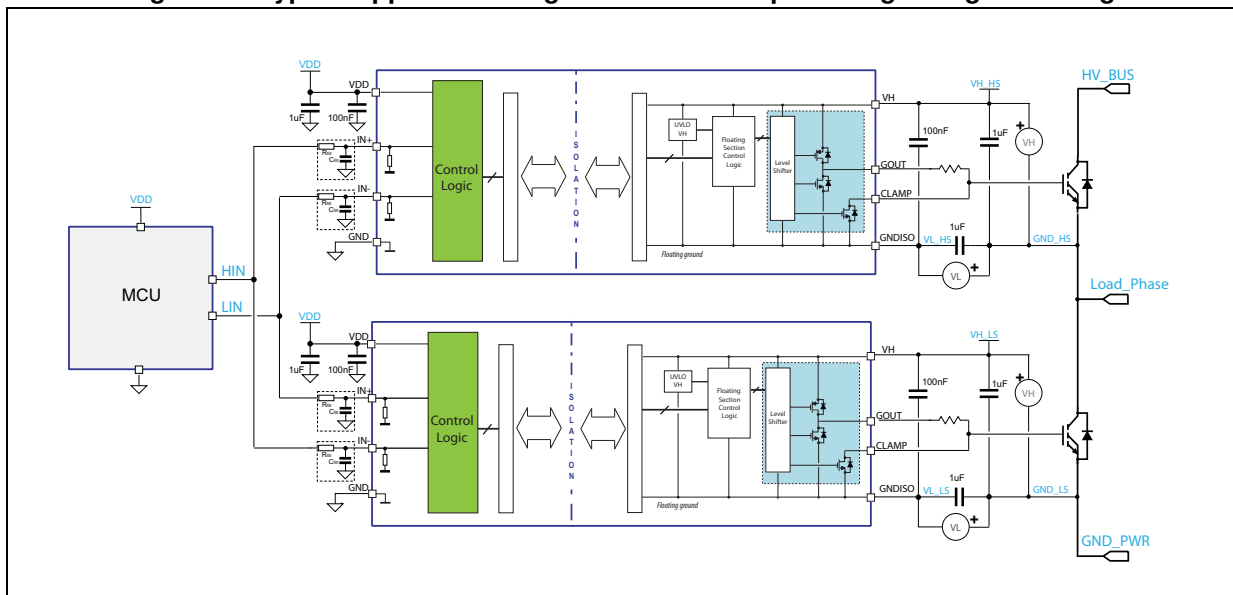

Figure 10. Typical application diagram - Miller clamp and negative gate driving



7 Layout

7.1 Layout guidelines and considerations

In order to optimize the PCB layout, following considerations should be taken into account:

- SMT ceramic capacitors (or different types of low-ESR and low-ESL capacitors) must be placed close to each supply rail pins. A 100 nF capacitor must be placed between VDD and GND and between VH and GNDISO, as close as possible to device pins, in order to filter high-frequency noise and spikes. In order to provide local storage for pulsed current a second capacitor with value in the range between 1 μ F and 10 μ F should also be placed close to the supply pins.
- As a good practice it is suggested to add filtering capacitors close to logic inputs of the device (IN+, IN-), in particular for fast switching or noisy applications.
- The power transistors must be placed as close as possible to the gate driver, so to minimize the gate loop area and inductance that might bring to noise or ringing.
- To avoid degradation of the isolation between the primary and secondary side of the driver, there should not be any trace or conductive area below the driver.
- If the system has multiple layers, it is recommended to connect the VH and GNDISO pins to internal ground or power planes through multiple vias of adequate size. These vias should be located close to the IC pins to maximize thermal conductivity.

7.2 Layout example

An example of STGAP2SC Half-Bridge PCB layout with main signals highlighted by different colors is shown in [Figure 11](#) and [Figure 12](#). It is recommended to follow this example for proper positioning and connection of filtering capacitors.

Figure 11. Top layer traces and copper

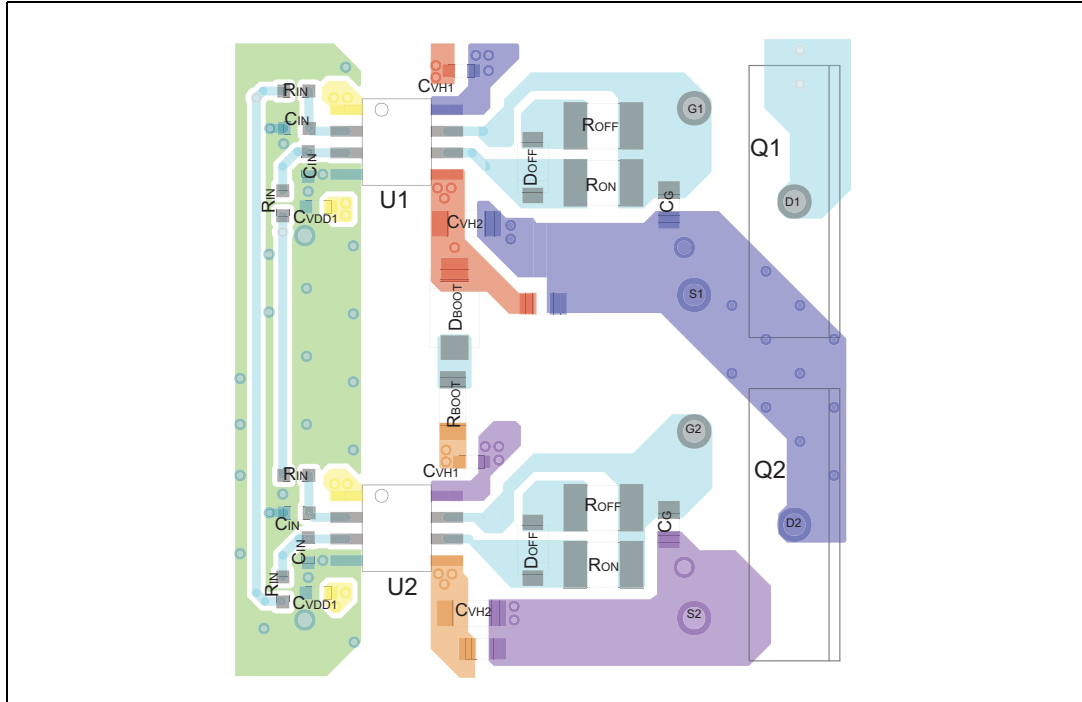
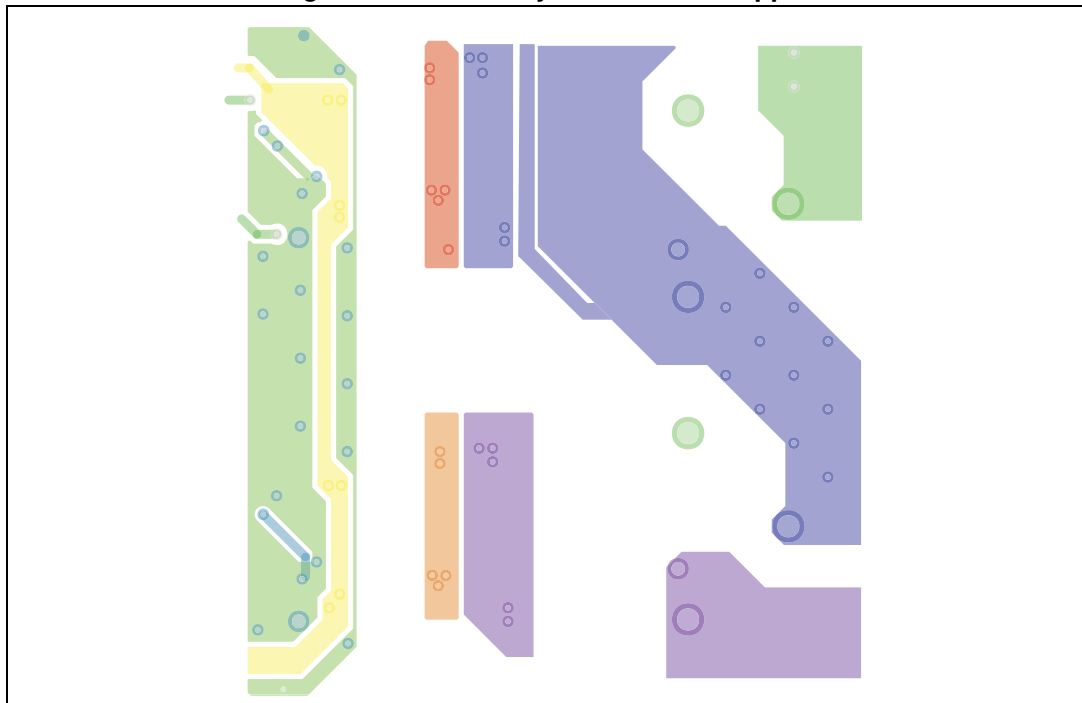

Figure 12. Bottom layer traces and copper



8 Testing and characterization information

Figure 13. Timings definition

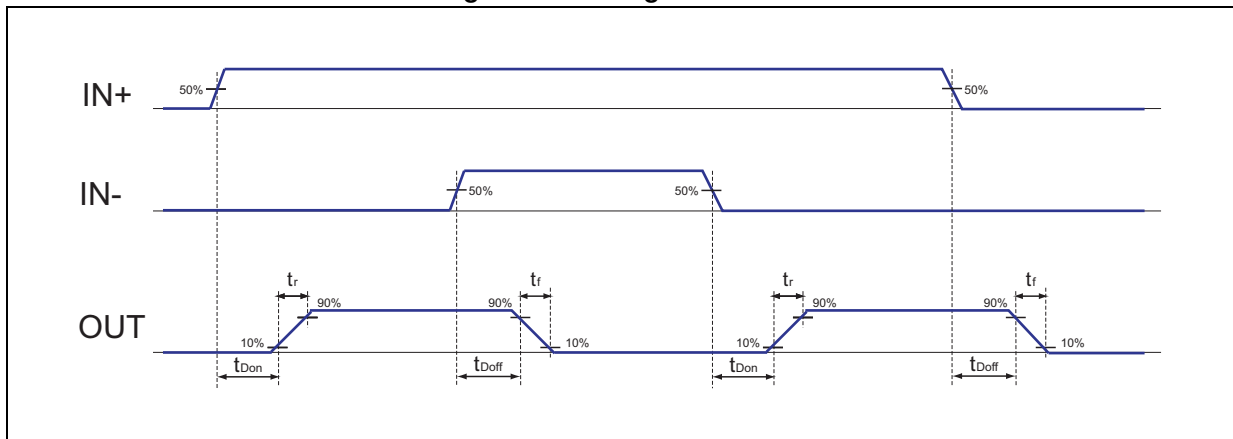
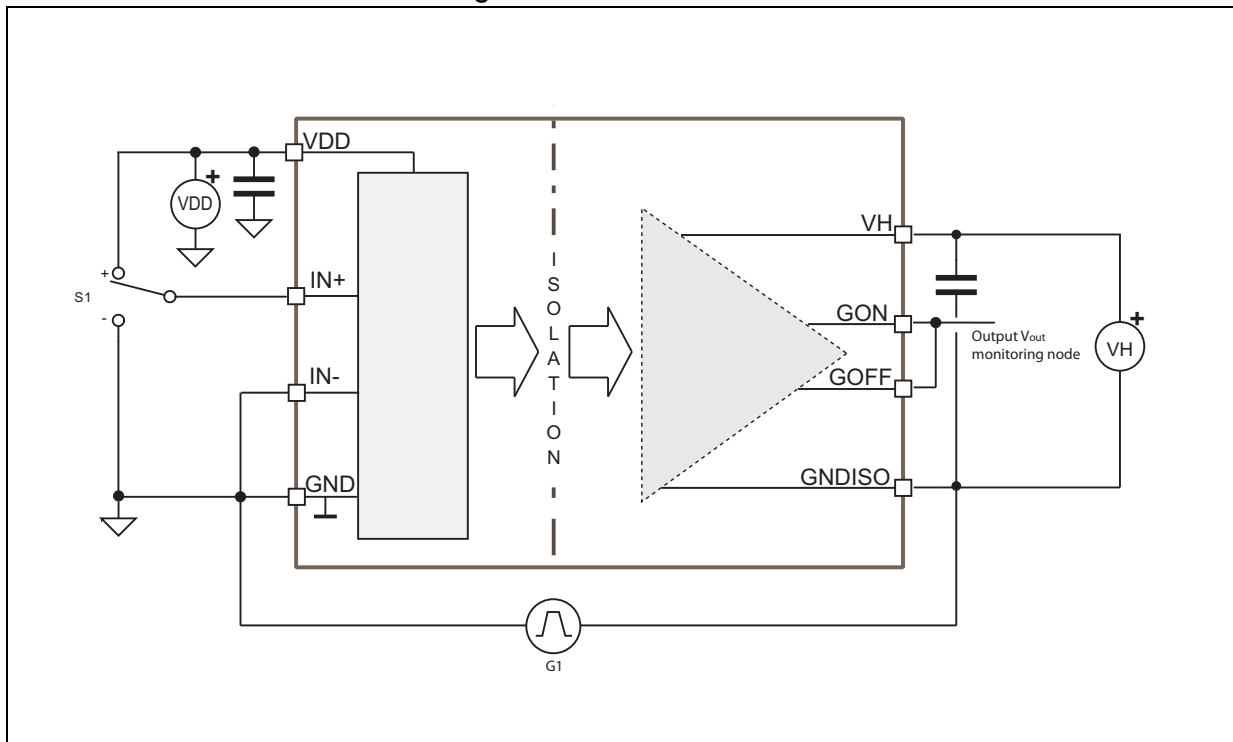

Figure 14. CMTI test circuit



9 Package information

In order to meet environmental requirements, ST offers these devices in different grades of ECOPACK® packages, depending on their level of environmental compliance. ECOPACK® specifications, grade definitions and product status are available at: www.st.com. ECOPACK® is an ST trademark.

9.1 SO-8 package information

Figure 15. SO-8 package outline

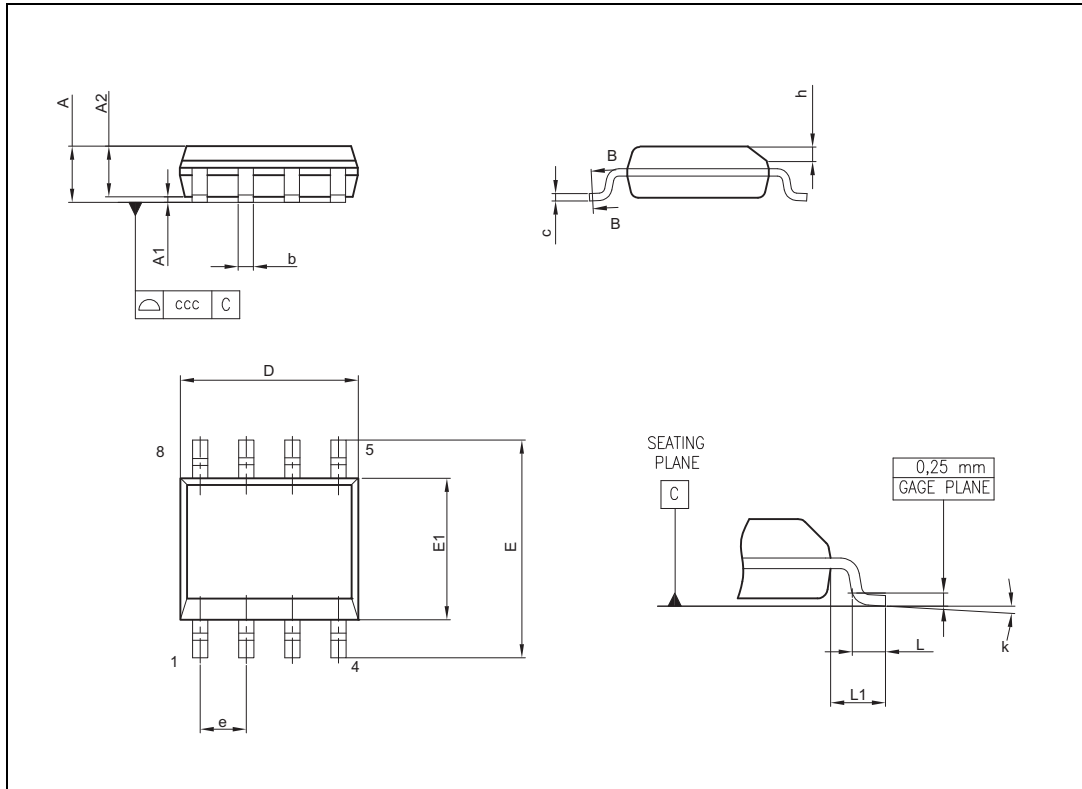
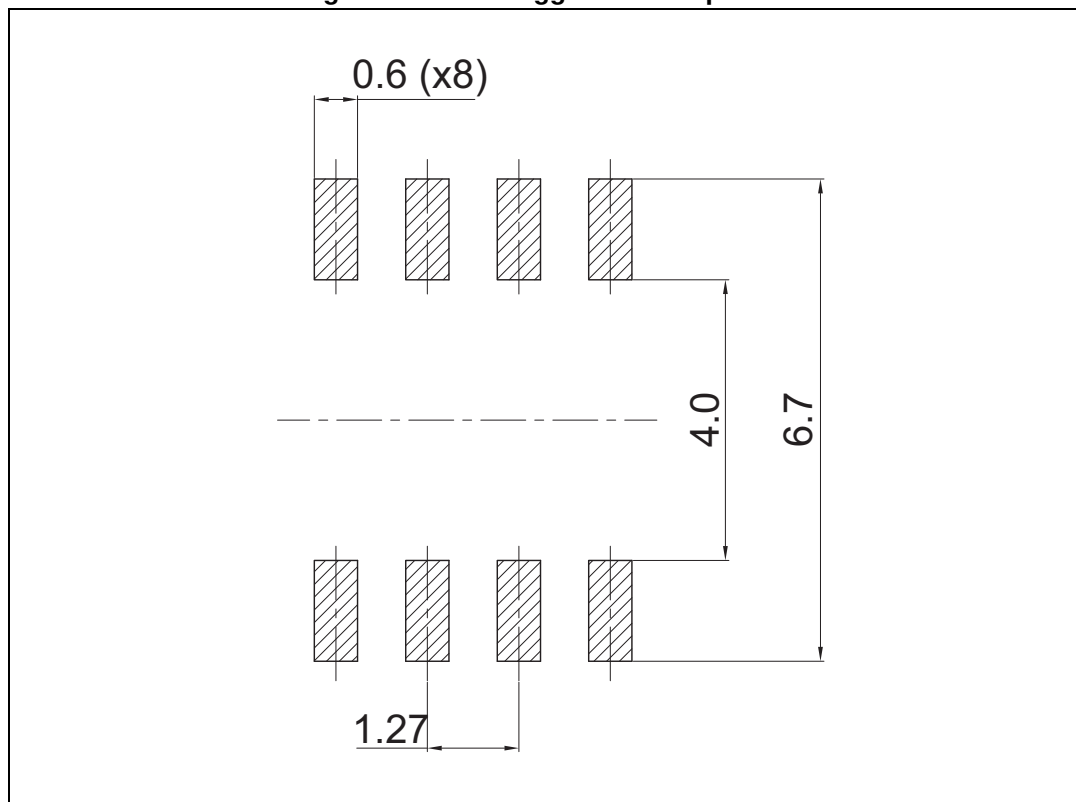

Table 7. SO-8 package mechanical data

Symbol	Dimensions (mm)			Notes
	Min.	Typ.	Max.	
A	-	-	1.75	-
A1	0.10	-	0.25	-
A2	1.25	-	-	-
b	0.28	-	0.48	-
c	0.17	-	0.23	-
D	4.80	4.90	5.00	-
E	5.80	6.00	6.20	-
E1	3.80	3.90	4.00	-
e	-	1.27	-	-
h	0.25	-	0.50	-
L	0.40	-	1.27	-
L1	-	1.04	-	-
k	0	-	8	Degrees
ccc	-	-	0.10	-

10 Suggested land pattern

Figure 16. SO-8 suggested land pattern



11 Ordering information

Table 8. Device summary

Order code	Output configuration	Package marking	Package	Packaging
STGAP2SM	GON-GOFF	GAP2S2	SO-8	Tube
STGAP2SMTR	GON-GOFF	GAP2S2	SO-8	Tape and reel
STGAP2SCM	GOUT-CLAMP	GAP2SC2	SO-8	Tube
STGAP2SCMTR	GOUT-CLAMP	GAP2SC2	SO-8	Tape and reel

12 Revision history

Table 9. Document revision history

Date	Revision	Changes
06-Jun-2018	1	Initial release.

IMPORTANT NOTICE – PLEASE READ CAREFULLY

STMicroelectronics NV and its subsidiaries ("ST") reserve the right to make changes, corrections, enhancements, modifications, and improvements to ST products and/or to this document at any time without notice. Purchasers should obtain the latest relevant information on ST products before placing orders. ST products are sold pursuant to ST's terms and conditions of sale in place at the time of order acknowledgement.

Purchasers are solely responsible for the choice, selection, and use of ST products and ST assumes no liability for application assistance or the design of Purchasers' products.

No license, express or implied, to any intellectual property right is granted by ST herein.

Resale of ST products with provisions different from the information set forth herein shall void any warranty granted by ST for such product.

ST and the ST logo are trademarks of ST. All other product or service names are the property of their respective owners.

Information in this document supersedes and replaces information previously supplied in any prior versions of this document.

© 2018 STMicroelectronics – All rights reserved