



Chipsmall Limited consists of a professional team with an average of over 10 year of expertise in the distribution of electronic components. Based in Hongkong, we have already established firm and mutual-benefit business relationships with customers from,Europe,America and south Asia,supplying obsolete and hard-to-find components to meet their specific needs.

With the principle of “Quality Parts,Customers Priority,Honest Operation,and Considerate Service”,our business mainly focus on the distribution of electronic components. Line cards we deal with include Microchip,ALPS,ROHM,Xilinx,Pulse,ON,Everlight and Freescale. Main products comprise IC,Modules,Potentiometer,IC Socket,Relay,Connector.Our parts cover such applications as commercial,industrial, and automotives areas.

We are looking forward to setting up business relationship with you and hope to provide you with the best service and solution. Let us make a better world for our industry!



## Contact us

Tel: +86-755-8981 8866 Fax: +86-755-8427 6832

Email & Skype: info@chipsmall.com Web: www.chipsmall.com

Address: A1208, Overseas Decoration Building, #122 Zhenhua RD., Futian, Shenzhen, China





# STGP3NB60F - STGD3NB60F

## STGP3NB60FD-STGF3NB60FD-STGB3NB60FD

N-CHANNEL 3A - 600V - TO-220/TO-220FP/DPAK/D<sup>2</sup>PAK

PowerMESH™ IGBT

TYPE	V <sub>CES</sub>	V <sub>CE(sat)</sub> (Typ) @125°C	I <sub>c</sub> @125°C
STGP3NB60F	600 V	< 2.4 V	3 A
STGD3NB60F	600 V	< 2.4 V	3 A
STGP3NB60FD	600 V	< 2.4 V	3 A
STGF3NB60FD	600 V	< 2.4 V	3 A
STGB3NB60FD	600 V	< 2.4 V	3 A

- HIGH INPUT IMPEDANCE (VOLTAGE DRIVEN)
- LOW ON-VOLTAGE DROP (V<sub>cesat</sub>)
- LOW GATE CHARGE
- HIGH CURRENT CAPABILITY
- OFF LOSSES INCLUDE TAIL CURRENT
- HIGH FREQUENCY OPERATION
- SHORT CIRCUIT RATED

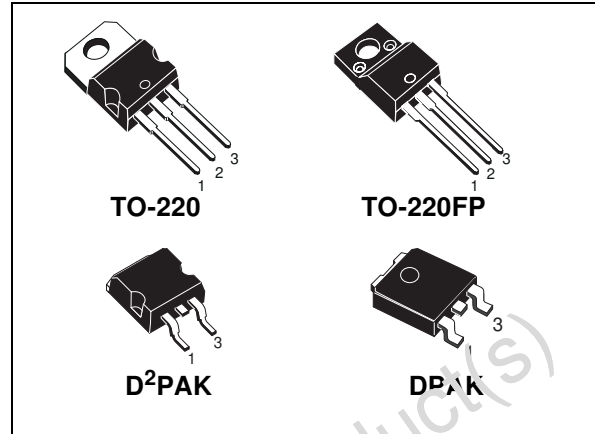

### DESCRIPTION

Using the latest high voltage technology based on a patented strip layout, STMicroelectronics has designed an advanced family of IGBTs, the PowerMESH™ IGBTs, with outstanding performances. The suffix "F" identifies a family optimized to achieve very low switching times for frequency applications (<40 KHz)

### APPLICATIONS

- MOTOR CONTROLS
- SMPS AND PFC IN BOTH HARD SWITCHING AND RESONANT TOPOLOGIES

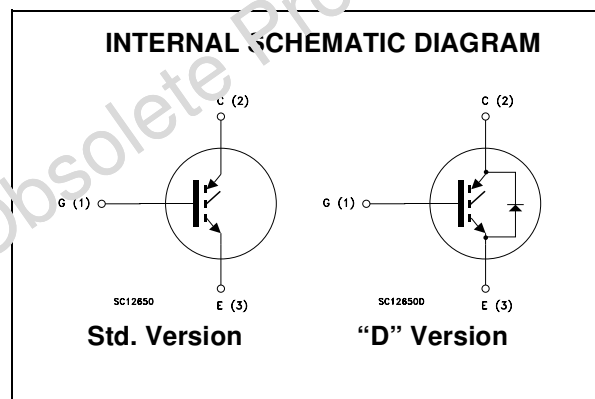

### ORDERING INFORMATION

SALES TYPE	MARKING	PACKAGE	PACKAGING
STGP3NB60F	GP3NB60F	TO-220	TUBE
STGD3NB60FT4	GD3NB60F	DPAK	TAPE & REEL
STGP3NB60FD	GP3NB60FD	TO-220	TUBE
STGF3NB60FD	GF3NB60FD	TO-220FP	TUBE
STGB3NB60FDT4	GB3NB60FD	D <sup>2</sup> PAK	TAPE & REEL

## STGP3NB60F/STGD3NB60F/STGP3NB60FD/STGF3NB60FD/STGB3NB60FD

### ABSOLUTE MAXIMUM RATINGS

Symbol	Parameter	Value			Unit
		TO-220/D <sup>2</sup> PAK	TO-220FP	DPAK	
V <sub>CEs</sub>	Collector-Emitter Voltage (V <sub>GS</sub> = 0)	600			V
V <sub>ECR</sub>	Emitter-Collector Voltage	20			V
V <sub>GE</sub>	Gate-Emitter Voltage	±20			V
I <sub>C</sub>	Collector Current (continuous) at T <sub>C</sub> = 25°C	6			A
I <sub>C</sub>	Collector Current (continuous) at T <sub>C</sub> = 100°C	3			A
I <sub>CM</sub> (■)	Collector Current (pulsed)	24			A
I <sub>f</sub> (1)	Forward Current	3			A
I <sub>fm</sub> (1)	Forward Current Pulsed	24			A
P <sub>TOT</sub>	Total Dissipation at T <sub>C</sub> = 25°C	68	25	60	W
	Derating Factor	0.55	0.2	0.47	W/°C
V <sub>ISO</sub>	Insulation Withstand Voltage A.C.	--	2500	--	V
T <sub>stg</sub>	Storage Temperature	- 55 to 150			°C
T <sub>j</sub>	Max. Operating Junction Temperature	150			°C

(■) Pulse width limited by safe operating area

(1) For "D" version only

### THERMAL DATA

		TO-220/D <sup>2</sup> PAK	TO-220FP	DPAK	
R <sub>thj-case</sub>	Thermal Resistance Junction-case Max	1.8	5	2.1	°C/W
R <sub>thj-amb</sub>	Thermal Resistance Junction-ambient Max	62.5		100	°C/W
R <sub>thc-h</sub>	Thermal Resistance Case-heatsink Typ	0.5			°C/W

### ELECTRICAL CHARACTERISTICS (T<sub>CASE</sub> = 25°C UNLESS OTHERWISE SPECIFIED)

#### MAIN PARAMETERS

Symbol	Parameter	Test Conditions	Min.	Typ.	Max.	Unit
V <sub>BR(CES)</sub>	Collector-Emitter Breakdown Voltage	I <sub>C</sub> = 250 μA, V <sub>GE</sub> = 0	600			V
I <sub>CES</sub>	Collector cut-off (V <sub>GE</sub> = 0)	V <sub>CE</sub> = Max Rating, T <sub>C</sub> = 25°C V <sub>CE</sub> = Max Rating, T <sub>C</sub> = 125°C			50 100	μA μA
I <sub>GES</sub>	Gate-Emitter Leakage Current (V <sub>CE</sub> = 0)	V <sub>GE</sub> = ±20V, V <sub>CE</sub> = 0			±100	nA
V <sub>GE(th)</sub>	Gate Threshold Voltage	V <sub>CE</sub> = V <sub>GE</sub> , I <sub>C</sub> = 250 μA	3		5	V
V <sub>CE(sat)</sub>	Collector-Emitter Saturation Voltage	V <sub>GE</sub> = 15 V, I <sub>C</sub> = 3 A		1.9	2.4	V
		V <sub>GE</sub> = 15 V, I <sub>C</sub> = 3 A, T <sub>j</sub> = 125°C		1.6		V

**STGP3NB60F/STGD3NB60F/STGP3NB60FD/STGF3NB60FD/STGB3NB60FD**

**SWITCHING PARAMETERS**

Symbol	Parameter	Test Conditions	Min.	Typ.	Max.	Unit
$g_{fs}$	Forward Transconductance	$V_{CE} = 25 \text{ V}, I_C = 3 \text{ A}$		2		S
$C_{ies}$ $C_{oes}$ $C_{res}$	Input Capacitance Output Capacitance Reverse Transfer Capacitance	$V_{CE} = 25 \text{ V}, f = 1 \text{ MHz}, V_{GE} = 0$		230 33 6		pF pF pF
$Q_g$ $Q_{ge}$ $Q_{gc}$	Total Gate Charge Gate-Emitter Charge Gate-Collector Charge	$V_{CE} = 480 \text{ V}, I_C = 3 \text{ A},$ $V_{GE} = 15 \text{ V}$		16 1.5 8	20	nC nC nC
$t_{d(on)}$ $t_r$	Turn-on Delay Time Rise Time	$V_{CC} = 480 \text{ V}, I_C = 3 \text{ A}$ $R_G = 10\Omega, V_{GE} = 15 \text{ V}$		12.5 4		ns ns
$(di/dt)_{on}$ $E_{on}$	Turn-on Current Slope Turn-on Switching Losses	$V_{CC} = 480 \text{ V}, I_C = 3 \text{ A}, R_G = 10\Omega$ $V_{GE} = 15 \text{ V}, T_j = 125^\circ\text{C}$		840 31		A/ $\mu\text{s}$ $\mu\text{J}$
$t_c$ $t_r(V_{off})$ $t_{d(off)}$ $t_f$ $E_{off(**)}$ $E_{ts}$	Cross-over Time Off Voltage Rise Time Delay Time Fall Time Turn-off Switching Loss Total Switching Loss	$V_{CC} = 480 \text{ V}, I_C = 3 \text{ A},$ $R_{GE} = 10 \Omega, V_{GE} = 15 \text{ V}$ $T_j = 25^\circ\text{C}$		220 60 105 150 125 149		ns ns ns ns $\mu\text{J}$ $\mu\text{J}$
$t_c$ $t_r(V_{off})$ $t_{d(off)}$ $t_f$ $E_{off(**)}$ $E_{ts}$	Cross-over Time Off Voltage Rise Time Delay Time Fall Time Turn-off Switching Loss Total Switching Loss	$V_{CC} = 480 \text{ V}, I_C = 3 \text{ A},$ $R_{GE} = 10 \Omega, V_{GE} = 15 \text{ V}$ $T_j = 125^\circ\text{C}$		490 174 230 305 295 326		ns ns ns ns $\mu\text{J}$ $\mu\text{J}$

**COLLECTOR-EMITTER DIODE ("D" VERSION)**

Symbol	Parameter	Test Conditions	Min.	Typ.	Max.	Unit
$V_f$	Forward On-Voltage	$I_f = 1.5 \text{ A}$ $I_f = 1.5 \text{ A}, T_j = 125^\circ\text{C}$		1.31 0.95	1.8	V V
$t_{rr}$ $Q_{rr}$ $I_{rrm}$	Reverse Recovery Time Reverse Recovery Charge Reverse Recovery Current	$I_f = 3 \text{ A}, V_R = 35 \text{ V},$ $T_j = 125^\circ\text{C}, di/dt = 100 \text{ A}/\mu\text{s}$		45 70 2.7		ns nC A

Note: 1. Pulsed: Pulse duration = 300  $\mu\text{s}$ , duty cycle 1.5 %.  
 2. Pulse width limited by max. junction temperature.  
 (\*\*)Losses include Also the Tail (Jedec Standardization)

Output Characteristics

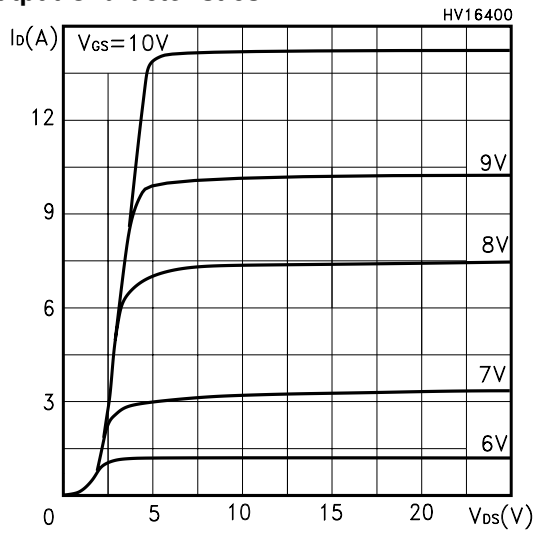

Transfer Characteristics

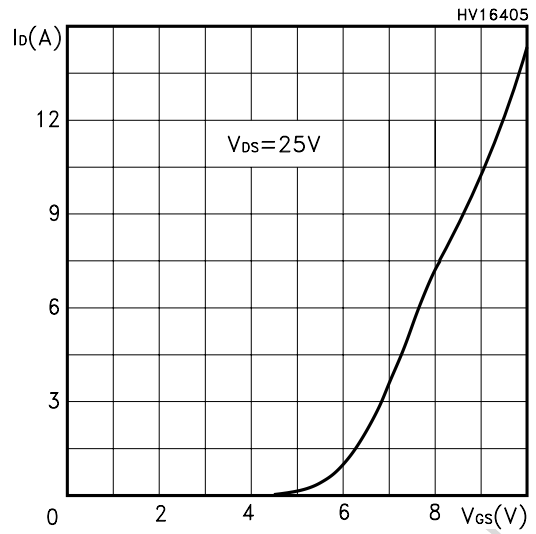

Transconductance

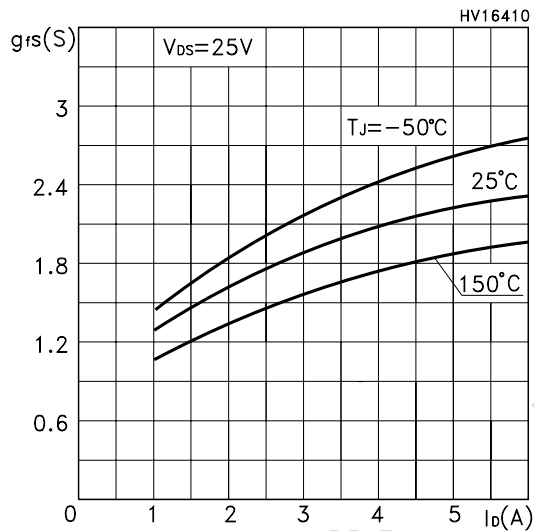

Collector-Emitter On Voltage vs Temperature

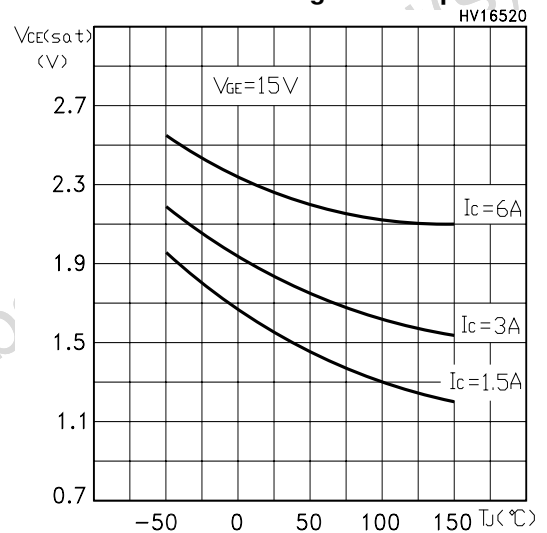

Collector-Emitter On Voltage vs Collector Current

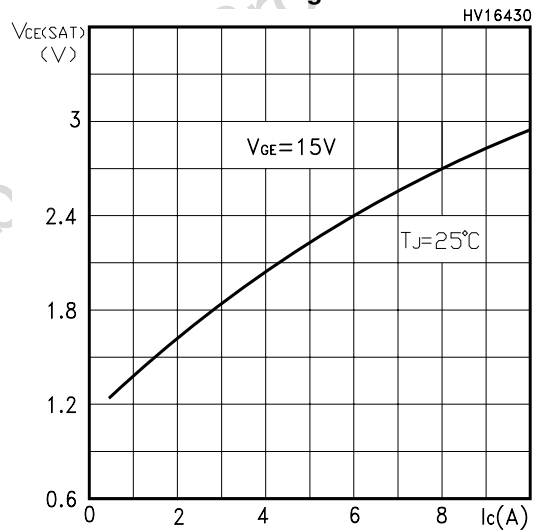

Normalized Collector-Emitter On Voltage vs Temp.

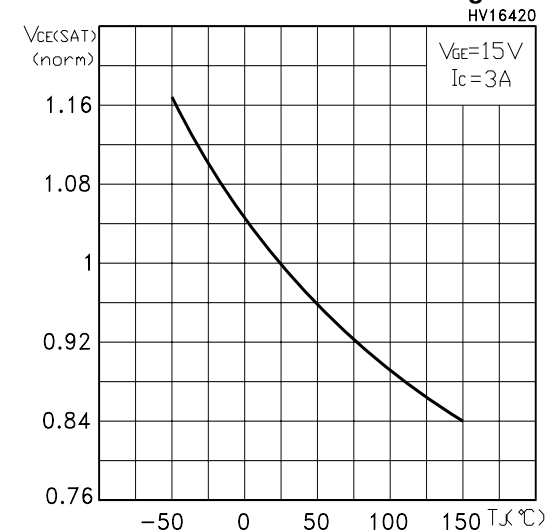

Gate Threshold vs Temperature

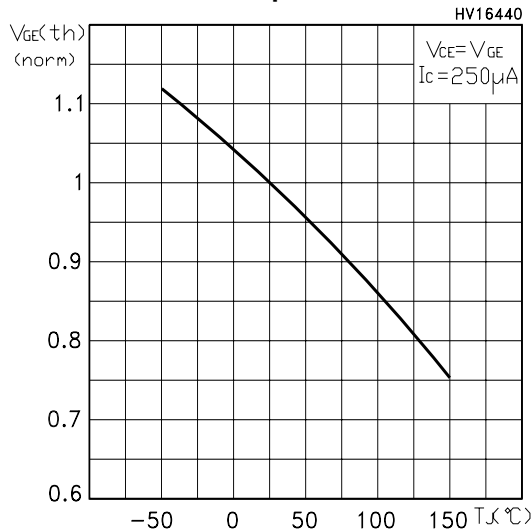

Normalized Breakdown Voltage vs Temperature

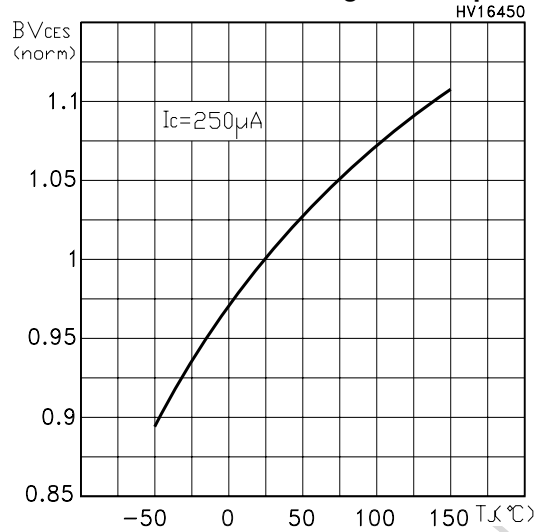

Capacitance Variations

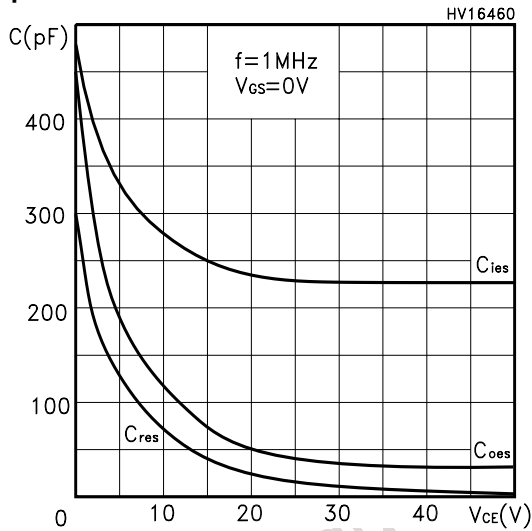

Gate Charge vs Gate-Emitter Voltage

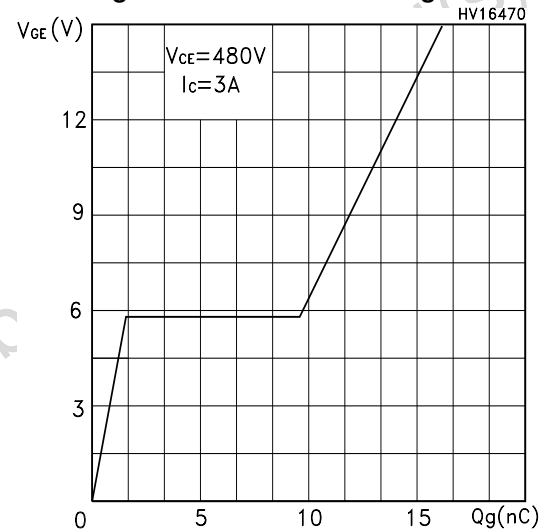

Total Switching Losses vs Gate Resistance

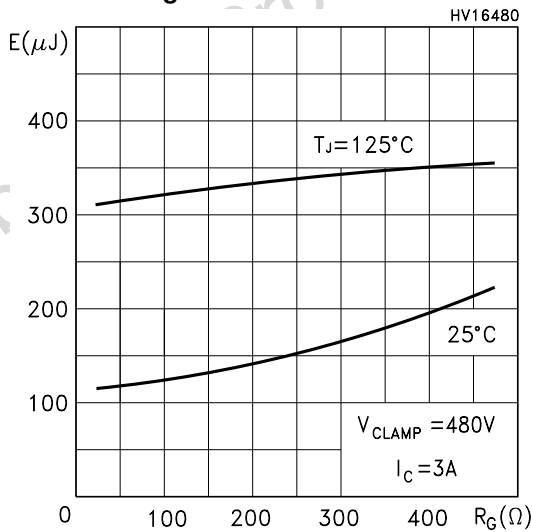

Total Switching Losses vs Temperature

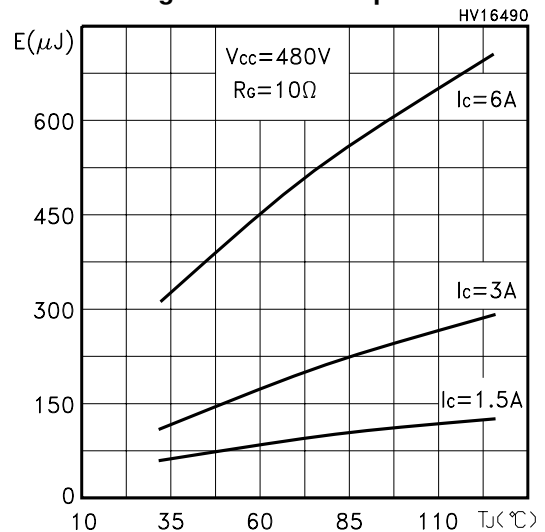

Emitter-collector Diode Characteristics

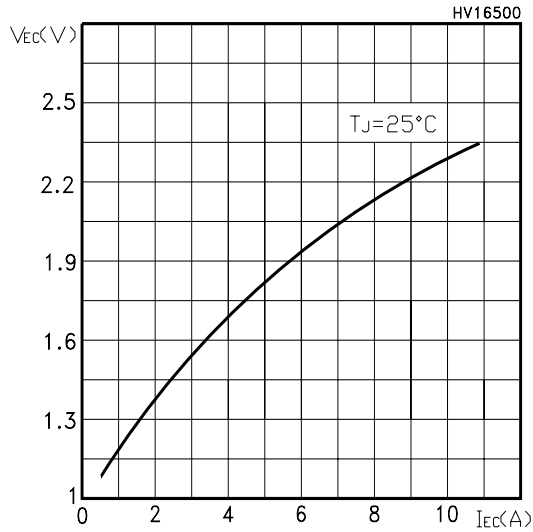

Turn-Off SOA

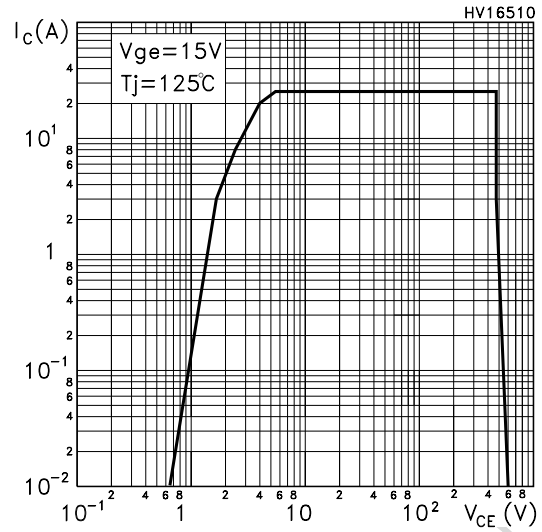

Thermal Impedance for TO-220 / D2PAK

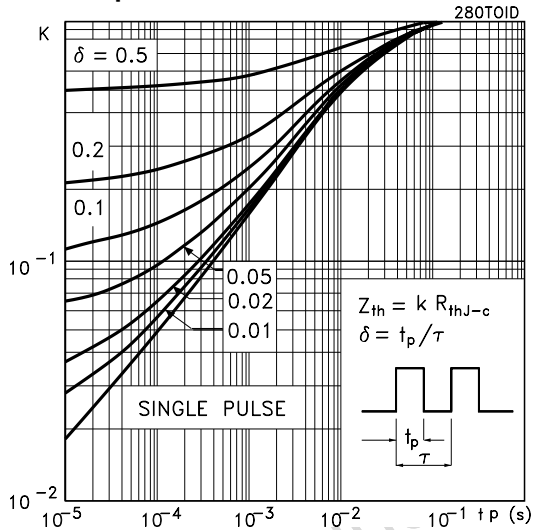

Thermal Impedance for TO-220FP

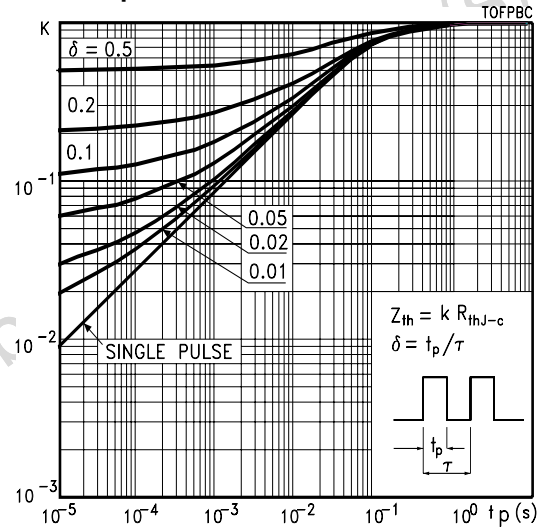

Thermal Impedance for DPAK

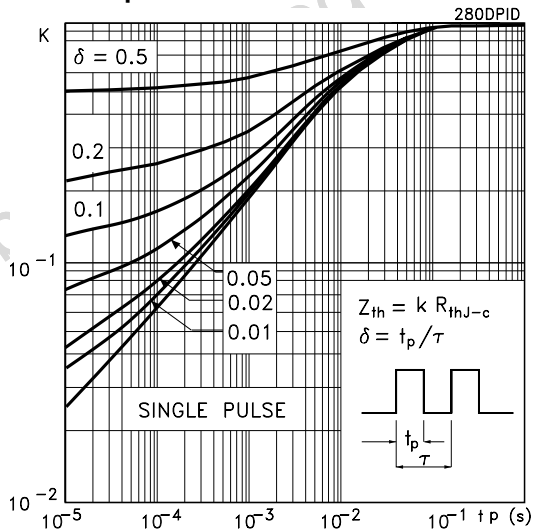





**TO-220 MECHANICAL DATA**

DIM.	mm.			inch		
	MIN.	TYP.	MAX.	MIN.	TYP.	MAX.
A	4.40		4.60	0.173		0.181
b	0.61		0.88	0.024		0.034
b1	1.15		1.70	0.045		0.066
c	0.49		0.70	0.019		0.027
D	15.25		15.75	0.60		0.620
E	10		10.40	0.393		0.409
e	2.40		2.70	0.094		0.106
e1	4.95		5.15	0.194		0.202
F	1.23		1.32	0.048		0.052
H1	6.20		6.60	0.244		0.256
J1	2.40		2.72	0.094		0.107
L	13		14	0.511		0.551
L1	3.50		3.93	0.137		0.154
L20		16.40			0.645	
L30		28.90			1.137	
øP	3.75		3.85	0.147		0.151
Q	2.65		2.95	0.104		0.116

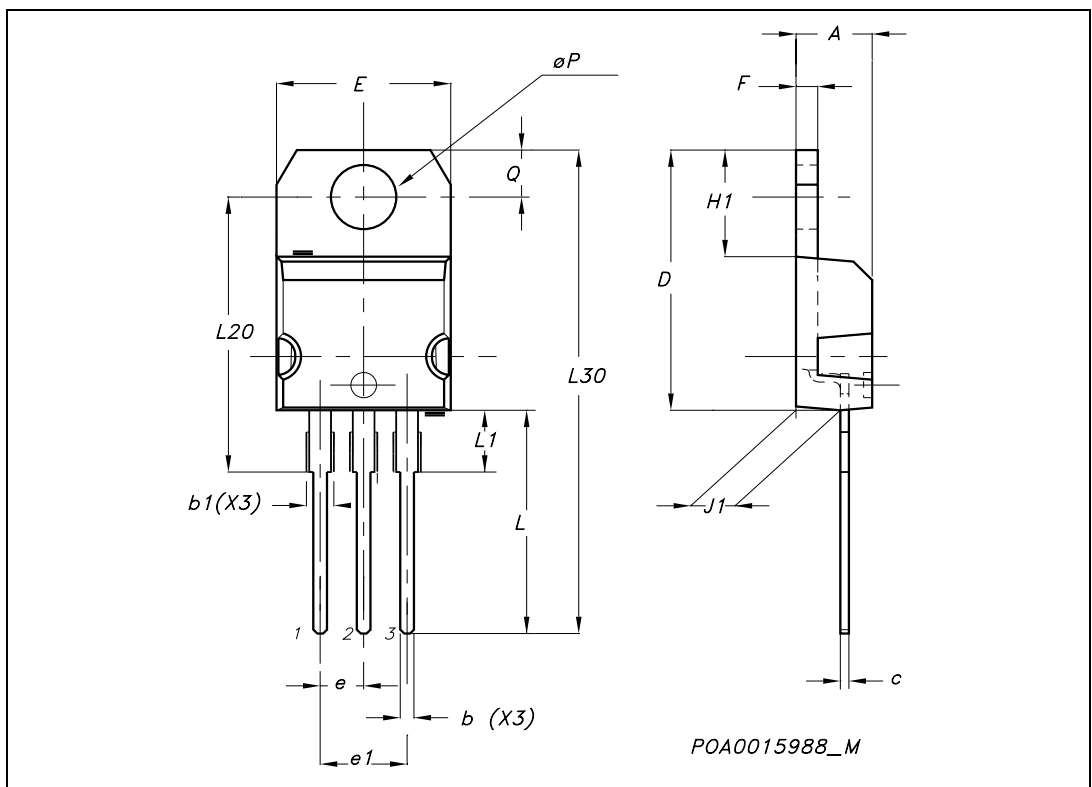

TO-220FP MECHANICAL DATA

DIM.	mm			inch		
	MIN.	TYP.	MAX.	MIN.	TYP.	MAX.
A	4.4		4.6	0.173		0.181
B	2.5		2.7	0.098		0.106
D	2.5		2.75	0.098		0.108
E	0.45		0.7	0.017		0.027
F	0.75		1	0.030		0.039
F1	1.15		1.7	0.045		0.067
F2	1.15		1.7	0.045		0.067
G	4.95		5.2	0.195		0.204
G1	2.4		2.7	0.094		0.106
H	10		10.4	0.393		0.409
L2		16			0.630	
L3	28.6		30.6	1.126		1.204
L4	9.8		10.6	0.385		0.417
L6	15.9		16.4	0.626		0.645
L7	9		9.3	0.354		0.366
Ø	3		3.2	0.118		0.126

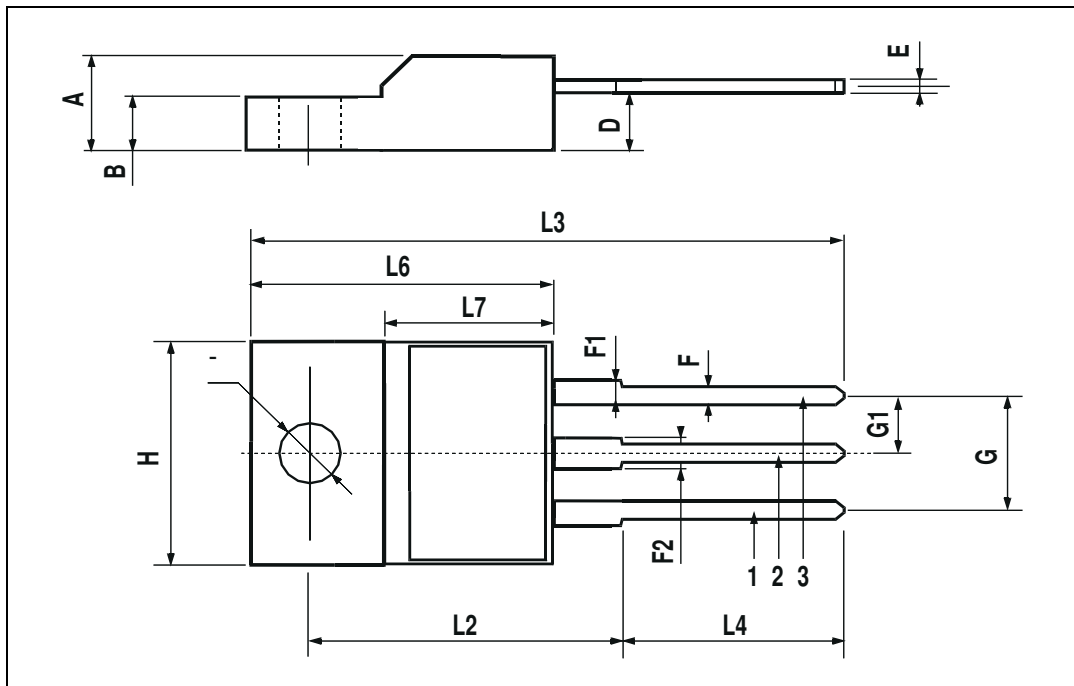

TO-252 (DPAK) MECHANICAL DATA

DIM.	mm			inch		
	MIN.	TYP.	MAX.	MIN.	TYP.	MAX.
A	2.20		2.40	0.087		0.094
A1	0.90		1.10	0.035		0.043
A2	0.03		0.23	0.001		0.009
B	0.64		0.90	0.025		0.035
B2	5.20		5.40	0.204		0.213
C	0.45		0.60	0.018		0.024
C2	0.48		0.60	0.019		0.024
D	6.00		6.20	0.236		0.244
E	6.40		6.60	0.252		0.260
G	4.40		4.60	0.173		0.181
H	9.35		10.10	0.368		0.398
L2		0.8			0.031	
L4	0.60		1.00	0.024		0.039
V2	0°		8°	0°		0°

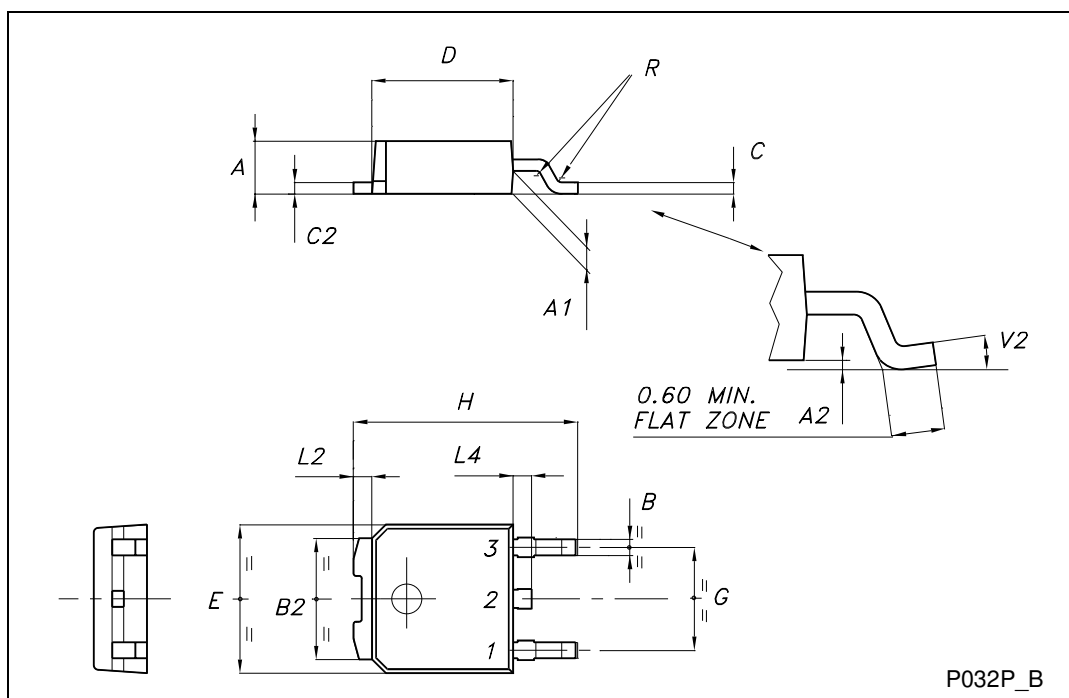

**D<sup>2</sup>PAK MECHANICAL DATA**

DIM.	mm.			inch		
	MIN.	TYP	MAX.	MIN.	TYP.	MAX.
A	4.4		4.6	0.173		0.181
A1	2.49		2.69	0.098		0.106
A2	0.03		0.23	0.001		0.009
B	0.7		0.93	0.027		0.036
B2	1.14		1.7	0.044		0.067
C	0.45		0.6	0.017		0.023
C2	1.23		1.36	0.048		0.053
D	8.95		9.35	0.352		0.368
D1		8			0.315	
E	10		10.4	0.393		
E1		8.5			0.334	
G	4.88		5.28	0.192		0.208
L	15		15.85	0.590		0.625
L2	1.27		1.4	0.050		0.055
L3	1.4		1.75	0.055		0.068
M	2.4		3.2	0.094		0.126
R		0.4			0.015	
V2	0°		8°			

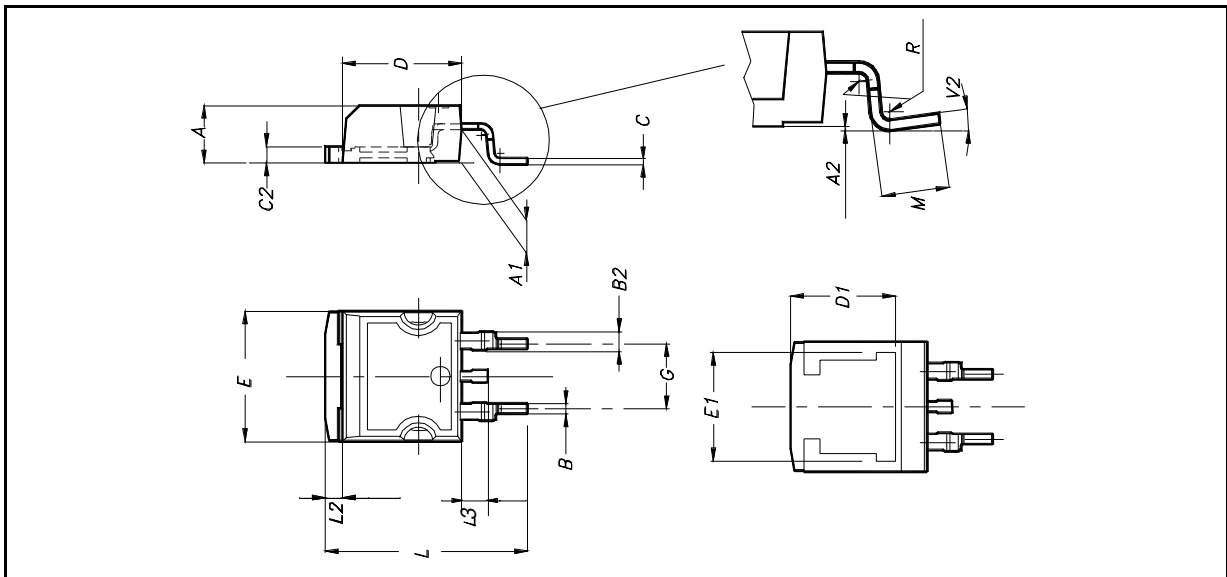

**DPAK FOOTPRINT**

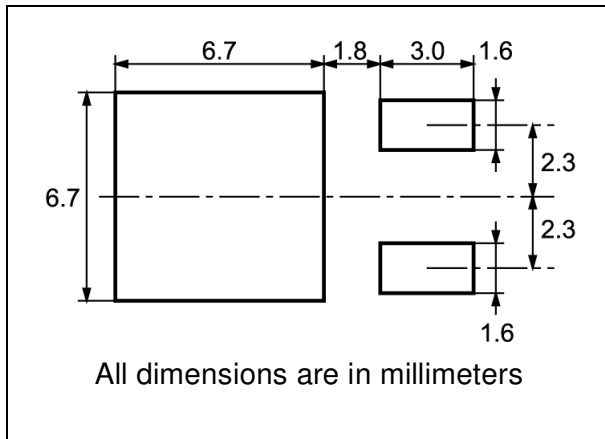

**TUBE SHIPMENT (no suffix)\***

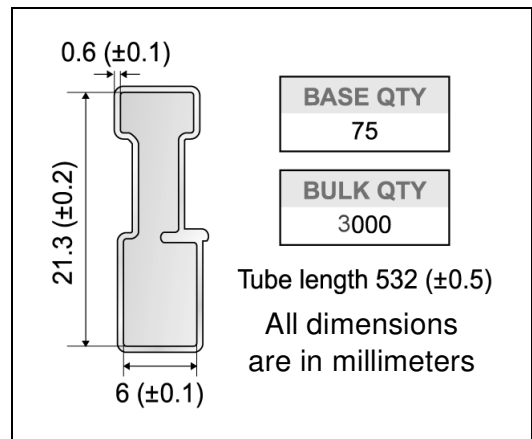

**TAPE AND REEL SHIPMENT (suffix "T4")\***

**REEL MECHANICAL DATA**

DIM.	mm		inch	
	MIN.	MAX.	MIN.	MAX.
A		330		12.992
B	1.5		0.059	
C	12.8	13.2	0.504	0.520
D	20.2		0.795	
G	16.4	18.4	0.645	0.724
N	50		1.968	
T		22.4		0.881

BASE QTY	BULK QTY
2500	2500

**TAPE MECHANICAL DATA**

DIM.	mm		inch	
	MIN.	MAX.	MIN.	MAX.
A0	6.8	7	0.267	0.275
B0	10.4	10.6	0.409	0.417
B1		12.1		0.476
D	1.5	1.6	0.059	0.063
D1	1.5		0.059	
E	1.65	1.85	0.065	0.073
F	7.4	7.6	0.291	0.299
K0	2.55	2.75	0.100	0.108
P0	3.9	4.1	0.153	0.161
P1	7.9	8.1	0.311	0.319
P2	1.9	2.1	0.075	0.082
R	40		1.574	
W	15.7	16.3	0.618	0.641

\* on sales type



**D<sup>2</sup>PAK FOOTPRINT**

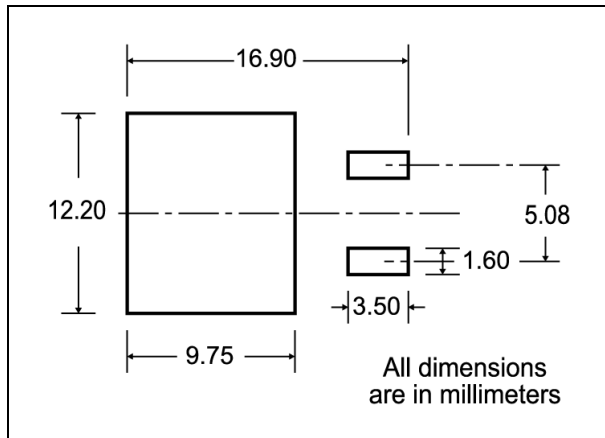

**TUBE SHIPMENT (no suffix)\***

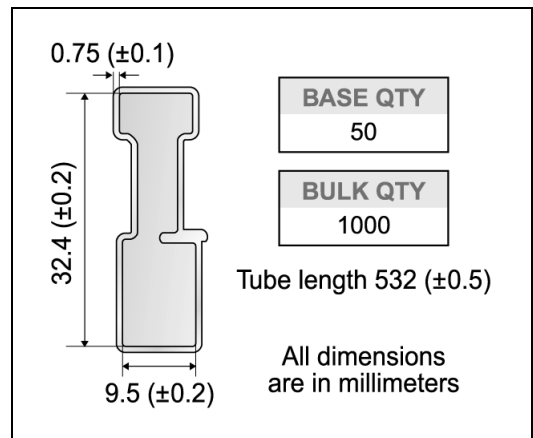

**TAPE AND REEL SHIPMENT (suffix "T4")\***

Diagram showing the tape mechanical data. Dimensions include A (total width), B (slot width), C (slot depth), D (slot depth), D1 (slot depth), E (slot depth), F (slot depth), G (measured at hub), K0 (top cover tape thickness), P0 (pitch), P1 (pitch), P2 (pitch), R (radius), T (thickness), and W (width). A 40 mm min. access hole is required at the slot location. The tape slot in the core for tape start has a 2.5 mm min. width. The full radius is also indicated.

**REEL MECHANICAL DATA**

DIM.	mm		inch	
	MIN.	MAX.	MIN.	MAX.
A		330		12.992
B	1.5		0.059	
C	12.8	13.2	0.504	0.520
D	20.2		0.795	
G	24.4	26.4	0.960	1.039
N	100		3.937	
T		30.4		1.197

BASE QTY	BULK QTY
1000	1000

**TAPE MECHANICAL DATA**

DIM.	mm		inch	
	MIN.	MAX.	MIN.	MAX.
A0	10.5	10.7	0.413	0.421
B0	15.7	15.9	0.618	0.626
D	1.5	1.6	0.059	0.063
D1	1.59	1.61	0.062	0.063
E	1.65	1.85	0.065	0.073
F	11.4	11.6	0.449	0.456
K0	4.8	5.0	0.189	0.197
P0	3.9	4.1	0.153	0.161
P1	11.9	12.1	0.468	0.476
P2	1.9	2.1	0.075	0.082
R	50		1.574	
T	0.25	0.35	0.0098	0.0137
W	23.7	24.3	0.933	0.956

Diagrams showing the tape and reel shipment. The top diagram shows the tape with dimensions K0, D, P0, P1, P2, E, F, W, B0, D1, A0, and P1. The bottom diagram shows the reel with dimensions TRL, FEED DIRECTION, and Bending radius (R min.).

\* on sales



Information furnished is believed to be accurate and reliable. However, STMicroelectronics assumes no responsibility for the consequences of use of such information nor for any infringement of patents or other rights of third parties which may result from its use. No license is granted by implication or otherwise under any patent or patent rights of STMicroelectronics. Specifications mentioned in this publication are subject to change without notice. This publication supersedes and replaces all information previously supplied. STMicroelectronics products are not authorized for use as critical components in life support devices or systems without express written approval of STMicroelectronics.

© The ST logo is a registered trademark of STMicroelectronics

© 2003 STMicroelectronics - Printed in Italy - All Rights Reserved  
STMicroelectronics GROUP OF COMPANIES

Australia - Brazil - Canada - China - Finland - France - Germany - Hong Kong - India - Israel - Italy - Japan - Malaysia - Malta - Morocco  
Singapore - Spain - Sweden - Switzerland - United Kingdom - United States.

© <http://www.st.com>