



Chipsmall Limited consists of a professional team with an average of over 10 year of expertise in the distribution of electronic components. Based in Hongkong, we have already established firm and mutual-benefit business relationships with customers from,Europe,America and south Asia,supplying obsolete and hard-to-find components to meet their specific needs.

With the principle of “Quality Parts,Customers Priority,Honest Operation,and Considerate Service”,our business mainly focus on the distribution of electronic components. Line cards we deal with include Microchip,ALPS,ROHM,Xilinx,Pulse,ON,Everlight and Freescale. Main products comprise IC,Modules,Potentiometer,IC Socket,Relay,Connector.Our parts cover such applications as commercial,industrial, and automotives areas.

We are looking forward to setting up business relationship with you and hope to provide you with the best service and solution. Let us make a better world for our industry!



Contact us

Tel: +86-755-8981 8866 Fax: +86-755-8427 6832

Email & Skype: info@chipsmall.com Web: www.chipsmall.com

Address: A1208, Overseas Decoration Building, #122 Zhenhua RD., Futian, Shenzhen, China



SLLIMM™ - 2nd series IPM, 3-phase inverter, 10 A, 600 V short-circuit rugged IGBTs

Datasheet - production data

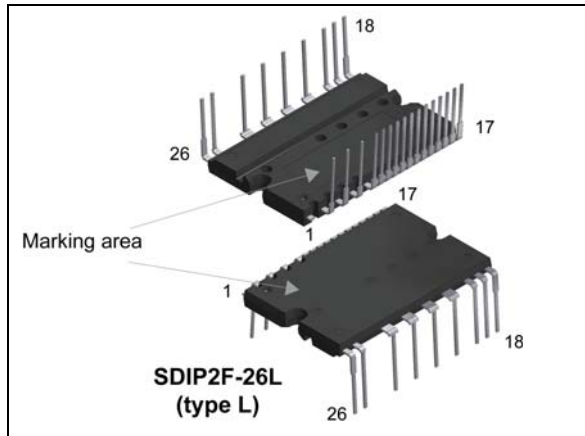

Features

- IPM 10 A, 600 V 3-phase IGBT inverter bridge including 2 control ICs for gate driving and freewheeling diodes
- 3.3 V, 5 V TTL/CMOS inputs with hysteresis
- Internal bootstrap diode
- Undervoltage lockout of gate drivers
- Smart shutdown function
- Short-circuit protection
- Shutdown input/fault output
- Separate open emitter outputs
- Built-in temperature sensor
- Comparator for fault protection
- Short-circuit rugged TFS IGBTs
- Very fast, soft recovery diodes
- 85 kΩ NTC UL 1434 CA 4 recognized
- Fully isolated package
- Isolation rating of 1500 Vrms/min

Applications

- 3-phase inverters for motor drives
- Home appliances such as washing machines, refrigerators, air conditioners and sewing machines

Description

This second series of SLLIMM (small low-loss intelligent molded module) provides a compact, high performance AC motor drive in a simple, rugged design. It combines new ST proprietary control ICs (one LS and one HS driver) with an improved short-circuit rugged trench gate field-stop (TFS) IGBT, making it ideal for 3-phase inverter systems such as home appliances and air conditioners. SLLIMM™ is a trademark of STMicroelectronics.

Table 1. Device summary

Order code	Marking	Package	Packing
STGIF7CH60TS-L	GIF7CH60TS-L	SDIP2F-26L	Tube

Contents

1	Internal schematic and pin description	3
2	Absolute maximum ratings	5
3	Electrical characteristics	7
4	Fault management	11
	4.1 TSO output	12
	4.2 Smart shutdown function	12
5	Typical application circuit	15
6	Recommendations	16
7	NTC thermistor	18
8	Electrical characteristics (curves)	20
9	Package information	22
10	Revision history	24

1 Internal schematic and pin description

Figure 1. Internal schematic diagram and pin configuration

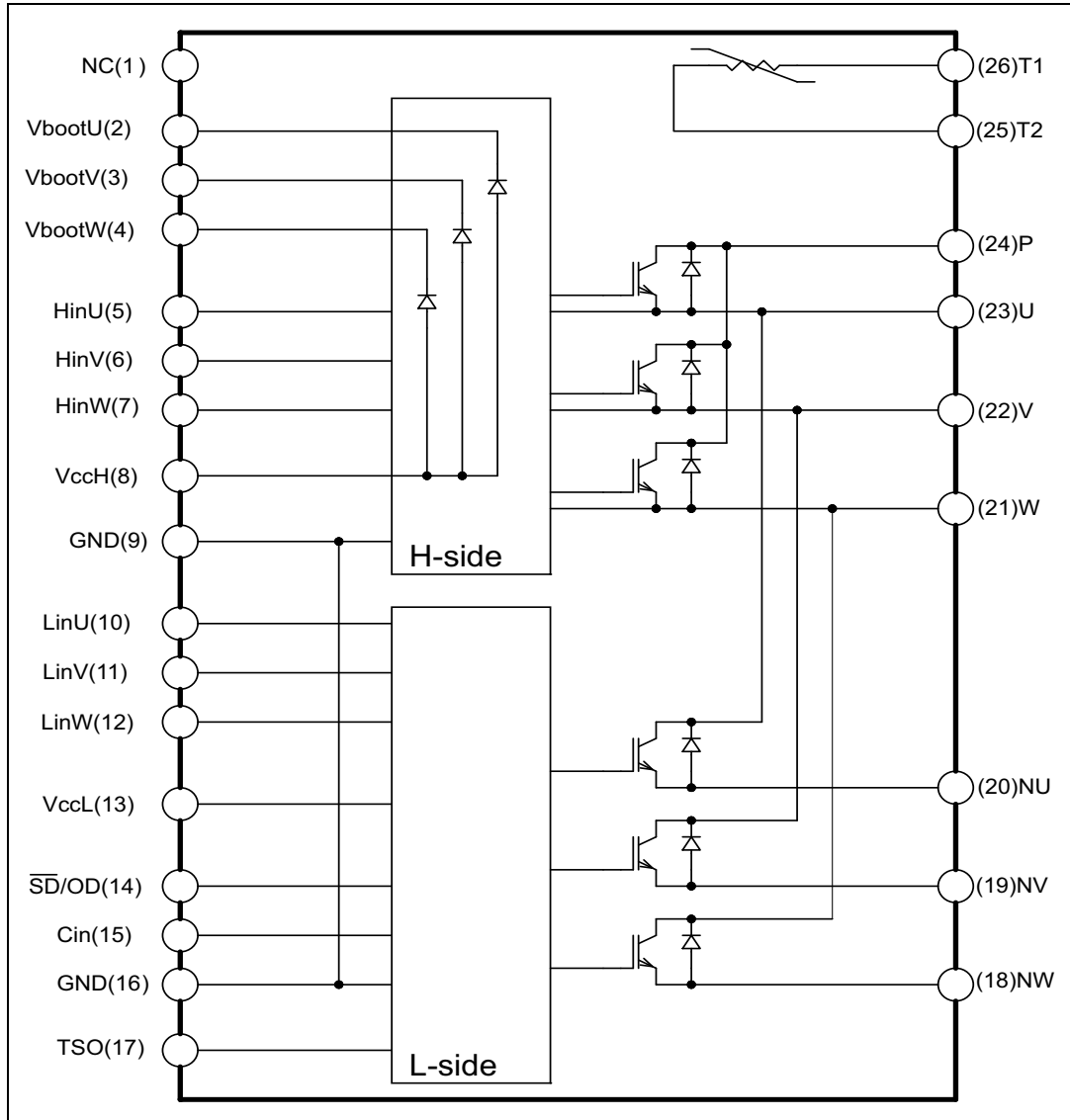

Table 2. Pin description

Pin	Symbol	Description
1	NC	-
2	VBOOTu	Bootstrap voltage for U phase
3	VBOOTv	Bootstrap voltage for V phase
4	VBOOTw	Bootstrap voltage for W phase
5	HINu	High-side logic input for U phase
6	HINv	High-side logic input for V phase
7	HINw	High-side logic input for W phase
8	VCCH	High-side low voltage power supply
9	GND	Ground
10	LINu	Low-side logic input for U phase
11	LINv	Low-side logic input for V phase
12	LINw	Low-side logic input for W phase
13	VCCL	Low-side low voltage power supply
14	$\overline{\text{SD}}/\text{OD}$	Shutdown logic input (active low) / open-drain (comparator output)
15	CIN	Comparator input
16	GND	Ground
17	TSO	Temperature sensor output
18	NW	Negative DC input for W phase
19	NV	Negative DC input for V phase
20	NU	Negative DC input for U phase
21	W	W phase output
22	V	V phase output
23	U	U phase output
24	P	Positive DC input
25	T2	NTC thermistor terminal 2
26	T1	NTC thermistor terminal 1

2 Absolute maximum ratings

($T_J = 25^\circ\text{C}$ unless otherwise noted).

Table 3. Inverter parts

Symbol	Parameter	Value	Unit
V_{PN}	Supply voltage between P -N _U , -N _V , -N _W	450	V
$V_{PN(\text{surge})}$	Supply voltage surge between P -N _U , -N _V , -N _W	500	V
V_{CES}	Collector-emitter voltage each IGBT	600	V
$\pm I_C$	Continuous collector current each IGBT ($T_C = 25^\circ\text{C}$)	10	A
	Continuous collector current each IGBT ($T_C = 80^\circ\text{C}$)	7	
$\pm I_{CP}$	Peak collector current each IGBT (less than 1 ms)	20	A
P_{TOT}	Total dissipation at $T_C = 25^\circ\text{C}$ each IGBT	31	W
t_{SCW}	Short-circuit withstand time, $V_{CE} = 300\text{ V}$, $T_J = 125^\circ\text{C}$, $V_{CC} = V_{boot} = 15\text{ V}$, $V_{IN} = 0\text{ to }5\text{ V}$	5	μs

Table 4. Control parts

Symbol	Parameter	Min	Max	Unit
V_{CC}	Supply voltage between $V_{CCH}\text{-GND}$, $V_{CCL}\text{-GND}$	-0.3	20	V
V_{BOOT}	Bootstrap voltage	-0.3	619	V
V_{OUT}	Output voltage between U, V, W and GND	$V_{BOOT} - 21$	$V_{BOOT} + 0.3$	V
V_{CIN}	Comparator input voltage	-0.3	20	V
V_{IN}	Logic input voltage applied between HINx, LINx and GND	-0.3	15	V
$V_{SD/OD}$	Open drain voltage	-0.3	7	V
$I_{SD/OD}$	Open drain sink current	-	10	mA
V_{TSO}	Temperature sensor output voltage	-0.3	5.5	V
I_{TSO}	Temperature sensor output current	-	7	mA

Table 5. Total system

Symbol	Parameter	Value	Unit
V_{ISO}	Isolation withstand voltage applied between each pin and heat sink plate (AC voltage, $t = 60\text{sec.}$)	1500	Vrms
T_J	Power chips operating junction temperature	-40 to 175	$^\circ\text{C}$
T_C	Module case operation temperature	-40 to 125	$^\circ\text{C}$

Table 6. Thermal data

Symbol	Parameter	Value	Unit
$R_{th(j-c)}$	Thermal resistance junction-case single IGBT	4.8	°C/W
	Thermal resistance junction-case single diode	6	

3 Electrical characteristics

(T_j= 25°C unless otherwise noted).

Table 7. Inverter parts

Symbol	Parameter	Test condition	Min	Typ	Max	Unit
I _{CES}	Collector-cut off current	V _{CE} = 600 V, V _{CC} = V _{boot} = 15 V	-		100	μA
V _{CE(sat)}	Collector-emitter saturation voltage	V _{CC} = V _{Boot} = 15 V, V _{IN} ⁽¹⁾ = 0 to 5 V, I _C = 7 A,	-	1.5	1.95	V
		V _{CC} = V _{Boot} = 15 V, V _{IN} ⁽¹⁾ = 0 to 5 V, I _C = 10 A,	-	1.7		
V _F	Diode forward voltage	V _{IN} ⁽¹⁾ = 0, I _C = 7 A	-	1.5	2.1	V
		V _{IN} ⁽¹⁾ = 0, I _C = 10 A	-	1.6		V
Inductive load switching time and energy ⁽²⁾						
t _{on}	Turn-on time	V _{DD} = 300 V, V _{CC} = V _{boot} = 15 V, V _{IN} ⁽¹⁾ = 0 to 5 V, I _C = 7 A	-	310		ns
t _{c(on)}	Cross-over time on		-	156		
t _{off}	Turn-off time		-	412		
t _{c(off)}	Cross-over time off		-	110		
t _{rr}	Reverse recovery time		-	230		
E _{on}	Turn-on switching loss	V _{DD} = 300 V, V _{CC} = V _{boot} = 15 V, V _{IN} ⁽¹⁾ = 0 to 5 V, I _C = 7 A	-	197		μJ
E _{off}	Turn-off switching loss		-	84		
E _{rr}	Reverse recovery energy loss			21		
t _{on}	Turn-on time	V _{DD} = 300 V, V _{CC} = V _{boot} = 15 V, V _{IN} ⁽¹⁾ = 0 to 5 V, I _C = 10 A	-	320		ns
t _{c(on)}	Cross-over time on		-	172		
t _{off}	Turn-off time		-	400		
t _{c(off)}	Cross-over time off		-	102		
t _{rr}	Reverse recovery time		-	248		
E _{on}	Turn-on switching loss	V _{DD} = 300 V, V _{CC} = V _{boot} = 15 V, V _{IN} ⁽¹⁾ = 0 to 5 V, I _C = 10 A	-	305		μJ
E _{off}	Turn-off switching loss		-	120		
E _{rr}	Reverse recovery energy loss			26		

1. Applied between HIN_x, LIN_x and GND for x = U, V, W
2. t_{on} and t_{off} include the propagation delay time of the internal drive. t_{c(on)} and t_{c(off)} are the switching time of IGBT itself under the internally given gate driving condition.

Figure 2. Switching time test circuit

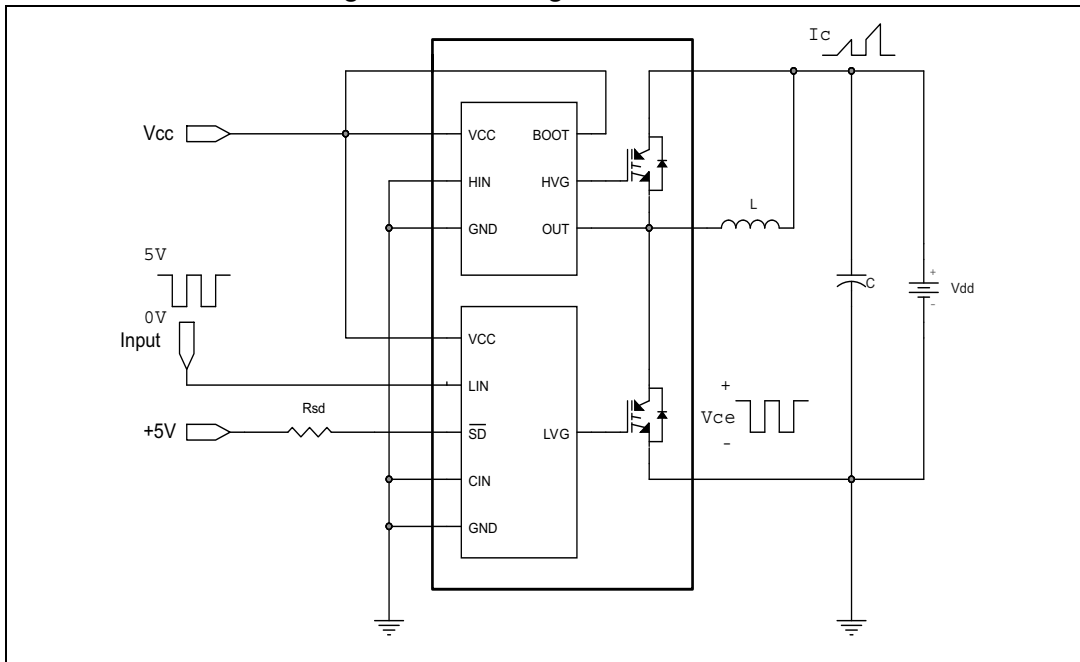

Figure 3. Switching time definition

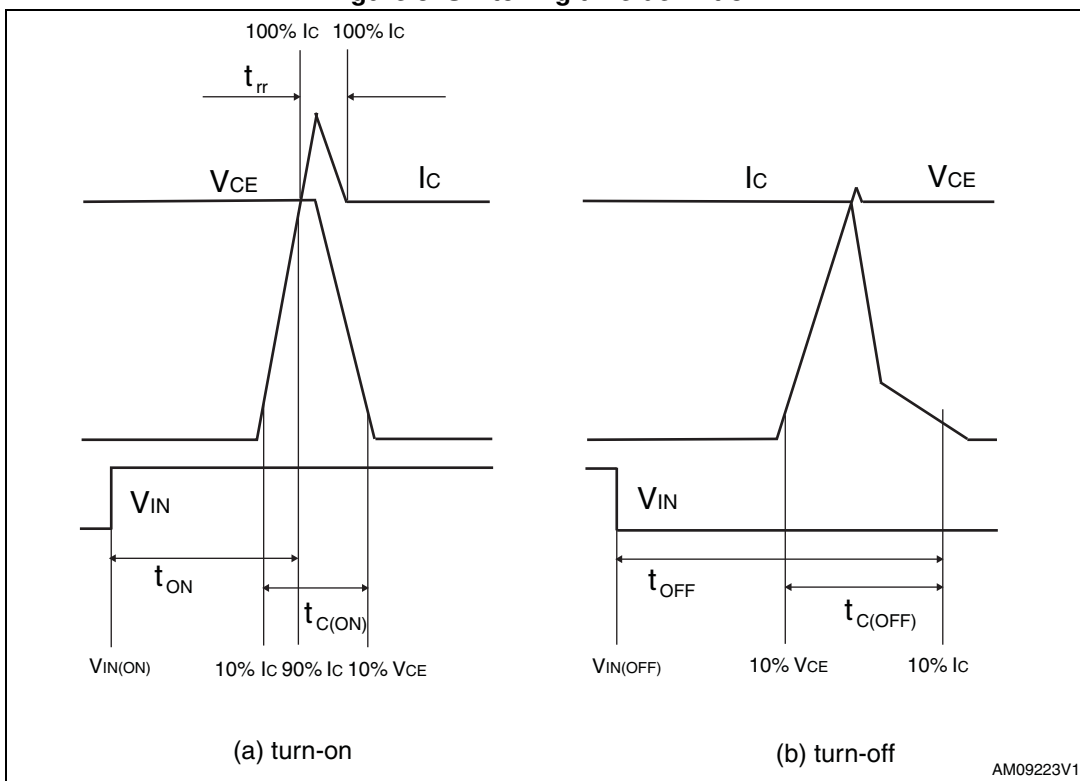

Table 8. Control / protection parts

Symbol	Parameter	Test condition	Min	Typ	Max	Unit
V_{il}	Low logic level voltage				0.8	V
V_{ih}	High logic level voltage		2			V
I_{INh}	IN logic "1" input bias current	$IN_x=15V$	80	150	200	μA
I_{INl}	IN logic "0" input bias current	$IN_x=0V$			1	μA
High side						
V_{CC_hys}	V_{CC} UV hysteresis		1.2	1.4	1.7	V
$V_{CCH_th(on)}$	V_{CCH} UV turn-on threshold		11	11.5	12	V
$V_{CCH_th(off)}$	V_{CCH} UV turn-off threshold		9.6	10.1	10.6	V
V_{BS_hys}	V_{BS} UV hysteresis		0.5	1	1.6	V
$V_{BS_th(on)}$	V_{BS} UV turn-on threshold		10.1	11	11.9	V
$V_{BS_th(off)}$	V_{BS} UV turn-off threshold		9.1	10	10.9	V
I_{QBSU}	Under voltage V_{BS} quiescent current	$V_{BS} = 9 V, HIN_x^{(1)} = 5V;$		55	75	μA
I_{QBS}	V_{BS} quiescent current	$V_{CC} = 15 V,$ $HIN_x^{(1)} = 5V$		125	170	μA
I_{qccu}	Under voltage quiescent supply current	$V_{CC} = 9 V, HIN_x^{(1)} = 0$		190	250	μA
I_{qcc}	Quiescent current	$V_{CC} = 15 V, HIN_x^{(1)} = 0$		560	730	μA
$R_{DS(on)}$	BS driver ON resistance			150		Ω
Low side						
V_{CC_hys}	V_{CC} UV hysteresis		1.1	1.4	1.6	V
$V_{CCL_th(on)}$	V_{CCL} UV turn-on threshold		10.4	11.6	12.4	V
$V_{CCL_th(off)}$	V_{CCL} UV turn-off threshold		9.0	10.3	11	V
I_{qccu}	Under voltage quiescent supply current	$V_{CC} = 10 V, \overline{SD}$ pulled to 5V through $R_{SD} = 10k\Omega,$ $CIN = LIN_x^{(1)} = 0;$		600	800	μA
I_{qcc}	Quiescent current	$V_{CC} = 15 V, \overline{SD} = 5V,$ $CIN = LIN_x^{(1)} = 0;$		700	900	μA
V_{SSD}	Smart \overline{SD} unlatch threshold		0.5	0.6	0.75	V
I_{SDh}	\overline{SD} logic "1" input bias current	$\overline{SD} = 5V$	25	50	70	μA
I_{SDl}	\overline{SD} logic "0" input bias current	$\overline{SD} = 0V$			1	μA

Table 8. Control / protection parts (continued)

Symbol	Parameter	Test condition	Min	Typ	Max	Unit
Temperature sensor output						
V_{TSO}	Temperature sensor output voltage	$T_j = 25\text{ }^\circ\text{C}$		1.4		V
I_{TSO_SNK}	Temperature sensor sink current capability			0.1		mA
I_{TSO_SRC}	Temperature sensor source current capability		4			mA

1. Applied between HINx, LINx and GND for x = U, V, W

Table 9. Sense comparator ($V_{CC} = 15\text{ V}$, unless otherwise is specified)

Symbol	Parameter	Test condition	Min	Typ	Max	Unit
I_{CIN}	CIN input bias current	$V_{CIN} = 1\text{ V}$	-0.2		0.2	μA
V_{ref}	Internal reference voltage		460	510	560	mV
V_{OD}	Open drain low level output voltage	$I_{od} = 5\text{ mA}$			500	mV
t_{CIN_SD}	C_{IN} comparator delay to \overline{SD}	\overline{SD} pulled to 5V through $R_{SD}=10\text{ k}\Omega$; measured applying a voltage step 0-1V to Pin CIN 50% CIN to 90% \overline{SD}	150	230	320	ns
SR_{SD}	\overline{SD} fall slew rate	\overline{SD} pulled to 5V through $R_{SD}=10\text{ k}\Omega$; $C_L=1\text{ nF}$ through \overline{SD} and ground; 90% \overline{SD} to 10% \overline{SD}		25		V/ μs

Note: Comparator remains enabled even if V_{CC} is in the UVLO condition but higher than 4 V.

4 Fault management

The device integrates an open-drain output connected to \overline{SD} Pin. As soon as a fault occurs the open-drain is activated and LVGx outputs are forced low. Two types of fault can be detected:

- Overcurrent (OC) sensed by the internal comparator (see more detail in [Section 4.2: Smart shutdown function](#));
- Undervoltage on supply voltage (V_{CC});

Each fault enables the SD open drain for a different time; refer to the following [Table 10: Fault timing](#).

Table 10. Fault timing

Symbol	Parameter	Event time	SD open-drain enable time result
OC	Over-current event	$\leq 20 \mu s$	20 μs
		$\geq 20 \mu s$	OC time
UVLO	Under-voltage lock out event	$\leq 50 \mu s$	50 μs
		$\geq 50 \mu s$ until the V_{CC_LS} exceed the V_{CC_LS} UV turn ON threshold	UVLO time

The device actually device remains in a fault condition (\overline{SD} at low logic level and LVGx outputs disabled) for a time also depending on RC network connected to \overline{SD} pin. The network generates a time contribution that is added to the internal value.

Figure 4. Overcurrent timing (without contribution of RC network on \overline{SD})

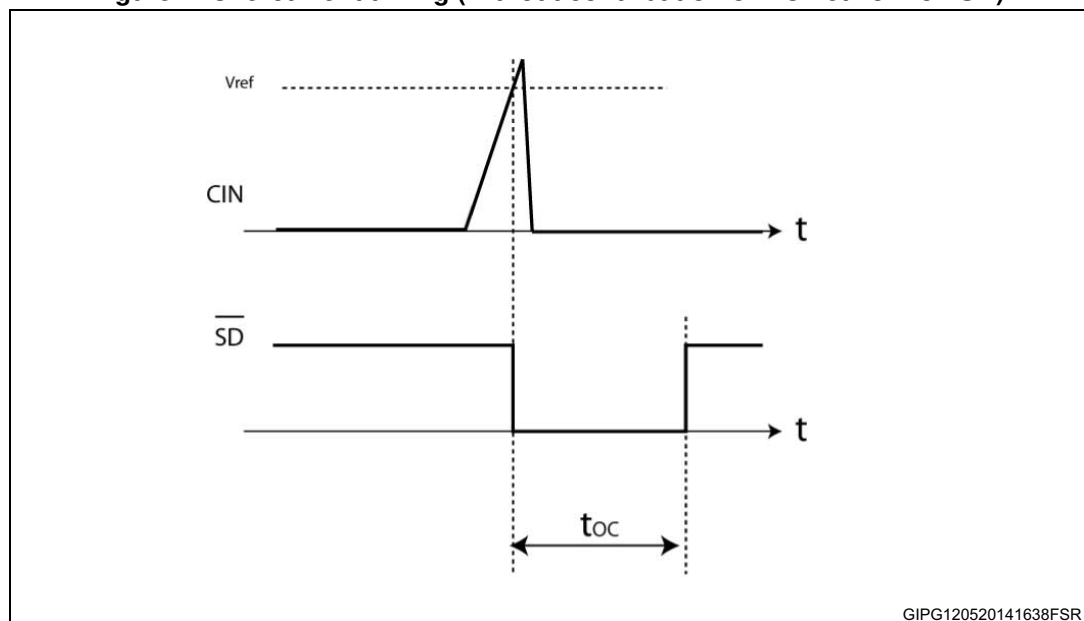

GIPG120520141638FSR

Figure 5. UVLO timing (without contribution of RC network on \overline{SD})

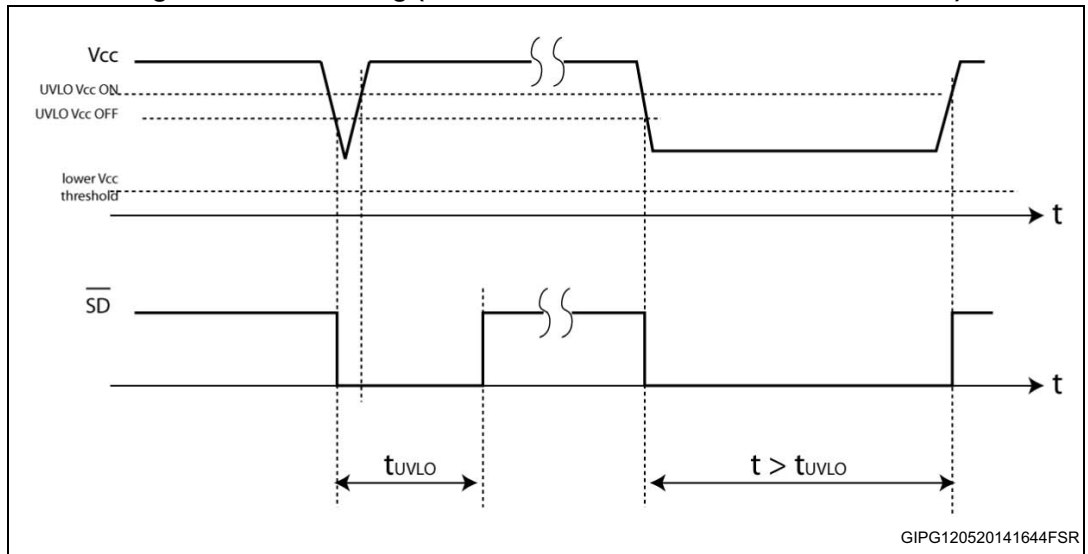

GIPG120520141644FSR

4.1 TSO output

The device integrates temperature sensor. A voltage proportional to die temperature is available on TSO pin. When this function is not used the Pin can be left floating.

4.2 Smart shutdown function

The device integrates a comparator committed to the fault sensing function. The comparator input can be connected to an external shunt resistor in order to implement a simple overcurrent detection function.

The output signal of the comparator is fed to an integrated MOSFET with the open drain output available on \overline{SD} input. When the comparator triggers, the device is set to the shutdown state and its outputs are all set to low.

Figure 6. Smart shutdown timing waveforms in case of overcurrent event

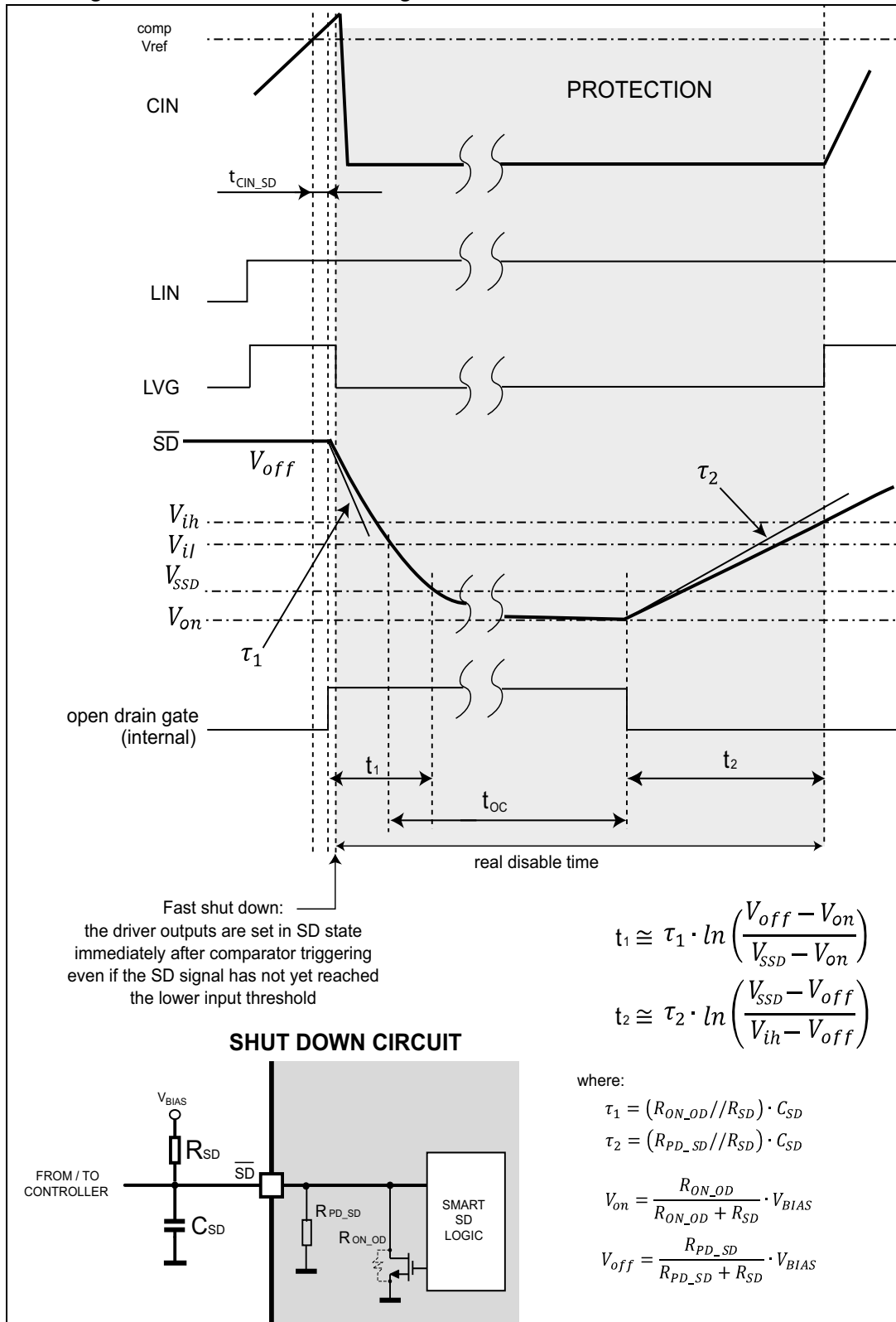

Note: $R_{ON_OD} = V_{OD} / 5 \text{ mA}$ see Table 9; $R_{PD_SD} (\text{typ}) = 5 \text{ V} / I_{SDh}$

In common over-current protection architectures the comparator output is usually connected to the \overline{SD} input and an RC network is connected to this \overline{SD} line in order to provide a mono-stable circuit, which implements a protection time that follows the fault condition.

Differently from the common fault detection systems, the device Smart shutdown architecture allows to immediately turn-off the outputs gate driver in case of fault, by minimizing the propagation delay between the fault detection event and the actual outputs switch-off. In fact the time delay between the fault and the outputs turn off is no more dependent on the RC value of the external network connected to the pin.

In the smart shutdown circuitry, the fault signal has a preferential path which directly switches off the outputs after the comparator triggering.

At the same time the internal logic turns on the open drain output and holds it on until the \overline{SD} voltage goes below the V_{SSD} threshold and t_{oc} time is elapsed.

The driver outputs restart following the input pins as soon as the voltage at the \overline{SD} pin reaches the higher threshold of the \overline{SD} logic input.

The Smart shutdown system provides the possibility to increase the time constant of the external RC network (that is the disable time after the fault event) up to very large values without increasing the delay time of the protection.

5 Typical application circuit

Figure 7. Typical application circuit

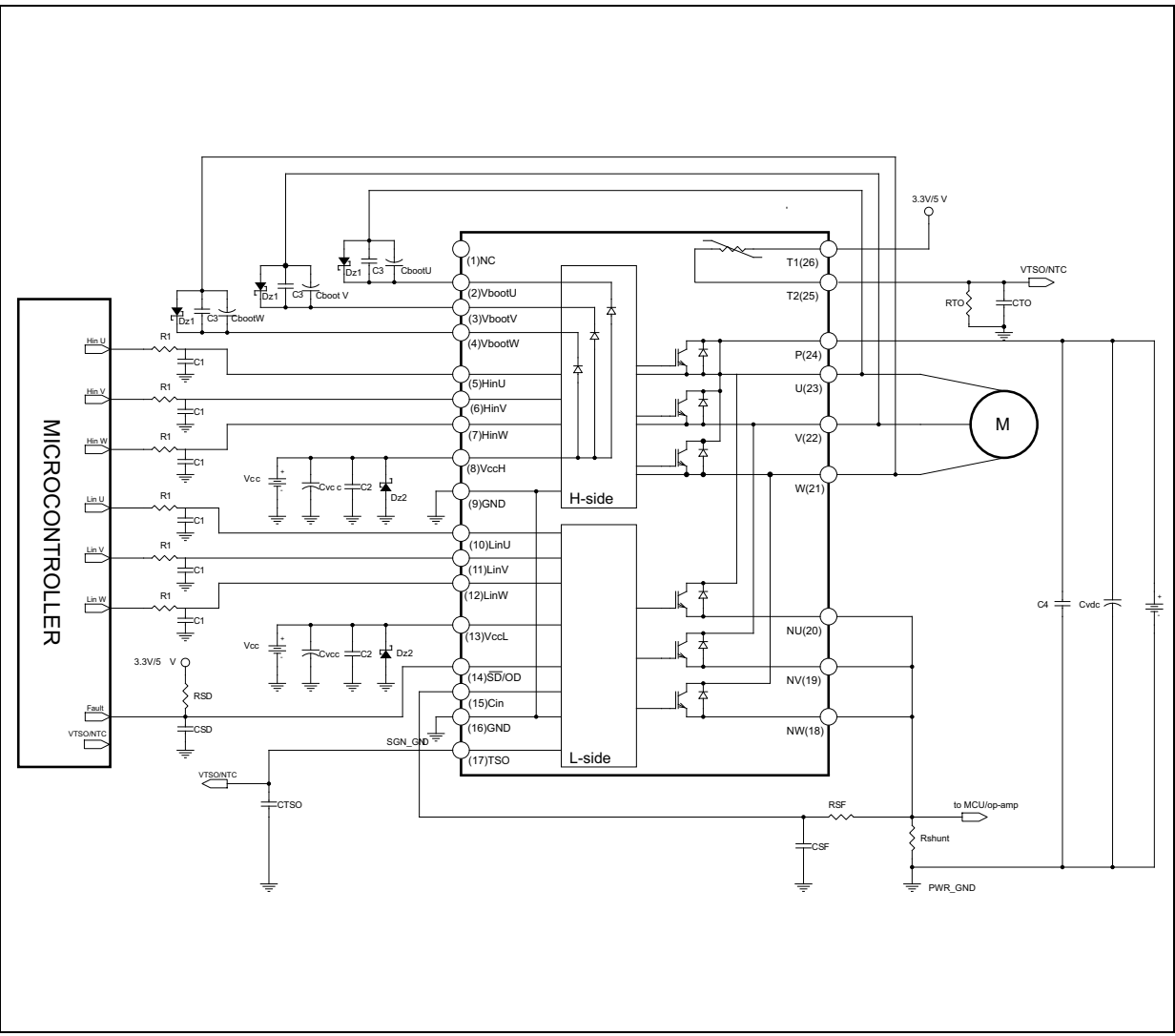

6 Recommendations

1. Input signals HIN, LIN are active-high logic. A 500 k Ω (typ.) pull-down resistor is built-in for each high side input. To prevent input signal oscillation, the wiring of each input should be as short as possible and the use of RC filters (R1, C1) on each input signal is suggested. The filters should be done with a time constant of about 100 ns and must be placed as close as possible to the IPM input pins.
2. The bypass capacitor Cvcc (aluminum or tantalum) is recommended to reduce the transient circuit demand on the power supply. In addition, a decoupling capacitor C₂ (100 to 220 nF, with low ESR and low ESL) is suggested, to reduce high frequency switching noise distributed on the power supply lines. It must be placed as close as possible to each Vcc pin and in parallel to the bypass capacitor.
3. The use of RC filter (RSF, CSF) for preventing protection circuit malfunction is recommended. The time constant (RSF x CSF) should be set to 1us and the filter must be placed as close as possible to the CIN pin.
4. The \overline{SD} is an input/output pin (open drain type if used as output). It should be pulled up to MCU power supply (3.3/5 V) by a resistor higher than 1.0 k Ω in order to keep I_{od} lower than 5 mA. The filter on SD has to be sized to get a desired re-starting time after a fault event and placed as close as possible to the \overline{SD} pin.
5. To increase the noise immunity of the TSO thermal sensor, it is recommended to parallel a decoupling capacitor C_{T_{TSO}} between 1nF and 10nF. Similarly, if the NTC thermistor is available and used, it is recommended to parallel a decoupling capacitor C_{OT} between 10nF and 100nF. In both cases, the capacitors must be placed close to the MCU.
6. The decoupling capacitor C₃ (100 to 220 nF, with low ESR and low ESL) in parallel with each C_{boot} is recommended to filter high frequency disturbances. Both C_{boot} and C₃ must be placed as close as possible to the U,V,W and V_{boot} pins. Bootstrap negative electrodes should be connected to U,V,W terminals directly and separated from the main output wires.
7. A Zener diode (Dz1) between each V_{cc} pin and GND, and in parallel (Dz2) with each Cboot is suggested in order to prevent overvoltage.
8. The decoupling capacitor C₄ (100 to 220 nF, with low ESR and low ESL) in parallel with the electrolytic capacitor Cvdc is recommended, in order to prevent surge destruction. Both capacitors C₄ and Cvdc should be placed as close as possible to the IPM (C₄ has priority over Cvdc).
9. By integrating an application-specific type HVIC inside the module, direct coupling to the MCU terminals without an opto-coupler is possible.
10. Low inductance shunt resistors should be used for phase leg current sensing
11. In order to avoid malfunctions, the wiring between N pins, the shunt resistor and PWR_GND should be as short as possible.
12. It is recommended to connect SGN_GND to PWR_GND at only one point (near the terminal of shunt resistor), in order to avoid any malfunction due to power ground fluctuation.

Table 11. Recommended operating conditions

Symbol	Parameter	Test condition	Min	Typ	Max	Unit
V_{PN}	Supply voltage	Applied between P-Nu, N _V , N _W		300	400	V
V_{CC}	Control supply voltage	Applied between V _{CC} -GND	13.5	15	18	V
V_{BS}	High side bias voltage	Applied between V _{BOOTi} -OUT _i for i = U, V, W	13		18	V
t_{dead}	Blanking time to prevent Arm-short	For each input signal	1.0			μs
f_{PWM}	PWM input signal	-40 °C < T _C < 100 °C -40 °C < T _j < 125 °C			20	kHz
T_C	Case operation temperature				100	°C

7 NTC thermistor

Table 12. NTC thermistor

Symbol	Parameter	Test condition	Min	Typ	Max	Unit
R ₂₅	Resistance	T = 25°C		85	-	kΩ
R ₁₂₅	Resistance	T = 125°C		2.6	-	kΩ
B	B-constant	T = 25°C to 100°C		4092	-	K
T	Operating temperature range		-40		125	°C

Figure 8. NTC resistance vs. temperature

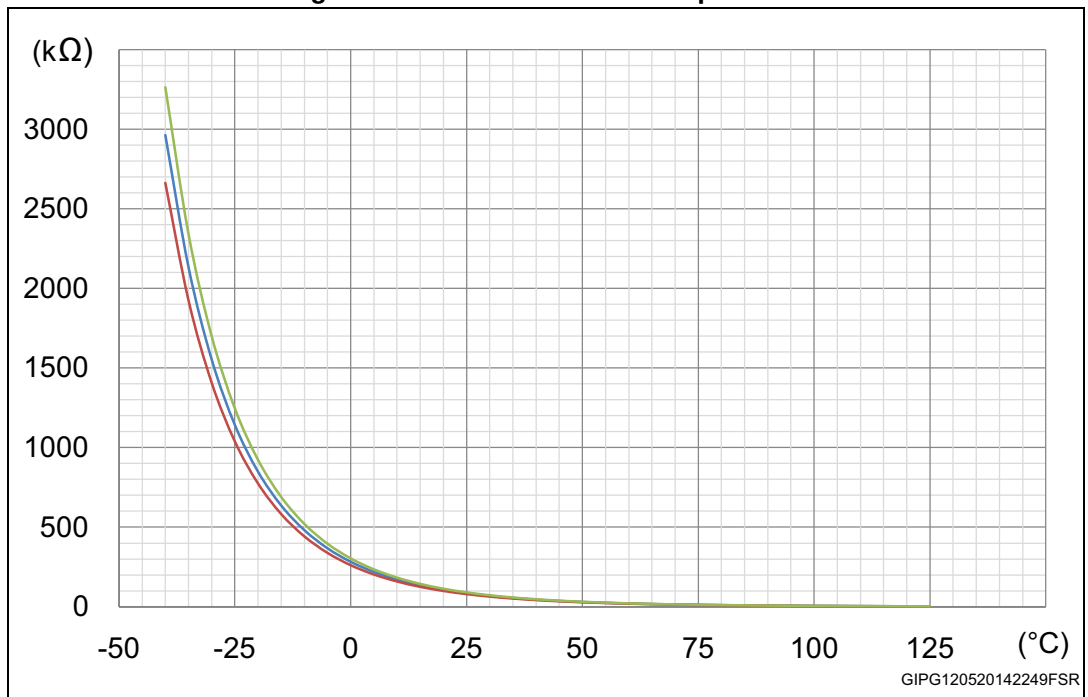
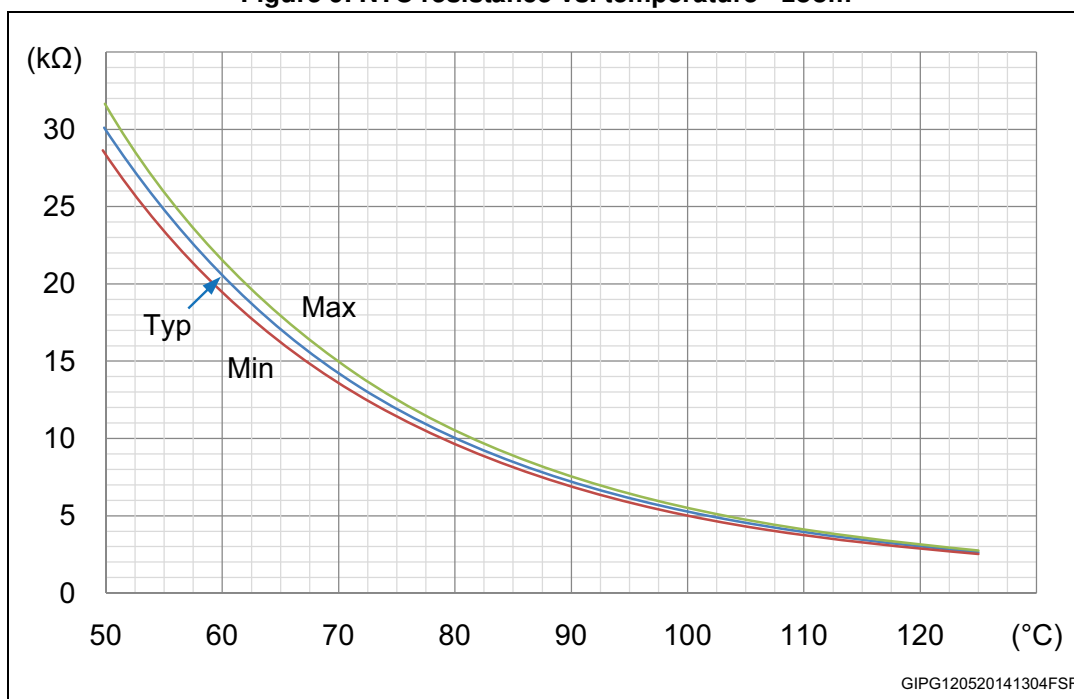
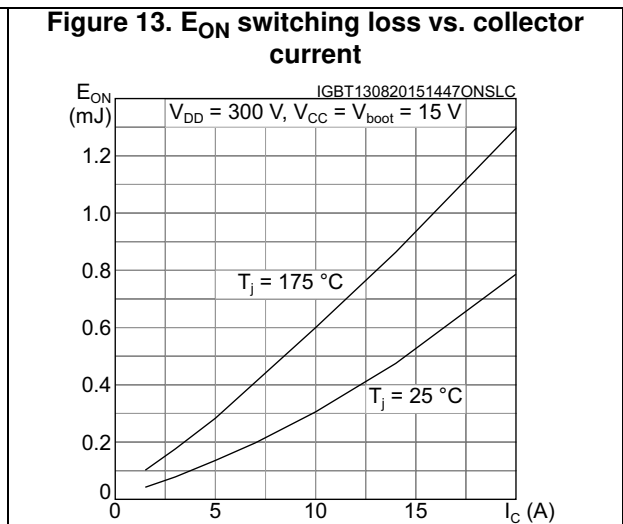
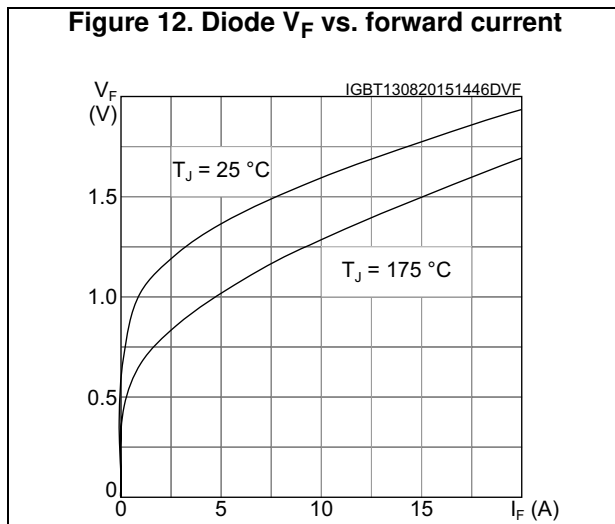
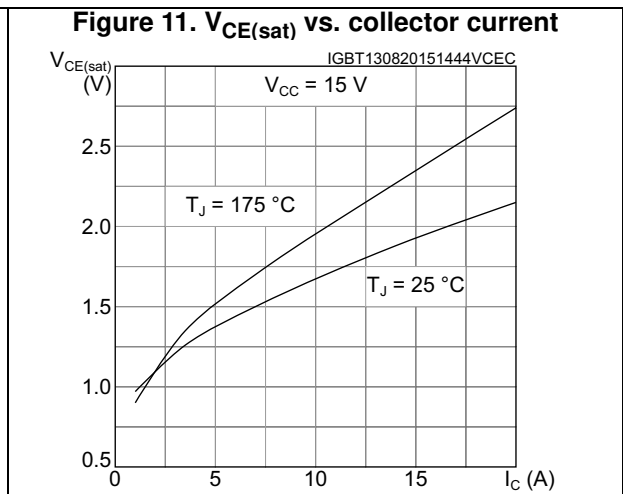
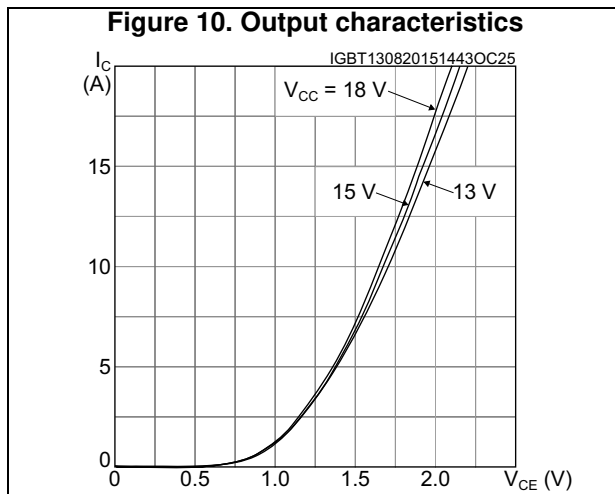
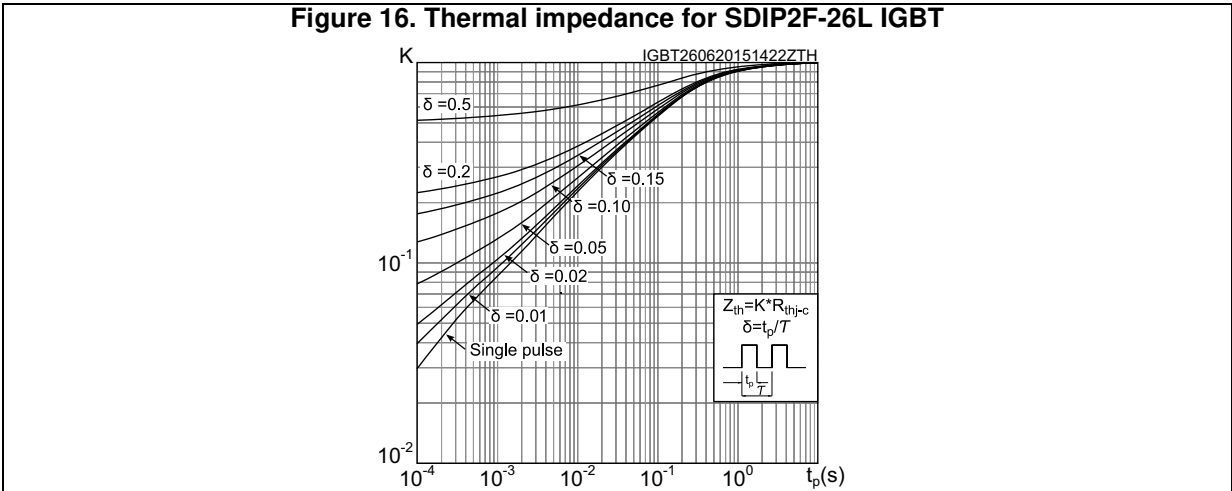
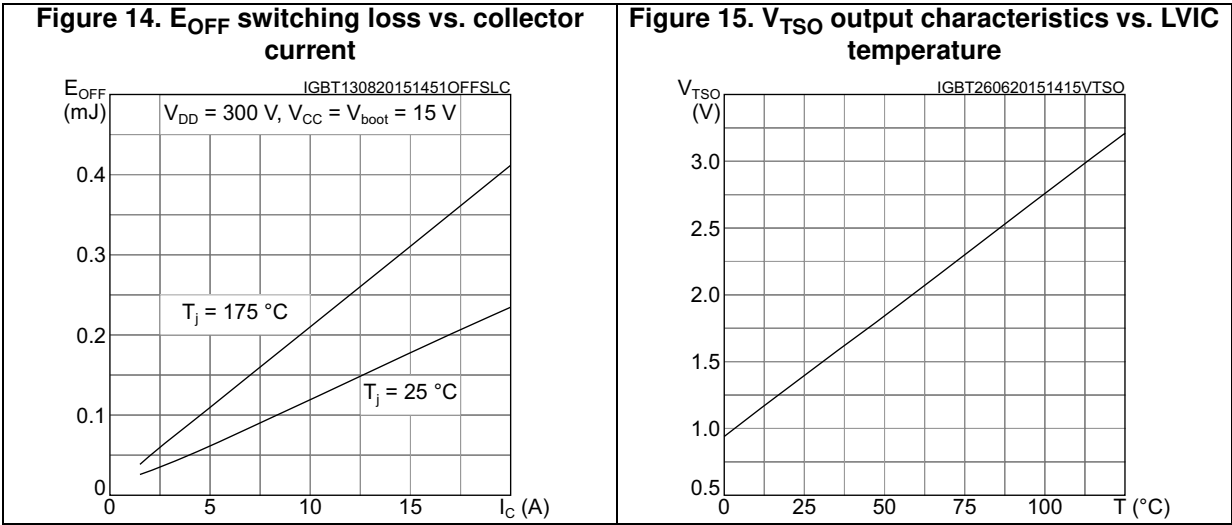

Figure 9. NTC resistance vs. temperature - zoom



8 Electrical characteristics (curves)





9 Package information

In order to meet environmental requirements, ST offers these devices in different grades of ECOPACK[®] packages, depending on their level of environmental compliance. ECOPACK[®] specifications, grade definitions and product status are available at: www.st.com. ECOPACK[®] is an ST trademark.

Figure 17. SDIP2F-26L type L package outline

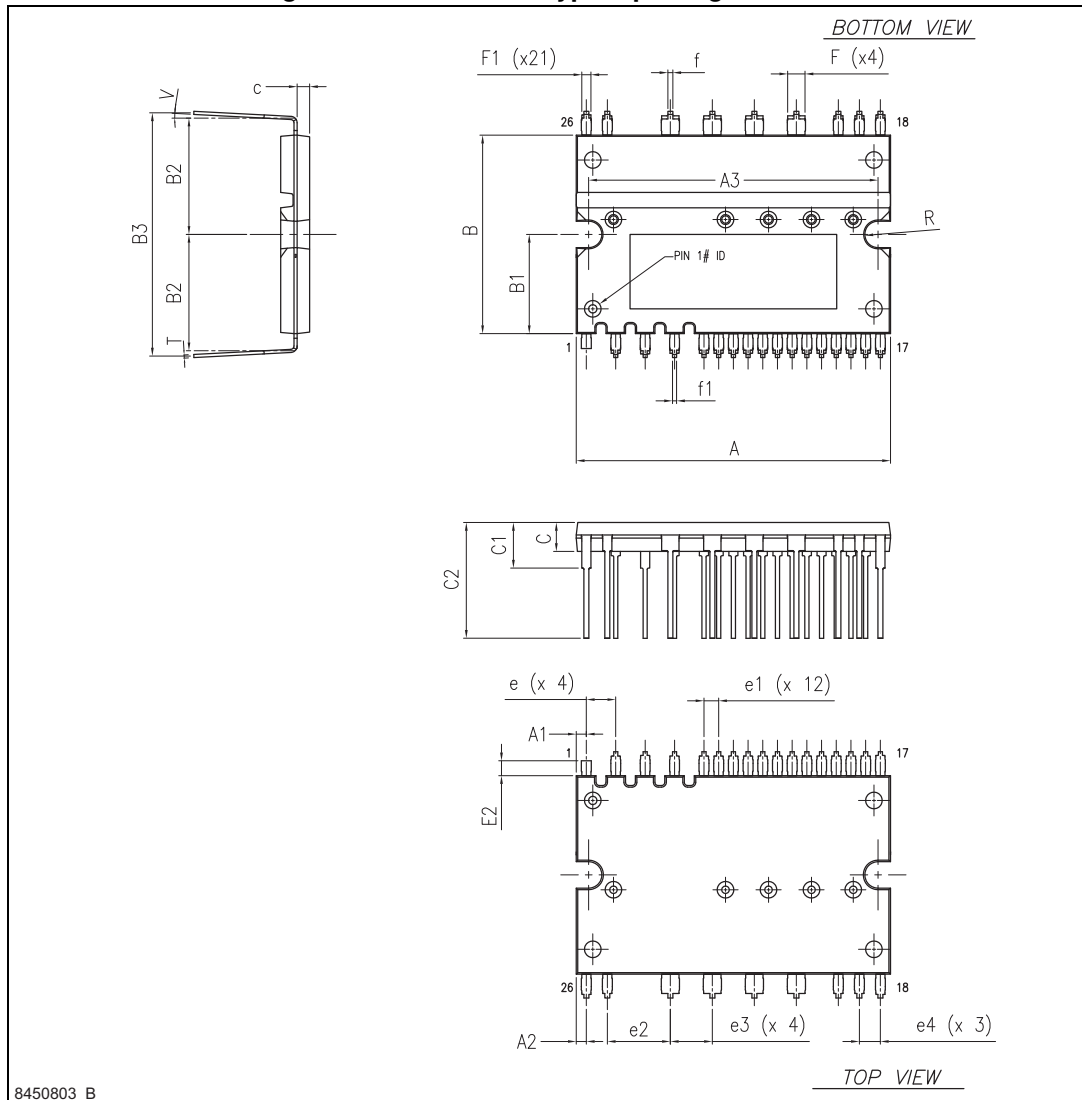

Table 13. SDIP2F-26L type L package mechanical data⁽¹⁾

Ref.	Dimensions	Ref.	Dimensions	Ref.	Dimensions
A	38.00 ± 0.50	B3	29.40 ± 0.50	e4	2.54 ± 0.20
A1	1.22 ± 0.25	C	3.50 ± 0.20	f	0.60 ± 0.15
A2	1.22 ± 0.25	C1	5.50 ± 0.50	f1	0.50 ± 0.15
A3	35.00 ± 0.30	C2	14.00 ± 0.50	F	2.10 ± 0.15
c	1.50 ± 0.05	e	3.556 ± 0.200	F1	1.10 ± 0.15
B	24.00 ± 0.50	e1	1.778 ± 0.200	R	1.60 ± 0.20
B1	12.00	e2	7.62 ± 0.20	T	0.400 ± 0.025
B2	14.40 ± 0.50	e3	5.08 ± 0.20	V	0° / 5°

1. All dimensions are expressed in millimeters.

10 Revision history

Table 14. Document revision history

Date	Revision	Changes
20-Jun-2014	1	Initial release.
27-Aug-2014	2	Updated Table 1: Device summary.
28-Apr-2015	3	Updated title, features and description in cover page. Updated Table 3: Inverter parts and Table 6: Thermal data.
13-Aug-2015	4	Text and formatting edits throughout document On cover page: - updated Features In Section 2: Absolute maximum ratings - updated Table 3, Table 4, Table 5 and Table 6 In Section 3: Electrical characteristics - updated Table 7, Table 8 and Table 9 In Section 6: Recommendations - added Table 11 Added Section 8: Electrical characteristics (curves)
03-Sep-2015	5	Modified: title and Figure 6 Minor text changes
22-Dec-2015	6	Document status promoted from preliminary to production data. Minor text changes.

IMPORTANT NOTICE – PLEASE READ CAREFULLY

STMicroelectronics NV and its subsidiaries ("ST") reserve the right to make changes, corrections, enhancements, modifications, and improvements to ST products and/or to this document at any time without notice. Purchasers should obtain the latest relevant information on ST products before placing orders. ST products are sold pursuant to ST's terms and conditions of sale in place at the time of order acknowledgement.

Purchasers are solely responsible for the choice, selection, and use of ST products and ST assumes no liability for application assistance or the design of Purchasers' products.

No license, express or implied, to any intellectual property right is granted by ST herein.

Resale of ST products with provisions different from the information set forth herein shall void any warranty granted by ST for such product.

ST and the ST logo are trademarks of ST. All other product or service names are the property of their respective owners.

Information in this document supersedes and replaces information previously supplied in any prior versions of this document.

© 2015 STMicroelectronics – All rights reserved

