



Chipsmall Limited consists of a professional team with an average of over 10 year of expertise in the distribution of electronic components. Based in Hongkong, we have already established firm and mutual-benefit business relationships with customers from,Europe,America and south Asia,supplying obsolete and hard-to-find components to meet their specific needs.

With the principle of “Quality Parts,Customers Priority,Honest Operation,and Considerate Service”,our business mainly focus on the distribution of electronic components. Line cards we deal with include Microchip,ALPS,ROHM,Xilinx,Pulse,ON,Everlight and Freescale. Main products comprise IC,Modules,Potentiometer,IC Socket,Relay,Connector.Our parts cover such applications as commercial,industrial, and automotives areas.

We are looking forward to setting up business relationship with you and hope to provide you with the best service and solution. Let us make a better world for our industry!



Contact us

Tel: +86-755-8981 8866 Fax: +86-755-8427 6832

Email & Skype: info@chipsmall.com Web: www.chipsmall.com

Address: A1208, Overseas Decoration Building, #122 Zhenhua RD., Futian, Shenzhen, China



SLLIMM™-nano (small low-loss intelligent molded module) IPM, 3 A - 600 V 3-phase IGBT inverter bridge

Datasheet - preliminary data

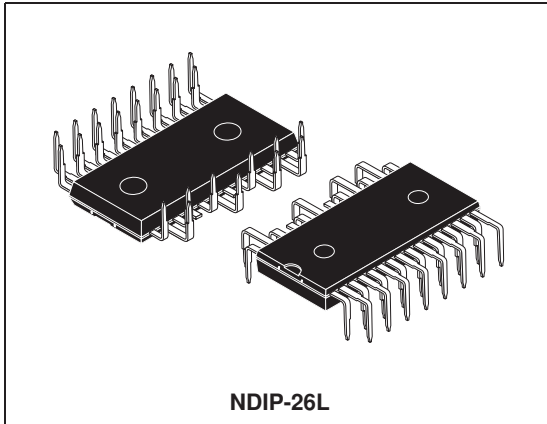

Features

- IPM 3 A, 600 V, 3-phase IGBT inverter bridge including control ICs for gate driving and freewheeling diodes
- Optimized for low electromagnetic interference
- $V_{CE(sat)}$ negative temperature coefficient
- 3.3 V, 5 V, 15 V CMOS/TTL inputs comparators with hysteresis and pull down/pull up resistors
- Undervoltage lockout
- Internal bootstrap diode
- Interlocking function
- Smart shutdown function
- Comparator for fault protection against overtemperature and overcurrent
- Op amp for advanced current sensing
- Optimized pinout for easy board layout
- ESD voltage (HBM C=100 pF, R=1.5 kΩ) up to ±2 kV

Applications

- 3-phase inverters for motor drives
- Dish washers, refrigerator compressors, heating systems, air-conditioning fans, draining and recirculation pumps

Description

This intelligent power module implements a compact, high performance AC motor drive in a simple, rugged design. It is composed of six IGBTs with freewheeling diodes and three half-bridge HVICs for gate driving, providing low electromagnetic interference (EMI) characteristics with optimized switching speed. The package is optimized for thermal performance and compactness in built-in motor applications, or other low power applications where assembly space is limited. This IPM includes an operational amplifier, completely uncommitted, and a comparator that can be used to design a fast and efficient protection circuit. SLLIMM™ is a trademark of STMicroelectronics.

Table 1. Device summary

Order code	Marking	Package	Packaging
STGIPN3H60-E	GIPN3H60-E	NDIP-26L	Tube

Contents

1	Internal schematic diagram and pin configuration	3
2	Electrical ratings	6
2.1	Absolute maximum ratings	6
2.2	Thermal data	7
3	Electrical characteristics	8
3.1	Control part	10
3.2	Waveform definitions	13
4	Smart shutdown function	14
5	Application information	16
5.1	Recommendations	17
6	Package mechanical data	18
7	Revision history	21

1 Internal schematic diagram and pin configuration

Figure 1. Internal schematic diagram

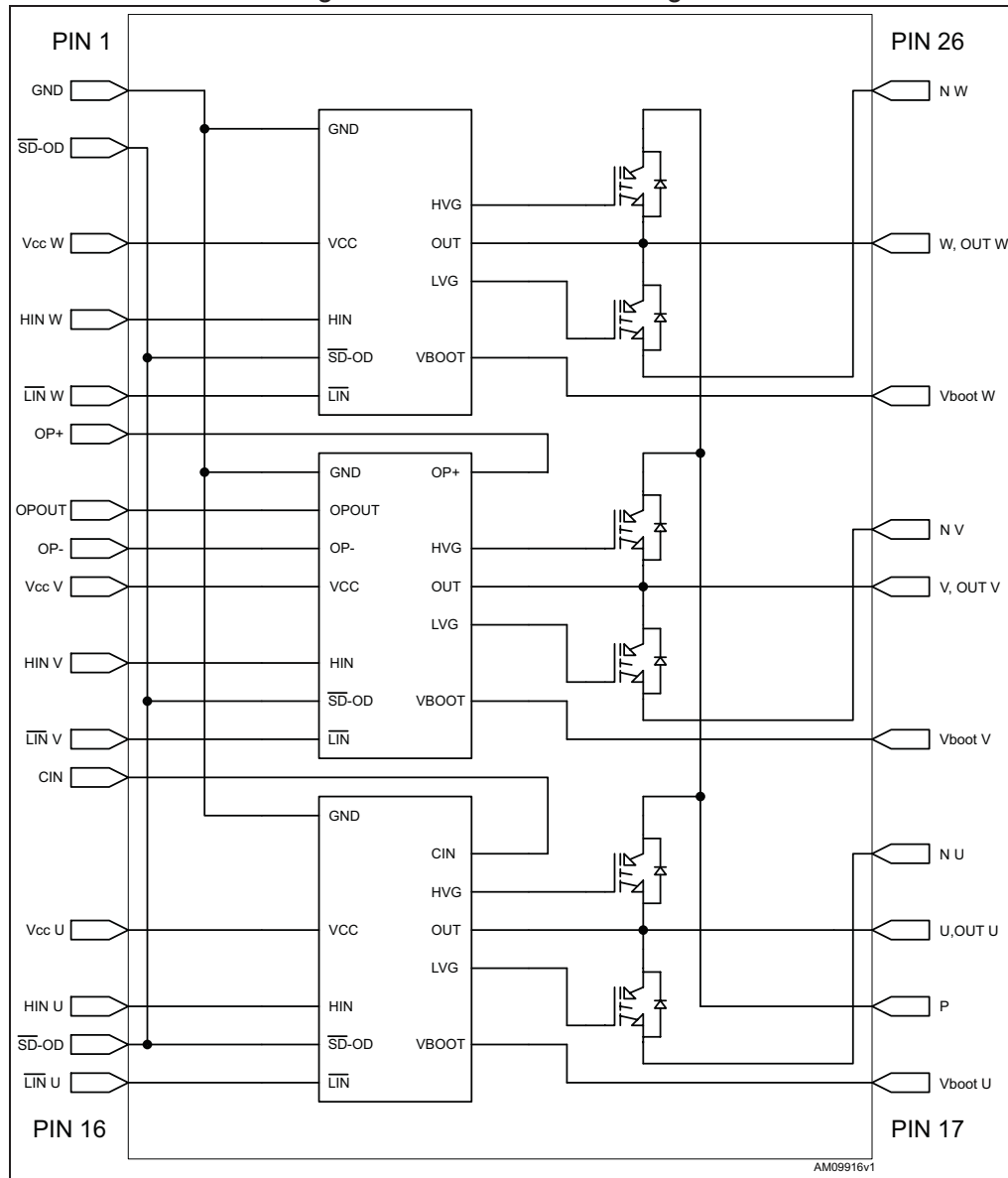
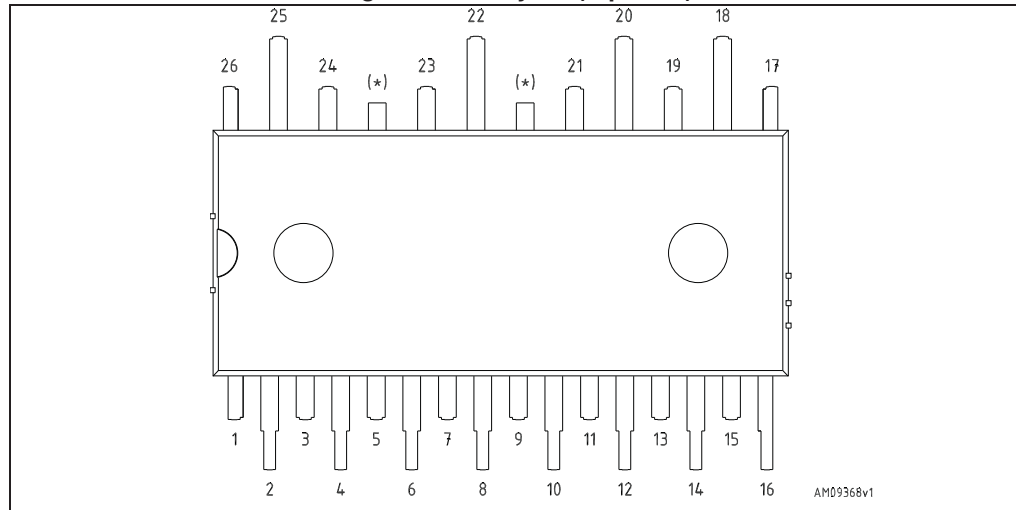

Table 2. Pin description

Pin	Symbol	Description
1	GND	Ground
2	$\overline{\text{SD}} / \text{OD}$	Shut down logic input (active low) / open drain (comparator output)
3	$V_{\text{CC W}}$	Low voltage power supply W phase
4	HIN W	High side logic input for W phase
5	$\overline{\text{LIN}} \text{ W}$	Low side logic input for W phase
6	OP+	Op amp non inverting input
7	OP _{OUT}	Op amp output
8	OP-	Op amp inverting input
9	$V_{\text{CC V}}$	Low voltage power supply V phase
10	HIN V	High side logic input for V phase
11	$\overline{\text{LIN}} \text{ V}$	Low side logic input for V phase
12	CIN	Comparator input
13	$V_{\text{CC U}}$	Low voltage power supply for U phase
14	HIN U	High side logic input for U phase
15	$\overline{\text{SD}} / \text{OD}$	Shut down logic input (active low) / open drain (comparator output)
16	$\overline{\text{LIN}} \text{ U}$	Low side logic input for U phase
17	$V_{\text{BOOT U}}$	Bootstrap voltage for U phase
18	P	Positive DC input
19	U, OUT _U	U phase output
20	N _U	Negative DC input for U phase
21	$V_{\text{BOOT V}}$	Bootstrap voltage for V phase
22	V, OUT _V	V phase output
23	N _V	Negative DC input for V phase
24	$V_{\text{BOOT W}}$	Bootstrap voltage for W phase
25	W, OUT _W	W phase output
26	N _W	Negative DC input for W phase

Figure 2. Pin layout (top view)



(*) Dummy pin internally connected to P (positive DC input).

2 Electrical ratings

2.1 Absolute maximum ratings

Table 3. Inverter part

Symbol	Parameter	Value	Unit
V_{CES}	Each IGBT collector emitter voltage ($V_{IN}^{(1)} = 0$)	600	V
$\pm I_C^{(2)}$	Each IGBT continuous collector current at $T_C = 25^\circ\text{C}$	3	A
$\pm I_{CP}^{(3)}$	Each IGBT pulsed collector current	18	A
P_{TOT}	Each IGBT total dissipation at $T_C = 25^\circ\text{C}$	8	W

1. Applied between HIN_i , \overline{LIN}_i and G_{ND} for $i = U, V, W$
2. Calculated according to the iterative formula:

$$I_C(T_C) = \frac{T_{j(max)} - T_C}{R_{thj-c} \times V_{CE(sat)(max)}(T_{j(max)}, I_C(T_C))}$$

3. Pulse width limited by max junction temperature

Table 4. Control part

Symbol	Parameter	Min.	Max.	Unit
V_{OUT}	Output voltage applied between OUT_U , OUT_V , OUT_W - GND	$V_{boot} - 21$	$V_{boot} + 0.3$	V
V_{CC}	Low voltage power supply	- 0.3	21	V
V_{CIN}	Comparator input voltage	- 0.3	$V_{CC} + 0.3$	V
V_{op+}	OPAMP non-inverting input	- 0.3	$V_{CC} + 0.3$	V
V_{op-}	OPAMP inverting input	- 0.3	$V_{CC} + 0.3$	V
V_{boot}	Bootstrap voltage	- 0.3	620	V
V_{IN}	Logic input voltage applied between HIN , \overline{LIN} and GND	- 0.3	15	V
$V_{SD/OD}$	Open drain voltage	- 0.3	15	V
$\Delta V_{OUT/dT}$	Allowed output slew rate		50	V/ns

Table 5. Total system

Symbol	Parameter	Value	Unit
V_{ISO}	Isolation withstand voltage applied between each pin and heatsink plate (AC voltage, $t = 60$ sec.)	1000	V
T_j	Power chips operating junction temperature	-40 to 150	$^\circ\text{C}$
T_C	Module case operation temperature	-40 to 125	$^\circ\text{C}$

2.2 Thermal data

Table 6. Thermal data

Symbol	Parameter	Value	Unit
R_{thJA}	Thermal resistance junction-ambient	50	°C/W

3 Electrical characteristics

$T_J = 25\text{ °C}$ unless otherwise specified.

Table 7. Inverter part

Symbol	Parameter	Test conditions	Min.	Typ.	Max.	Unit
$V_{CE(sat)}$	Collector-emitter saturation voltage	$V_{CC} = V_{boot} = 15\text{ V}$, $V_{IN}^{(1)} = 0 - 5\text{ V}$, $I_C = 1\text{ A}$	-	2.15	2.6	V
		$V_{CC} = V_{boot} = 15\text{ V}$, $V_{IN}^{(1)} = 0 - 5\text{ V}$, $I_C = 1\text{ A}$, $T_J = 125\text{ °C}$	-	1.65		
I_{CES}	Collector-cut off current ($V_{IN}^{(1)} = 0$ "logic state")	$V_{CE} = 550\text{ V}$, $V_{CC} = V_{Boot} = 15\text{ V}$	-		250	μA
V_F	Diode forward voltage	$V_{IN}^{(1)} = 0$ "logic state", $I_C = 1\text{ A}$	-		1.7	V
Inductive load switching time and energy						
t_{on}	Turn-on time	$V_{DD} = 300\text{ V}$, $V_{CC} = V_{boot} = 15\text{ V}$, $V_{IN}^{(1)} = 0 - 5\text{ V}$, $I_C = 1\text{ A}$ (see Figure 4)	-	275		ns
$t_{c(on)}$	Crossover time (on)		-	90		
t_{off}	Turn-off time		-	890		
$t_{c(off)}$	Crossover time (off)		-	125		
t_{rr}	Reverse recovery time		-	50		
E_{on}	Turn-on switching losses		-	18		μJ
E_{off}	Turn-off switching losses		-	13		

1. Applied between HIN_i , \overline{LIN}_i and G_{ND} for $i = U, V, W$ (LIN inputs are active-low).

Note: t_{ON} and t_{OFF} include the propagation delay time of the internal drive. $t_{C(ON)}$ and $t_{C(OFF)}$ are the switching time of IGBT itself under the internally given gate driving condition.

Figure 3. Switching time test circuit

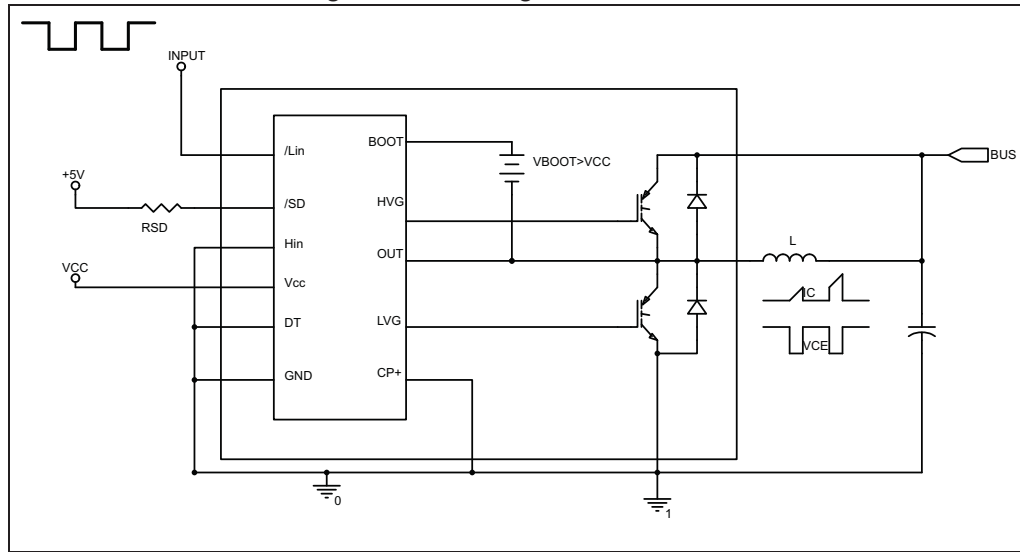
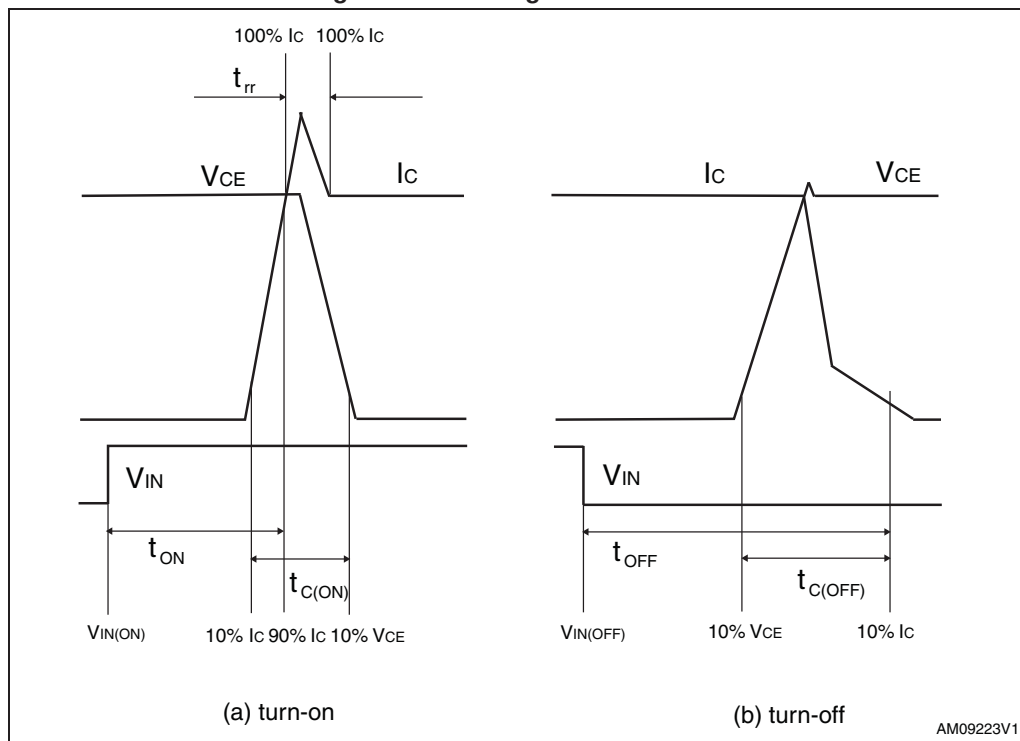

Figure 4. Switching time definition



Note: Figure 4 "Switching time definition" refers to H_{IN} inputs (active high). For \overline{L}_{IN} inputs (active low), V_{IN} polarity must be inverted for turn-on and turn-off.

3.1 Control part

Table 8. Low voltage power supply ($V_{CC} = 15\text{ V}$ unless otherwise specified)

Symbol	Parameter	Test conditions	Min.	Typ.	Max.	Unit
V_{CC_hys}	V_{CC} UV hysteresis		1.2	1.5	1.8	V
V_{CC_thON}	V_{CC} UV turn ON threshold		11.5	12	12.5	V
V_{CC_thOFF}	V_{CC} UV turn OFF threshold		10	10.5	11	V
I_{qccu}	Undervoltage quiescent supply current	$V_{CC} = 10\text{ V}$ $\overline{SD/OD} = 5\text{ V}$; $\overline{LIN} = 5\text{ V}$; $H_{IN} = 0$, $C_{IN} = 0$			150	μA
I_{qcc}	Quiescent current	$V_{CC} = 15\text{ V}$ $\overline{SD/OD} = 5\text{ V}$; $\overline{LIN} = 5\text{ V}$ $H_{IN} = 0$, $C_{IN} = 0$			1	mA
V_{ref}	Internal comparator (CIN) reference voltage		0.5	0.54	0.58	V

Table 9. Bootstrapped voltage ($V_{CC} = 15\text{ V}$ unless otherwise specified)

Symbol	Parameter	Test conditions	Min.	Typ.	Max.	Unit
V_{BS_hys}	V_{BS} UV hysteresis		1.2	1.5	1.8	V
V_{BS_thON}	V_{BS} UV turn ON threshold		11.1	11.5	12.1	V
V_{BS_thOFF}	V_{BS} UV turn OFF threshold		9.8	10	10.6	V
I_{QBSU}	Undervoltage V_{BS} quiescent current	$V_{BS} < 9\text{ V}$ $\overline{SD/OD} = 5\text{ V}$; \overline{LIN} and $H_{IN} = 5\text{ V}$; $C_{IN} = 0$		70	110	μA
I_{QBS}	V_{BS} quiescent current	$V_{BS} = 15\text{ V}$ $\overline{SD/OD} = 5\text{ V}$; \overline{LIN} and $H_{IN} = 5\text{ V}$; $C_{IN} = 0$		200	300	μA
$R_{DS(on)}$	Bootstrap driver on resistance	LVG ON		120		Ω

Table 10. Logic inputs ($V_{CC} = 15\text{ V}$ unless otherwise specified)

Symbol	Parameter	Test conditions	Min.	Typ.	Max.	Unit
V_{il}	Low logic level voltage		0.8		1.1	V
V_{ih}	High logic level voltage		1.9		2.25	V
I_{HINh}	HIN logic "1" input bias current	$H_{IN} = 15\text{ V}$	110	175	260	μA
I_{HINl}	HIN logic "0" input bias current	$H_{IN} = 0\text{ V}$			1	μA
I_{LINl}	\overline{LIN} logic "1" input bias current	$\overline{LIN} = 0\text{ V}$	3	6	20	μA
I_{LINh}	\overline{LIN} logic "0" input bias current	$\overline{LIN} = 15\text{ V}$			1	μA
I_{SDh}	\overline{SD} logic "0" input bias current	$\overline{SD} = 15\text{ V}$	30	120	300	μA

Table 10. Logic inputs ($V_{CC} = 15\text{ V}$ unless otherwise specified)

Symbol	Parameter	Test conditions	Min.	Typ.	Max.	Unit
I_{SDI}	SD logic "1" input bias current	$\overline{SD} = 0\text{ V}$			3	μA
Dt	Dead time	see <i>Figure 5</i>		180		ns

Table 11. OPAMP characteristics ($V_{CC} = 15\text{ V}$ unless otherwise specified)

Symbol	Parameter	Test condition	Min.	Typ.	Max.	Unit
V_{io}	Input offset voltage	$V_{ic} = 0\text{ V}$, $V_o = 7.5\text{ V}$			6	mV
I_{io}	Input offset current	$V_{ic} = 0\text{ V}$, $V_o = 7.5\text{ V}$		4	40	nA
I_{ib}	Input bias current ⁽¹⁾			100	200	nA
V_{icm}	Input common mode voltage range		0			V
V_{OL}	Low level output voltage	$R_L = 10\text{ kW}$ to V_{CC}		75	150	mV
V_{OH}	High level output voltage	$R_L = 10\text{ kW}$ to GND	14	14.7		V
I_o	Output short-circuit current	Source, $V_{id} = +1$; $V_o = 0\text{ V}$	16	30		mA
		Sink, $V_{id} = -1$; $V_o = V_{CC}$	50	80		mA
SR	Slew rate	$V_i = 1 - 4\text{ V}$; $C_L = 100\text{ pF}$; unity gain	2.5	3.8		V/ μs
GBWP	Gain bandwidth product	$V_o = 7.5\text{ V}$	8	12		MHz
A_{vd}	Large signal voltage gain	$R_L = 2\text{ kW}$	70	85		dB
SVR	Supply voltage rejection ratio	vs. V_{CC}	60	75		dB
CMRR	Common mode rejection ratio		55	70		dB

1. The direction of input current is out of the IC.

Table 12. Sense comparator characteristics ($V_{CC} = 15\text{ V}$ unless otherwise specified)

Symbol	Parameter	Test conditions	Min.	Typ.	Max.	Unit
I_{ib}	Input bias current	$V_{CIN} = 1\text{ V}$			3	μA
V_{ol}	Open drain low level output voltage	$I_{od} = 3\text{ mA}$			0.5	V
t_{d_comp}	Comparator delay	\overline{SD}/OD pulled to 5 V through 100 k Ω resistor		90	130	ns
SR	Slew rate	$C_L = 180\text{ pF}$; $R_{pu} = 5\text{ k}\Omega$		60		V/ μsec
t_{sd}	Shutdown to high / low side driver propagation delay	$V_{OUT} = 0$, $V_{boot} = V_{CC}$, $V_{IN} = 0$ to 3.3 V	50	125	200	ns
t_{isd}	Comparator triggering to high / low side driver turn-off propagation delay	Measured applying a voltage step from 0 V to 3.3 V to pin CIN	50	200	250	

Table 13. Truth table

Condition	Logic input (V _I)			Output	
	$\overline{\text{SD/OD}}$	LIN	HIN	LVG	HVG
Shutdown enable half-bridge tri-state	L	X	X	L	L
Interlocking half-bridge tri-state	H	L	H	L	L
0 "logic state" half-bridge tri-state	H	H	L	L	L
1 "logic state" low side direct driving	H	L	L	H	L
1 "logic state" high side direct driving	H	H	H	L	H

Note: X: don't care

3.2 Waveform definitions

Figure 5. Dead time and interlocking waveform definitions

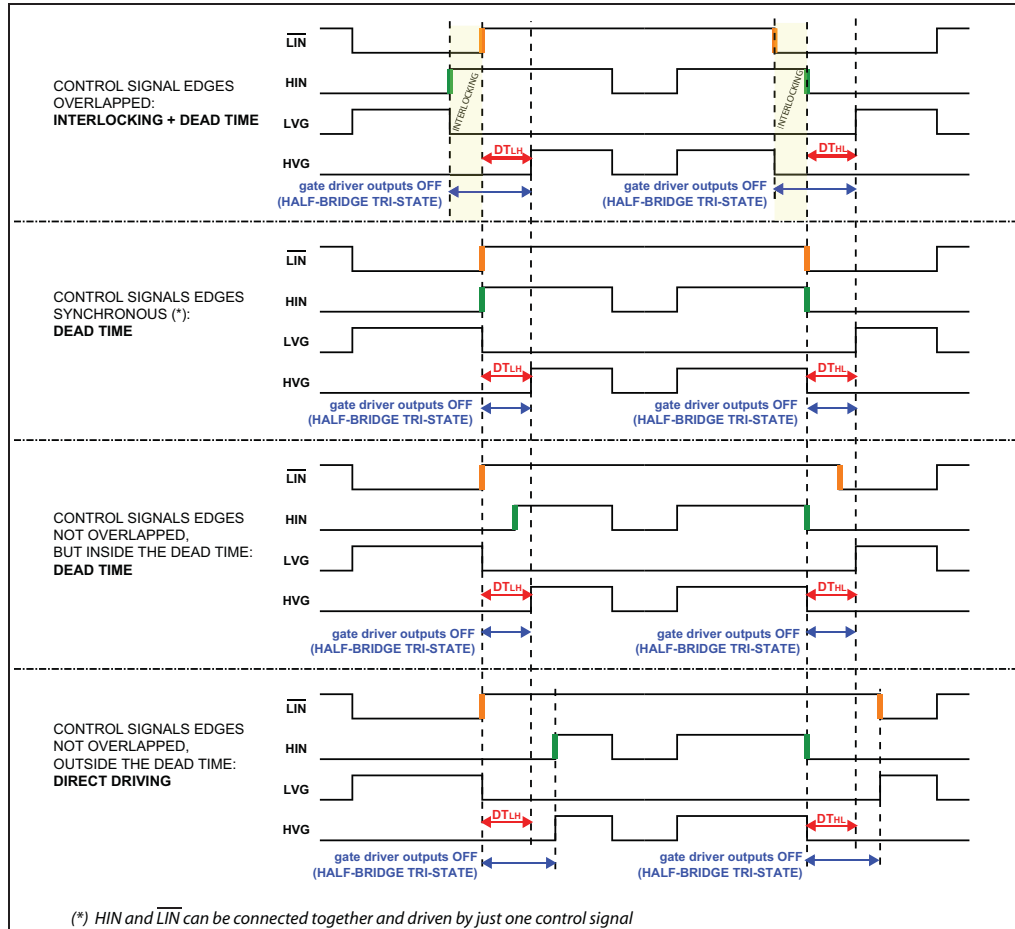

4 Smart shutdown function

The STGIPN3H60-E integrates a comparator for fault sensing purposes. The comparator non-inverting input (CIN) can be connected to an external shunt resistor in order to implement a simple overcurrent protection function. When the comparator triggers, the device is set in shutdown state and both its outputs are set to low-level leading the half bridge in 3-state. In the common overcurrent protection architectures the comparator output is usually connected to the shutdown input through a RC network, in order to provide a mono-stable circuit, which implements a protection time that follows the fault condition. Our smart shutdown architecture allows to immediately turn-off the output gate driver in case of overcurrent, the fault signal has a preferential path which directly switches off the outputs. The time delay between the fault and the outputs turn-off is no more dependent on the RC values of the external network connected to the shutdown pin. At the same time the internal logic turns on the open-drain output and holds it on until the shutdown voltage goes below the logic input lower threshold. Finally the smart shutdown function provides the possibility to increase the real disable time without increasing the constant time of the external RC network.

Figure 6. Smart shutdown timing waveforms

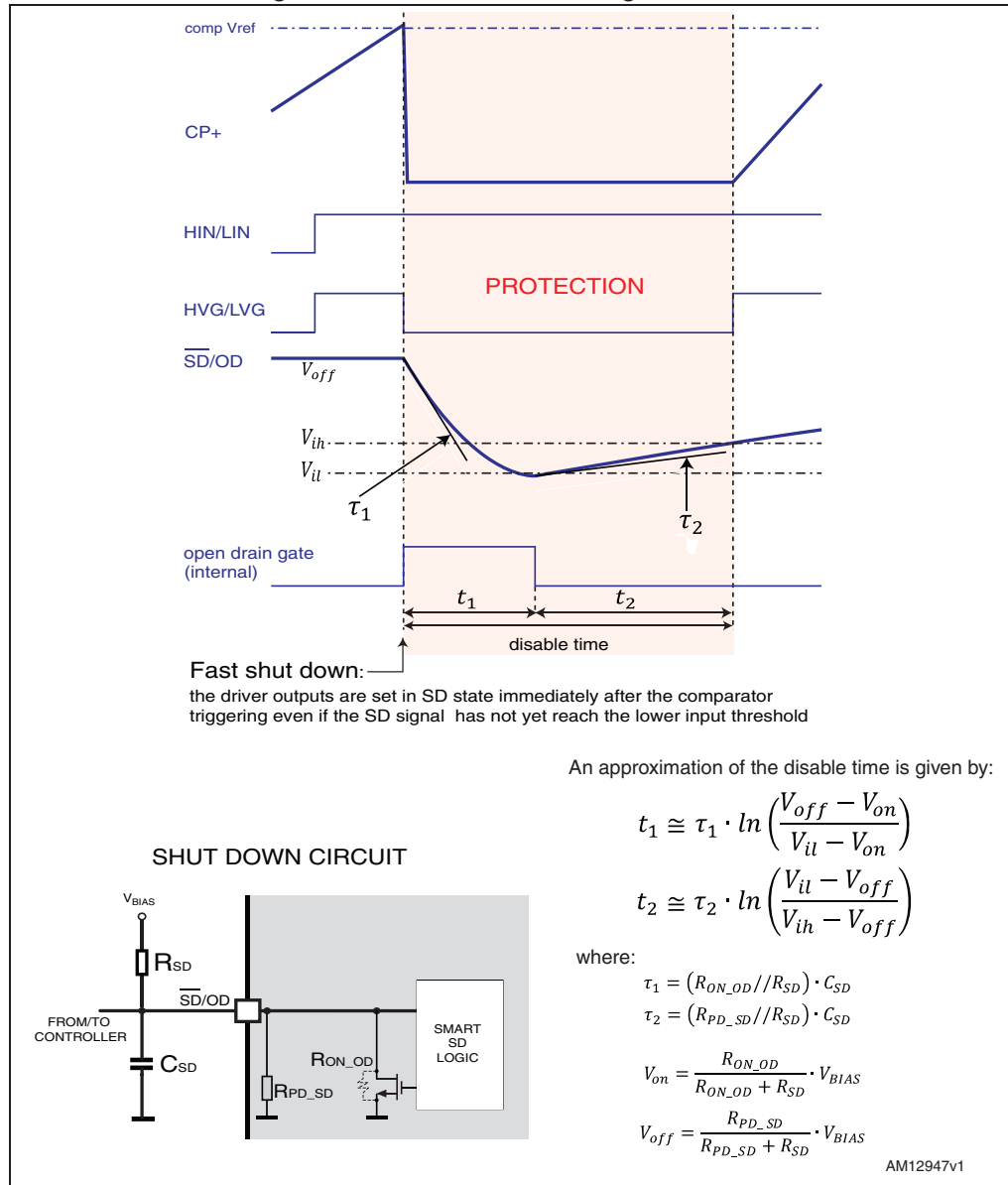

Please refer to [Table 12](#) for internal propagation delay time details.

5 Application information

Figure 7. Typical application circuit

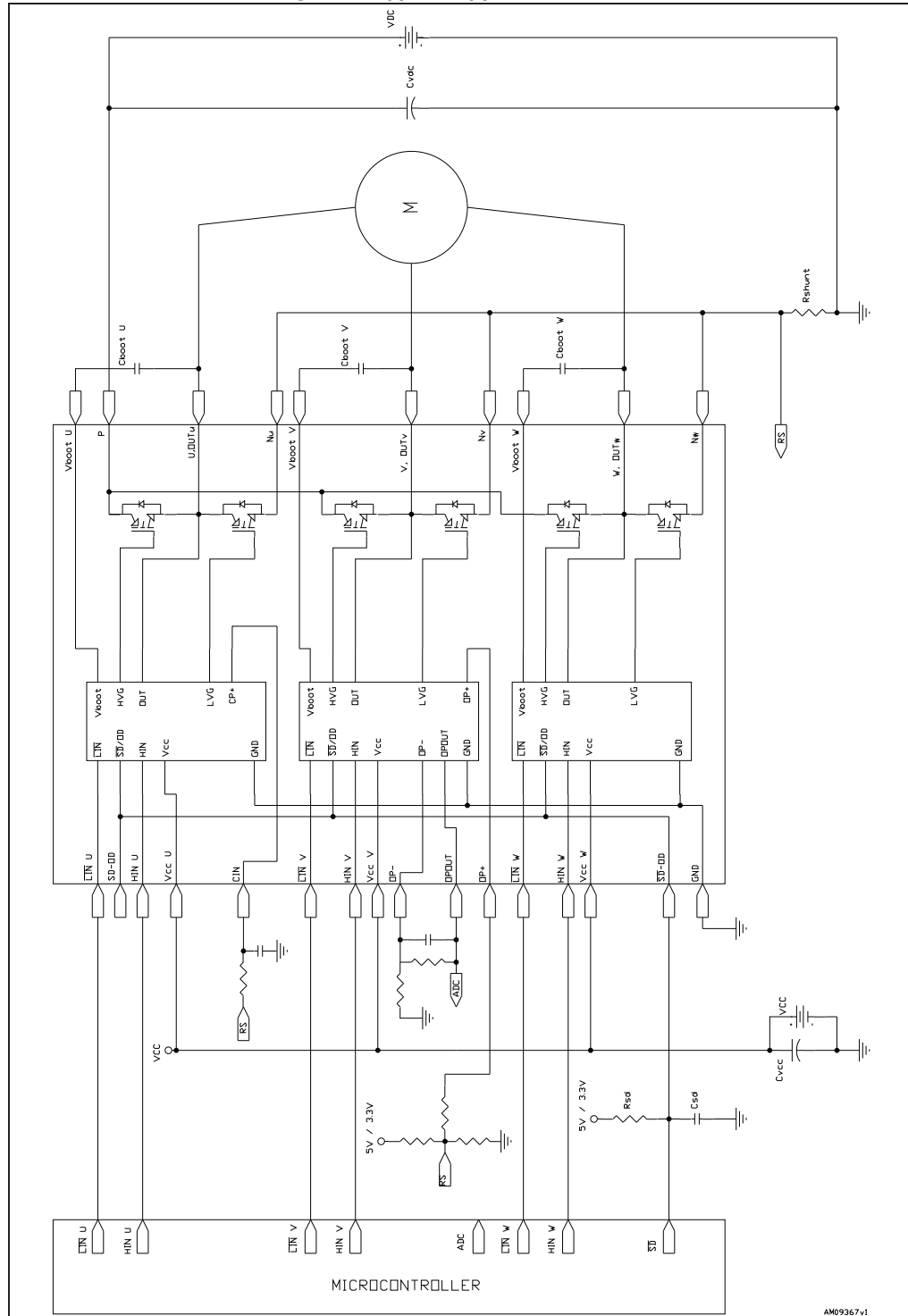

5.1 Recommendations

- Input signal HIN is active high logic. An 85 k Ω (typ.) pull-down resistor is built-in for each high side input. If an external RC filter is used for noise immunity, attention should be given to the variation of the input signal level.
- Input signal LIN is active low logic. A 720 k Ω (typ.) pull-up resistor, connected to an internal 5 V regulator through a diode, is built-in for each low side input.
- To prevent input signal oscillation, the wiring of each input should be as short as possible.
- By integrating an application-specific type HVIC inside the module, direct coupling to the MCU terminals without an opto-coupler is possible.
- Each capacitor should be located as close as possible to the pins of the IPM.
- Low inductance shunt resistors should be used for phase leg current sensing.
- Electrolytic bus capacitors should be mounted as close to the module bus terminals as possible. Additional high frequency ceramic capacitors mounted close to the module pins will further improve performance.
- The SD/OD signal should be pulled up to 5 V / 3.3 V with an external resistor (see [Section 4: Smart shutdown function](#) for detailed info).

Table 14. Recommended operating conditions

Symbol	Parameter	Test conditions	Min.	Typ.	Max.	Unit
V _{PN}	Supply voltage	Applied between P-Nu, Nv, Nw		300	500	V
V _{CC}	Control supply voltage	Applied between V _{CC} -GND	13.5	15	18	V
V _{BS}	High side bias voltage	Applied between V _{BOOTi} -OUT _i for i = U, V, W	13		18	V
t _{dead}	Blanking time to prevent Arm-short	For each input signal	1.5			μ s
f _{PWM}	PWM input signal	-40°C < T _c < 100°C -40°C < T _j < 125°C			25	kHz
T _C	Case operation temperature				100	°C

Note: For further details refer to AN4043.

6 Package mechanical data

In order to meet environmental requirements, ST offers these devices in different grades of ECOPACK[®] packages, depending on their level of environmental compliance. ECOPACK[®] specifications, grade definitions and product status are available at: www.st.com. ECOPACK[®] is an ST trademark.

Figure 8. NDIP-26L type C mechanical drawing

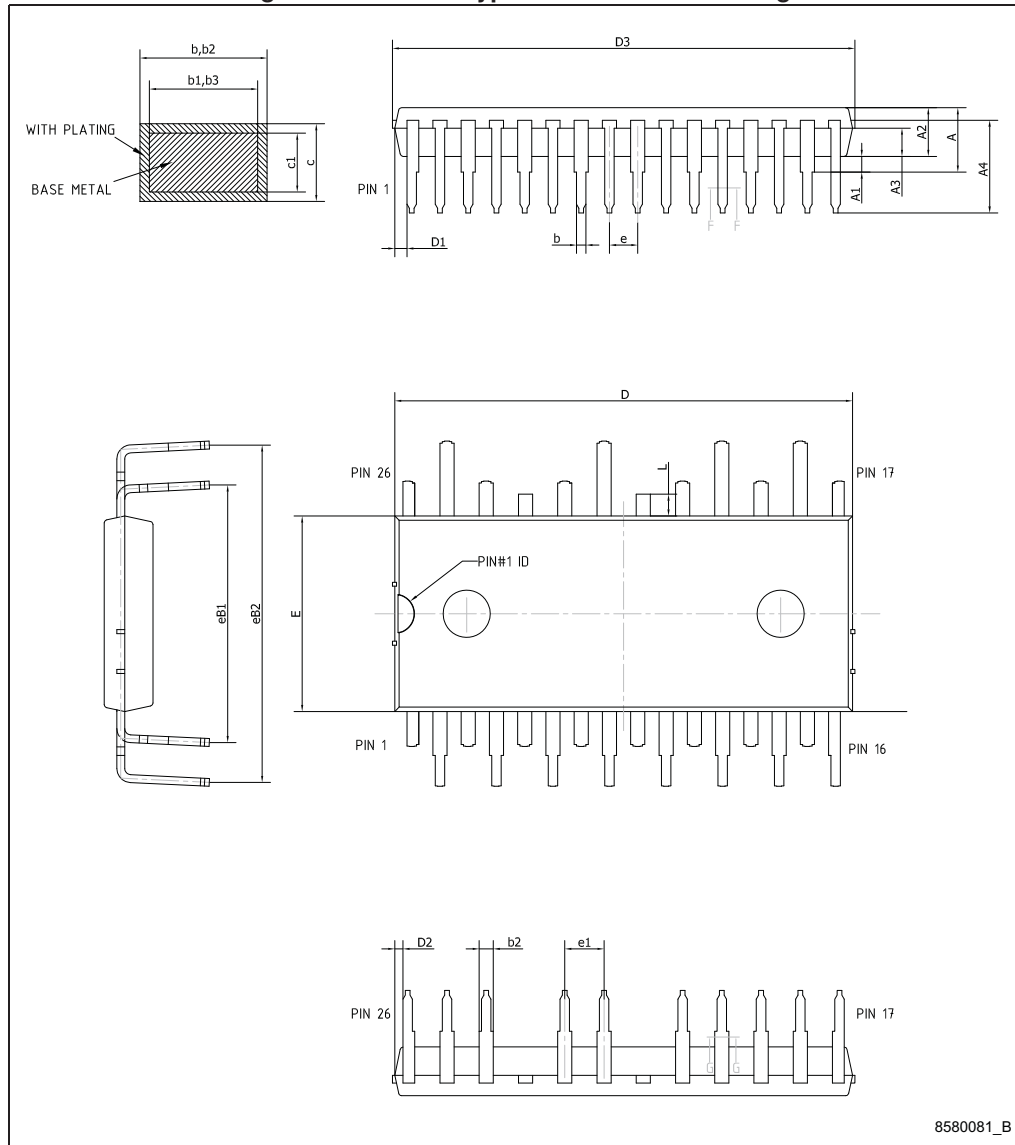
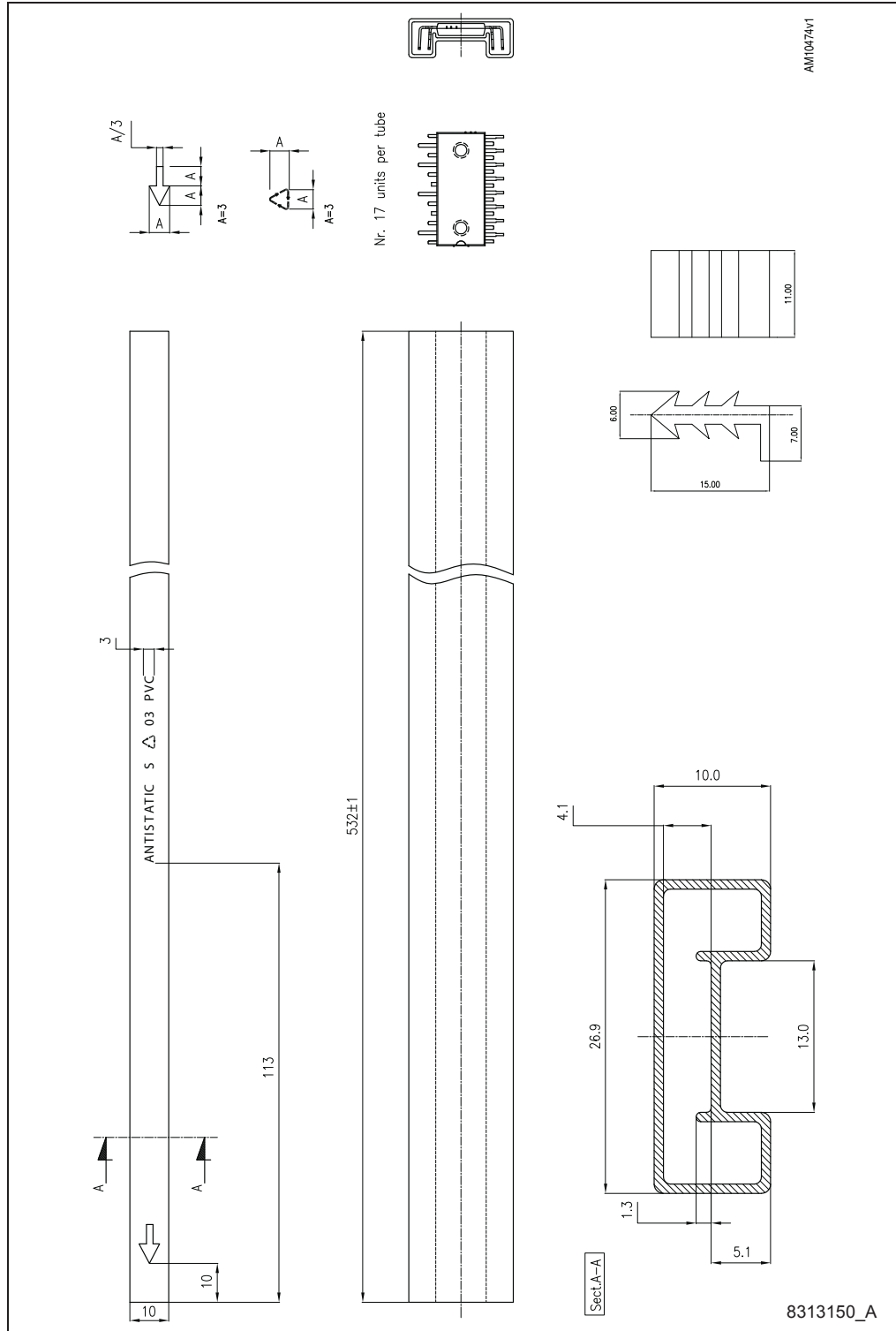

Table 15. NDIP-26L type C mechanical data

Dim.	mm		
	Min.	Typ.	Max.
A			4.40
A1	0.80	1.00	1.20
A2	3.00	3.10	3.20
A3	1.70	1.80	1.90
A4	5.70	5.90	6.10
b	0.53		0.72
b1	0.52	0.60	0.68
b2	0.83		1.02
b3	0.82	0.90	0.98
c	0.46		0.59
c1	0.45	0.50	0.55
D	29.05	29.15	29.25
D1	0.50	0.77	1.00
D2	0.35	0.53	0.70
D3			29.55
E	12.35	12.45	12.55
e	1.70	1.80	1.90
e1	2.40	2.50	2.60
eB1	16.10	16.40	16.70
eB2	21.18	21.48	21.78
L	1.24	1.39	1.54

Figure 9. NDIP-26L tube dimensions (dimensions are in mm.)



Note: Base quantity 17 pcs, bulk quantity 476 pcs.

7 Revision history

Table 16. Document revision history

Date	Revision	Changes
05-Dec-2014	1	Initial release.

IMPORTANT NOTICE – PLEASE READ CAREFULLY

STMicroelectronics NV and its subsidiaries ("ST") reserve the right to make changes, corrections, enhancements, modifications, and improvements to ST products and/or to this document at any time without notice. Purchasers should obtain the latest relevant information on ST products before placing orders. ST products are sold pursuant to ST's terms and conditions of sale in place at the time of order acknowledgement.

Purchasers are solely responsible for the choice, selection, and use of ST products and ST assumes no liability for application assistance or the design of Purchasers' products.

No license, express or implied, to any intellectual property right is granted by ST herein.

Resale of ST products with provisions different from the information set forth herein shall void any warranty granted by ST for such product.

ST and the ST logo are trademarks of ST. All other product or service names are the property of their respective owners.

Information in this document supersedes and replaces information previously supplied in any prior versions of this document.

© 2014 STMicroelectronics – All rights reserved