



Chipsmall Limited consists of a professional team with an average of over 10 year of expertise in the distribution of electronic components. Based in Hongkong, we have already established firm and mutual-benefit business relationships with customers from,Europe,America and south Asia,supplying obsolete and hard-to-find components to meet their specific needs.

With the principle of “Quality Parts,Customers Priority,Honest Operation,and Considerate Service”,our business mainly focus on the distribution of electronic components. Line cards we deal with include Microchip,ALPS,ROHM,Xilinx,Pulse,ON,Everlight and Freescale. Main products comprise IC,Modules,Potentiometer,IC Socket,Relay,Connector.Our parts cover such applications as commercial,industrial, and automotives areas.

We are looking forward to setting up business relationship with you and hope to provide you with the best service and solution. Let us make a better world for our industry!



## Contact us

Tel: +86-755-8981 8866 Fax: +86-755-8427 6832

Email & Skype: info@chipsmall.com Web: www.chipsmall.com

Address: A1208, Overseas Decoration Building, #122 Zhenhua RD., Futian, Shenzhen, China



## SLLIMM™ small low-loss intelligent molded module IPM, 3-phase inverter - 15 A, 600 V short-circuit rugged IGBT

Datasheet - production data

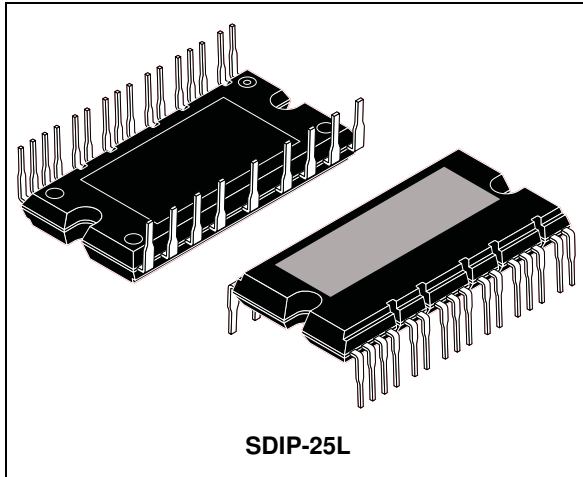

### Applications

- 3-phase inverters for motor drives
- Home appliance, air conditioners

### Description

This intelligent power module provides a compact, high performance AC motor drive in a simple, rugged design. Combining ST proprietary control ICs with the most advanced short-circuit-rugged IGBT system technology, this device is ideal for 3-phase inverters in applications such as motor drives and air conditioners. SLLIMM™ is a trademark of STMicroelectronics.

### Features

- IPM 15 A, 600 V 3-phase IGBT inverter bridge including control ICs for gate driving and free-wheeling diodes
- Short-circuit rugged IGBTs
- 3.3 V, 5 V, 15 V CMOS/TTL inputs comparators with hysteresis and pull-down / pull-up resistors
- Undervoltage lockout
- Internal bootstrap diode
- Interlocking function
- Shutdown function
- 4.7 kΩ NTC for temperature control
- DBC leading to low thermal resistance
- Isolation rating of 2500 V<sub>rms</sub>/min
- UL recognized: UL1557 file E81734

**Table 1. Device summary**

Order code	Marking	Package	Packing
STGIPS15C60T-H	GIPS15C60T-H	SDIP-25L	Tube

# Contents

- 1 Internal block diagram and pin configuration ..... 3**
- 2 Electrical ratings ..... 5**
  - 2.1 Absolute maximum ratings ..... 5
  - 2.2 Thermal data ..... 6
- 3 Electrical characteristics ..... 7**
  - 3.1 Control part ..... 9
    - 3.1.1 NTC thermistor ..... 11
  - 3.2 Waveform definitions ..... 12
- 4 Application information ..... 13**
  - 4.1 Recommendations ..... 14
- 5 Package information ..... 15**
  - 5.1 SDIP-25L package information ..... 15
  - 5.2 Packing information ..... 17
- 6 Revision history ..... 18**

# 1 Internal block diagram and pin configuration

Figure 1. Internal block diagram

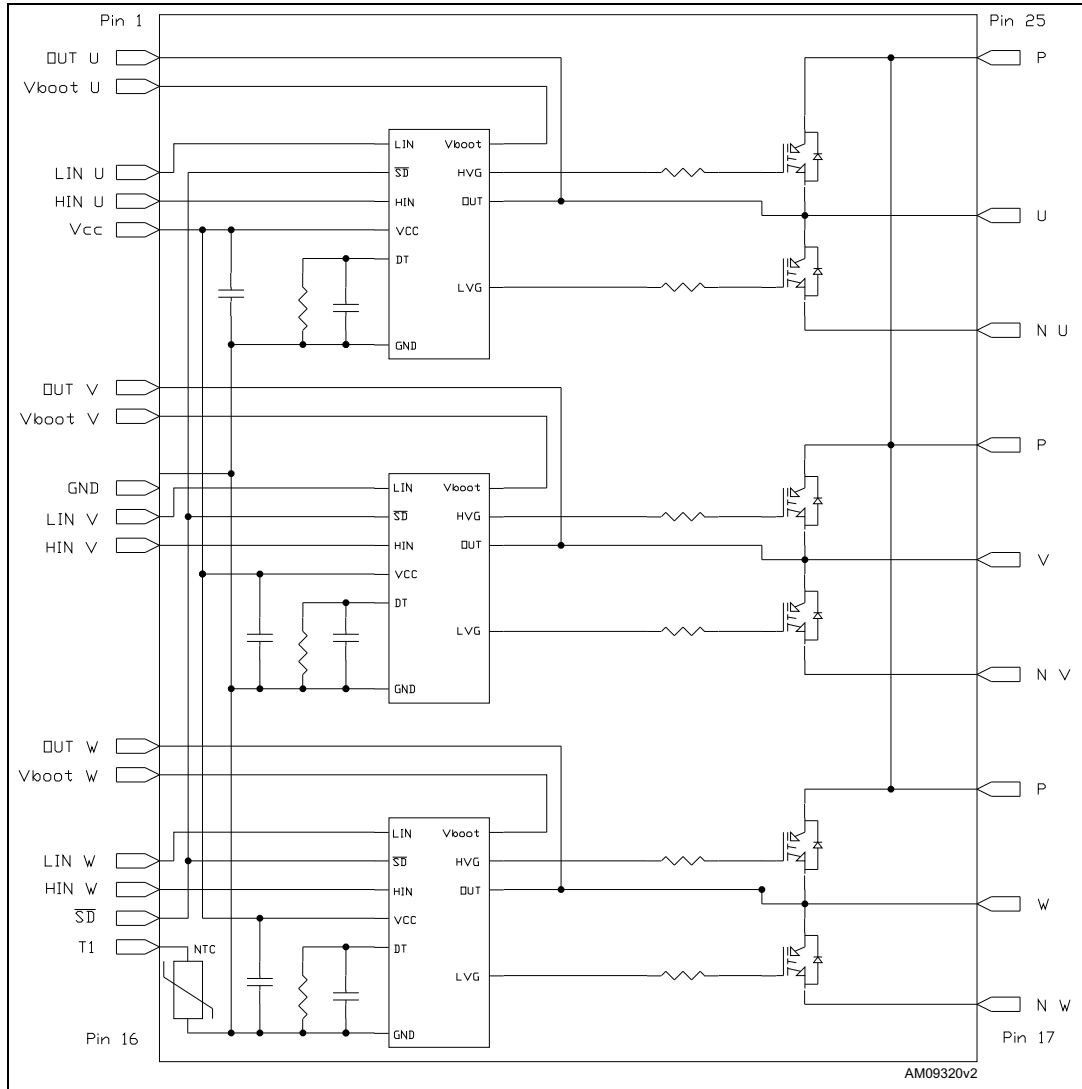

**Table 2. Pin description**

Pin n°	Symbol	Description
1	OUT <sub>U</sub>	High-side reference output for U phase
2	V <sub>bootU</sub>	Bootstrap voltage for U phase
3	LIN <sub>U</sub>	Low-side logic input for U phase
4	HIN <sub>U</sub>	High-side logic input for U phase
5	V <sub>CC</sub>	Low voltage power supply
6	OUT <sub>V</sub>	High-side reference output for V phase
7	V <sub>boot V</sub>	Bootstrap voltage for V phase
8	GND	Ground
9	LIN <sub>V</sub>	Low-side logic input for V phase
10	HIN <sub>V</sub>	High-side logic input for V phase
11	OUT <sub>W</sub>	High-side reference output for W phase
12	V <sub>boot W</sub>	Bootstrap voltage for W phase
13	LIN <sub>W</sub>	Low-side logic input for W phase
14	HIN <sub>W</sub>	High-side logic input for W phase
15	$\overline{SD}$	Shutdown logic input (active low)
16	T1	NTC thermistor terminal
17	N <sub>W</sub>	Negative DC input for W phase
18	W	W phase output
19	P	Positive DC input
20	N <sub>V</sub>	Negative DC input for V phase
21	V	V phase output
22	P	Positive DC input
23	N <sub>U</sub>	Negative DC input for U phase
24	U	U phase output
25	P	Positive DC input

**Figure 2. Pin layout (bottom view)**

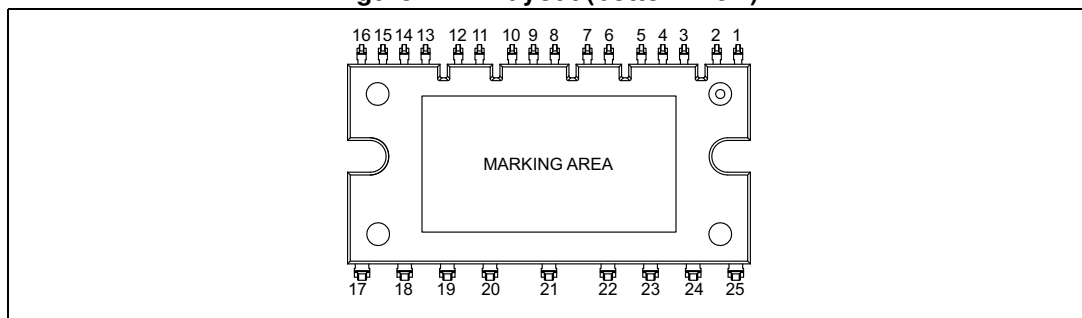

## 2 Electrical ratings

### 2.1 Absolute maximum ratings

**Table 3. Inverter part**

Symbol	Parameter	Value	Unit
$V_{PN}$	Supply voltage applied between P - $N_U$ , $N_V$ , $N_W$	450	V
$V_{PN(surge)}$	Supply voltage (surge) applied between P - $N_U$ , $N_V$ , $N_W$	500	V
$V_{CES}$	Each IGBT collector emitter voltage ( $V_{IN}^{(1)} = 0$ V)	600	V
$\pm I_C$	Each IGBT continuous collector current at $T_C = 25^\circ\text{C}$	15	A
$\pm I_{CP}^{(2)}$	Each IGBT pulsed collector current	30	A
$P_{TOT}$	Each IGBT total dissipation at $T_C = 25^\circ\text{C}$	42	W
$t_{scw}$	Short circuit withstand time, $V_{CE} = 0.5 V_{(BR)CES}$ $T_J = 125^\circ\text{C}$ , $V_{CC} = V_{boot} = 15$ V, $V_{IN}^{(1)} = 0 - 5$ V	5	$\mu\text{s}$

1. Applied between  $HIN_i$ ,  $LIN_i$  and GND for  $i = U, V, W$
2. Pulse width limited by max junction temperature

**Table 4. Control part**

Symbol	Parameter	Value	Unit
$V_{OUT}$	Output voltage applied between $OUT_U$ , $OUT_V$ , $OUT_W$ - GND	$V_{boot} - 21$ to $V_{boot} + 0.3$	V
$V_{CC}$	Low voltage power supply	- 0.3 to +21	V
$V_{boot}$	Bootstrap voltage applied between $V_{boot\ i} - OUT_i$ for $i = U, V, W$	- 0.3 to 620	V
$V_{IN}$	Logic input voltage applied between $HIN$ , $LIN$ and GND	- 0.3 to 15	V
$V_{SD}$	Open drain voltage	- 0.3 to 15	V
$dV_{OUT}/dt$	Allowed output slew rate	50	V/ns

**Table 5. Total system**

Symbol	Parameter	Value	Unit
$V_{ISO}$	Isolation withstand voltage applied between each pin and heatsink plate (AC voltage, $t = 60$ s)	2500	V
$T_j$	Power chips operating junction temperature	- 40 to 150	$^\circ\text{C}$
$T_C$	Module case operation temperature	- 40 to 125	$^\circ\text{C}$

## 2.2 Thermal data

**Table 6. Thermal data**

Symbol	Parameter	Value	Unit
$R_{thJC}$	Thermal resistance junction-case single IGBT	3	°C/W
	Thermal resistance junction-case single diode	5.5	°C/W

### 3 Electrical characteristics

T<sub>J</sub> = 25 °C unless otherwise specified.

**Table 7. Inverter part**

Symbol	Parameter	Test conditions	Value			Unit
			Min.	Typ.	Max.	
V <sub>CE(sat)</sub>	Collector-emitter saturation voltage	V <sub>CC</sub> = V <sub>boot</sub> = 15 V, V <sub>IN</sub> <sup>(1)</sup> = 0 - 5 V, I <sub>C</sub> = 15 A	-	1.6	2	V
		V <sub>CC</sub> = V <sub>boot</sub> = 15 V, V <sub>IN</sub> <sup>(1)</sup> = 0 - 5 V, I <sub>C</sub> = 15 A, T <sub>J</sub> = 125 °C	-	1.7		
I <sub>CES</sub>	Collector-cut off current (V <sub>IN</sub> <sup>(1)</sup> = 0 "logic state")	V <sub>CE</sub> = 550 V, V <sub>CC</sub> = V <sub>Boot</sub> = 15 V	-		100	μA
V <sub>F</sub>	Diode forward voltage	V <sub>IN</sub> <sup>(1)</sup> = 0 "logic state", I <sub>C</sub> = 15 A	-		2.3	V
<b>Inductive load switching time and energy</b>						
t <sub>on</sub>	Turn-on time	V <sub>PN</sub> = 300 V, V <sub>CC</sub> = V <sub>boot</sub> = 15 V, V <sub>IN</sub> <sup>(1)</sup> = 0 - 5 V, I <sub>C</sub> = 15 A (see <a href="#">Figure 3</a> )	-	330	-	ns
t <sub>c(on)</sub>	Crossover time (on)		-	150	-	
t <sub>off</sub>	Turn-off time		-	925	-	
t <sub>c(off)</sub>	Crossover time (off)		-	135	-	
t <sub>rr</sub>	Reverse recovery time		-	190	-	μJ
E <sub>on</sub>	Turn-on switching losses		-	385	-	
E <sub>off</sub>	Turn-off switching losses		-	294	-	

1. Applied between HIN<sub>i</sub>, LIN<sub>i</sub> and GND for i = U, V, W.

*Note:* t<sub>ON</sub> and t<sub>OFF</sub> include the propagation delay time of the internal drive. t<sub>C(ON)</sub> and t<sub>C(OFF)</sub> are the switching time of IGBT itself under the internally given gate driving condition.



Figure 3. Switching time test circuit

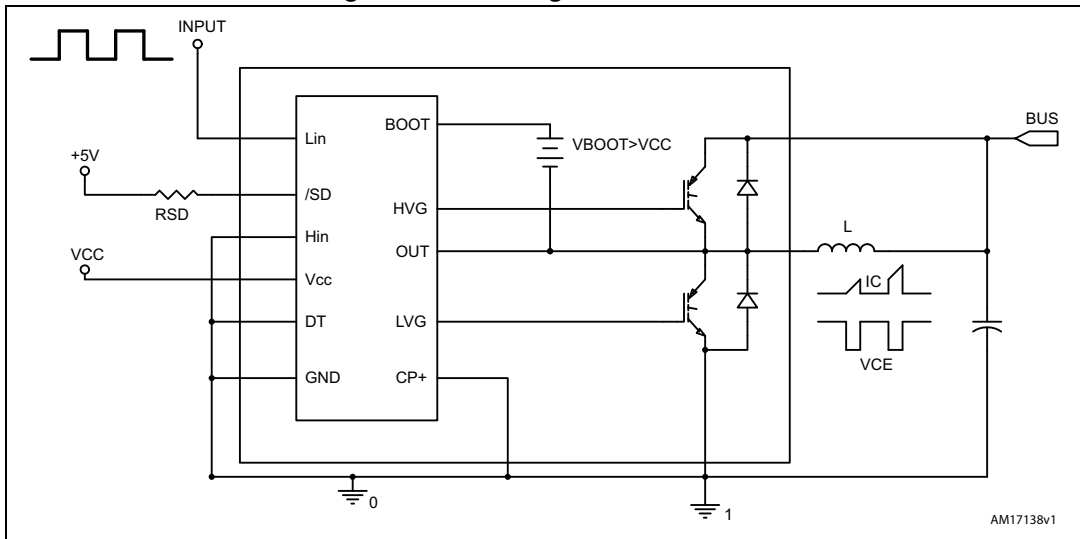
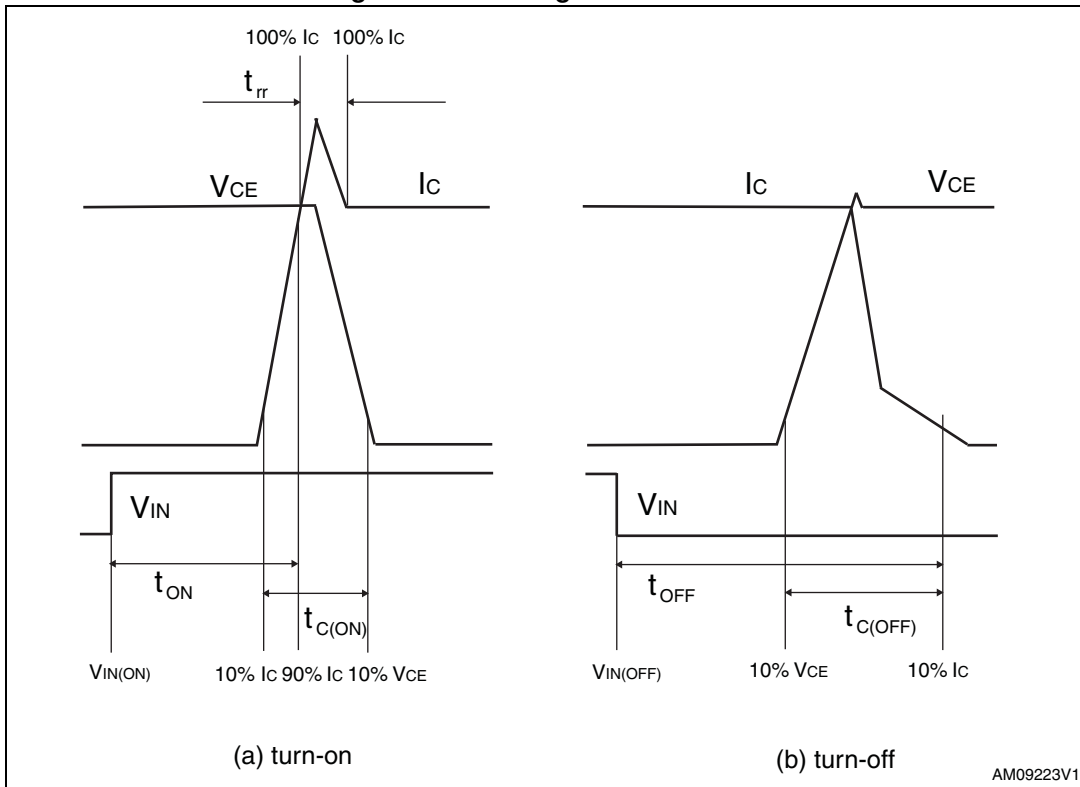

Figure 4. Switching time definition



Note: Figure 4 "Switching time definition" refers to HIN, LIN inputs (active high).

### 3.1 Control part

**Table 8. Low voltage power supply ( $V_{CC} = 15\text{ V}$  unless otherwise specified)**

Symbol	Parameter	Test conditions	Min.	Typ.	Max.	Unit
$V_{CC\_hys}$	$V_{CC}$ UV hysteresis		1.2	1.5	1.8	V
$V_{CC\_thON}$	$V_{CC}$ UV turn ON threshold		11.5	12	12.5	V
$V_{CC\_thOFF}$	$V_{CC}$ UV turn OFF threshold		10	10.5	11	V
$I_{qccu}$	Undervoltage quiescent supply current	$V_{CC} = 10\text{ V}$ $\overline{SD} = 5\text{ V}; LIN = HIN = 0$			450	$\mu\text{A}$
$I_{qcc}$	Quiescent current	$V_{CC} = 15\text{ V}$ $\overline{SD} = 5\text{ V}; LIN = HIN = 0$			3.5	mA

**Table 9. Bootstrapped voltage ( $V_{CC} = 15\text{ V}$  unless otherwise specified)**

Symbol	Parameter	Test conditions	Min.	Typ.	Max.	Unit
$V_{BS\_hys}$	$V_{BS}$ UV hysteresis		1.2	1.5	1.8	V
$V_{BS\_thON}$	$V_{BS}$ UV turn ON threshold		11.1	11.5	12.1	V
$V_{BS\_thOFF}$	$V_{BS}$ UV turn OFF threshold		9.8	10	10.6	V
$I_{QBSU}$	Undervoltage $V_{BS}$ quiescent current	$V_{BS} < 9\text{ V}$ $\overline{SD} = 5\text{ V}; LIN = 0; HIN = 5\text{ V}$		70	110	$\mu\text{A}$
$I_{QBS}$	$V_{BS}$ quiescent current	$V_{BS} = 15\text{ V}$ $\overline{SD} = 5\text{ V}; LIN = 0; HIN = 5\text{ V}$		200	300	$\mu\text{A}$
$R_{DS(on)}$	Bootstrap driver on resistance	$LIN = 5\text{ V}; HIN = 0\text{ V}$		120		$\Omega$

**Table 10. Logic inputs ( $V_{CC} = 15\text{ V}$  unless otherwise specified)**

Symbol	Parameter	Test conditions	Min.	Typ.	Max.	Unit
$V_{il}$	Low level logic threshold voltage		0.8		1.1	V
$V_{ih}$	High level logic threshold voltage		1.9		2.25	V
$I_{HINh}$	HIN logic "1" input bias current	$HIN = 15\text{ V}$	20	40	100	$\mu\text{A}$
$I_{HINI}$	HIN logic "0" input bias current	$HIN = 0\text{ V}$			1	$\mu\text{A}$
$I_{LINh}$	LIN logic "1" input bias current	$LIN = 15\text{ V}$	20	40	100	$\mu\text{A}$
$I_{LINI}$	LIN logic "0" input bias current	$LIN = 0\text{ V}$			1	$\mu\text{A}$
$I_{SDh}$	$\overline{SD}$ logic "0" input bias current	$\overline{SD} = 15\text{ V}$	30	120	300	$\mu\text{A}$
$I_{SDI}$	$\overline{SD}$ logic "1" input bias current	$\overline{SD} = 0\text{ V}$			3	$\mu\text{A}$
Dt	Dead time	see <a href="#">Figure 7</a> and <a href="#">Table 14</a>		1.2		$\mu\text{s}$

**Table 11. Shutdown characteristics ( $V_{CC} = 15\text{ V}$  unless otherwise specified)**

Symbol	Parameter	Test conditions	Min.	Typ.	Max.	Unit
$t_{sd}$	Shut down to high / low side driver propagation delay	$V_{OUT} = 0, V_{boot} = V_{CC}, V_{IN} = 0$ to 3.3 V	50	125	200	ns

**Table 12. Truth table**

Condition	Logic input ( $V_I$ )			Output	
	$\overline{SD/OD}$	LIN	HIN	LVG	HVG
Shutdown enable half-bridge tri-state	L	X	X	L	L
Interlocking half-bridge tri-state	H	H	H	L	L
0 "logic state" half-bridge tri-state	H	L	L	L	L
1 "logic state" low side direct driving	H	H	L	H	L
1 "logic state" high side direct driving	H	L	H	L	H

Note: X: don't care

3.1.1 NTC thermistor

Table 13. NTC thermistor

Symbol	Parameter	Test conditions	Min.	Typ.	Max.	Unit.
R <sub>25</sub>	Resistance	T = 25°C		4.7		kΩ
R <sub>125</sub>	Resistance	T = 125°C		160		Ω
B	B-constant	T = 25°C to 85°C		3950		K
T	Operating temperature		-40		150	°C

Equation 1: resistance variation vs. temperature

$$R(T) = R_{25} \cdot e^{B \left( \frac{1}{T} - \frac{1}{298} \right)}$$

Where T are temperatures in Kelvins

Figure 5. NTC resistance vs. temperature

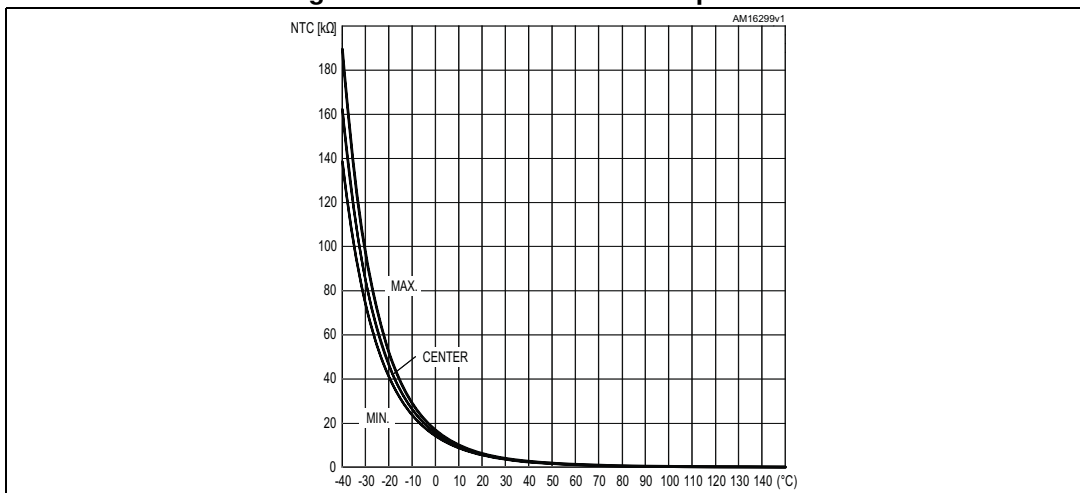
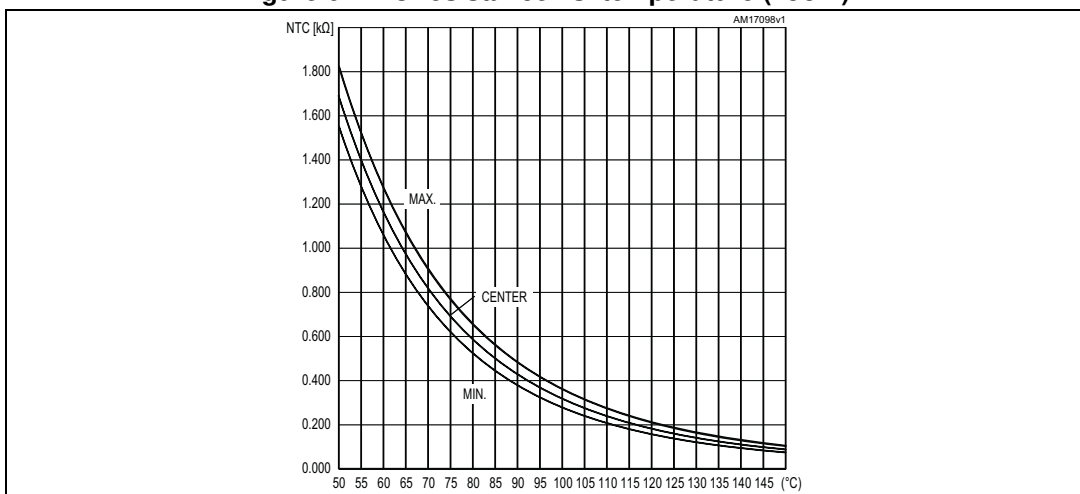
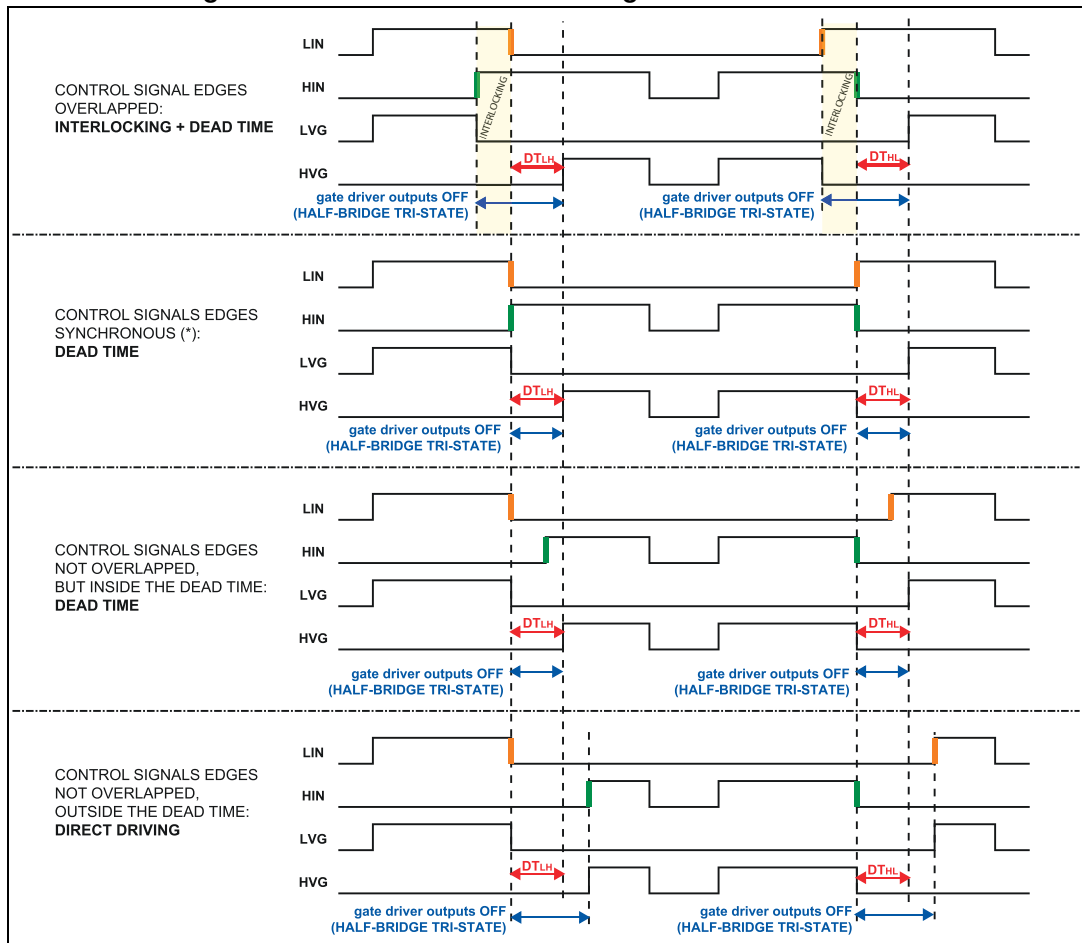

Figure 6. NTC resistance vs. temperature (zoom)



### 3.2 Waveform definitions

Figure 7. Dead time and interlocking waveforms definition



## 4 Application information

Figure 8. Typical application circuit

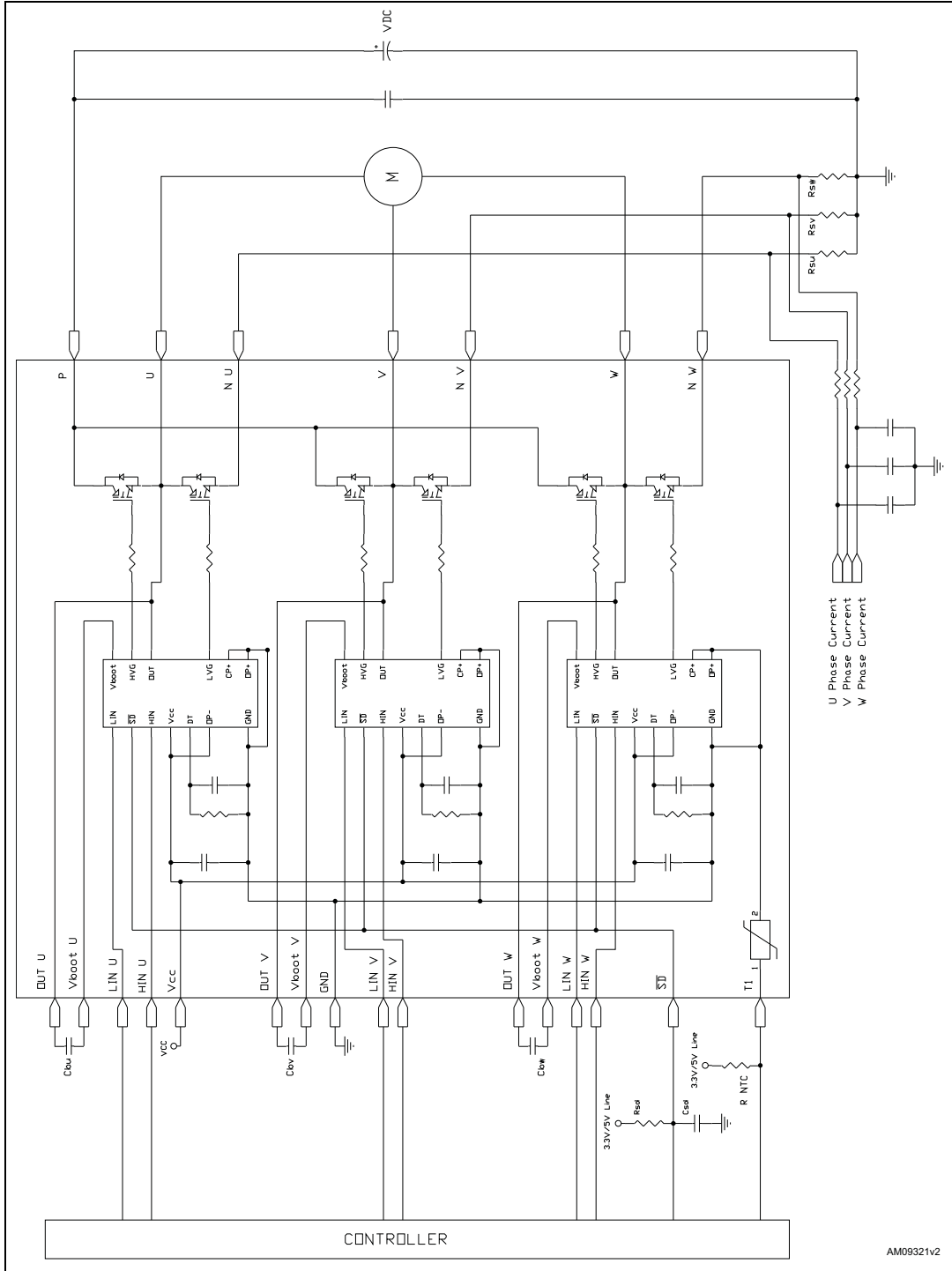

### 4.1 Recommendations

- Input signals HIN, LIN are active high logic. A 375 kΩ (typ.) pull down resistor is built-in for each input. If an external RC filter is used, for noise immunity, pay attention to the variation of the input signal level.
- To prevent the input signals oscillation, the wiring of each input should be as short as possible.
- By integrating an application specific type HVIC inside the module, direct coupling to MCU terminals without any opto-coupler is possible.
- Each capacitor should be located as nearby the pins of IPM as possible.
- Low inductance shunt resistors should be used for phase leg current sensing.
- Electrolytic bus capacitors should be mounted as close to the module bus terminals as possible. Additional high frequency ceramic capacitor mounted close to the module pins will further improve performance.
- The  $\overline{SD}$  signal should be pulled up to 5 V / 3.3 V with an external resistor.

**Table 14. Recommended operating conditions**

Symbol	Parameter	Conditions	Value			Unit
			Min.	Typ.	Max.	
V <sub>PN</sub>	Supply Voltage	Applied between P-Nu,Nv,Nw		300	400	V
V <sub>CC</sub>	Control supply voltage	Applied between V <sub>CC</sub> -GND	13.5	15	18	V
V <sub>BS</sub>	High side bias voltage	Applied between V <sub>BOOTi</sub> -OUT <sub>i</sub> for i=U,V,W	13		18	V
t <sub>dead</sub>	Blanking time to prevent Arm-short	For each input signal	1.5			μs
f <sub>PWM</sub>	PWM input signal	-40°C < T <sub>c</sub> < 100°C -40°C < T <sub>j</sub> < 125°C			20	kHz
T <sub>C</sub>	Case operation temperature				100	°C

Note: For further details refer to AN3338.



## 5 Package information

In order to meet environmental requirements, ST offers these devices in different grades of ECOPACK<sup>®</sup> packages, depending on their level of environmental compliance. ECOPACK<sup>®</sup> specifications, grade definitions and product status are available at: [www.st.com](http://www.st.com). ECOPACK<sup>®</sup> is an ST trademark.

Please refer to dedicated technical note TN0107 for mounting instructions.

### 5.1 SDIP-25L package information

Figure 9. SDIP-25L package outline

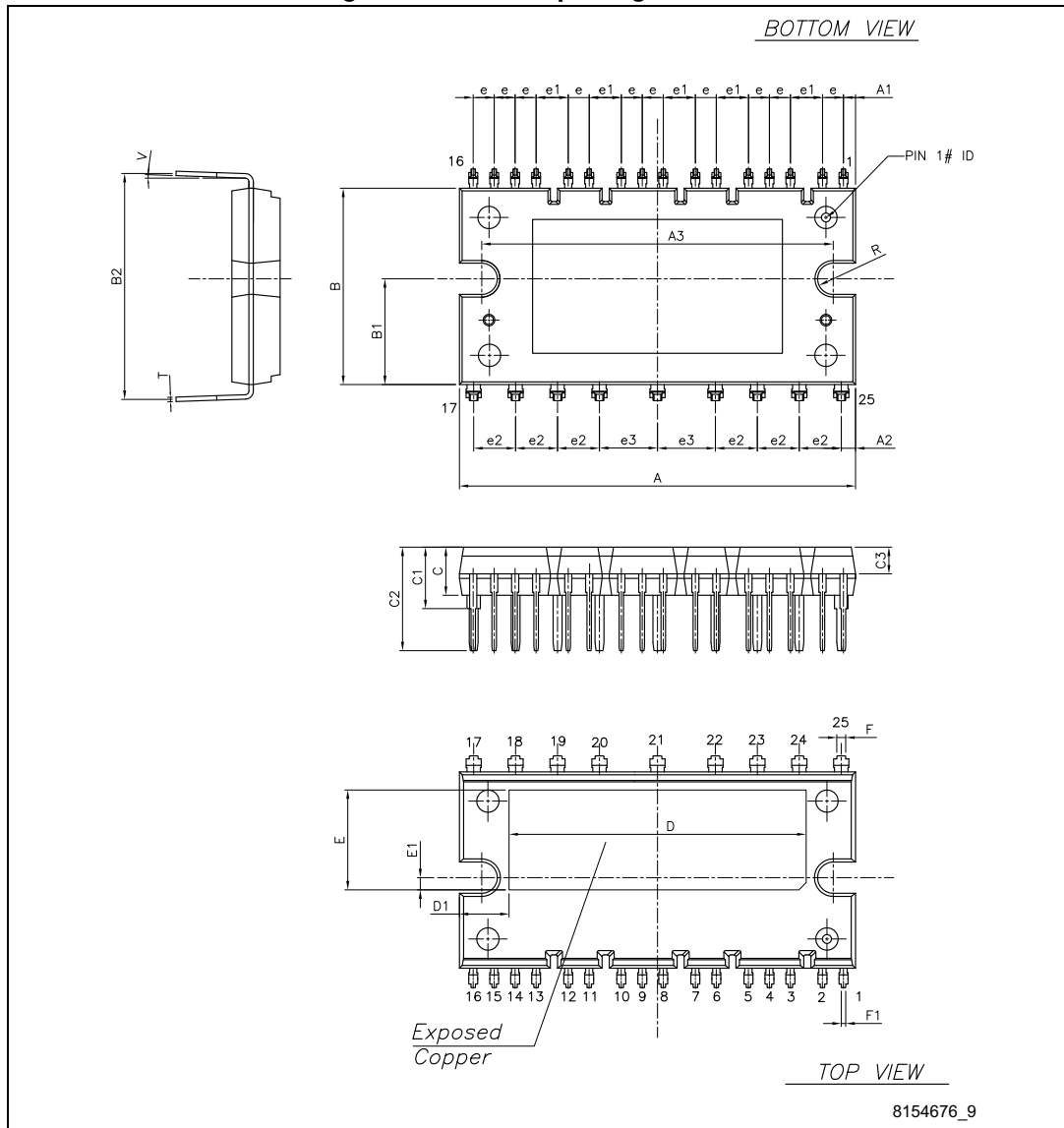

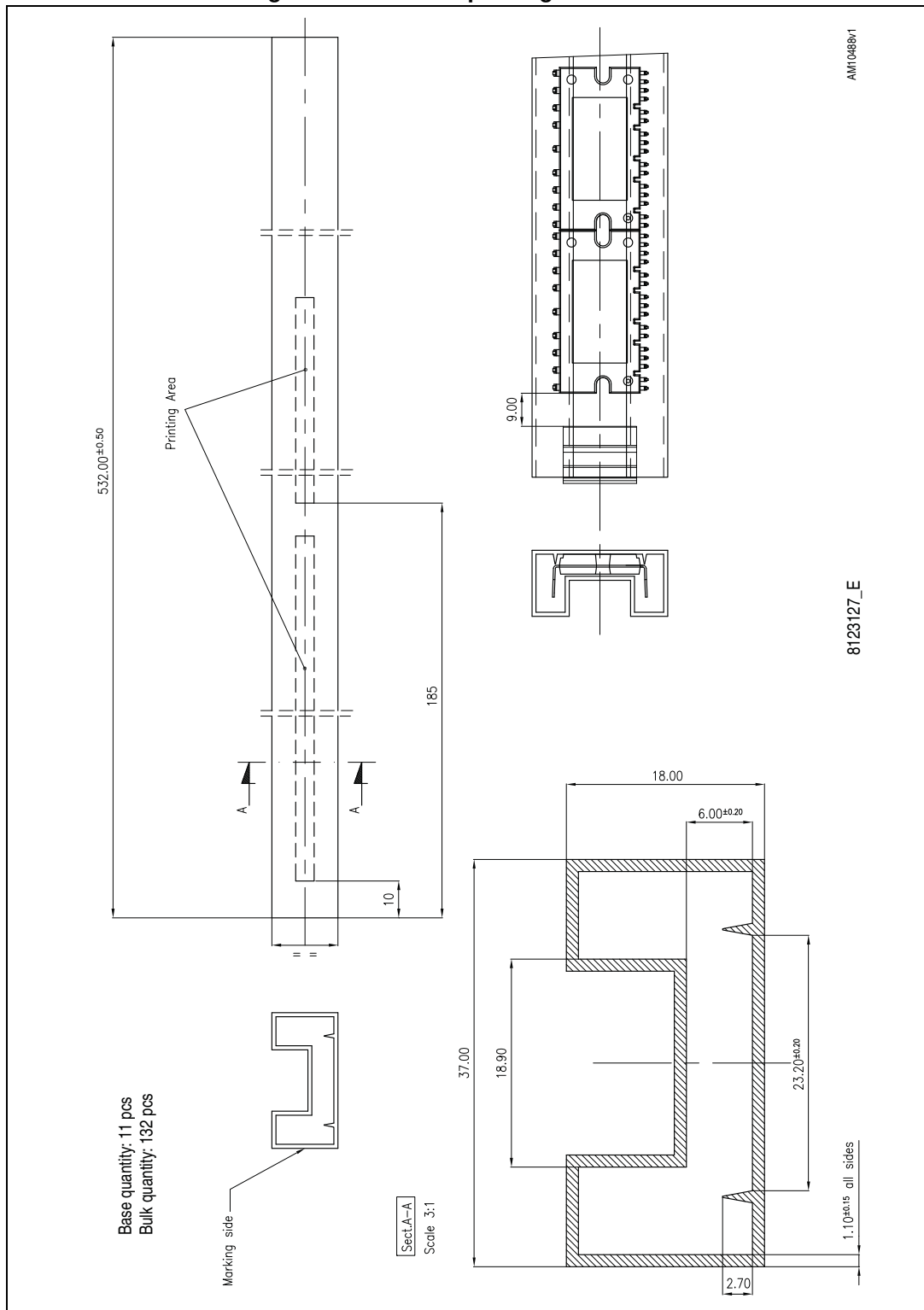

Table 15. SDIP-25L mechanical data

Dim.	mm		
	Min.	Typ.	Max.
A	43.90	44.40	44.90
A1	1.15	1.35	1.55
A2	1.40	1.60	1.80
A3	38.90	39.40	39.90
B	21.50	22.00	22.50
B1	11.25	11.85	12.45
B2	24.83	25.23	25.63
C	5.00	5.40	6.00
C1	6.50	7.00	7.50
C2	11.20	11.70	12.20
C3	2.90	3.00	3.10
e	2.15	2.35	2.55
e1	3.40	3.60	3.80
e2	4.50	4.70	4.90
e3	6.30	6.50	6.70
D		33.30	
D1		5.55	
E		11.20	
E1		1.40	
F	0.85	1.00	1.15
F1	0.35	0.50	0.65
R	1.55	1.75	1.95
T	0.45	0.55	0.65
V	0°		6°

## 5.2 Packing information

Figure 10. SDIP-25L packing information



## 6 Revision history

**Table 16. Document revision history**

Date	Revision	Changes
19-May-2014	1	Initial release.
09-Apr-2015	2	Text edits and formatting changes throughout document Updated <a href="#">Figure 2: Pin layout (bottom view)</a> Updated <a href="#">Section 5: Package information</a>

**IMPORTANT NOTICE – PLEASE READ CAREFULLY**

STMicroelectronics NV and its subsidiaries (“ST”) reserve the right to make changes, corrections, enhancements, modifications, and improvements to ST products and/or to this document at any time without notice. Purchasers should obtain the latest relevant information on ST products before placing orders. ST products are sold pursuant to ST’s terms and conditions of sale in place at the time of order acknowledgement.

Purchasers are solely responsible for the choice, selection, and use of ST products and ST assumes no liability for application assistance or the design of Purchasers’ products.

No license, express or implied, to any intellectual property right is granted by ST herein.

Resale of ST products with provisions different from the information set forth herein shall void any warranty granted by ST for such product.

ST and the ST logo are trademarks of ST. All other product or service names are the property of their respective owners.

Information in this document supersedes and replaces information previously supplied in any prior versions of this document.

© 2015 STMicroelectronics – All rights reserved

