



Chipsmall Limited consists of a professional team with an average of over 10 year of expertise in the distribution of electronic components. Based in Hongkong, we have already established firm and mutual-benefit business relationships with customers from,Europe,America and south Asia,supplying obsolete and hard-to-find components to meet their specific needs.

With the principle of "Quality Parts,Customers Priority,Honest Operation,and Considerate Service",our business mainly focus on the distribution of electronic components. Line cards we deal with include Microchip,ALPS,ROHM,Xilinx,Pulse,ON,Everlight and Freescale. Main products comprise IC,Modules,Potentiometer,IC Socket,Relay,Connector.Our parts cover such applications as commercial,industrial, and automotives areas.

We are looking forward to setting up business relationship with you and hope to provide you with the best service and solution. Let us make a better world for our industry!



Contact us

Tel: +86-755-8981 8866 Fax: +86-755-8427 6832

Email & Skype: info@chipsmall.com Web: www.chipsmall.com

Address: A1208, Overseas Decoration Building, #122 Zhenhua RD., Futian, Shenzhen, China





STGIPS20K60

IGBT intelligent power module (IPM)
18 A, 600 V, DBC isolated SDIP-25L molded

Features

- 18 A, 600 V 3-phase IGBT inverter bridge including control ICs for gate driving and free-wheeling diodes
- 3.3 V, 5 V, 15 V CMOS/TTL inputs comparators with hysteresis and pull down / pull up resistors
- Internal bootstrap diode
- Interlocking function
- $V_{CE(sat)}$ negative temperature coefficient
- Short-circuit rugged IGBTs
- Undervoltage lockout
- Smart shutdown function
- Comparator for fault protection against over temperature and overcurrent
- DBC fully isolated package
- Isolation rating of 2500 Vrms/min

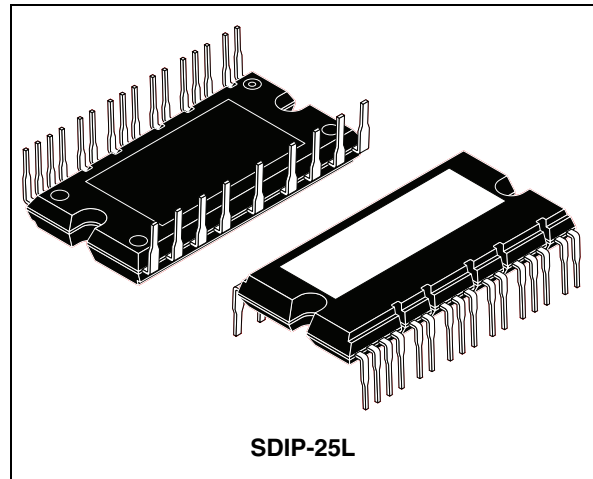

technology. Please refer to dedicated technical note TN0107 for mounting instructions.

Applications

- 3-phase inverters for motor drives
- Home appliances, such as washing machines, refrigerators, air conditioners

Description

The STGIPS20K60 intelligent power module provides a compact, high performance AC motor drive for a simple and rugged design. It mainly targets low power inverters for applications such as home appliances and air conditioners. It combines ST proprietary control ICs with the most advanced short circuit rugged IGBT system

Table 1. Device summary

Order code	Marking	Package	Packaging
STGIPS20K60	GIPS20K60	SDIP-25L	Tube

Contents

1	Internal block diagram and pin configuration	3
2	Electrical ratings	5
2.1	Absolute maximum ratings	5
2.2	Thermal data	6
3	Electrical characteristics	7
3.1	Control part	9
3.2	Waveforms definitions	12
4	Smart shutdown function	13
5	Applications information	14
5.1	Recommendations	15
6	Package mechanical data	16
7	Revision history	18

1 Internal block diagram and pin configuration

Figure 1. Internal block diagram

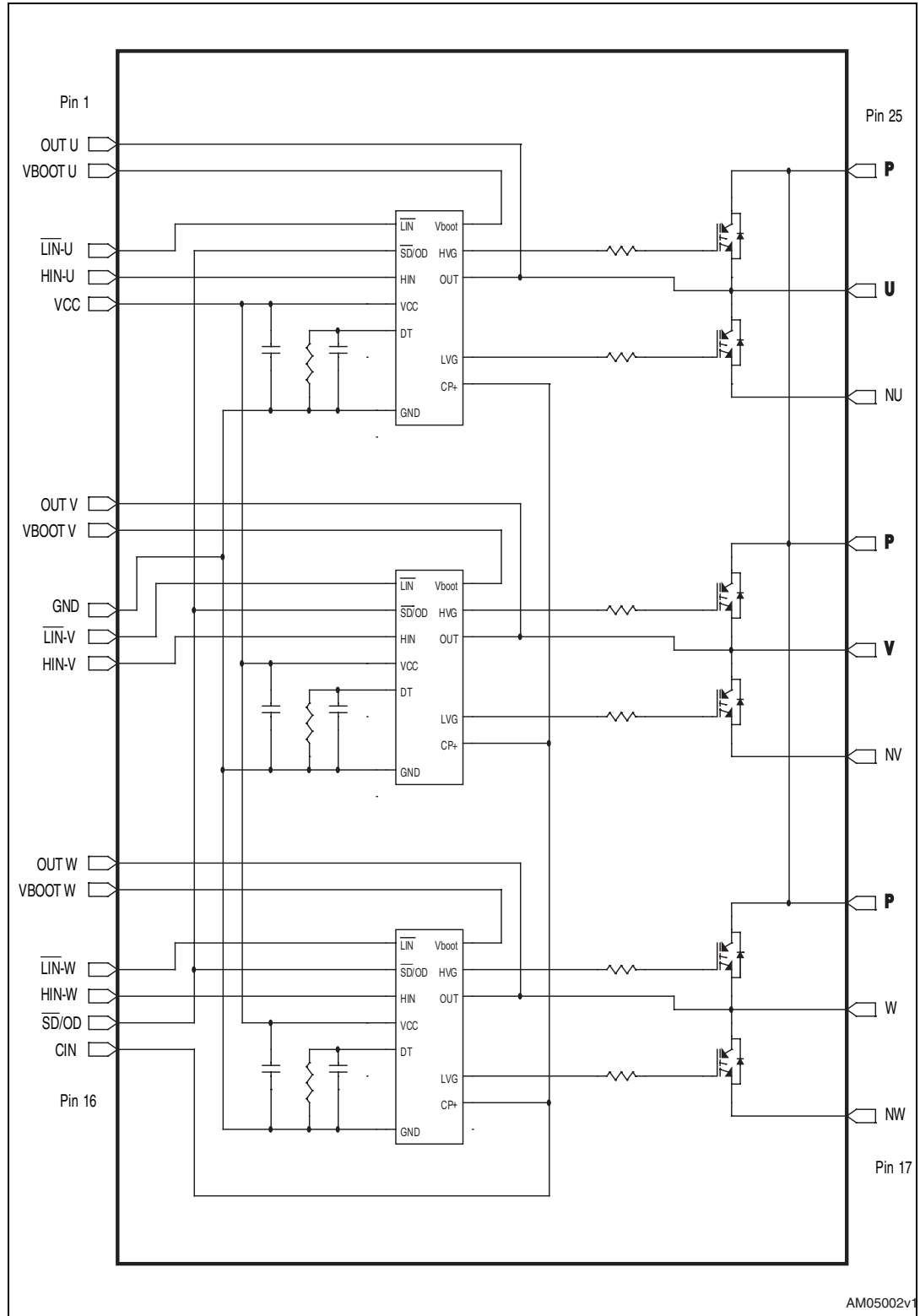
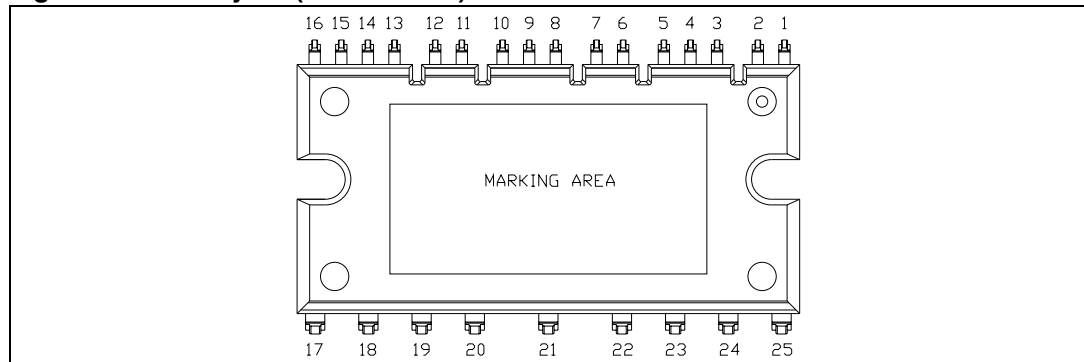

Table 2. Pin description

Pin n°	Symbol	Description
1	OUT _U	High-side reference output for U phase
2	V _{bootU}	Bootstrap voltage for U phase
3	$\overline{\text{LIN}}_{\text{U}}$	Low-side logic input for U phase
4	HIN _U	High-side logic input for U phase
5	V _{CC}	Low voltage power supply
6	OUT _V	High-side reference output for V phase
7	V _{boot V}	Bootstrap voltage for V phase
8	GND	Ground
9	$\overline{\text{LIN}}_{\text{V}}$	Low-side logic input for V phase
10	HIN _V	High-side logic input for V phase
11	OUT _W	High-side reference output for W phase
12	V _{boot W}	Bootstrap voltage for W phase
13	$\overline{\text{LIN}}_{\text{W}}$	Low-side logic input for W phase
14	HIN _W	High-side logic input for W phase
15	$\overline{\text{SD}} / \text{OD}$	Shutdown logic input (active low) / open-drain (comparator output)
16	CIN	Comparator input
17	N _W	Negative DC input for W phase
18	W	W phase output
19	P	Positive DC input
20	N _V	Negative DC input for V phase
21	V	V phase output
22	P	Positive DC input
23	N _U	Negative DC input for U phase
24	U	U phase output
25	P	Positive DC input

Figure 2. Pin layout (bottom view)



2 Electrical ratings

2.1 Absolute maximum ratings

Table 3. Inverter part

Symbol	Parameter	Value	Unit
V_{PN}	Supply voltage applied between P - N _U , N _V , N _W	450	V
$V_{PN(surge)}$	Supply voltage (surge) applied between P - N _U , N _V , N _W	500	V
V_{CES}	Collector emitter voltage ($V_{IN}^{(1)} = 0$)	600	V
$\pm I_C^{(2)}$	Each IGBT continuous collector current at $T_C = 25^\circ\text{C}$	18	A
$\pm I_{CP}^{(3)}$	Each IGBT pulsed collector current	40	A
P_{TOT}	Each IGBT total dissipation at $T_C = 25^\circ\text{C}$	52	W
t_{scw}	Short circuit withstand time, $V_{CE} = 0.5 V_{(BR)CES}$ $T_J = 125^\circ\text{C}$, $V_{CC} = V_{boot} = 15\text{ V}$, $V_{IN}^{(1)} = 0 \div 5\text{ V}$	5	μs

1. Applied between HIN_i, $\overline{\text{LIN}}_i$ and GND for $i = U, V, W$
2. Calculated according to the iterative formula:

$$I_C(T_C) = \frac{T_{j(max)} - T_C}{R_{thj-c} \times V_{CE(sat)(max)}(T_{j(max)}, I_C(T_C))}$$

3. Pulse width limited by max junction temperature

Table 4. Control part

Symbol	Parameter	Value	Unit
V_{OUT}	Output voltage applied between OUT _U , OUT _V , OUT _W - GND	$V_{boot} - 21$ to $V_{boot} + 0.3$	V
V_{CC}	Low voltage power supply	-0.3 to +21	V
V_{CIN}	Comparator input voltage	-0.3 to $V_{CC} + 0.3$	V
V_{boot}	Bootstrap voltage applied between $V_{boot\ i} - OUT_i$ for $i = U, V, W$	-0.3 to 620	V
V_{IN}	Logic input voltage applied between HIN, $\overline{\text{LIN}}$ and GND	-0.3 to 15	V
$V_{SD/OD}$	Open drain voltage	-0.3 to 15	V
dV_{OUT}/dt	Allowed output slew rate	50	V/ns

Table 5. Total system

Symbol	Parameter	Value	Unit
V_{ISO}	Isolation withstand voltage applied between each pin and heatsink plate (AC voltage, $t = 60$ sec.)	2500	V
$T_j^{(1)}$	Operating junction temperature	-40 to 150	°C
T_C	Module case operation temperature	-40 to 125	°C

1. The maximum junction temperature rating of the power chips integrated within the SDIP module is 150°C (@ $T_C \leq 100^\circ\text{C}$). To ensure safe operation of the SDIP module, the average junction temperature should be limited to $T_{j(\text{avg})} \leq 125^\circ\text{C}$ (@ $T_C \leq 100^\circ\text{C}$)

2.2 Thermal data

Table 6. Thermal data

Symbol	Parameter	Value	Unit
R_{thJC}	Thermal resistance junction-case single IGBT	2.4	°C/W
	Thermal resistance junction-case single diode	5	°C/W

3 Electrical characteristics

($T_J = 25\text{ °C}$ unless otherwise specified)

Table 7. Inverter part

Symbol	Parameter	Test conditions	Value			Unit
			Min.	Typ.	Max.	
$V_{CE(sat)}$	Collector-emitter saturation voltage	$V_{CC} = V_{boot} = 15\text{ V}$, $V_{IN}^{(1)} = 0 \div 5\text{ V}$, $I_C = 12\text{ A}$	-	2.2	2.75	V
		$V_{CC} = V_{boot} = 15\text{ V}$, $V_{IN}^{(1)} = 0 \div 5\text{ V}$, $I_C = 12\text{ A}$, $T_J = 125\text{ °C}$	-	1.8		
I_{CES}	Collector-cut off current ($V_{IN}^{(1)} = 0$ "logic state")	$V_{CE} = 600\text{ V}$, $V_{CC} = V_{Boot} = 15\text{ V}$	-		100	μA
V_F	Diode forward voltage	$V_{IN}^{(1)} = 0$ "logic state", $I_C = 12\text{ A}$	-		3.8	V
Inductive load switching time and energy						
t_{on}	Turn-on time	$V_{PN} = 300\text{ V}$, $V_{CC} = V_{boot} = 15\text{ V}$, $V_{IN}^{(1)} = 0 \div 5\text{ V}$, $I_C = 12\text{ A}$ (see Figure 3)	-	300	-	ns
$t_{c(on)}$	Crossover time (on)		-	150	-	
t_{off}	Turn-off time		-	730	-	
$t_{c(off)}$	Crossover time (off)		-	170	-	
t_{rr}	Reverse recovery time		-	60	-	μJ
E_{on}	Turn-on switching losses		-	290	-	
E_{off}	Turn-off switching losses		-	250	-	

1. Applied between HIN_i , \overline{LIN}_i and GND for $i = U, V, W$. (\overline{LIN} inputs are active-low).

Note: t_{ON} and t_{OFF} include the propagation delay time of the internal drive. $t_{C(ON)}$ and $t_{C(OFF)}$ are the switching time of IGBT itself under the internally given gate driving condition.

Figure 3. Switching time test circuit

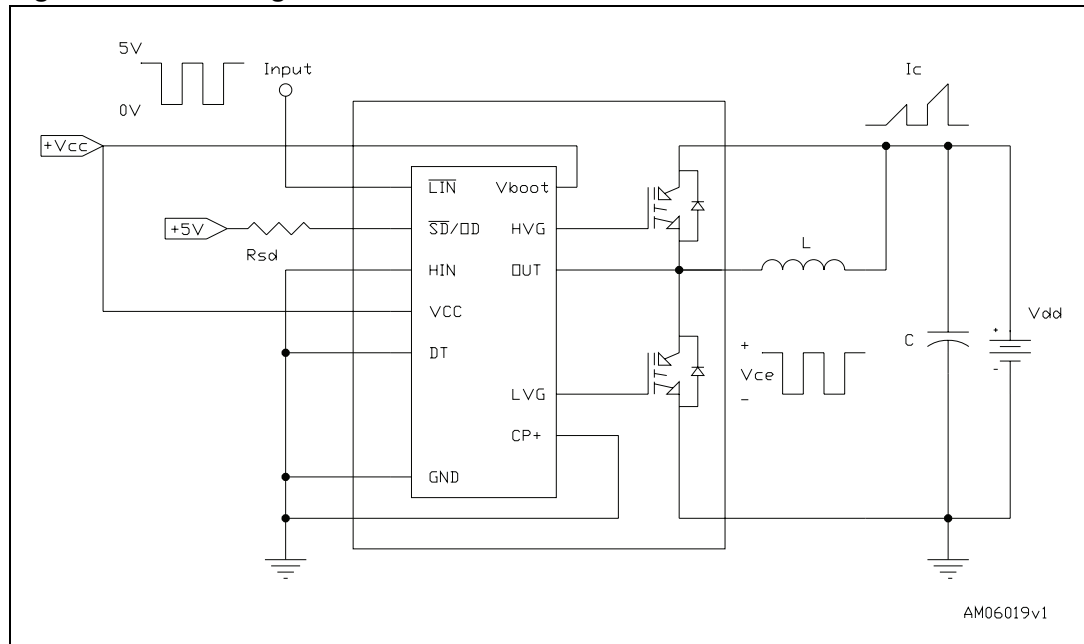

Figure 4. Switching time definition

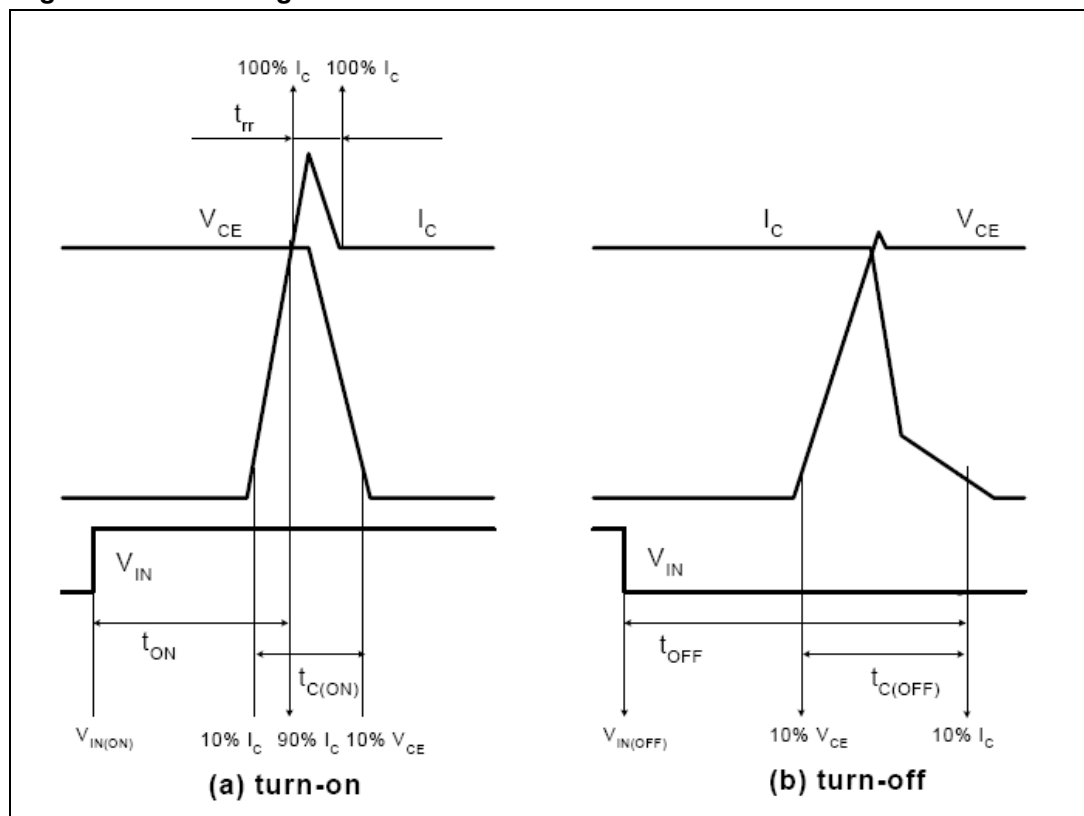

Figure 4 "Switching time definition" refers to HIN inputs (active high). For L1N inputs (active low), VIN polarity must be inverted for turn-on and turn-off.

3.1 Control part

Table 8. Low voltage power supply

Symbol	Parameter	Test conditions	Min.	Typ.	Max.	Unit
V_{cc_hys}	V_{cc} UV hysteresis		1.2	1.5	1.8	V
V_{cc_thON}	V_{cc} UV turn ON threshold		11.5	12	12.5	V
V_{cc_thOFF}	V_{cc} UV turn OFF threshold		10	10.5	11	V
I_{qccu}	Undervoltage quiescent supply current	$V_{CC} = 10\text{ V}$ $\overline{SD}/OD = 5\text{ V}; \overline{LIN} = 5\text{ V};$ $HIN = 0, CIN = 0$			450	μA
I_{qcc}	Quiescent current	$V_{cc} = 15\text{ V}$ $\overline{SD}/OD = 5\text{ V}; \overline{LIN} = 5\text{ V}$ $HIN = 0, CIN = 0$			3.5	mA
V_{ref}	Internal comparator (CIN) reference voltage		0.5	0.54	0.58	V

Table 9. Bootstrapped voltage

Symbol	Parameter	Test conditions	Min.	Typ.	Max.	Unit
V_{BS_hys}	V_{BS} UV hysteresis		1.2	1.5	1.8	V
V_{BS_thON}	V_{BS} UV turn ON threshold		10.6	11.5	12.4	V
V_{BS_thOFF}	V_{BS} UV turn OFF threshold		9.1	10	10.9	V
I_{QBSU}	Undervoltage V_{BS} quiescent current	$V_{BS} = 10\text{ V}$ $\overline{SD}/OD = 5\text{ V}; \overline{LIN}$ and $HIN = 5\text{ V}; CIN = 0$		70	110	μA
I_{QBS}	V_{BS} quiescent current	$V_{BS} = 15\text{ V}$ $\overline{SD}/OD = 5\text{ V}; \overline{LIN}$ and $HIN = 5\text{ V}; CIN = 0$		150	210	μA
$R_{DS(on)}$	Bootstrap driver on resistance	LVG ON		120		Ω

Table 10. Logic inputs

Symbol	Parameter	Test conditions	Min.	Typ.	Max.	Unit
V_{il}	Low logic level voltage				0.8	V
V_{ih}	High logic level voltage		2.25			V
I_{HINh}	HIN logic "1" input bias current	$HIN = 15\text{ V}$	110	175	260	μA
I_{HINl}	HIN logic "0" input bias current	$HIN = 0\text{ V}$			1	μA
I_{LINl}	\overline{LIN} logic "1" input bias current	$\overline{LIN} = 0\text{ V}$	3	6	20	μA
I_{LINh}	\overline{LIN} logic "0" input bias current	$\overline{LIN} = 15\text{ V}$			1	μA
I_{SDh}	\overline{SD} logic "0" input bias current	$\overline{SD} = 15\text{ V}$	30	120	300	μA
I_{SDl}	\overline{SD} logic "1" input bias current	$\overline{SD} = 0\text{ V}$			3	μA
Dt	Dead time	see Figure 7		600		ns

Table 11. Sense comparator characteristics ($V_{CC} = 15\text{ V}$)

Symbol	Parameter	Test conditions	Min.	Typ.	Max.	Unit
I_{ib}	Input bias current	$V_{CP+} = 1\text{ V}$	-		3	μA
V_{ol}	Open-drain low-level output voltage	$I_{od} = -3\text{ mA}$	-		0.5	V
t_{d_comp}	Comparator delay	$\overline{\text{SD}}/\text{OD}$ pulled to 5 V through 100 k Ω resistor	-	90	130	ns
SR	Slew rate	$C_L = 180\text{ pF}$; $R_{pu} = 5\text{ k}\Omega$	-	60		V/ μsec
t_{sd}	Shut down to high / low side driver propagation delay	$V_{OUT} = 0$, $V_{boot} = V_{CC}$, $V_{IN} = 0\text{ to }3.3\text{ V}$	50	125	200	ns
t_{isd}	Comparator triggering to high / low side driver turn-off propagation delay	Measured applying a voltage step from 0 V to 3.3 V to pin CIN_i	50	200	250	

Table 12. Truth table

Condition	Logic input (V_i)			Output	
	$\overline{\text{SD}}/\text{OD}$	$\overline{\text{LIN}}$	HIN	LVG	HVG
Shutdown enable half-bridge tri-state	L	X	X	L	L
Interlocking half-bridge tri-state	H	L	H	L	L
0 "logic state" half-bridge tri-state	H	H	L	L	L
1 "logic state" low side direct driving	H	L	L	H	L
1 "logic state" high side direct driving	H	H	H	L	H

Note: X: don't care

Figure 5. Maximum $I_{C(RMS)}$ current vs. switching frequency (1)

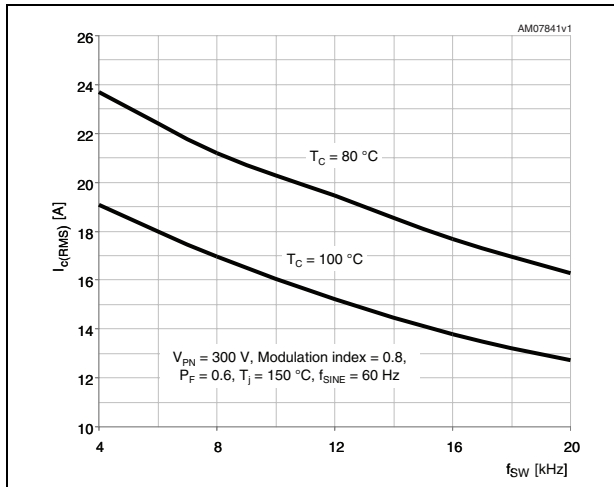
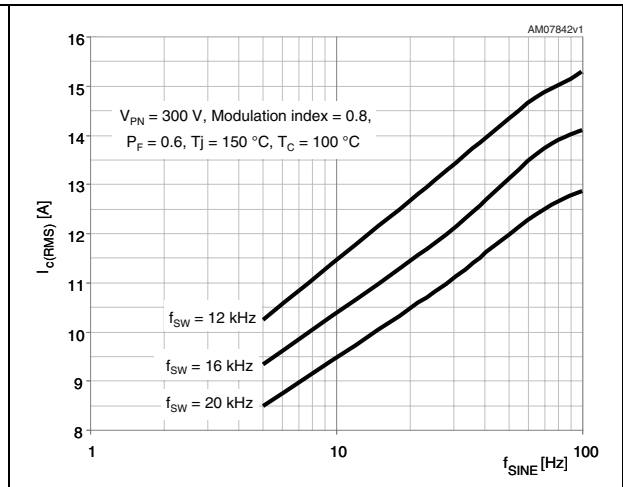

Figure 6. Maximum $I_{C(RMS)}$ current vs. f_{SINE} (1)



1. Simulated curves refer to typical IGBT parameters and maximum R_{thj-c} .

3.2 Waveforms definitions

Figure 7. Dead time and interlocking waveforms definitions

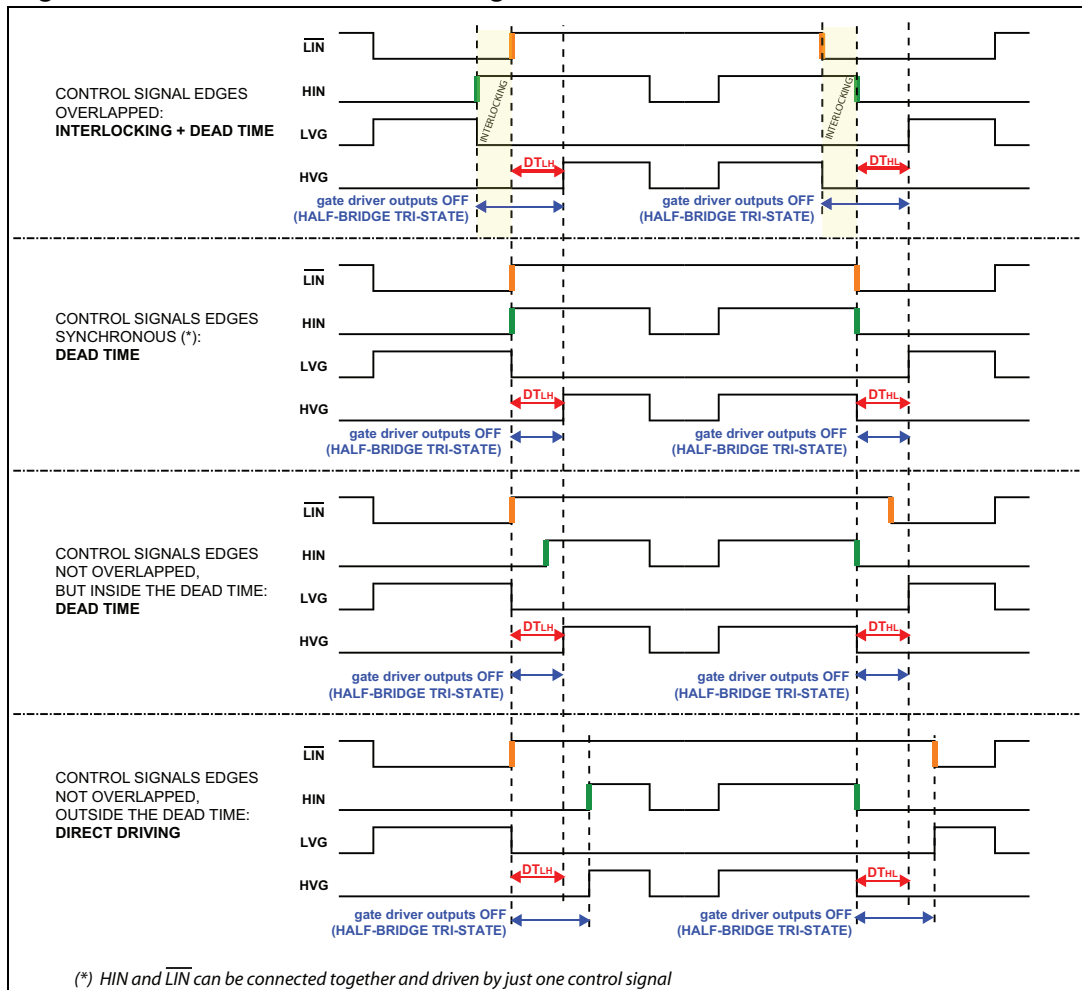

4 Smart shutdown function

The STGIPS20K60 integrates a comparator for fault sensing purposes. The comparator non-inverting input (CIN) can be connected to an external shunt resistor in order to implement a simple over-current protection function. When the comparator triggers, the device is set in shutdown state and both its outputs are set to low-level leading the half-bridge in tri-state. In the common overcurrent protection architectures the comparator output is usually connected to the shutdown input through a RC network, in order to provide a mono-stable circuit, which implements a protection time that follows the fault condition. Our smart shutdown architecture allows to immediately turn-off the output gate driver in case of overcurrent, the fault signal has a preferential path which directly switches off the outputs. The time delay between the fault and the outputs turn-off is no more dependent on the RC values of the external network connected to the shutdown pin. At the same time the internal logic turns on the open-drain output and holds it on until the shutdown voltage goes below the logic input lower threshold. Finally the smart shutdown function provides the possibility to increase the real disable time without increasing the constant time of the external RC network.

Figure 8. Smart shutdown timing waveforms

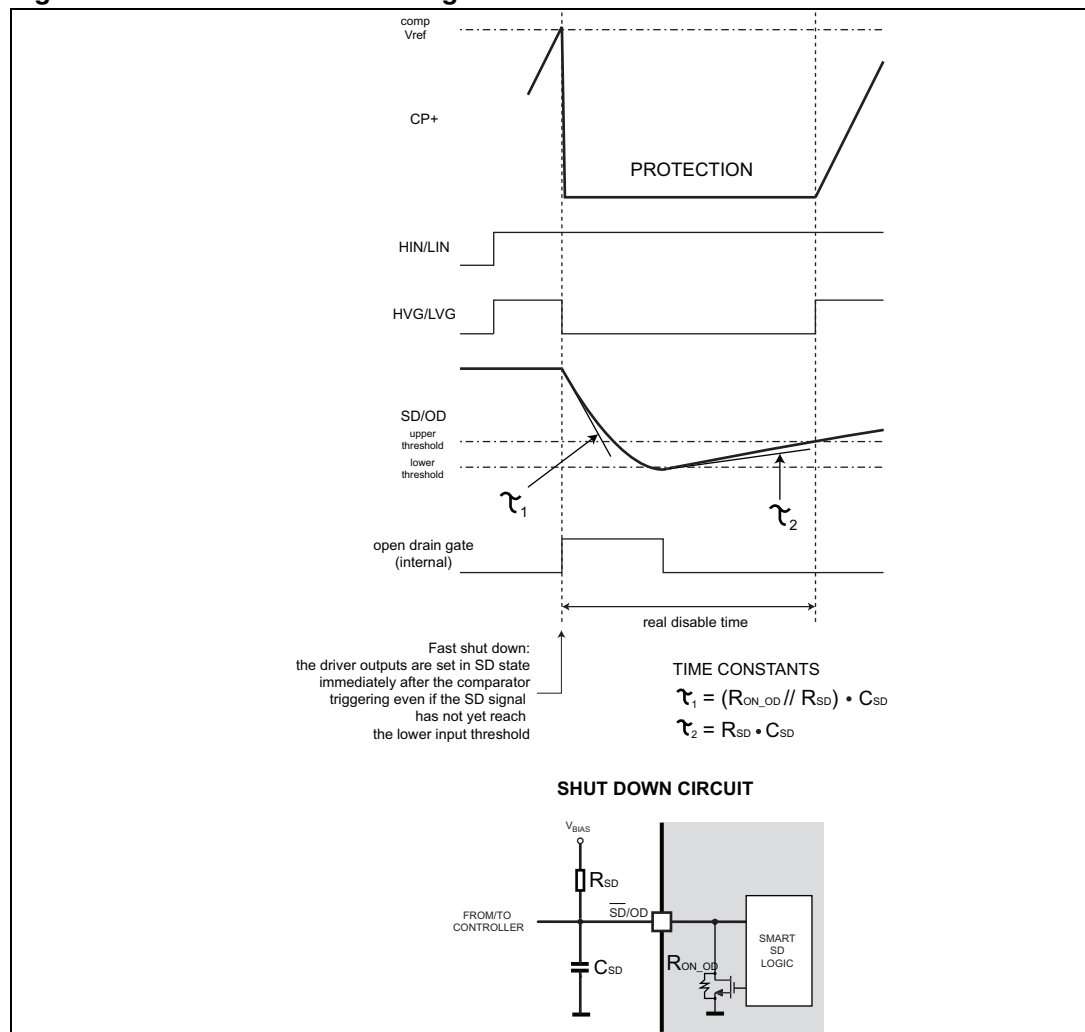

Pls refer to [Table 11](#) for internal propagation delay time details.

5 Applications information

Figure 9. Typical application circuit

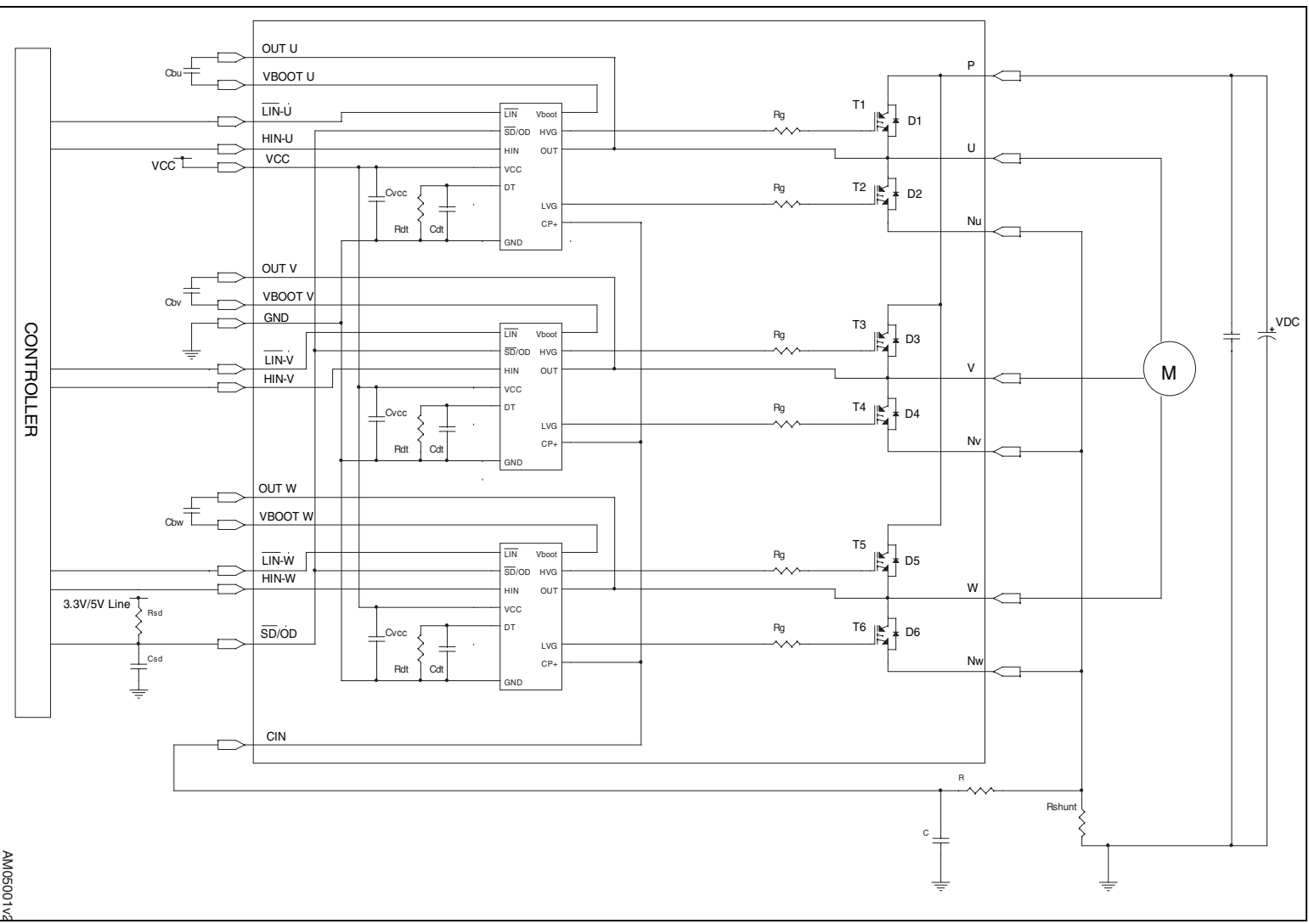

AM05001V2

5.1 Recommendations

- Input signal HIN is active high logic. A 85 k Ω (typ.) pull down resistor is built-in for each high side input. If an external RC filter is used, for noise immunity, pay attention to the variation of the input signal level.
- Input signal $\overline{\text{LIN}}$ is active low logic. A 720 k Ω (typ.) pull-up resistor, connected to an internal 5 V regulator through a diode, is built-in for each low side input.
- To prevent the input signals oscillation, the wiring of each input should be as short as possible.
- By integrating an application specific type HVIC inside the module, direct coupling to MCU terminals without any opto-coupler is possible.
- Each capacitor should be located as nearby the pins of IPM as possible.
- Low inductance shunt resistors should be used for phase leg current sensing.
- Electrolytic bus capacitors should be mounted as close to the module bus terminals as possible. Additional high frequency ceramic capacitor mounted close to the module pins will further improve performance.
- The $\overline{\text{SD}}/\text{OD}$ signal should be pulled up to 5 V / 3.3 V with an external resistor (see [Section 4: Smart shutdown function](#) for detailed info).

Table 13. Recommended operating conditions

Symbol	Parameter	Conditions	Value			Unit
			Min.	Typ.	Max.	
V _{PN}	Supply Voltage	Applied between P-Nu,Nv,Nw		300	400	V
V _{CC}	Control supply voltage	Applied between V _{CC} -GND	13.5	15	18	V
V _{BS}	High side bias voltage	Applied between V _{BOOTi} -OUT _i for i=U,V,W	13		18	V
t _{dead}	Blanking time to prevent Arm-short	For each input signal	1			μs
f _{PWM}	PWM input signal	-40°C < T _c < 100°C -40°C < T _j < 125°C			20	kHz

6 Package mechanical data

In order to meet environmental requirements, ST offers these devices in different grades of ECOPACK[®] packages, depending on their level of environmental compliance. ECOPACK[®] specifications, grade definitions and product status are available at: www.st.com. ECOPACK[®] is an ST trademark.

Please refer to dedicated technical note TN0107 for mounting instructions.

Table 14. SDIP-25L package mechanical data

Dim.	(mm.)		
	Min.	Typ.	Max.
A	44		44.8
A1	0.95		1.75
A2	1.2		2
A3	39		39.8
B	21.6		22.4
B1	11.45		12.25
B2	24.83	25.22	25.63
C	5		5.8
C1	6.4		7.4
C2	11.1		12.1
e	1.95	2.35	2.75
e1	3.2	3.6	4
e2	4.3	4.7	5.1
e3	6.1	6.5	6.9
F	0.8	1.0	1.2
F1	0.3	0.5	0.7
R	1.35		2.15
T	0.4	0.55	0.7

7 Revision history

Table 15. Document revision history

Date	Revision	Changes
10-Aug-2009	1	Initial release
01-Jul-2010	2	Document status promoted from preliminary to datasheet. Updated package mechanical data (Section 6: Package mechanical data). Minor text changes to improve readability.
23-Sep-2010	3	Updated: Table 3 , 5 , 10 and Table 11 . Modified: Figure 5 and Figure 6 .

Please Read Carefully:

Information in this document is provided solely in connection with ST products. STMicroelectronics NV and its subsidiaries ("ST") reserve the right to make changes, corrections, modifications or improvements, to this document, and the products and services described herein at any time, without notice.

All ST products are sold pursuant to ST's terms and conditions of sale.

Purchasers are solely responsible for the choice, selection and use of the ST products and services described herein, and ST assumes no liability whatsoever relating to the choice, selection or use of the ST products and services described herein.

No license, express or implied, by estoppel or otherwise, to any intellectual property rights is granted under this document. If any part of this document refers to any third party products or services it shall not be deemed a license grant by ST for the use of such third party products or services, or any intellectual property contained therein or considered as a warranty covering the use in any manner whatsoever of such third party products or services or any intellectual property contained therein.

UNLESS OTHERWISE SET FORTH IN ST'S TERMS AND CONDITIONS OF SALE ST DISCLAIMS ANY EXPRESS OR IMPLIED WARRANTY WITH RESPECT TO THE USE AND/OR SALE OF ST PRODUCTS INCLUDING WITHOUT LIMITATION IMPLIED WARRANTIES OF MERCHANTABILITY, FITNESS FOR A PARTICULAR PURPOSE (AND THEIR EQUIVALENTS UNDER THE LAWS OF ANY JURISDICTION), OR INFRINGEMENT OF ANY PATENT, COPYRIGHT OR OTHER INTELLECTUAL PROPERTY RIGHT.

UNLESS EXPRESSLY APPROVED IN WRITING BY AN AUTHORIZED ST REPRESENTATIVE, ST PRODUCTS ARE NOT RECOMMENDED, AUTHORIZED OR WARRANTED FOR USE IN MILITARY, AIR CRAFT, SPACE, LIFE SAVING, OR LIFE SUSTAINING APPLICATIONS, NOR IN PRODUCTS OR SYSTEMS WHERE FAILURE OR MALFUNCTION MAY RESULT IN PERSONAL INJURY, DEATH, OR SEVERE PROPERTY OR ENVIRONMENTAL DAMAGE. ST PRODUCTS WHICH ARE NOT SPECIFIED AS "AUTOMOTIVE GRADE" MAY ONLY BE USED IN AUTOMOTIVE APPLICATIONS AT USER'S OWN RISK.

Resale of ST products with provisions different from the statements and/or technical features set forth in this document shall immediately void any warranty granted by ST for the ST product or service described herein and shall not create or extend in any manner whatsoever, any liability of ST.

ST and the ST logo are trademarks or registered trademarks of ST in various countries.

Information in this document supersedes and replaces all information previously supplied.

The ST logo is a registered trademark of STMicroelectronics. All other names are the property of their respective owners.

© 2010 STMicroelectronics - All rights reserved

STMicroelectronics group of companies

Australia - Belgium - Brazil - Canada - China - Czech Republic - Finland - France - Germany - Hong Kong - India - Israel - Italy - Japan - Malaysia - Malta - Morocco - Philippines - Singapore - Spain - Sweden - Switzerland - United Kingdom - United States of America

www.st.com