



Chipsmall Limited consists of a professional team with an average of over 10 year of expertise in the distribution of electronic components. Based in Hongkong, we have already established firm and mutual-benefit business relationships with customers from,Europe,America and south Asia,supplying obsolete and hard-to-find components to meet their specific needs.

With the principle of “Quality Parts,Customers Priority,Honest Operation,and Considerate Service”,our business mainly focus on the distribution of electronic components. Line cards we deal with include Microchip,ALPS,ROHM,Xilinx,Pulse,ON,Everlight and Freescale. Main products comprise IC,Modules,Potentiometer,IC Socket,Relay,Connector.Our parts cover such applications as commercial,industrial, and automotives areas.

We are looking forward to setting up business relationship with you and hope to provide you with the best service and solution. Let us make a better world for our industry!



Contact us

Tel: +86-755-8981 8866 Fax: +86-755-8427 6832

Email & Skype: info@chipsmall.com Web: www.chipsmall.com

Address: A1208, Overseas Decoration Building, #122 Zhenhua RD., Futian, Shenzhen, China





STGP3NB60K STGD3NB60K

N-CHANNEL 6A - 600V - TO-220 / DPAK SHORT CIRCUIT PROOF PowerMESH™ IGBT

TYPE	V _{CE(S)}	V _{CE(sat)} (Max) @ 25°C	I _C (#) @100°C
STGP3NB60K	600 V	< 2.8 V	6 A
STGD3NB60K	600 V	< 2.8 V	6 A

- HIGH INPUT IMPEDANCE (VOLTAGE DRIVEN)
- LOW ON-VOLTAGE DROP (V_{cesat})
- LOW GATE CHARGE
- HIGH CURRENT CAPABILITY
- OFF LOSSES INCLUDE TAIL CURRENT
- HIGH FREQUENCY OPERATION
- SHORT CIRCUIT RATED

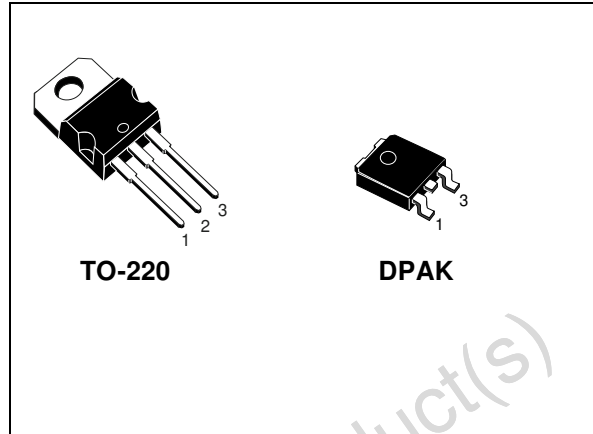

DESCRIPTION

Using the latest high voltage technology based on a patented strip layout, STMicroelectronics has designed an advanced family of IGBTs, the PowerMESH™ IGBTs, with outstanding performances. The suffix "K" identifies a family optimized for high frequency motor control applications with short circuit withstand capability.

APPLICATIONS

- HIGH FREQUENCY MOTOR CONTROLS
- SMPS AND PFC IN BOTH HARD SWITCHING AND RESONANT TOPOLOGIES

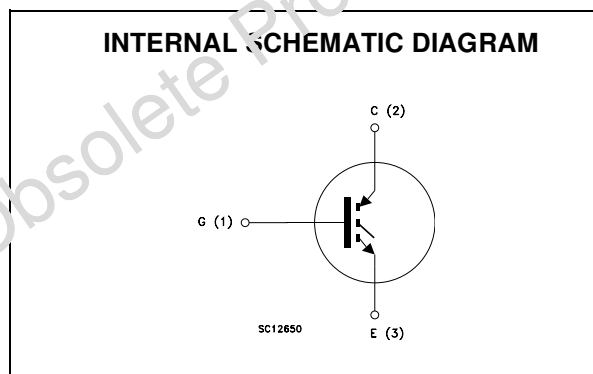

ORDERING INFORMATION

SALES TYPE	MARKING	PACKAGE	PACKAGING
STGP3NB60K	GP3NB60K	TO-220	TUBE
STGD3NB60KT4	GD3NB60K	DPAK	TAPE & REEL

STGP3NB60K - STGD3NB60K

ABSOLUTE MAXIMUM RATINGS

Symbol	Parameter	Value	Unit
V_{CES}	Collector-Emitter Voltage ($V_{GS} = 0$)	600	V
V_{ECR}	Emitter-Collector Voltage	20	V
V_{GE}	Gate-Emitter Voltage	± 20	V
I_C	Collector Current (continuous) at $T_C = 25^\circ\text{C}$ (#)	10	A
I_C	Collector Current (continuous) at $T_C = 100^\circ\text{C}$ (#)	6	A
I_{CM} (■)	Collector Current (pulsed)	24	A
P_{TOT}	Total Dissipation at $T_C = 25^\circ\text{C}$	50	W
	Derating Factor	0.4	W/°C
T_{stg}	Storage Temperature	- 55 to 150	°C
T_j	Max. Operating Junction Temperature	150	°C

(■) Pulse width limited by safe operating area

THERMAL DATA

		TO-220	DPAK	
Rthj-case	Thermal Resistance Junction-case Max	2.5		°C/W
Rthj-amb	Thermal Resistance Junction-ambient Max	62.5	100	°C/W

ELECTRICAL CHARACTERISTICS (TCASE = 25 °C UNLESS OTHERWISE SPECIFIED)

MAIN PARAMETERS

Symbol	Parameter	Test Conditions	Min.	Typ.	Max.	Unit
$V_{BR}(CES)$	Collector-Emitter Breakdown Voltage	$I_C = 250 \mu\text{A}$, $V_{GE} = 0$	600			V
I_{CES}	Collector cut-off ($V_{GE} = 0$)	$V_{CE} = \text{Max Rating}$, $T_C = 25^\circ\text{C}$ $V_{CE} = \text{Max Rating}$, $T_C = 125^\circ\text{C}$			50 500	μA μA
I_{GES}	Gate-Emitter Leakage Current ($V_{CE} = 0$)	$V_{GE} = \pm 20\text{V}$, $V_{CE} = 0$			± 100	nA
$V_{GE(th)}$	Gate Threshold Voltage	$V_{CE} = V_{GE}$, $I_C = 250\mu\text{A}$	5		7	V
$V_{CE(sat)}$	Collector-Emitter Saturation Voltage	$V_{GE} = 15\text{V}$, $I_C = 3 \text{ A}$ $V_{GE} = 15\text{V}$, $I_C = 3 \text{ A}$, $T_j = 125^\circ\text{C}$		2.3 1.9	2.8	V V

SWITCHING PARAMETERS

Symbol	Parameter	Test Conditions	Min.	Typ.	Max.	Unit
g_{fs}	Forward Transconductance	$V_{CE} = 25V, I_C = 3 A$		2.4		S
C_{ies} C_{oes} C_{res}	Input Capacitance Output Capacitance Reverse Transfer Capacitance	$V_{CE} = 25V, f = 1 MHz, V_{GE} = 0$		220 50 5.8		pF pF pF
Q_g Q_{ge} Q_{gc}	Total Gate Charge Gate-Emitter Charge Gate-Collector Charge	$V_{CE} = 480V, I_C = 3 A,$ $V_{GE} = 15V$		14 3.3 7.5	18	nC nC nC
tscw	Short Circuit Withstand Time	$V_{ce} = 0.5 V_{BR(CES)}, V_{GE}=15V,$ $T_j = 125^\circ C, R_G = 10 \Omega$	10			μs
$t_{d(on)}$ t_r	Turn-on Delay Time Rise Time	$V_{CC} = 480 V, I_C = 3 A$ $R_G = 10\Omega, V_{GE} = 15 V$		14 5		ns ns
$(di/dt)_{on}$ E _{on}	Turn-on Current Slope Turn-on Switching Losses	$V_{CC}= 480 V, I_C = 3 A R_G=10\Omega$ $V_{GE} = 15 V, T_j = 125^\circ C$		520 30		A/ μs μJ
t_c $t_r(V_{off})$ $t_{d(off)}$ t_f $E_{off(**)}$ E _{ts}	Cross-over Time Off Voltage Rise Time Delay Time Fall Time Turn-off Switching Loss Total Switching Loss	$V_{CC} = 480 V, I_C = 3 A,$ $R_{GE} = 10 \Omega, V_{GE} = 15 V$ $T_j = 25^\circ C$		90 20 33 100 58 85		ns ns ns ns μJ μJ
t_c $t_r(V_{off})$ $t_{d(off)}$ t_f $E_{off(**)}$ E _{ts}	Cross-over Time Off Voltage Rise Time Delay Time Fall Time Turn-off Switching Loss Total Switching Loss	$V_{CC} = 480 V, I_C = 3 A,$ $R_{GE} = 10 \Omega, V_{GE} = 15 V$ $T_j = 125^\circ C$		190 54 90 130 111 195		ns ns ns ns μJ μJ

Note: 1. Pulsed: Pulse duration = 300 μs , duty cycle 1.5 %.
 2. Pulse width limited by max. junction temperature.
 (**)Losses include Also the Tail (Jedec Standardization)

(#) Calculated according to the iterative formula:

$$I_C(T_C) = \frac{T_{JMAX} - T_C}{R_{THJ-C} \times V_{CESAT(MAX)}(T_C, I_C)}$$

Output Characteristics

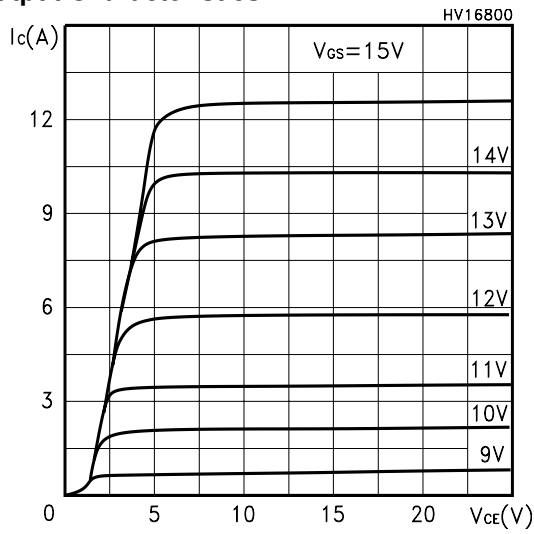

Transfer Characteristics

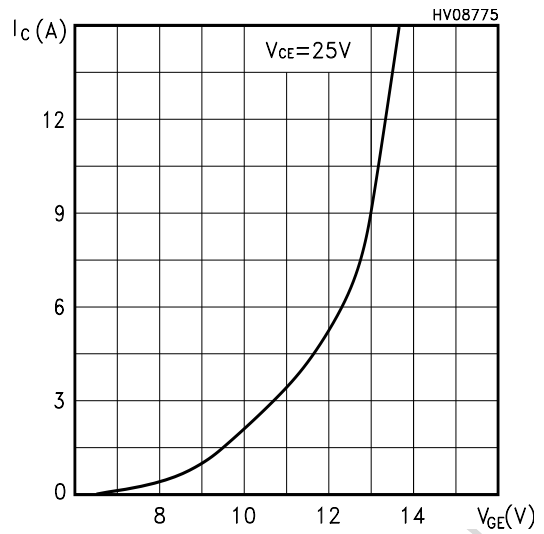

Transconductance

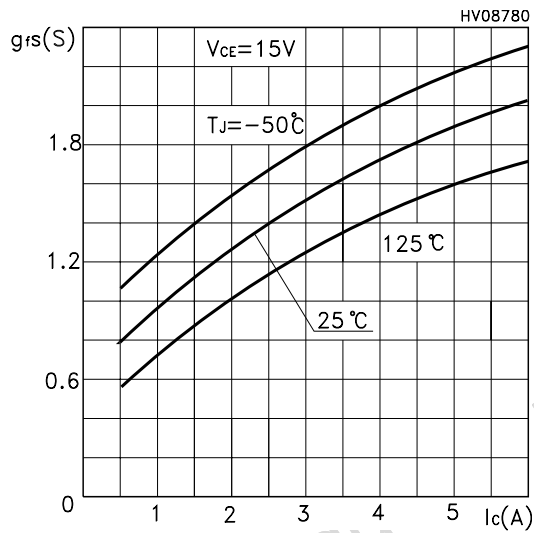

Normalized Collector-Emitter On Voltage vs Temp.

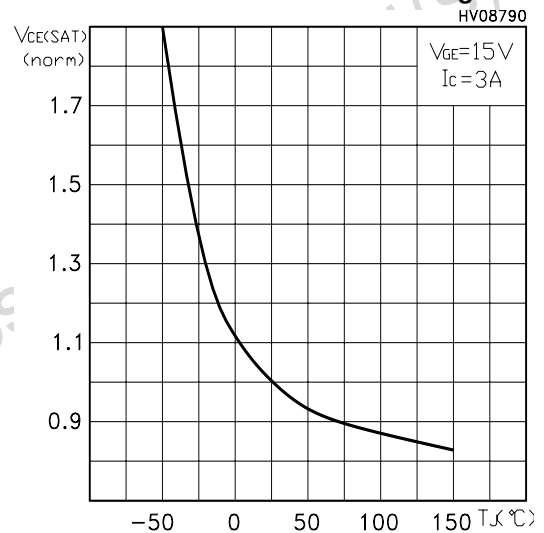

Collector-Emitter On Voltage vs Collector Current

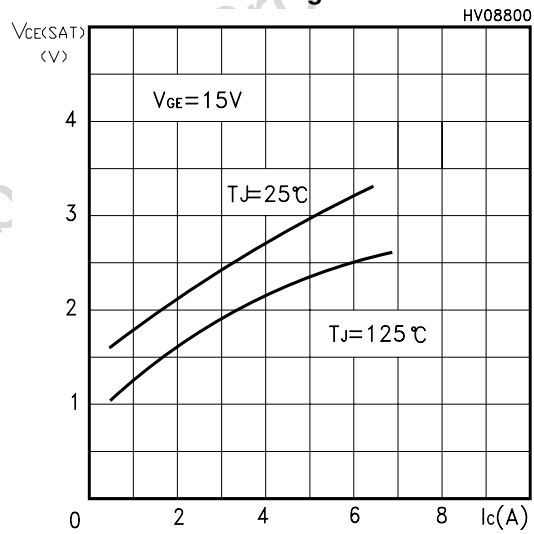

Gate Threshold vs Temperature

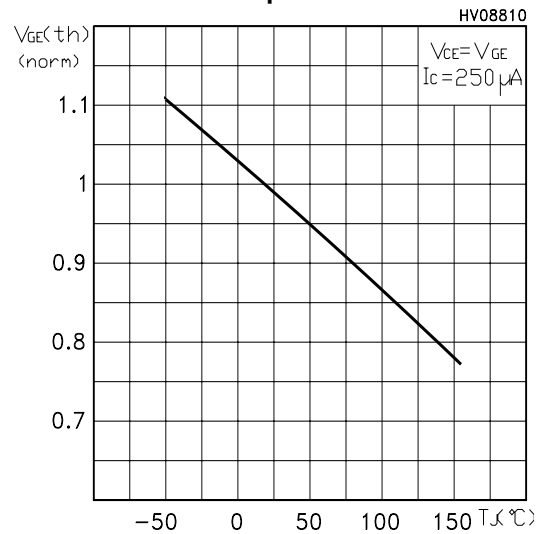

Normalized Breakdown Voltage vs Temperature

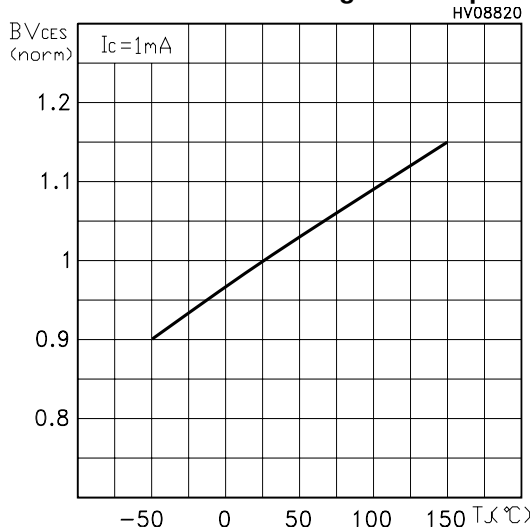

Capacitance Variations

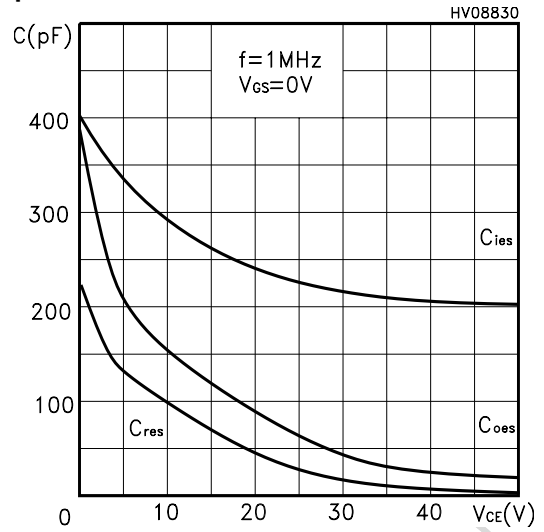

Gate Charge vs Gate-Emitter Voltage

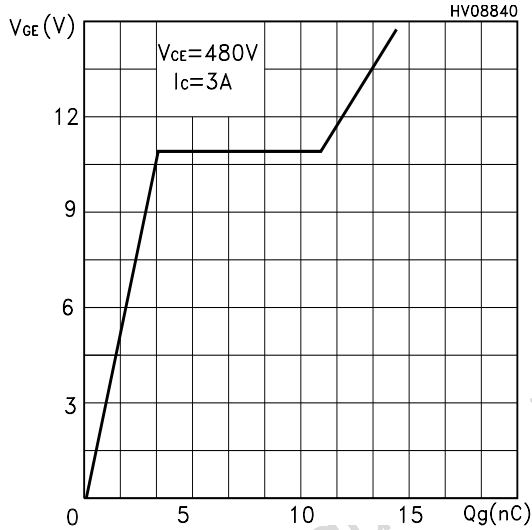

Total Switching Losses vs Gate Resistance

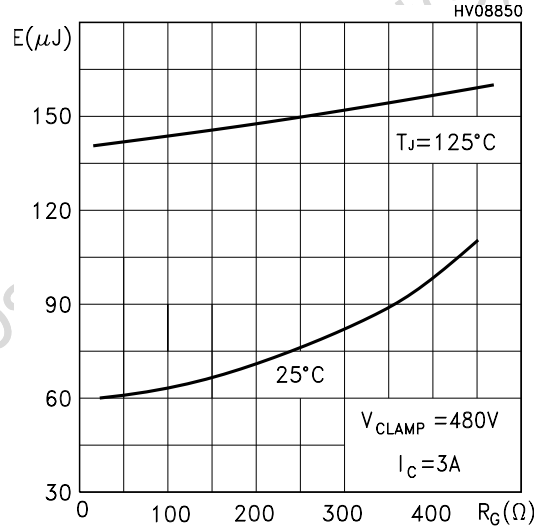

Total Switching Losses vs Temperature

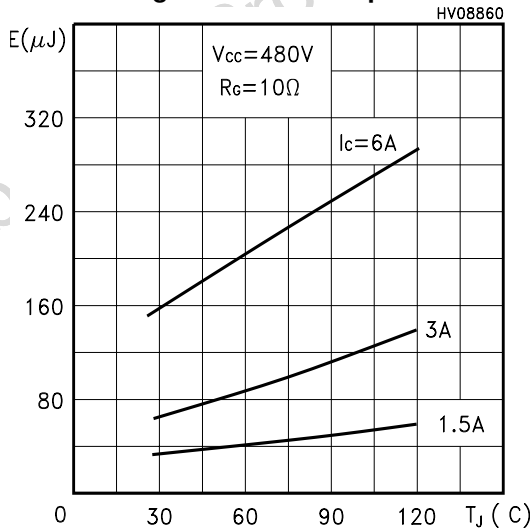

Turn-Off SOA

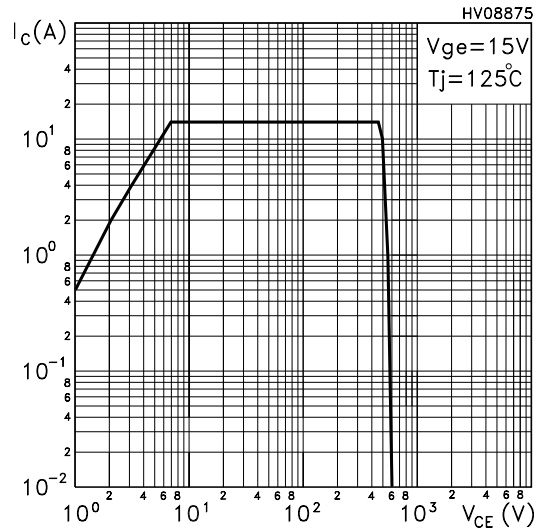

Thermal Impedance for TO-220

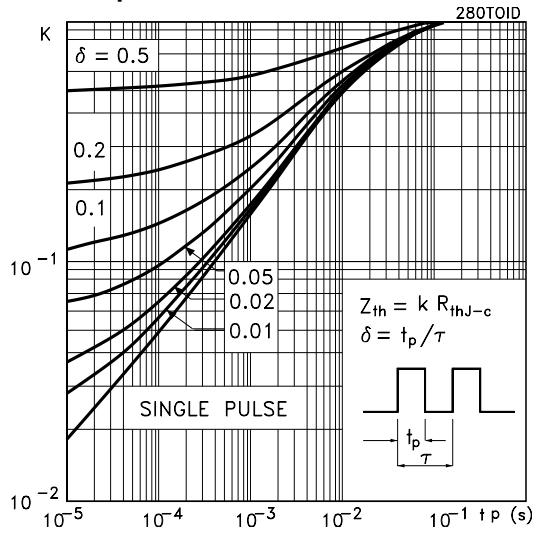

Thermal Impedance for DPAK

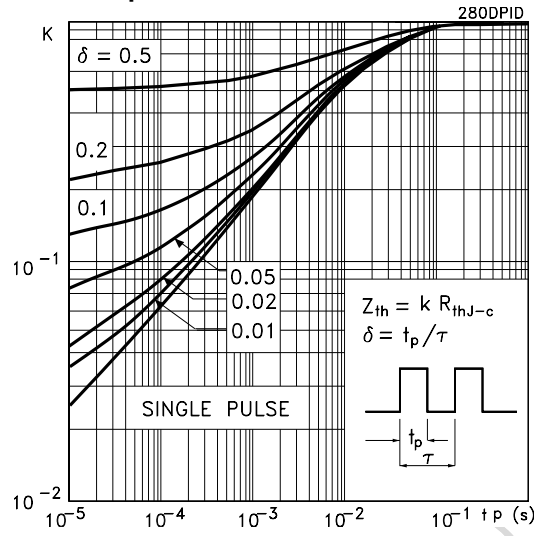

Obsolete Product(s) - Obsolete Product(s)

Fig. 1: Gate Charge test Circuit

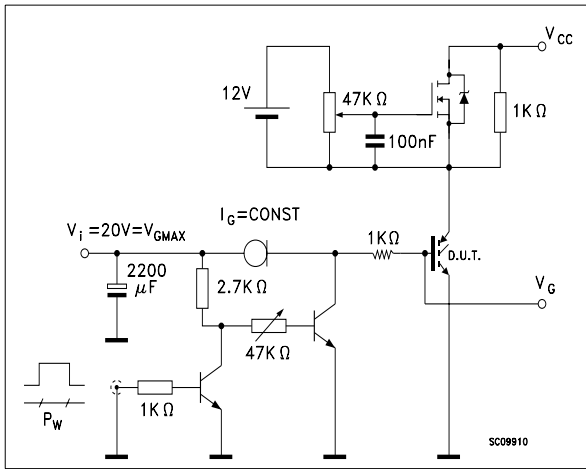
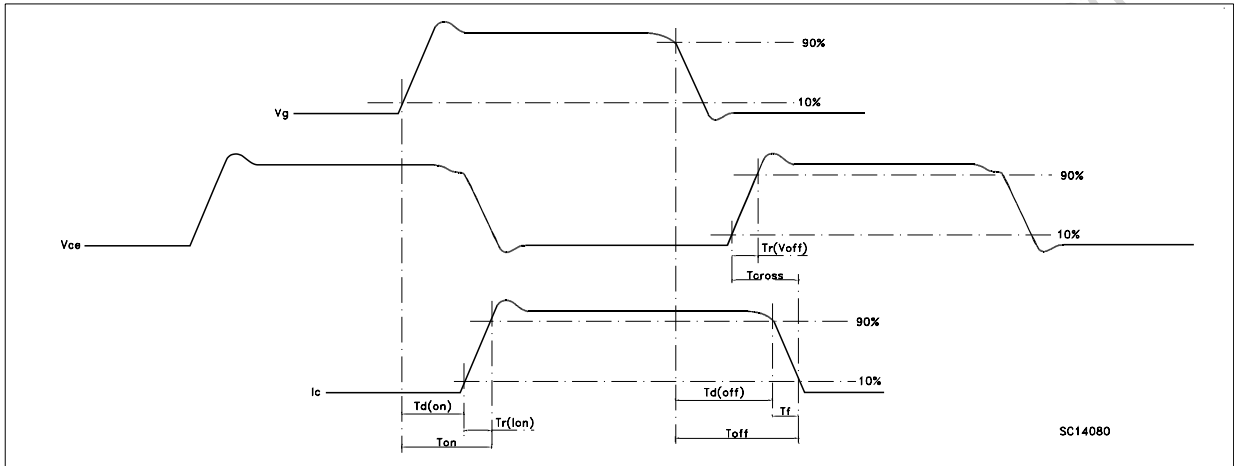
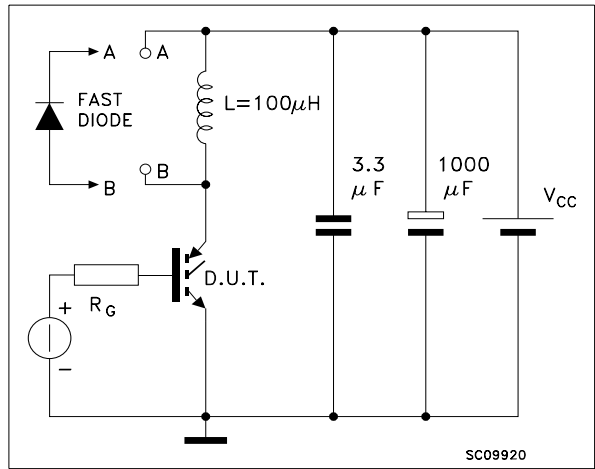

Fig. 2: Test Circuit For Inductive Load Switching



Obsolete Product

TO-220 MECHANICAL DATA

DIM.	mm.			inch		
	MIN.	TYP.	MAX.	MIN.	TYP.	MAX.
A	4.40		4.60	0.173		0.181
b	0.61		0.88	0.024		0.034
b1	1.15		1.70	0.045		0.066
c	0.49		0.70	0.019		0.027
D	15.25		15.75	0.60		0.620
E	10		10.40	0.393		0.409
e	2.40		2.70	0.094		0.106
e1	4.95		5.15	0.194		0.202
F	1.23		1.32	0.048		0.052
H1	6.20		6.60	0.244		0.256
J1	2.40		2.72	0.094		0.107
L	13		14	0.511		0.551
L1	3.50		3.93	0.137		0.154
L20		16.40			0.645	
L30		28.90			1.137	
øP	3.75		3.85	0.147		0.151
Q	2.65		2.95	0.104		0.116

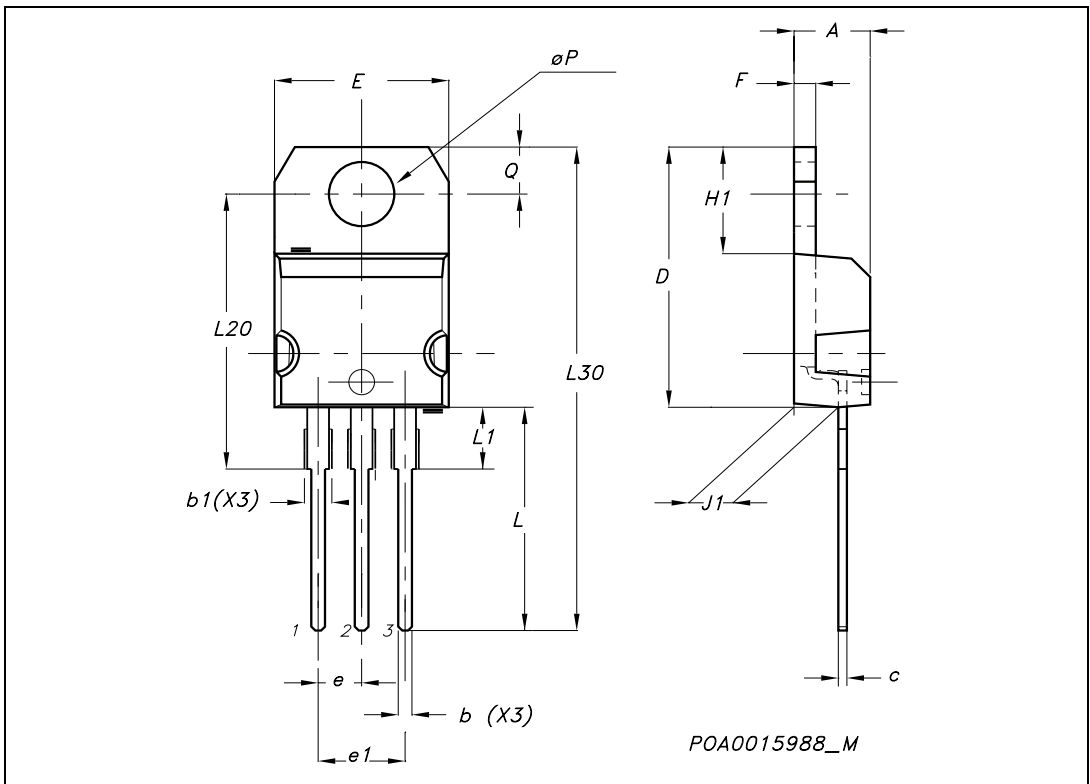

TO-252 (DPAK) MECHANICAL DATA

DIM.	mm			inch		
	MIN.	TYP.	MAX.	MIN.	TYP.	MAX.
A	2.20		2.40	0.087		0.094
A1	0.90		1.10	0.035		0.043
A2	0.03		0.23	0.001		0.009
B	0.64		0.90	0.025		0.035
B2	5.20		5.40	0.204		0.213
C	0.45		0.60	0.018		0.024
C2	0.48		0.60	0.019		0.024
D	6.00		6.20	0.236		0.244
E	6.40		6.60	0.252		0.260
G	4.40		4.60	0.173		0.181
H	9.35		10.10	0.368		0.398
L2		0.8			0.031	
L4	0.60		1.00	0.024		0.039
V2	0°		8°	0°		0°

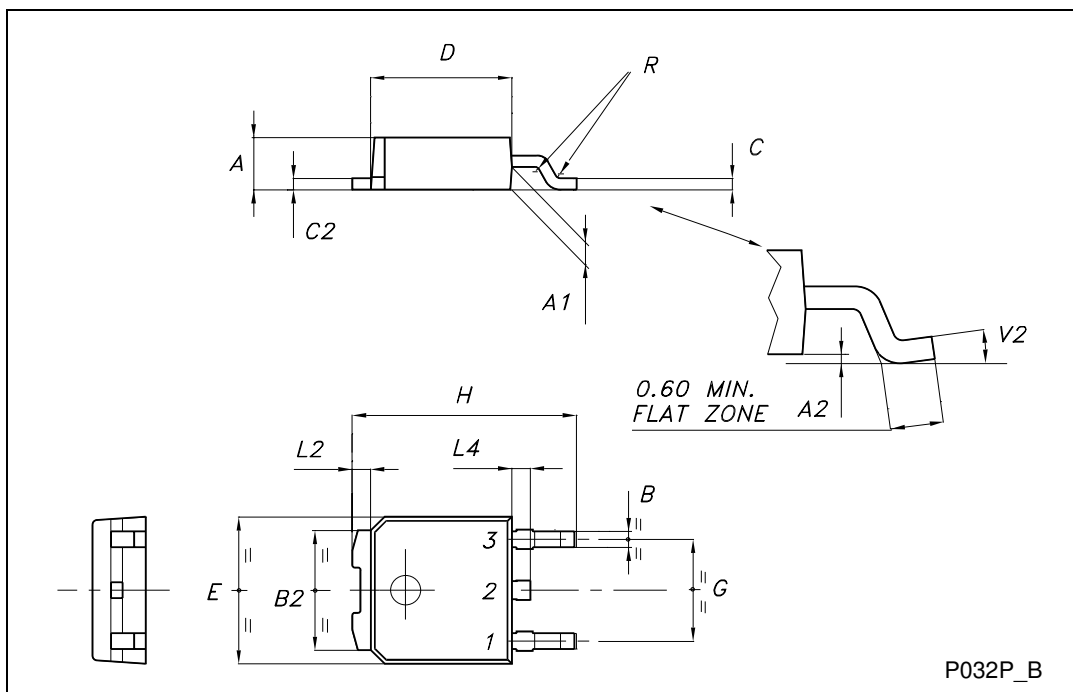

DPAK FOOTPRINT

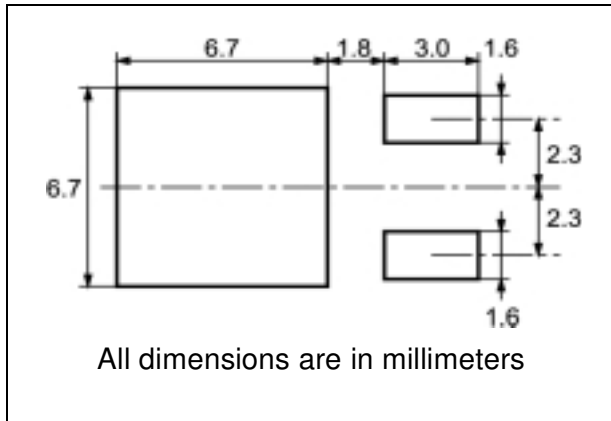

TUBE SHIPMENT (no suffix)*

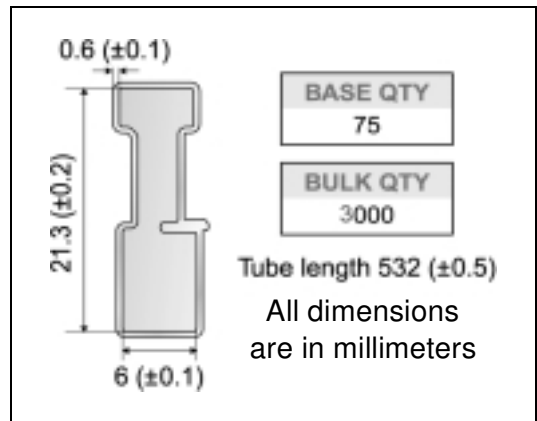

TAPE AND REEL SHIPMENT (suffix "T4")*

40 mm min. Access hole at slot location
Tape slot in core for tape start 2.5mm min. width
Full radius
G measured at hub

REEL MECHANICAL DATA

DIM.	mm		inch	
	MIN.	MAX.	MIN.	MAX.
A		330		12.992
B	1.5		0.059	
C	12.8	13.2	0.504	0.520
D	20.2		0.795	
G	16.4	18.4	0.645	0.724
N	50		1.968	
T		22.4		0.881

BASE QTY	BULK QTY
2500	2500

TAPE MECHANICAL DATA

DIM.	mm		inch	
	MIN.	MAX.	MIN.	MAX.
A0	6.8	7	0.267	0.275
B0	10.4	10.6	0.409	0.417
B1		12.1		0.476
D	1.5	1.6	0.059	0.063
D1	1.5		0.059	
E	1.65	1.85	0.065	0.073
F	7.4	7.6	0.291	0.299
K0	2.55	2.75	0.100	0.108
P0	3.9	4.1	0.153	0.161
P1	7.9	8.1	0.311	0.319
P2	1.9	2.1	0.075	0.082
R	40		1.574	
W	15.7	16.3	0.618	0.641

For machine ref only including draft and radii concentric around B0
10 pitches cumulative tolerance on tape +/- 0.2 mm
User Direction of Feed
FEED DIRECTION
Bending radius R min.

* on sales type

Information furnished is believed to be accurate and reliable. However, STMicroelectronics assumes no responsibility for the consequences of use of such information nor for any infringement of patents or other rights of third parties which may result from its use. No license is granted by implication or otherwise under any patent or patent rights of STMicroelectronics. Specifications mentioned in this publication are subject to change without notice. This publication supersedes and replaces all information previously supplied. STMicroelectronics products are not authorized for use as critical components in life support devices or systems without express written approval of STMicroelectronics.

The ST logo is a registered trademark of STMicroelectronics
All other names are the property of their respective owners

© 2004 STMicroelectronics - All Rights Reserved
STMicroelectronics GROUP OF COMPANIES

Australia - Belgium - Brazil - Canada - China - Czech Republic - Finland - France - Germany - Hong Kong - India - Israel - Italy - Japan -
Malaysia - Malta - Morocco - Singapore - Spain - Sweden - Switzerland - United Kingdom - United States.

<http://www.st.com>