



Chipsmall Limited consists of a professional team with an average of over 10 year of expertise in the distribution of electronic components. Based in Hongkong, we have already established firm and mutual-benefit business relationships with customers from,Europe,America and south Asia,supplying obsolete and hard-to-find components to meet their specific needs.

With the principle of “Quality Parts,Customers Priority,Honest Operation,and Considerate Service”,our business mainly focus on the distribution of electronic components. Line cards we deal with include Microchip,ALPS,ROHM,Xilinx,Pulse,ON,Everlight and Freescale. Main products comprise IC,Modules,Potentiometer,IC Socket,Relay,Connector.Our parts cover such applications as commercial,industrial, and automotives areas.

We are looking forward to setting up business relationship with you and hope to provide you with the best service and solution. Let us make a better world for our industry!



Contact us

Tel: +86-755-8981 8866 Fax: +86-755-8427 6832

Email & Skype: info@chipsmall.com Web: www.chipsmall.com

Address: A1208, Overseas Decoration Building, #122 Zhenhua RD., Futian, Shenzhen, China



MAIN APPLICATIONS

- HIGH POWER DENSITY ADAPTER
- HIGH END TV POWER SUPPLY
- OPENED FRAME SMPS

FEATURES

- Inrush current limitation circuit for off-line power supply
- Dual non-sensitive unidirectional switches in a single package
- Suitable when space and efficiency are critical
- Active after short AC line drop out with a boost converter
- High repetitive forward and reverse off-state voltage (700V)

BENEFITS

- Low consumption ($I_{pt} = 20\text{mA}$)
- High noise immunity:
($dV/dt > 500\text{V}/\mu\text{s}$ @ $T_j = 150^\circ\text{C}$)
- Low reverse current losses
- Integrated pilot driver of the power switches
- Monolithic ASDTM planar technology for better robustness and reliability

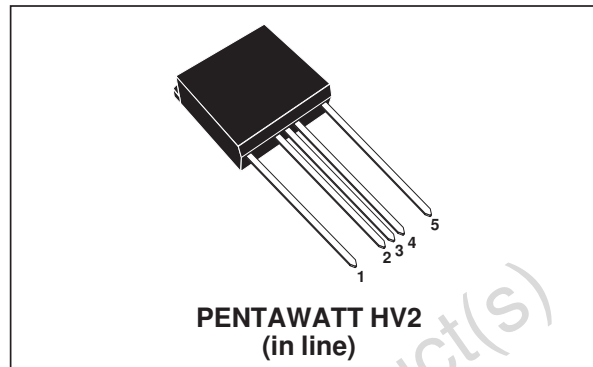

PIN OUT DESCRIPTION

Pin out designation	Description	Position
L	AC Line (switch 1)	1
Pt 1	Pilot of power switch 1	2
OUT	Output (connected to Tab)	3
Pt 2	Pilot of power switch 2	4
N	AC Neutral (switch 2)	5

Fig. A1: Bloc Diagram.

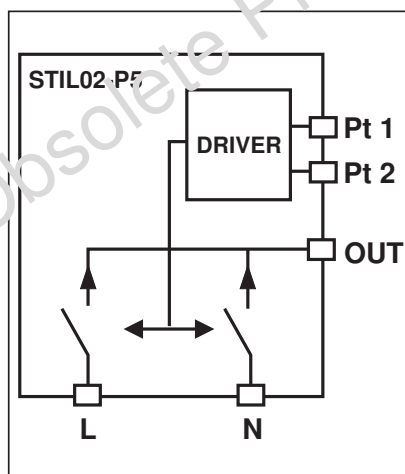
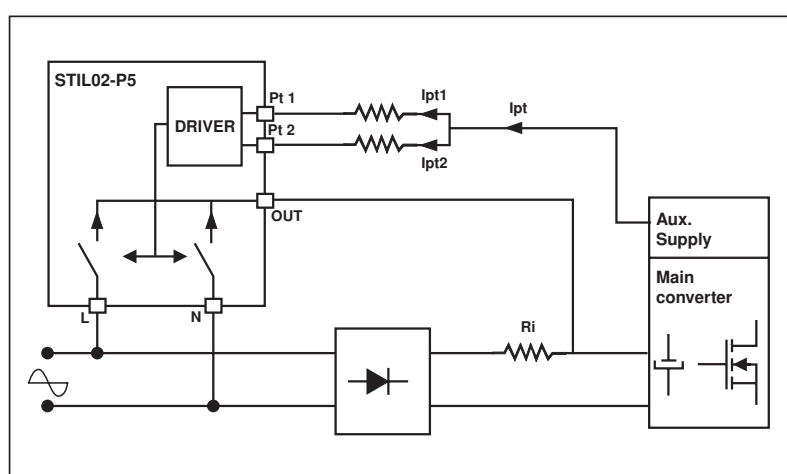

Fig. A2: Basic connection.



STIL02-P5

Functional Description

The **STIL02** is connected in parallel with the bridge diode and the inrush power resistor R_i (fig. A2). During start up, the two unidirectional **ASD™** power switches of the STIL02 are opened. The inrush current flows through the diodes of the bridge and the external inrush power resistor R_i . Since the main converter turns ON, the auxiliary power supply coupled with the main transformer, supplies the energy required to close the two power switches of the STIL02. At the normal state, the two bottom diodes of the bridge rectifier and the two unidirectional switches of the STIL02 rectify the AC line current.

When the STIL02 is used with a PFC boost converter, the inrush current circuit remains active after a short AC line dropout (see fig. A5). In that configuration, since the AC line disappears, the PFC controller and the auxiliary power supply of the STIL turns OFF. The two switches of the STIL are opened. The output bulk capacitor C_b is discharging and it is providing the energy to the main converter. When the AC line recovers, the two switches remain opened and recharging inrush current of the capacitor C_b is deviated and limited through the resistor R_i . When the capacitor is charged, the PFC turns ON again and the two switches of the STIL switch ON.

More details on the design and operation of the driver circuit of figure A5 can be found in the application note “**AN1600 - STIL: Inrush Current Limitation Device for Off-Line Power Converter**”.

ABSOLUTE MAXIMUM RATINGS (Limiting value)

Symbol	Parameter	Value	Unit
V_{Dout} V_{Rout}	Repetitive forward (V_{Dout}) and reverse (V_{Rout}) off-state voltage	T_j (min) to T_j (max)	700 V
$I_{out(AV)}$	Average on state current at the OUT terminal (180° conduction angle for the internal power switches)	$T_j = 150^\circ\text{C}$	2 A
$I_{out(RMS)}$	RMS on state current at the OUT terminal (180° conduction angle for the internal power switches)	$T_j = 150^\circ\text{C}$	2.2 A
I_{TSM}	Non repetitive surge peak on-state current (T_j initial = 25°C)	$t_p = 10\text{ms}$ sinusoidal	65 A
I^2t	I^2t value - rating for fusing	$t_p = 10\text{ms}$	21 A^2s
dl_{out}/dt	Critical rate of rise of on state current $I_{pt1} + I_{pt2} = 20\text{mA}$	$T_j = 25^\circ\text{C}$ $T_j = 150^\circ\text{C}$	100 - $\text{A}/\mu\text{s}$
T_{stg}	Storage temperature range		-40 to +150 $^\circ\text{C}$
T_j	Junction temperature range		0 to +150 $^\circ\text{C}$

THERMAL PARAMETERS

Symbol	Parameter	Value	Unit
$R_{th(j-c)}$	Junction to case	2	$^\circ\text{C}/\text{W}$
$R_{th(j-a)}$	Junction to ambient (minimum footprint)	60	

ELECTRICAL CHARACTERISTICS

Symbol	Parameter	Test conditions	Min.	Typ.	Max.	Unit	
I _{pt1} + I _{pt2}	Driver trigger current	V _{Dout} = 12V (DC) R _L = 30Ω t _p = 380μs	T _j = 0°C	12	20	mA	
			T _j = 25°C		10		
V _D (pt1) V _D (pt2)	Direct pilot trigger voltage	V _{Dout} = 12V (DC) R _L = 30Ω	T _j = 0°C	0.6	0.85	1	V
			T _j = 25°C		0.8	0.95	
			T _j = 150°C	0.2	0.45		
V _R (pt1) V _R (pt2)	Peak reverse driver voltage		T _j = 25°C	8		V	
dV _{Dout} /dt	Dynamic voltage rising	Linear slope up to V _{Dout} = 470V	T _j = 150°C	500		V/μs	
I _{Rout} (off)	Max reverse current without driver current	V _{Rout} = 700V I _{pt1} = I _{pt2} = open	T _j = 25°C		5	μA	
			T _j = 150°C		300	μA	
I _{Rout} (on)	Max reverse current with driver current	V _{Rout} = 400V I _{pt1} = I _{pt2} = 10mA	T _j = 150°C		300	μA	
V _{t0}	Threshold direct voltage for one power switch	I _{out(AV)} = 2A	T _j = 150°C	0.7	0.8	V	
R _d	Dynamic direct resistance for one power switch	I _{out(AV)} = 2A	T _j = 150°C	70	100	mΩ	
V _F	Maximum instantaneous direct forward voltage drop for one power switch	I _{out(AV)} = 2A	T _j = 150°C	0.9	1.1	V	

Power losses calculations

When the input current is sinusoidal, the conducted power losses can be calculated by using the following formula:

$$P = V_{T0} \cdot I_{out(av)} + R_d \frac{(I_{out(av)} \times \pi)^2}{8}$$

If the output average current is 2Amps, V_{T0} and R_d of the electrical characteristics table can be used. For different output current please refer to the application note **AN1600** that provides guidelines to estimate the correct values of V_{T0} and R_d.

LIGHTNING SURGE IMMUNITY (IEC61000-4-5)

During lightning surge transient voltage across the AC line, over current and over voltage stress are applied on all the components of the power supply. The STIL02 can sustain a maximum peak surge current of **500A as defined by the combine waveform generator (8/20μs waveform as shown in fig. A3 and A4).**

Special recommendations for the lightning surge immunity:

- 1 - Check that the **maximum peak surge current** in the STIL stays below the limit specified above.
- 2 - Check that **no over voltages are applied** on the STIL and the bridge diode.
- 3 - In order to reduce the dynamic current stress (dI_{out}/dt) through the structure of the STIL02, it is recommended to connect a differential mode choke coil in front of the STIL and the bridge diode.

More details and design guidelines are provided in the application note "**AN1600 - STIL: Inrush Current Limitation Device for Off-Line Power Converter**".

Fig. A3: Surge test condition.

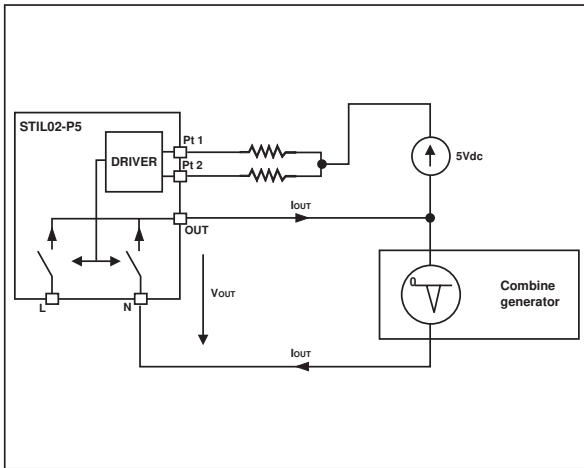

Fig. A4: Surge current waveform.

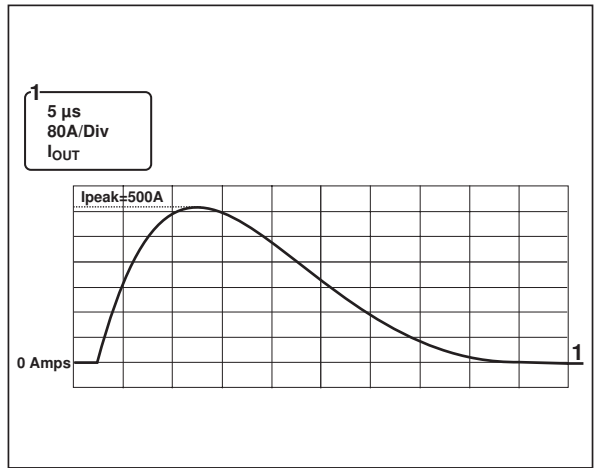

Fig. A5: Basic connection with a PFC Boost preregulator.

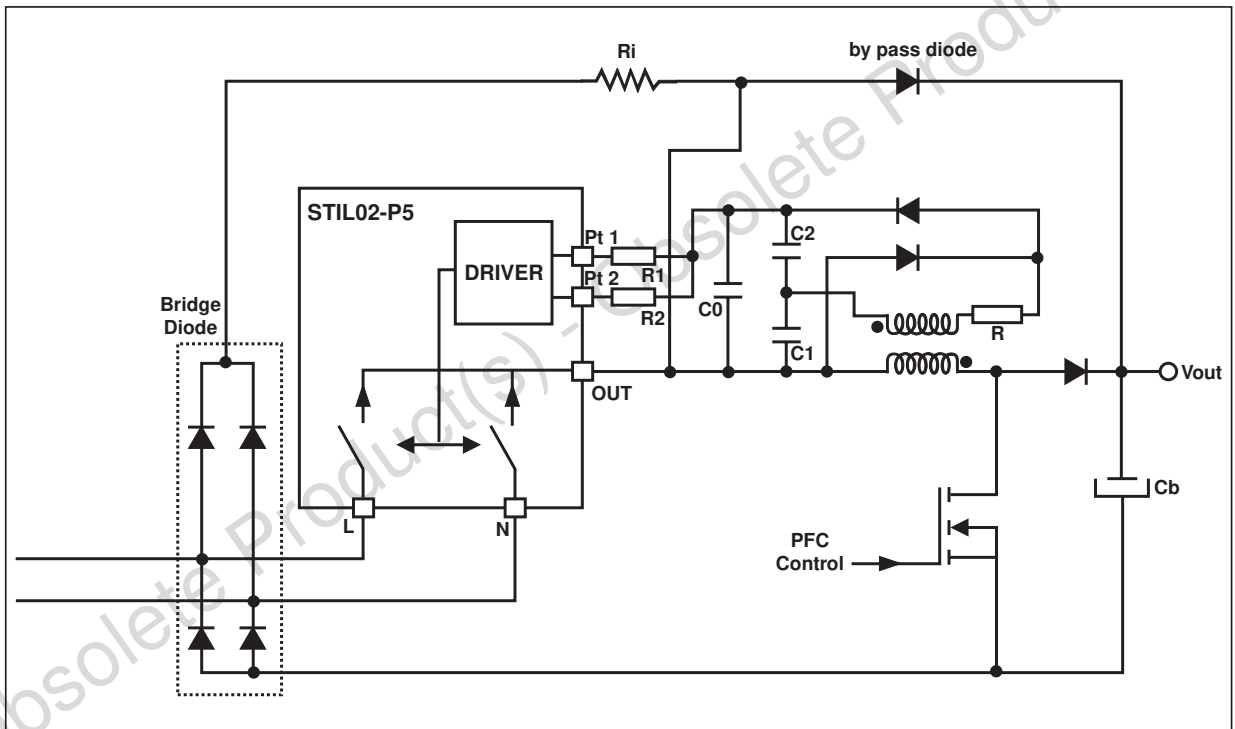

Fig. 1-1: Non repetitive surge peak on-state current (sinusoidal pulse) and corresponding value of I^2t .

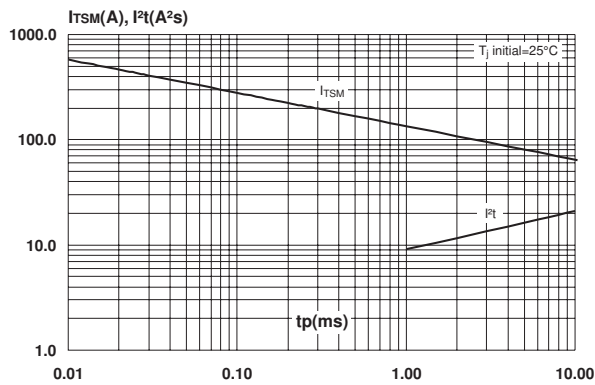

Fig. 1-2: Non repetitive surge peak on-state current (sinusoidal pulse) and corresponding value of I^2t .

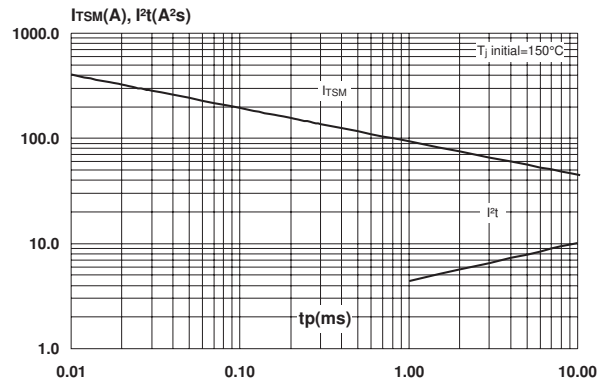

Fig. 2: Relative variation of driver trigger current versus junction temperature (typical values).

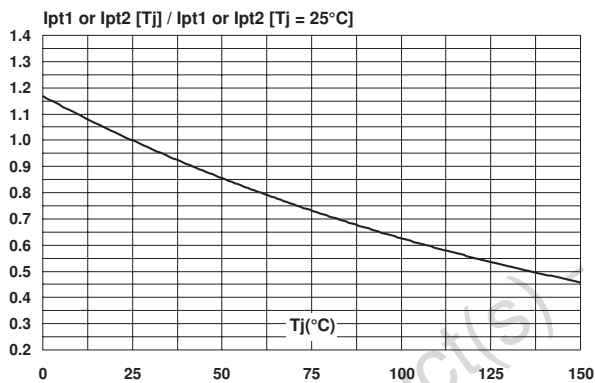

Fig. 3: Relative variation of direct pilot voltage versus junction temperature (typical values).

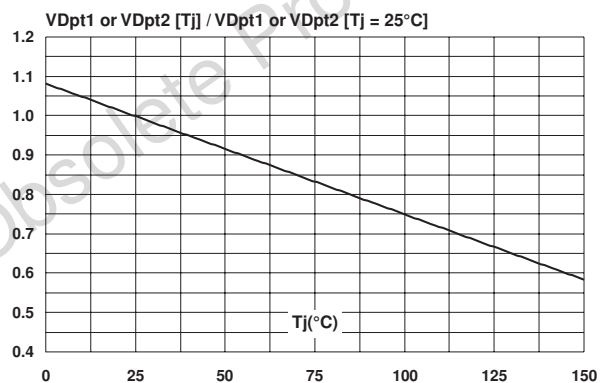

Fig. 4: Relative variation of thermal impedance junction to case versus pulse duration.

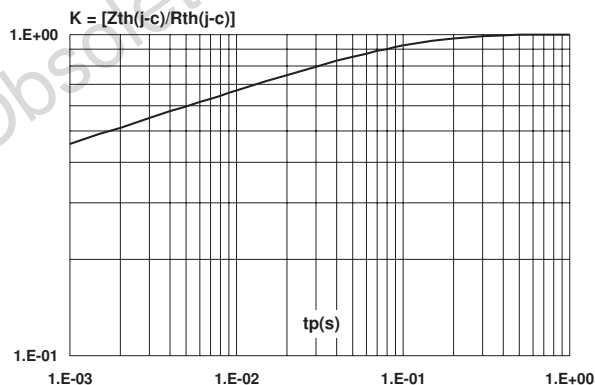

Fig. 5-1: Reverse current versus junction temperature without driver current (typical values).

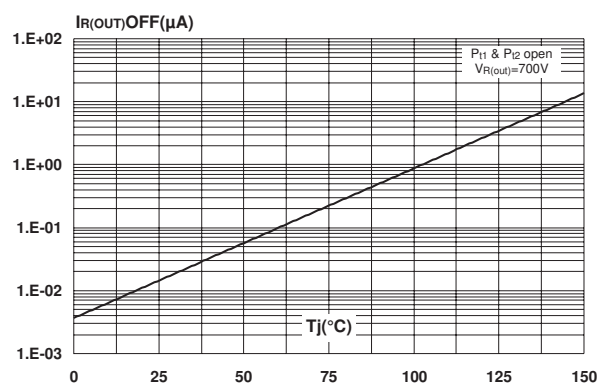

Fig. 5-2: Reverse current versus junction temperature with driver current (typical values).

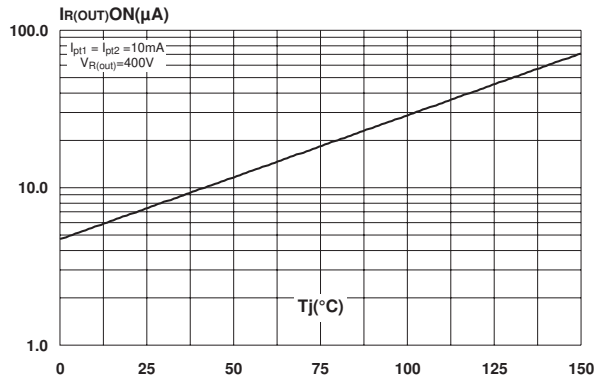

Fig. 6: Forward voltage drop for one power switch versus junction temperature at the peak forward current (typical values).

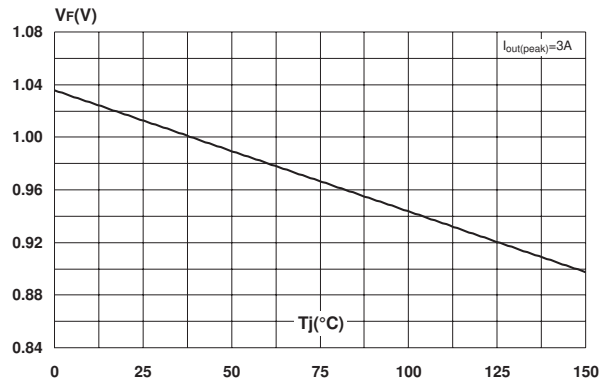

Fig. 7-1: Peak forward voltage drop versus peak forward output current for one power switch at $T_j=25^{\circ}C$ (typical and maximal values).

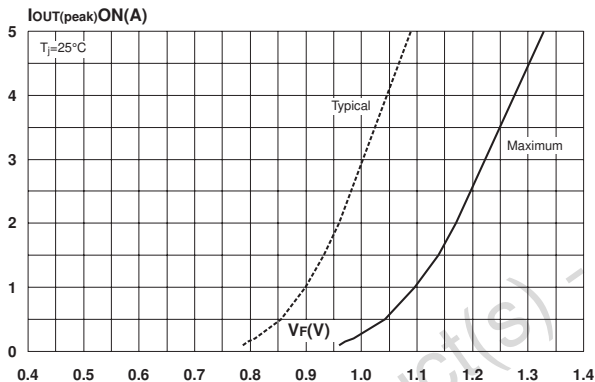

Fig. 7-2: Peak forward voltage drop versus peak forward output current for one power switch at $T_j=150^{\circ}C$ (typical and maximum values).

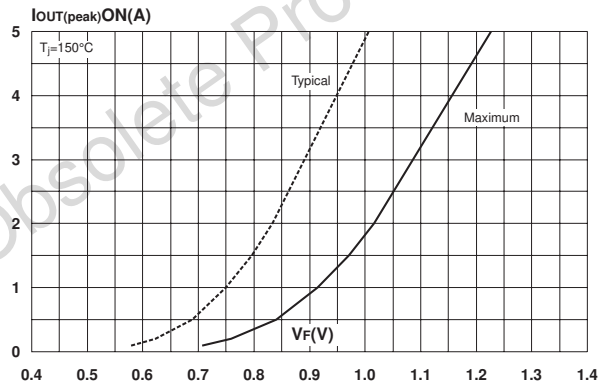
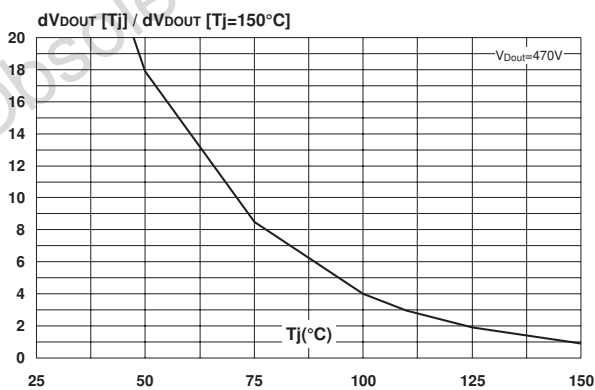
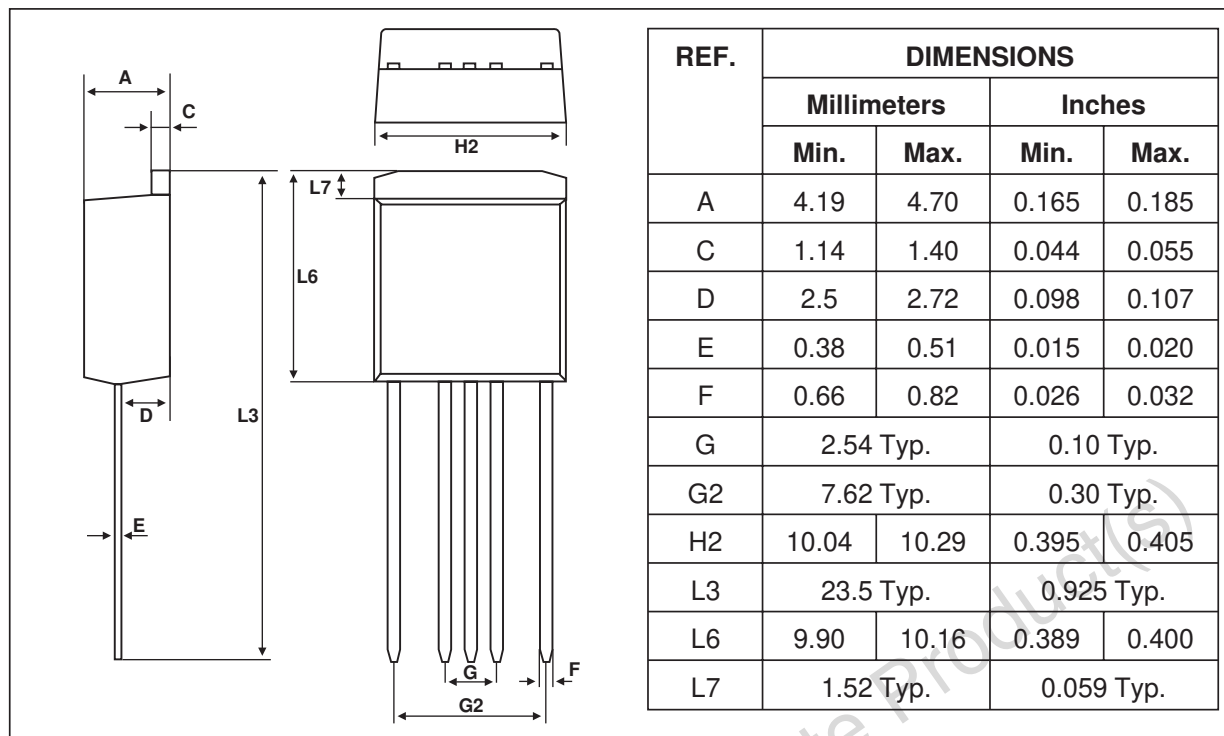

Fig. 8: Relative variation of dV/dt immunity versus junction temperature (typical values).



PACKAGE MECHANICAL DATA

PENTAWATT HV2 (in line)



Order code	Marking	Package	Weight	Delivery mode	Base qty
STIL02-P5	STIL02	PENTAWATT HV2 (in line)	1.9 g.	Tube	50

Information furnished is believed to be accurate and reliable. However, STMicroelectronics assumes no responsibility for the consequences of use of such information nor for any infringement of patents or other rights of third parties which may result from its use. No license is granted by implication or otherwise under any patent or patent rights of STMicroelectronics. Specifications mentioned in this publication are subject to change without notice. This publication supersedes and replaces all information previously supplied. STMicroelectronics products are not authorized for use as critical components in life support devices or systems without express written approval of STMicroelectronics.

The ST logo is a registered trademark of STMicroelectronics

© 2002 STMicroelectronics - Printed in Italy - All rights reserved.

STMicroelectronics GROUP OF COMPANIES

Australia - Brazil - Canada - China - Finland - France - Germany
 Hong Kong - India - Israel - Italy - Japan - Malaysia - Malta - Morocco - Singapore
 Spain - Sweden - Switzerland - United Kingdom - United States.

<http://www.st.com>