



Chipsmall Limited consists of a professional team with an average of over 10 year of expertise in the distribution of electronic components. Based in Hongkong, we have already established firm and mutual-benefit business relationships with customers from,Europe,America and south Asia,supplying obsolete and hard-to-find components to meet their specific needs.

With the principle of “Quality Parts,Customers Priority,Honest Operation,and Considerate Service”,our business mainly focus on the distribution of electronic components. Line cards we deal with include Microchip,ALPS,ROHM,Xilinx,Pulse,ON,Everlight and Freescale. Main products comprise IC,Modules,Potentiometer,IC Socket,Relay,Connector.Our parts cover such applications as commercial,industrial, and automotives areas.

We are looking forward to setting up business relationship with you and hope to provide you with the best service and solution. Let us make a better world for our industry!



Contact us

Tel: +86-755-8981 8866 Fax: +86-755-8427 6832

Email & Skype: info@chipsmall.com Web: www.chipsmall.com

Address: A1208, Overseas Decoration Building, #122 Zhenhua RD., Futian, Shenzhen, China



SLLIMM™-nano small low-loss intelligent molded module IPM, 3-phase inverter, 1 A, 3.6 Ω max., 500 V MOSFET

Datasheet - production data

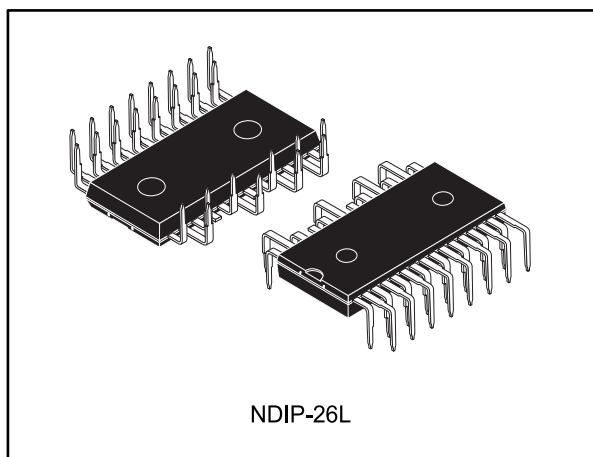

Features

- IPM 1 A, 500 V, $R_{DS(on)} = 3.6 \Omega$, 3-phase MOSFET inverter bridge including control ICs for gate driving
- Optimized for low electromagnetic interference
- 3.3 V, 5 V, 15 V CMOS/TTL input comparators with hysteresis and pull-down/pull-up resistors
- Undervoltage lockout
- Internal bootstrap diode
- Interlocking function
- Smart shutdown function
- Comparator for fault protection against overtemperature and overcurrent
- Op-amp for advanced current sensing
- Optimized pinout for easy board layout
- NTC for temperature control (UL 1434 CA 2 and 4)
- Up to ± 2 kV ESD protection (HBM $C = 100$ pF, $R = 1.5$ k Ω)

Applications

- 3-phase inverters for small power motor drives
- Dish washers, refrigerator compressors, heating systems, air-conditioning fans, draining and recirculation pumps

Description

This SLLIMM (small low-loss intelligent molded module) nano provides a compact, high performance AC motor drive in a simple, rugged design. It is composed of six MOSFETs and three half-bridge HVICs for gate driving, providing low electromagnetic interference (EMI) characteristics with optimized switching speed. The package is optimized for thermal performance and compactness in built-in motor applications, or other low power applications where assembly space is limited. This IPM includes an operational amplifier, completely uncommitted, and a comparator that can be used to design a fast and efficient protection circuit. SLLIMM™ is a trademark of STMicroelectronics.

Table 1: Device summary

Order code	Marking	Package	Packing
STIPN1M50T-H	IPN1M50T-H	NDIP-26L	Tube

Contents

1	Internal schematic diagram and pin configuration	3
2	Electrical ratings	6
2.1	Absolute maximum ratings	6
2.2	Thermal data	6
3	Electrical characteristics	7
3.1	Inverter part	7
3.2	Control part	9
3.2.1	NTC thermistor	12
3.3	Waveform definitions	14
4	Smart shutdown function	15
5	Application circuit example	17
5.1	Guidelines	18
6	Package information	19
6.1	NDIP-26L package information	20
6.2	NDIP-26L packing information	22
7	Revision history	23

1 Internal schematic diagram and pin configuration

Figure 1: Internal schematic diagram

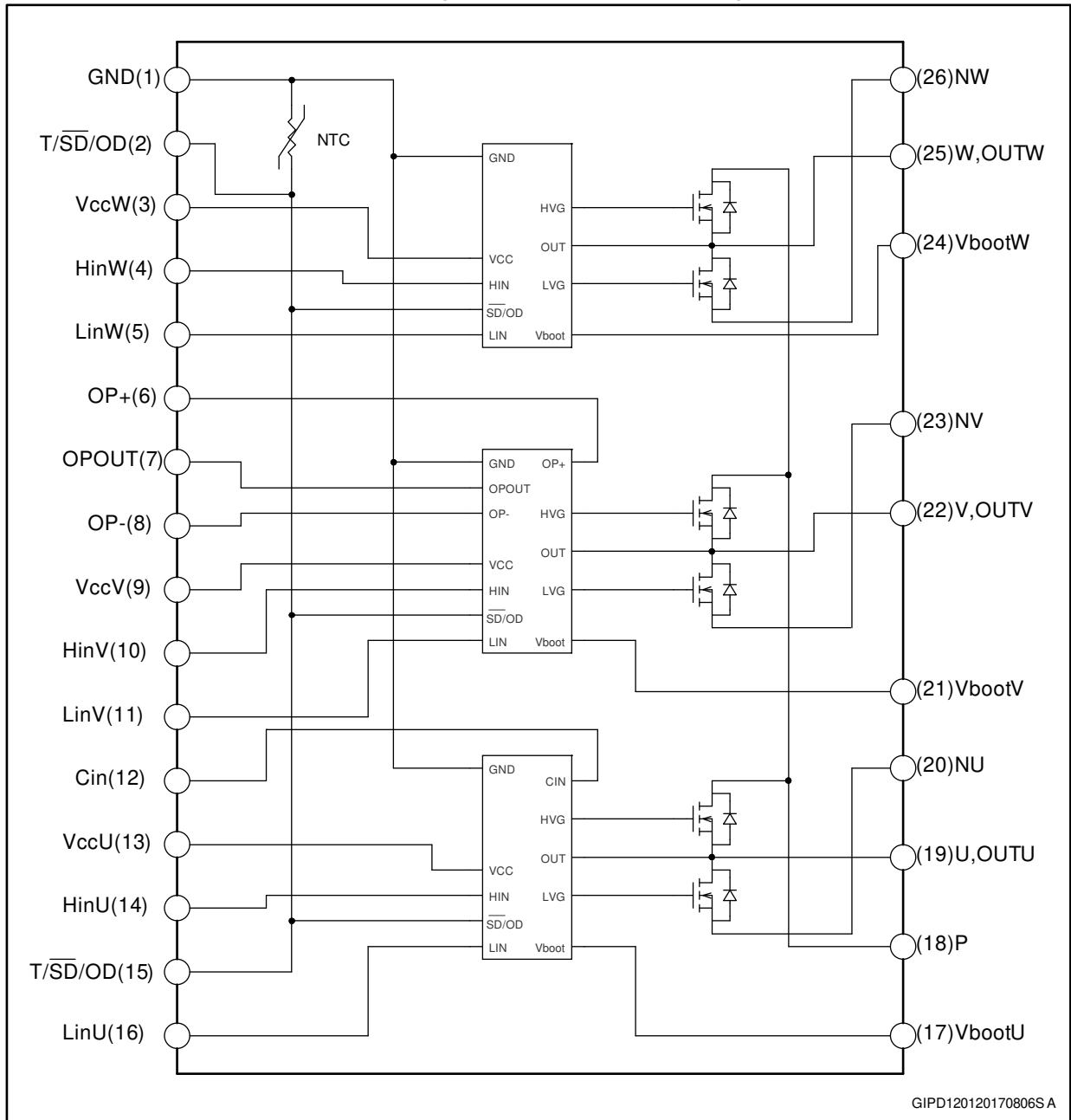
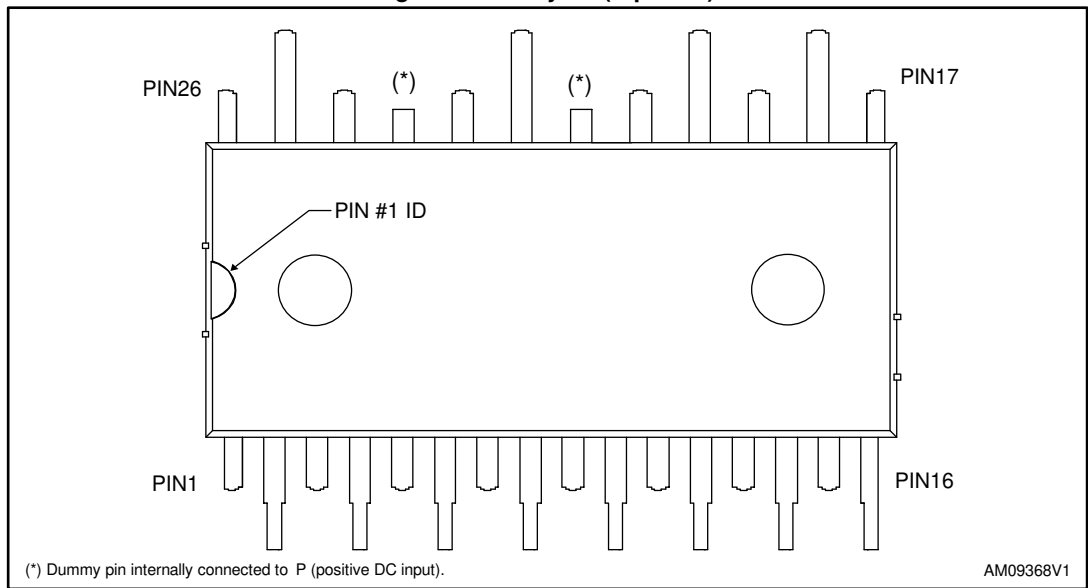

Table 2: Pin description

Pin	Symbol	Description
1	GND	Ground
2	T/ \overline{SD} /OD	NTC thermistor terminal / shutdown logic input (active low) / open-drain (comparator output)
3	V _{CC} W	Low voltage power supply W phase
4	HIN W	High-side logic input for W phase
5	LIN W	Low-side logic input for W phase
6	OP+	Op-amp non inverting input
7	OP _{OUT}	Op-amp output
8	OP-	Op-amp inverting input
9	V _{CC} V	Low voltage power supply V phase
10	HIN V	High-side logic input for V phase
11	LIN V	Low-side logic input for V phase
12	CIN	Comparator input
13	V _{CC} U	Low voltage power supply for U phase
14	HIN U	High-side logic input for U phase
15	T/ \overline{SD} /OD	NTC thermistor terminal / shutdown logic input (active low) / open-drain (comparator output)
16	LIN U	Low-side logic input for U phase
17	V _{BOOT} U	Bootstrap voltage for U phase
18	P	Positive DC input
19	U, OUT _U	U phase output
20	N _U	Negative DC input for U phase
21	V _{BOOT} V	Bootstrap voltage for V phase
22	V, OUT _V	V phase output
23	N _V	Negative DC input for V phase
24	V _{BOOT} W	Bootstrap voltage for W phase
25	W, OUT _W	W phase output
26	N _W	Negative DC input for W phase

Figure 2: Pin layout (top view)



2 Electrical ratings

2.1 Absolute maximum ratings

Table 3: Inverter part

Symbol	Parameter	Value	Unit
V_{DSS}	MOSFET blocking voltage (or drain-source voltage) for each MOSFET ($V_{IN}^{(1)} = 0$)	500	V
$\pm I_D$	Continuous current each MOSFET	1	A
$\pm I_{DP}^{(2)}$	Peak drain current each MOSFET (less than 1 ms)	2	A
P_{TOT}	Each MOSFET total dissipation at $T_C = 25\text{ °C}$	8.3	W

Notes:

⁽¹⁾Applied among HINi, LINi and GND for i = U, V, W.

⁽²⁾Pulse width limited by max. junction temperature.

Table 4: Control part

Symbol	Parameter	Min.	Max.	Unit
V_{OUT}	Output voltage applied among OUT_U , OUT_V , OUT_W - GND	$V_{boot} - 21$	$V_{boot} + 0.3$	V
V_{CC}	Low voltage power supply	- 0.3	21	V
V_{CIN}	Comparator input voltage	- 0.3	$V_{CC} + 0.3$	V
V_{op+}	Op-amp non-inverting input	- 0.3	$V_{CC} + 0.3$	V
V_{op-}	Op-amp inverting input	- 0.3	$V_{CC} + 0.3$	V
V_{boot}	Bootstrap voltage	- 0.3	620	V
V_{IN}	Logic input voltage applied among HIN, LIN and GND	- 0.3	15	V
$V_{T/\overline{SD}/OD}$	Open-drain voltage	- 0.3	15	V
$\Delta V_{OUT}/dT$	Allowed output slew rate		50	V/ns

Table 5: Total system

Symbol	Parameter	Value	Unit
V_{ISO}	Isolation withstand voltage applied between each pin and heatsink plate (AC voltage, $t = 60\text{ s}$)	1000	V
T_j	Power chip operating junction temperature range	-40 to 150	°C
T_C	Module case operation temperature range	-40 to 125	°C

2.2 Thermal data

Table 6: Thermal data

Symbol	Parameter	Value	Unit
$R_{th(j-c)}$	Thermal resistance junction-case	15	°C/W

3 Electrical characteristics

$T_J = 25\text{ }^\circ\text{C}$ unless otherwise specified.

3.1 Inverter part

Table 7: Static

Symbol	Parameter	Test conditions	Min.	Typ.	Max.	Unit
I_{DSS}	Zero-gate voltage drain current	$V_{DS} = 500\text{ V}$, $V_{CC} = 15\text{ V}$; $V_{boot} = 15\text{ V}$			1	mA
$V_{(BR)DSS}$	Drain-source breakdown voltage	$V_{CC} = V_{boot} = 15\text{ V}$, $V_{IN}^{(1)} = 0\text{ V}$, $I_D = 1\text{ mA}$	500			V
$R_{DS(on)}$	Static drain source turn-on resistance	$V_{CC} = V_{boot} = 15\text{ V}$, $V_{IN}^{(1)} = 0 - 5\text{ V}$, $I_D = 0.5\text{ A}$		3.2	3.6	Ω
V_{SD}	Drain-source diode forward voltage	$V_{IN}^{(1)} = 0$ "logic state", $I_D = 1\text{ A}$		0.9	1.6	V

Notes:

⁽¹⁾Applied among HINx, LINx and GND for x=U,V,W.

Table 8: Inductive load switching time and energy

Symbol	Parameter	Test conditions	Min.	Typ.	Max.	Unit
$t_{on}^{(1)}$	Turn-on time	$V_{DD} = 300\text{ V}$, $V_{CC} = V_{boot} = 15\text{ V}$, $V_{IN}^{(2)} = 0 - 5\text{ V}$, $I_C = 0.5\text{ A}$ (see Figure 4: "Switching time definition")	-	226	-	ns
$t_{c(on)}^{(1)}$	Crossover time (on)		-	130	-	
$t_{off}^{(1)}$	Turn-off time		-	248	-	
$t_{c(off)}^{(1)}$	Crossover time (off)		-	56	-	
t_{rr}	Reverse recovery time		-	155	-	
E_{on}	Turn-on switching energy		-	25	-	μJ
E_{off}	Turn-off switching energy		-	3.8	-	

Notes:

⁽¹⁾ t_{ON} and t_{OFF} include the propagation delay time of the internal drive. $t_{c(ON)}$ and $t_{c(OFF)}$ are the switching time of MOSFET itself under the internally given gate driving conditions.

⁽²⁾Applied among HINx, LINx and GND for x=U,V,W.

Figure 3: Switching time test circuit

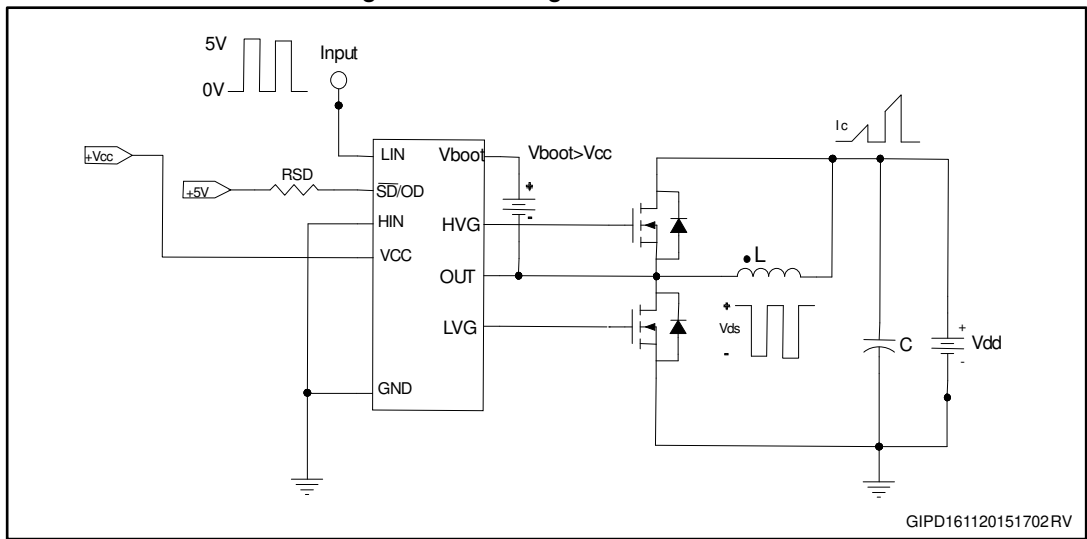

Figure 4: Switching time definition

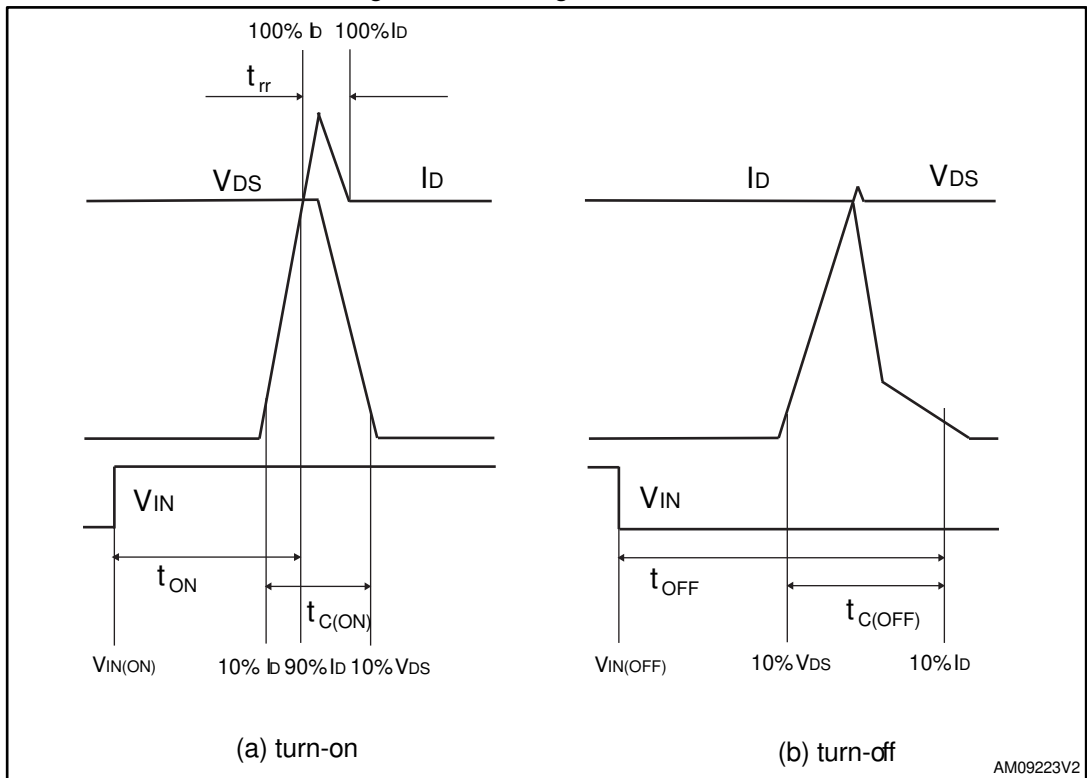

Figure 4: "Switching time definition" refers to HIN, LIN inputs (active high).

3.2 Control part

Table 9: Low voltage power supply ($V_{CC} = 15\text{ V}$ unless otherwise specified)

Symbol	Parameter	Test conditions	Min.	Typ.	Max.	Unit
V_{CC_hys}	V_{CC} UV hysteresis		1.2	1.5	1.8	V
V_{CC_thON}	V_{CC} UV turn ON threshold		11.5	12	12.5	V
V_{CC_thOFF}	V_{CC} UV turn OFF threshold		10	10.5	11	V
I_{qccu}	Undervoltage quiescent supply current	$V_{CC} = 10\text{ V}$, $T/\overline{SD}/OD = 5\text{ V}$; $LIN = 0\text{ V}$; $HIN = 0$, $CIN = 0$			150	μA
I_{qcc}	Quiescent current	$V_{CC} = 15\text{ V}$, $T/\overline{SD}/OD = 5\text{ V}$; $LIN = 0\text{ V}$; $HIN = 0$, $CIN = 0$			1	mA
V_{ref}	Internal comparator (CIN) reference voltage		0.5	0.54	0.58	V

Table 10: Bootstrapped voltage ($V_{CC} = 15\text{ V}$ unless otherwise specified)

Symbol	Parameter	Test conditions	Min.	Typ.	Max.	Unit
V_{BS_hys}	V_{BS} UV hysteresis		1.2	1.5	1.8	V
V_{BS_thON}	V_{BS} UV turn-ON threshold		11.1	11.5	12.1	V
V_{BS_thOFF}	V_{BS} UV turn-OFF threshold		9.8	10	10.6	V
I_{qBSU}	Undervoltage V_{BS} quiescent current	$V_{BS} < 9\text{ V}$, $T/\overline{SD}/OD = 5\text{ V}$; $LIN = 0\text{ V}$ and $HIN = 5\text{ V}$; $CIN = 0$		70	110	μA
I_{qBS}	V_{BS} quiescent current	$V_{BS} = 15\text{ V}$, $T/\overline{SD}/OD = 5\text{ V}$; $LIN = 0\text{ V}$ and $HIN = 5\text{ V}$; $CIN = 0$		200	300	μA
$R_{DS(on)}$	Bootstrap driver on-resistance	LVG ON		120		Ω

Table 11: Logic inputs (V_{CC} = 15 V unless otherwise specified)

Symbol	Parameter	Test conditions	Min.	Typ.	Max.	Unit
V _{il}	Low logic level voltage				0.8	V
V _{ih}	High logic level voltage		2.25			V
I _{HINh}	HIN logic "1" input bias current	HIN = 15 V	20	40	100	μA
I _{HINl}	HIN logic "0" input bias current	HIN = 0 V			1	μA
I _{LINh}	LIN logic "1" input bias current	LIN = 15 V	20	40	100	μA
I _{LINl}	LIN logic "0" input bias current	LIN = 0 V			1	μA
I _{SDh}	\overline{SD} logic "0" input bias current	\overline{SD} = 15 V	220	295	370	μA
I _{SDl}	\overline{SD} logic "1" input bias current	\overline{SD} = 0 V			3	μA
Dt	Dead time	see Figure 9: "Dead time and interlocking waveform definitions"		180		ns

Table 12: Op-amp characteristics (V_{CC} = 15 V unless otherwise specified)

Symbol	Parameter	Test conditions	Min.	Typ.	Max.	Unit
V _{io}	Input offset voltage	V _{ic} = 0 V, V _o = 7.5 V			6	mV
I _{io}	Input offset current	V _{ic} = 0 V, V _o = 7.5 V		4	40	nA
I _{ib}	Input bias current ⁽¹⁾			100	200	nA
V _{OL}	Low level output voltage	R _L = 10 kΩ to V _{CC}		75	150	mV
V _{OH}	High level output voltage	R _L = 10 kΩ to GND	14	14.7		V
I _o	Output short-circuit current	Source, V _{id} = +1 V; V _o = 0 V	16	30		mA
		Sink, V _{id} = -1 V; V _o = V _{CC}	50	80		mA
SR	Slew rate	V _i = 1 - 4 V; C _L = 100 pF; unity gain	2.5	3.8		V/μs
GBWP	Gain bandwidth product	V _o = 7.5 V	8	12		MHz
A _{vd}	Large signal voltage gain	R _L = 2 kΩ	70	85		dB
SVR	Supply voltage rejection ratio	vs. V _{CC}	60	75		dB
CMRR	Common mode rejection ratio		55	70		dB

Notes:

⁽¹⁾The direction of input current is out of the IC.

Table 13: Sense comparator characteristics ($V_{CC} = 15\text{ V}$ unless otherwise specified)

Symbol	Parameter	Test conditions	Min.	Typ.	Max.	Unit
I_{ib}	Input bias current	$V_{CIN} = 1\text{ V}$			3	μA
V_{od}	Open-drain low level output voltage	$I_{od} = 3\text{ mA}$			0.5	V
R_{ON_OD}	Open-drain low level output resistance	$I_{od} = 3\text{ mA}$		166		Ω
R_{PD_SD}	\overline{SD} pull-down resistor ⁽¹⁾			125		$\text{k}\Omega$
t_{d_comp}	Comparator delay	T/ \overline{SD} /OD pulled to 5 V through 100 $\text{k}\Omega$ resistor		90	130	ns
SR	Slew rate	$C_L = 180\text{ pF}$; $R_{pu} = 5\text{ k}\Omega$		60		V/ μs
t_{sd}	Shutdown to high / low-side driver propagation delay	$V_{OUT} = 0$, $V_{boot} = V_{CC}$, $V_{IN} = 0$ to 3.3 V	50	125	200	ns
t_{isd}	Comparator triggering to high / low-side driver turn-off propagation delay	Measured applying a voltage step from 0 V to 3.3 V to pin CIN	50	200	250	

Notes:

⁽¹⁾Equivalent values as a result of the resistances of three drivers in parallel.

Table 14: Truth table

Condition	Logic input (V_i)			Output	
	T/ \overline{SD} /OD	LIN	HIN	LVG	HVG
Shutdown enable half-bridge tri-state	L	X ⁽¹⁾	X ⁽¹⁾	L	L
Interlocking half-bridge tri-state	H	H	H	L	L
0 "logic state" half-bridge tri-state	H	L	L	L	L
1 "logic state" low-side direct driving	H	H	L	H	L
1 "logic state" high-side direct driving	H	L	H	L	H

Notes:

⁽¹⁾X: don't care.

3.2.1 NTC thermistor

Figure 5: Internal structure of \overline{SD} and NTC

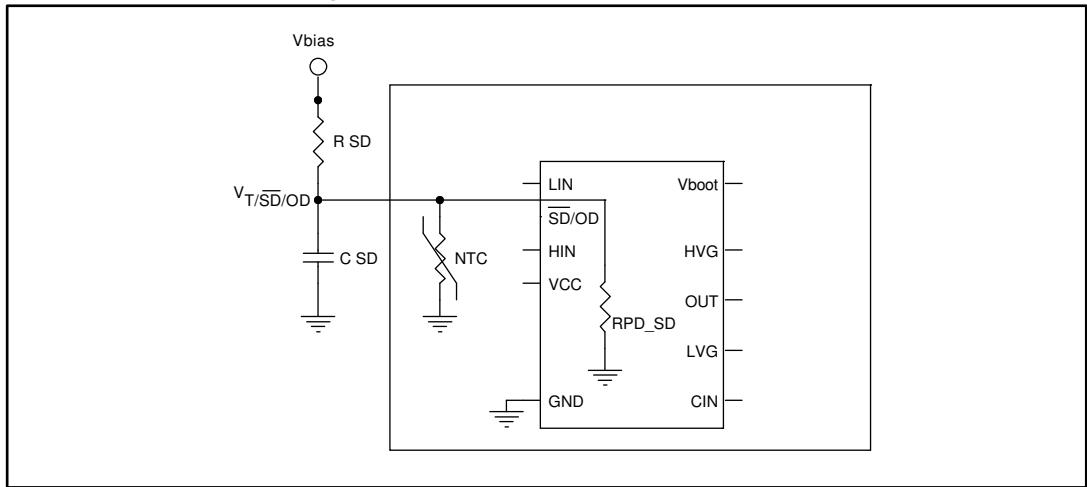

RPD_SD: equivalent value as result of resistances of three drivers in parallel.

Figure 6: Equivalent resistance (NTC//RPD_SD)

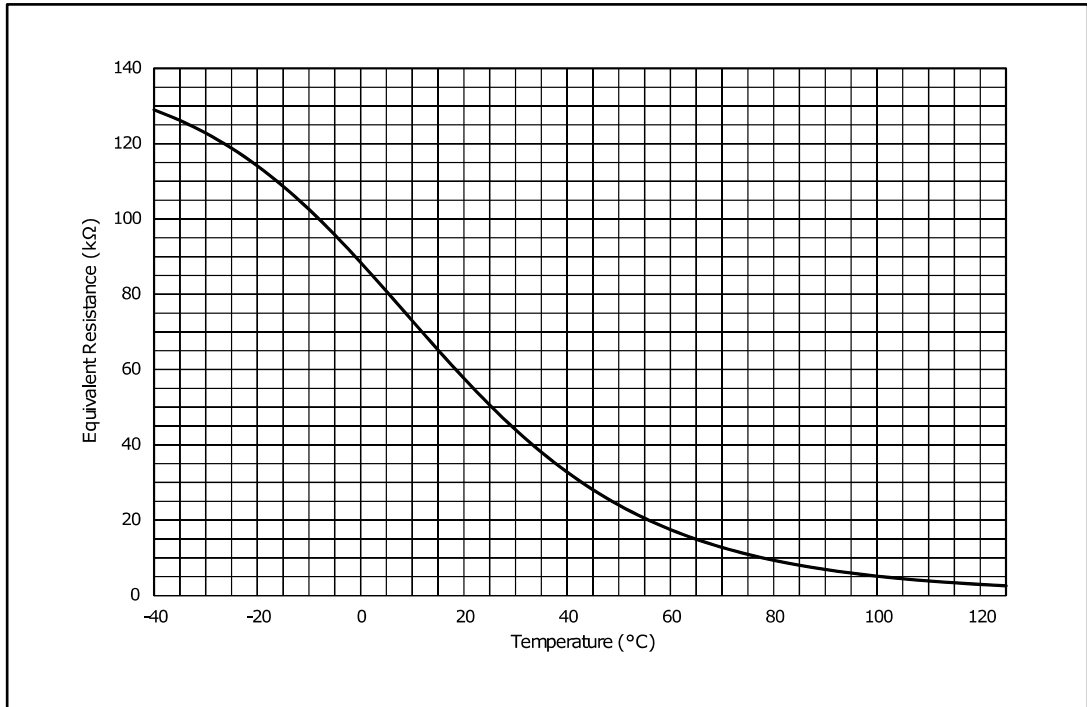

Figure 7: Equivalent resistance (NTC//RPD_SD) zoom

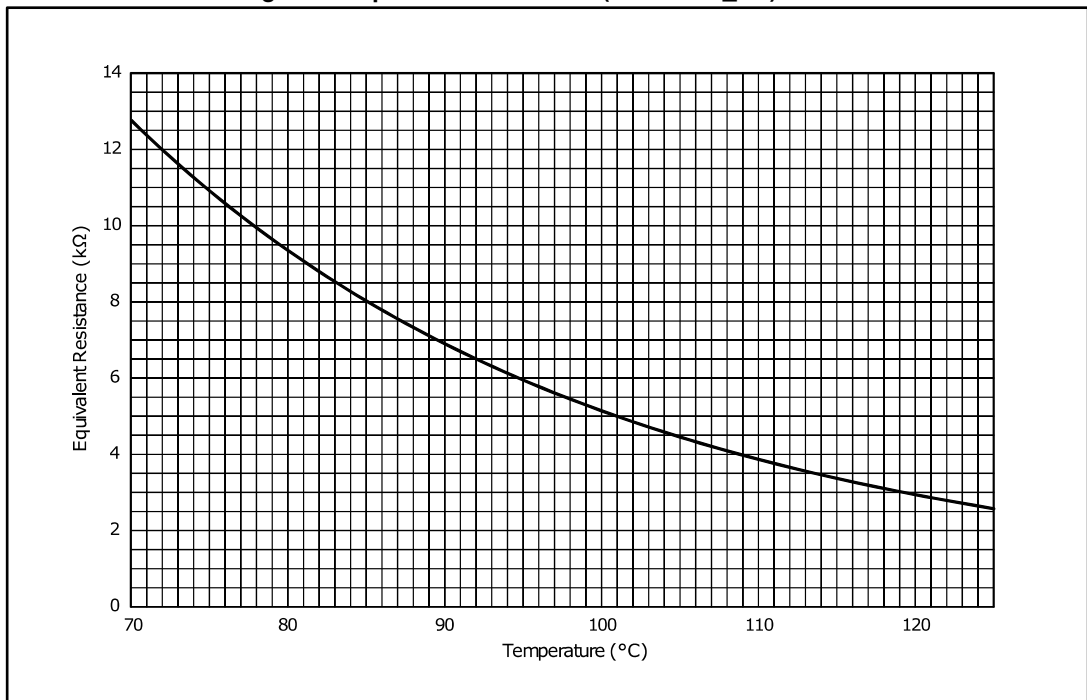
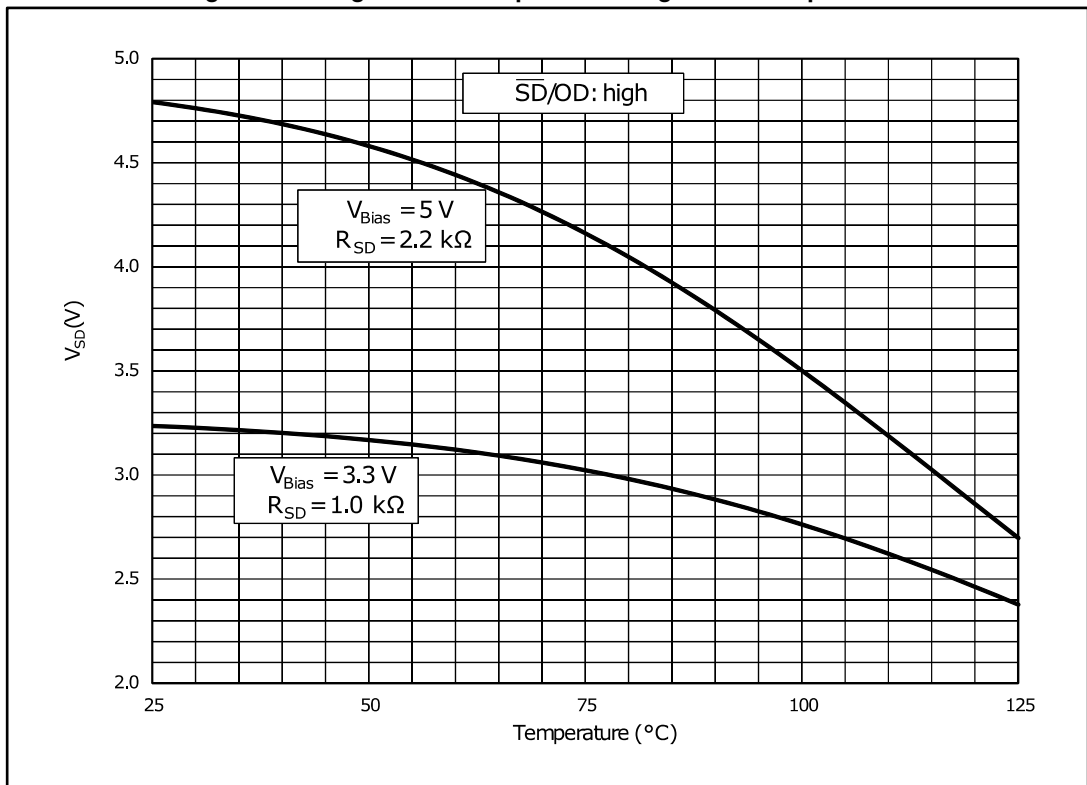
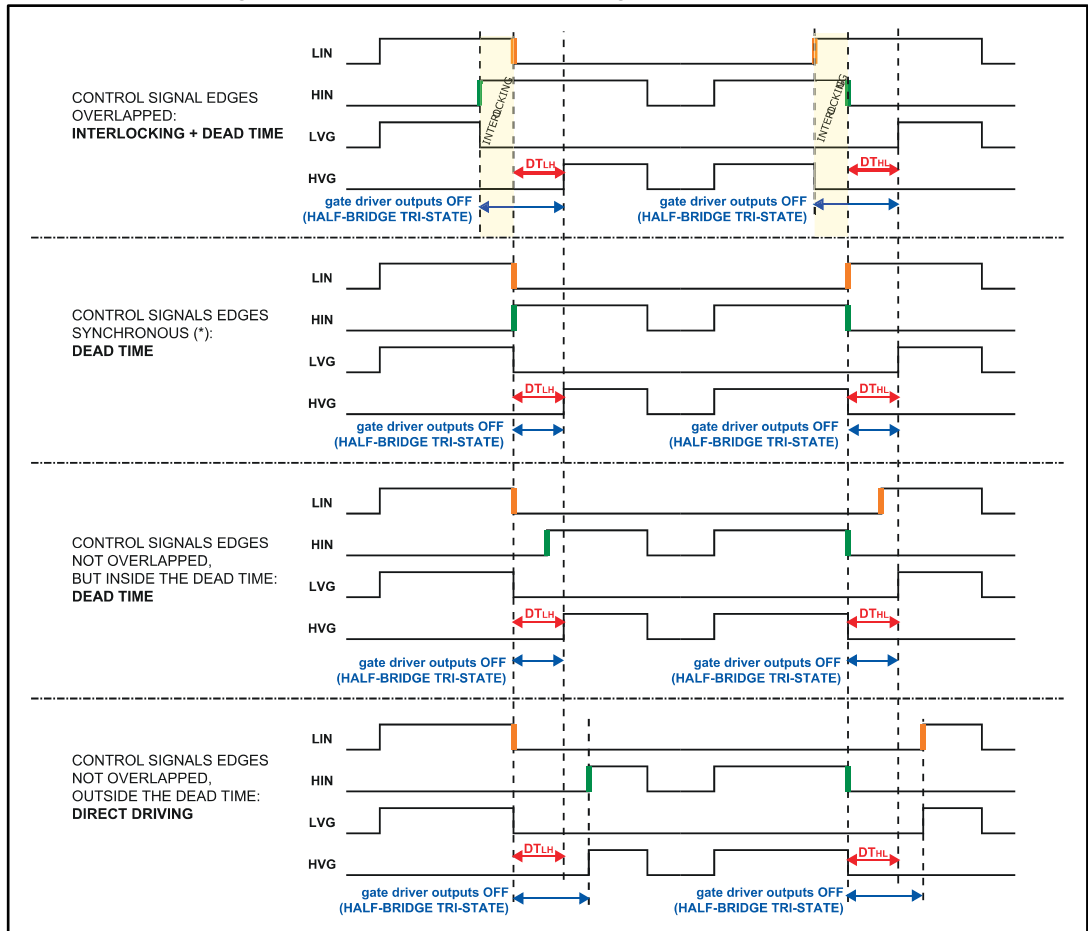

Figure 8: Voltage of T/SD/OD pin according to NTC temperature



3.3 Waveform definitions

Figure 9: Dead time and interlocking waveform definitions



4 Smart shutdown function

The device integrates a comparator for fault sensing purposes. The comparator has an internal voltage reference V_{REF} connected to the inverting input, while the non-inverting input on pin (CIN) can be connected to an external shunt resistor for simple overcurrent protection.

When the comparator triggers, the device is set to the shutdown state and both of its outputs are set to the low level, causing the half-bridge to enter a tri-state.

In common overcurrent protection architectures, the comparator output is usually connected to the shutdown input through an RC network so to provide a monostable circuit which implements a protection time following to a fault condition.

Our smart shutdown architecture immediately turns off the output gate driver in case of overcurrent through a preferential path for the fault signal which directly switches off the outputs. The time delay between the fault and output shutdown no longer depends on the RC values of the external network connected to the shutdown pin. At the same time, the DMOS connected to the open-drain output (pin T/ \overline{SD} /OD) is turned on by the internal logic, which holds it on until the shutdown voltage is lower than the minimum value of logic input threshold.

Besides, the smart shutdown function allows the real disable time to be increased while the constant time of the external RC network remains as it is.

An NTC thermistor for temperature monitoring is internally connected in parallel to the \overline{SD} pin. To avoid undesired shutdown, keep the voltage $V_{T/\overline{SD}/OD}$ higher than the high-level logic threshold by setting the pull-up resistor $R_{\overline{SD}}$ to 1 k Ω or 2.2 k Ω for 3.3 V or 5 V MCU power supplies, respectively.

Figure 10: Smart shutdown timing waveforms

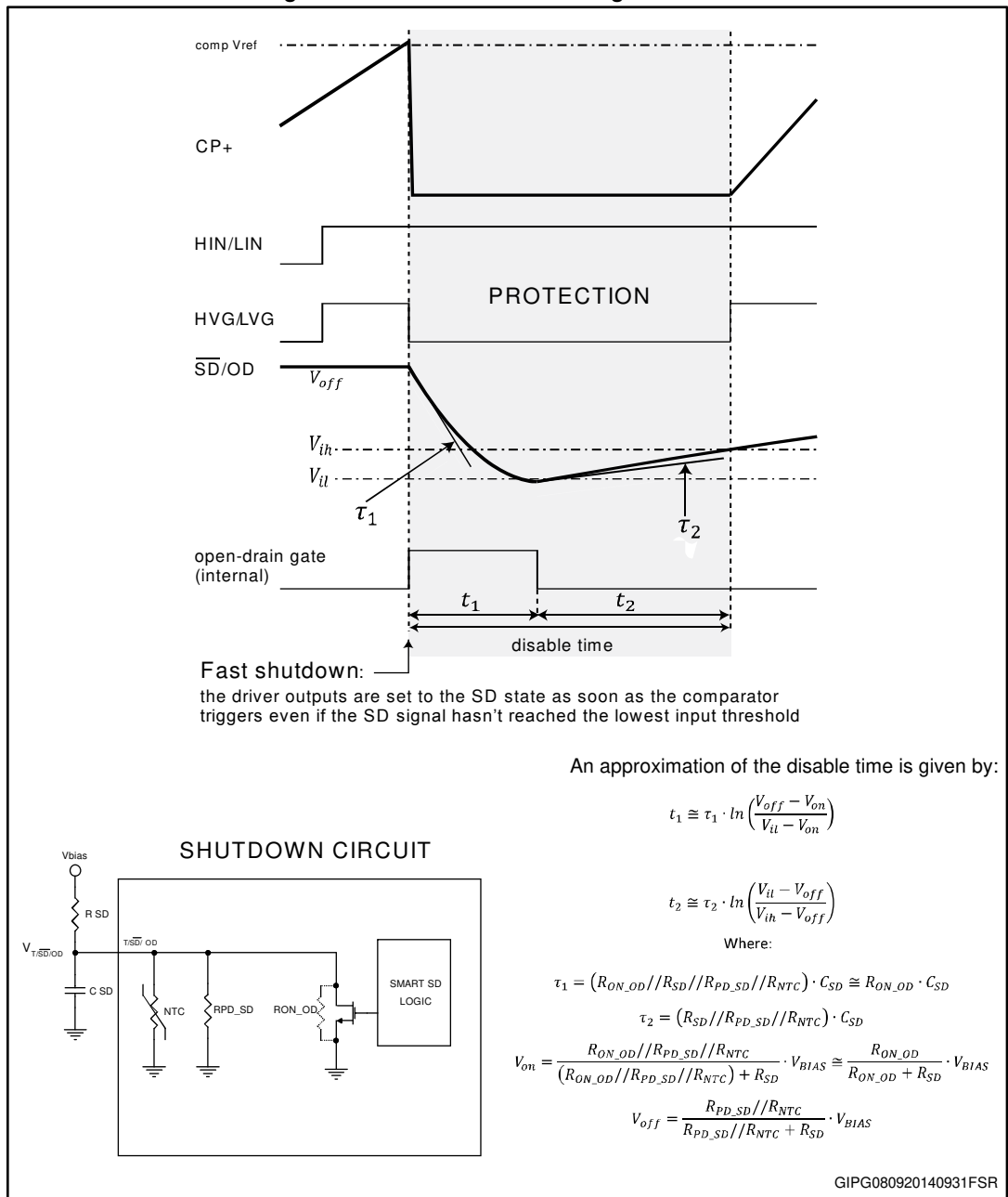

Please refer to [Table 13: "Sense comparator characteristics \(VCC = 15 V unless otherwise specified\)"](#) for internal propagation delay time details.

5 Application circuit example

Figure 11: Application circuit example

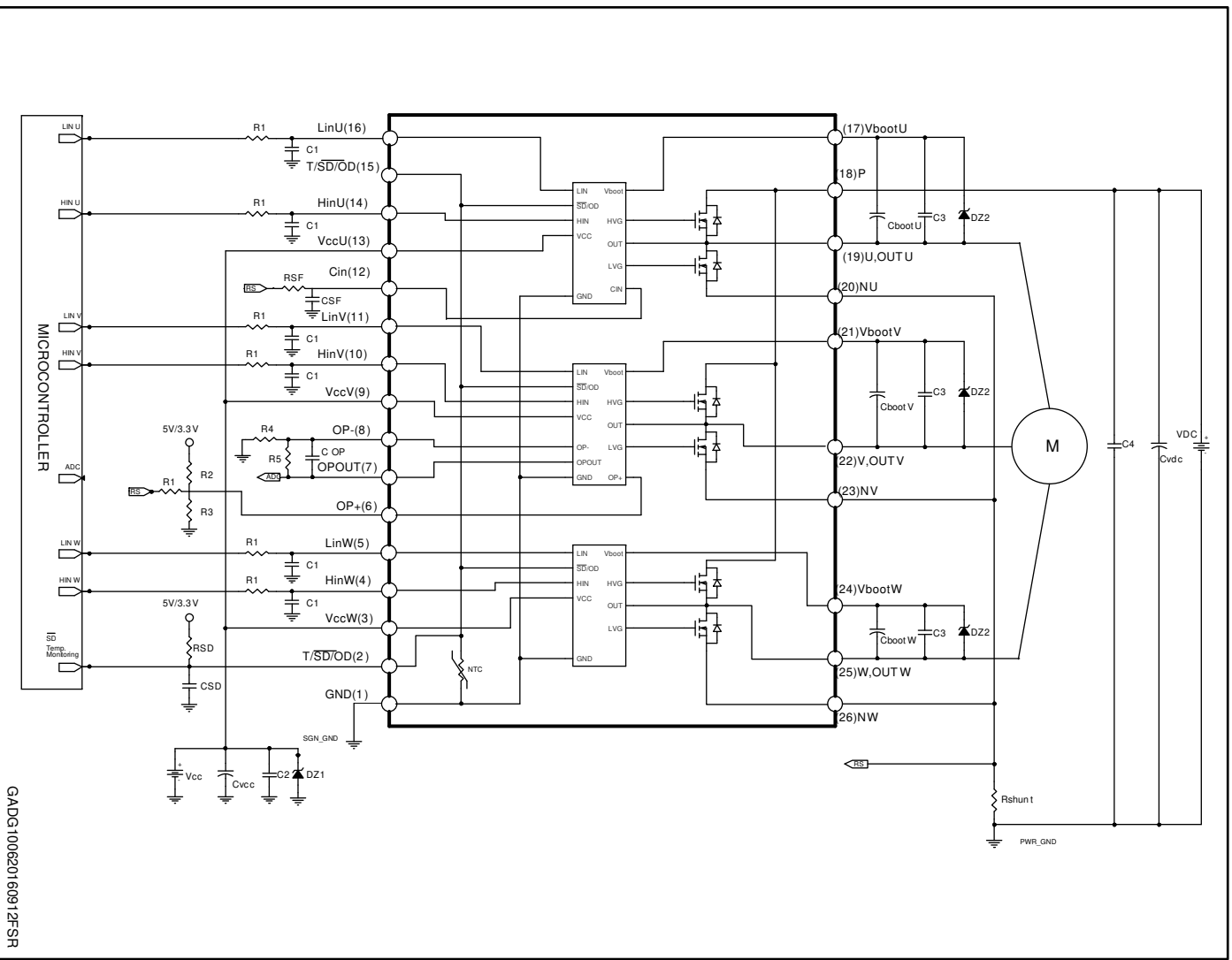

Application designers are free to use a different scheme according to the specifications of the device.

5.1 Guidelines

- Input signals HIN, LIN are active high logic. A 375 k Ω (typ.) pull-down resistor is built-in for each input. To prevent the input signal oscillation, the wiring of each input should be as short as possible and the use of RC filters (R_1 , C_1) on each input signal is suggested. The filters should be with a time constant of about 100 ns and placed as close as possible to the IPM input pins.
- The use of a bypass capacitor C_{VCC} (aluminum or tantalum) can help to reduce the transient circuit demand on the power supply. Besides, to reduce high frequency switching noise distributed on the power lines, a decoupling capacitor C_2 (100 to 220 nF, with low ESR and low ESL) should be placed as close as possible to V_{CC} pin and in parallel with the bypass capacitor.
- The use of RC filter (RSF, CSF) is recommended to avoid protection circuit malfunction. The time constant ($RSF \times CSF$) should be set to 1 μ s and the filter must be placed as close as possible to CIN pin.
- The \overline{SD} is an input/output pin (open-drain type if it is used as output). The CSD capacitor of the filter on \overline{SD} should be fixed no higher than 3.3 nF in order to ensure the \overline{SD} activation time $T_1 \leq 500$ ns; the filter should be placed as close as possible to the \overline{SD} pin.
- The decoupling capacitor C_3 (from 100 to 220 nF, ceramic with low ESR and low ESL), in parallel with each C_{boot} , filters the high frequency disturbance. Both C_{boot} and C_3 (if present) should be placed as close as possible to the U, V, W and V_{boot} pins. Bootstrap negative electrodes should be connected to U, V, W terminals directly and separated from the main output wires.
- To prevent the overvoltage on V_{CC} pin, a Zener diode (Dz1) can be used. Similarly on the V_{boot} pin, a Zener diode (Dz2) can be placed in parallel with each C_{boot} .
- The use of the decoupling capacitor C_4 (100 to 220 nF, with low ESR and low ESL), in parallel with the electrolytic capacitor C_{Vdc} , prevents surge destruction. Both capacitors C_4 and C_{Vdc} should be placed as close as possible to the IPM (C_4 has priority over C_{Vdc}).
- By integrating an application-specific type HVIC inside the module, direct coupling to the MCU terminals without an optocoupler is possible.
- Low inductance shunt resistors should be used for phase leg current sensing.
- In order to avoid malfunctions, the wiring on N pins, the shunt resistor and PWR_GND should be as short as possible.
- The connection of SGN_GND to PWR_GND on one point only (close to the shunt resistor terminal) can help to reduce the impact of power ground fluctuation.

These guidelines are useful for application designs to ensure the specifications of the device. For further details, please refer to the relevant application note.

Table 15: Recommended operating conditions

Symbol	Parameter	Test conditions	Min.	Typ.	Max.	Unit
V_{PN}	Supply voltage	Applied among P-Nu, Nv, Nw		300	400	V
V_{CC}	Control supply voltage	Applied to V_{CC} -GND	13.5	15	18	V
V_{BS}	High-side bias voltage	Applied to V_{BOOTi} - OUT_i for $i = U, V, W$	13		18	V
t_{dead}	Blanking time to prevent arm-short	For each input signal	1			μ s
f_{PWM}	PWM input signal	-40 $^{\circ}$ C < T_c < 100 $^{\circ}$ C -40 $^{\circ}$ C < T_j < 125 $^{\circ}$ C			25	kHz
T_c	Case operation temperature				100	$^{\circ}$ C

6 Package information

In order to meet environmental requirements, ST offers these devices in different grades of ECOPACK® packages, depending on their level of environmental compliance. ECOPACK® specifications, grade definitions and product status are available at: www.st.com. ECOPACK® is an ST trademark.

6.1 NDIP-26L package information

Figure 12: NDIP-26L type C package outline

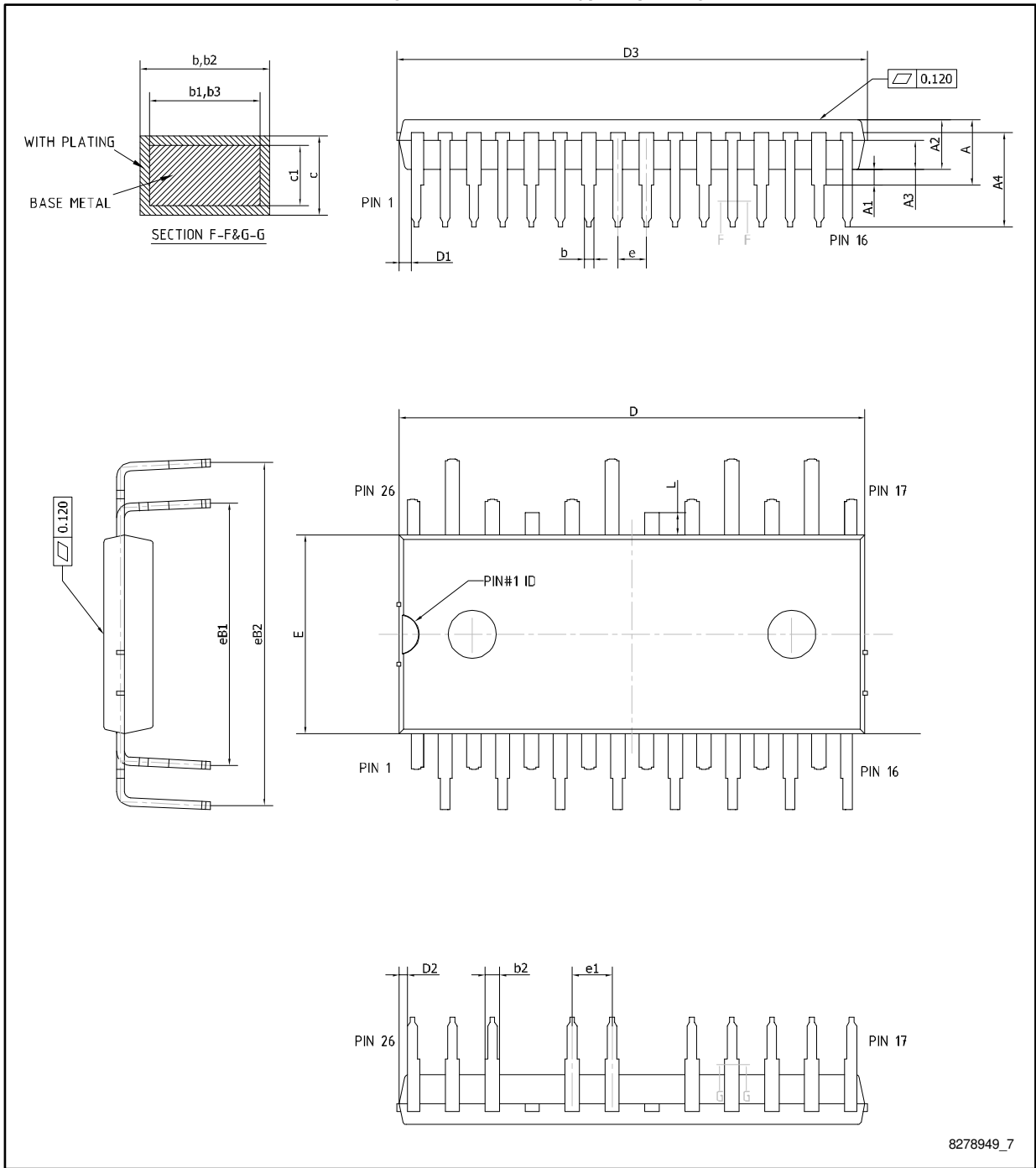

8278949_7

Table 16: NDIP-26L type C mechanical data

Dim.	mm		
	Min.	Typ.	Max.
A			4.40
A1	0.80	1.00	1.20
A2	3.00	3.10	3.20
A3	1.70	1.80	1.90
A4	5.70	5.90	6.10
b	0.53		0.72
b1	0.52	0.60	0.68
b2	0.83		1.02
b3	0.82	0.90	0.98
c	0.46		0.59
c1	0.45	0.50	0.55
D	29.05	29.15	29.25
D1	0.50	0.77	1.00
D2	0.35	0.53	0.70
D3			29.55
E	12.35	12.45	12.55
e	1.70	1.80	1.90
e1	2.40	2.50	2.60
eB1	16.10	16.40	16.70
eB2	21.18	21.48	21.78
L	1.24	1.39	1.54

6.2 NDIP-26L packing information

Figure 13: NDIP-26L tube (dimensions are in mm)

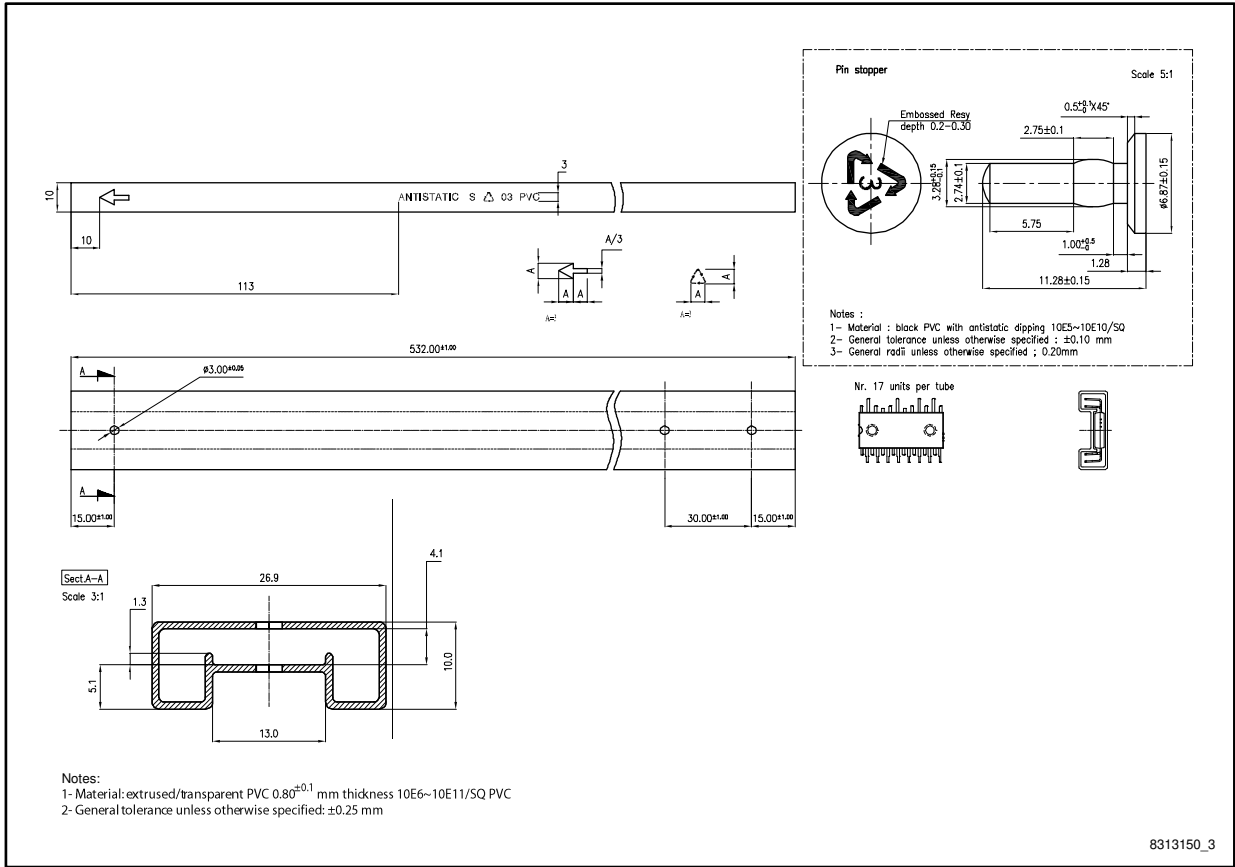

Table 17: Shipping details

Parameter	Value
Base quantity	17 pieces
Bulk quantity	476 pieces

7 Revision history

Table 18: Document revision history

Date	Revision	Changes
03-Feb-2016	1	Initial release.
07-Mar-2016	2	Document status promoted from preliminary to production data. Updated title and features in cover page. Updated <i>Table 7: Inverter part</i> , <i>Figure 3: Switching time test circuit</i> , <i>Figure 4: Switching time definition</i> and <i>Section 6.2: Packing information</i> . Minor text changes.
12-Jul-2016	3	Updated title and features in cover page. Updated <i>Section 3: Electrical characteristics</i> , <i>Figure 11: Application circuit example</i> and <i>Section 5.1: Guidelines</i> . Updated <i>Section 6.1: NDIP-26L package information</i> . Document status changed from preliminary to production data. Minor text changes.
02-Feb-2017	4	Modified <i>Table 15: "Recommended operating conditions"</i> . Minor text changes.

IMPORTANT NOTICE – PLEASE READ CAREFULLY

STMicroelectronics NV and its subsidiaries ("ST") reserve the right to make changes, corrections, enhancements, modifications, and improvements to ST products and/or to this document at any time without notice. Purchasers should obtain the latest relevant information on ST products before placing orders. ST products are sold pursuant to ST's terms and conditions of sale in place at the time of order acknowledgement.

Purchasers are solely responsible for the choice, selection, and use of ST products and ST assumes no liability for application assistance or the design of Purchasers' products.

No license, express or implied, to any intellectual property right is granted by ST herein.

Resale of ST products with provisions different from the information set forth herein shall void any warranty granted by ST for such product.

ST and the ST logo are trademarks of ST. All other product or service names are the property of their respective owners.

Information in this document supersedes and replaces information previously supplied in any prior versions of this document.

© 2017 STMicroelectronics – All rights reserved