



Chipsmall Limited consists of a professional team with an average of over 10 year of expertise in the distribution of electronic components. Based in Hongkong, we have already established firm and mutual-benefit business relationships with customers from,Europe,America and south Asia,supplying obsolete and hard-to-find components to meet their specific needs.

With the principle of “Quality Parts,Customers Priority,Honest Operation,and Considerate Service”,our business mainly focus on the distribution of electronic components. Line cards we deal with include Microchip,ALPS,ROHM,Xilinx,Pulse,ON,Everlight and Freescale. Main products comprise IC,Modules,Potentiometer,IC Socket,Relay,Connector.Our parts cover such applications as commercial,industrial, and automotives areas.

We are looking forward to setting up business relationship with you and hope to provide you with the best service and solution. Let us make a better world for our industry!



## Contact us

Tel: +86-755-8981 8866 Fax: +86-755-8427 6832

Email & Skype: info@chipsmall.com Web: www.chipsmall.com

Address: A1208, Overseas Decoration Building, #122 Zhenhua RD., Futian, Shenzhen, China





# Test Procedure for the STK433-040NGEVB Evaluation Board

Characteristics confirmation

[Connection Diagram]

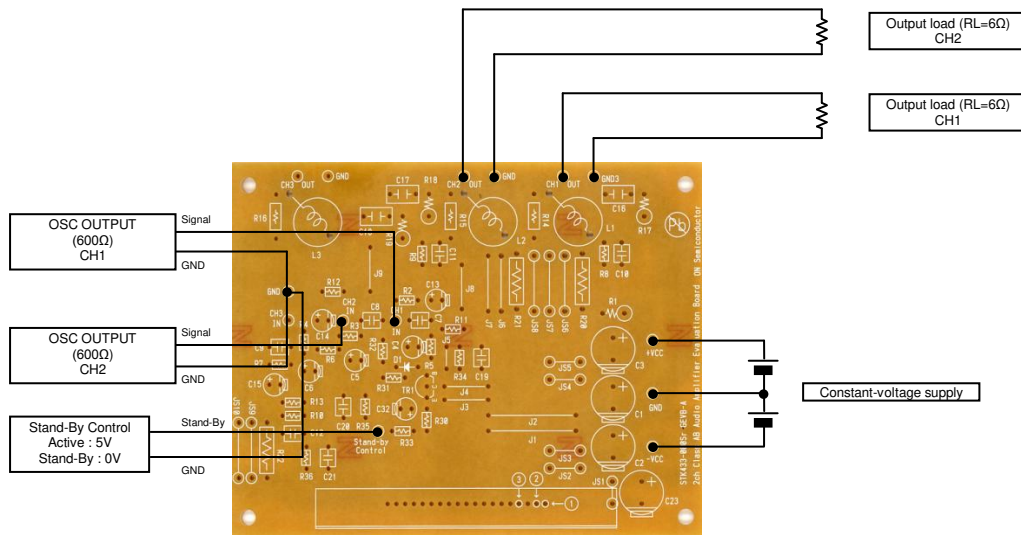

Sound quality confirmation, load short-circuit test, noise examination

[Connection Diagram]

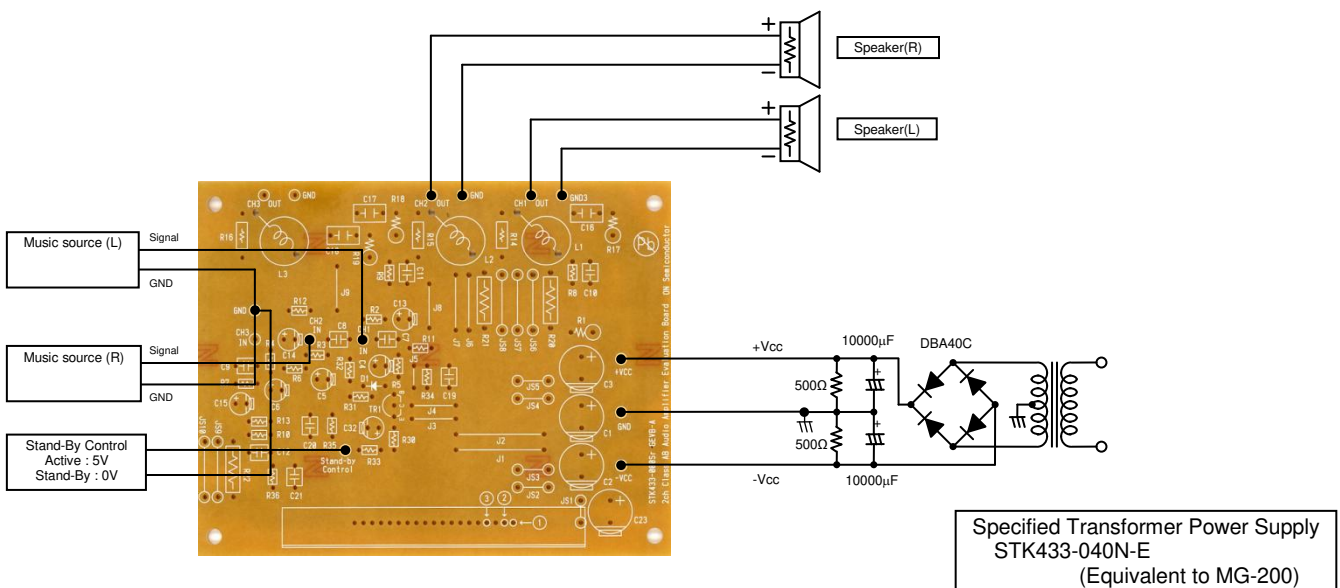





[Required Equipment]

Equipment	Efficiency
Power supply +Vcc	50V-5A
Power supply -Vcc	50V-5A
Power supply Stand-By Control	10V-1A
Load	6Ohm (Non-inductive load )
Measurement	Audio analyzer (Panasonic VP-7723B)

[Supply Voltage]

**+Vcc/-Vcc** : Power Supply for audio power amplifiers

Output 1 (10%/1kHz)	40W x 2 ch
Output 2 (0.4%/2Hz-20kHz)	25W x 2 ch
Recommended operating Vcc (6Ohm)	± 24V

**Stand-By Control (5V)** : Power Supply for Stand-By Control Input  
 5V : Operation / 0V : Stand-by

[Operation Guide]

1. Installation of the heat sink
2. Load Connection
3. Power Supply Connection
4. Stand-By Control Connection
5. Input Connection

Please refer to a thermal design tip for the amplifier.  
 Connect the  $R_L=6\Omega$  (Non-inductive load)  
 Connect the +Vcc/-Vcc (Output off : 0V)  
 Stand-By Control = 0V . Stand-by  
 Connect the Oscillator (Sine wave / Output resistance 600Ω)

6. Power Supply

The gain of the evaluation board is set in 30dB.  
 At first, supply DC voltage to +Vcc and -Vcc.  
 Next, Stand-By Control = 5V . Operation

