



Chipsmall Limited consists of a professional team with an average of over 10 year of expertise in the distribution of electronic components. Based in Hongkong, we have already established firm and mutual-benefit business relationships with customers from,Europe,America and south Asia,supplying obsolete and hard-to-find components to meet their specific needs.

With the principle of “Quality Parts,Customers Priority,Honest Operation,and Considerate Service”,our business mainly focus on the distribution of electronic components. Line cards we deal with include Microchip,ALPS,ROHM,Xilinx,Pulse,ON,Everlight and Freescale. Main products comprise IC,Modules,Potentiometer,IC Socket,Relay,Connector.Our parts cover such applications as commercial,industrial, and automotives areas.

We are looking forward to setting up business relationship with you and hope to provide you with the best service and solution. Let us make a better world for our industry!



Contact us

Tel: +86-755-8981 8866 Fax: +86-755-8427 6832

Email & Skype: info@chipsmall.com Web: www.chipsmall.com

Address: A1208, Overseas Decoration Building, #122 Zhenhua RD., Futian, Shenzhen, China



STK534U363C-E



ON Semiconductor®

<http://onsemi.com>

Advance Information

Inverter IPM for 3-phase Motor Drive

Overview

This “Inverter IPM” is highly integrated device containing all High Voltage (HV) control from HV-DC to 3-phase outputs in a single SIP module (Single-In line Package). Output stage uses IGBT/FRD technology and implements Under Voltage Protection (UVP). Internal Boost diodes are provided for high side gate boost drive.

Function

- Single control power supply due to Internal bootstrap circuit for high side pre-driver circuit
- All control input and status output are at low voltage levels directly compatible with microcontrollers.
- Built-in cross conduction prevention.
- Externally accessible embedded thermistor for substrate temperature measurement

Certification

- UL1557 (File number: E339285).

Specifications

Absolute Maximum Ratings at Tc = 25°C

Parameter	Symbol	Remarks	Ratings	Unit
Supply voltage	V _{CC}	P to U-, V-, W-, surge<500V *1	450	V
Collector-emitter voltage	V _{CE}	P to U, V, W or U, V, W, to U-, V-, W-	600	V
Output current	I _o	P,U-,V-,W-,U,V,W terminal current	±10	A
		P,U-,V-,W-,U,V,W terminal current, Tc=100°C	±5	A
Output peak current	I _{op}	P,U-,V-,W-,U,V,W terminal current, P.W.=1ms	±20	A
Pre-driver voltage	VD1,2,3,4	VB1 to U, VB2 to V, VB3 to W, VDD to VSS *2	20	V
Input signal voltage	V _{IN}	HIN1, 2, 3, LIN1, 2, 3	-0.3 to VDD	V
FLTEN terminal voltage	V _{FLTEN}	FLTEN terminal	-0.3 to VDD	V
Maximum power dissipation	P _d	IGBT per 1 channel	31.2	W
Junction temperature	T _j	IGBT, FRD, Pre-Driver IC	150	°C
Storage temperature	T _{stg}		-40 to +125	°C
Operating case temperature	T _c	IPM case	-20 to +100	°C
Tightening torque		A screw part *3	0.9	Nm
Withstand voltage	V _{is}	50Hz sine wave AC 1 minute *4	2000	VRMS

Reference voltage is “V_{SS}” terminal voltage unless otherwise specified.

*1: Surge voltage developed by the switching operation due to the wiring inductance between P and U-(V-, W-) terminal.

*2: Terminal voltage: VD1=VB1-U, VD2=VB2-V, VD3=VB3-W, VD4=V_{DD}-V_{SS}.

*3: Flatness of the heat-sink should be 0.15mm and below.

*4: Test conditions : AC2500V, 1 second.

Stresses exceeding those listed in the Maximum Ratings table may damage the device. If any of these limits are exceeded, device functionality should not be assumed, damage may occur and reliability may be affected.

This document contains information on a new product. Specifications and information herein are subject to change without notice.

ORDERING INFORMATION

See detailed ordering and shipping information on page 15 of this data sheet.

STK534U363C-E

Electrical Characteristics at T_c = 25°C, VD1, VD2, VD3, VD4 = 15V

Parameter	Symbol	Conditions	Test circuit	MIN	TYP	MAX	Unit
Power output section							
Collector-emitter cut-off current	I _{CE}	V _{CE} = 600V	Fig.1	-	-	100	μA
Bootstrap diode reverse current	I _{R(BD)}	V _{R(BD)} = 600V		-	-	100	μA
Collector to emitter saturation voltage	V _{CE (SAT)}	I _c = 10A, T _j =25°C	Fig.2	-	1.6	2.4	V
		I _c = 5A, T _j =100°C		-	1.4	-	
Diode forward voltage	V _F	I _F = 10A, T _j =25°C	Fig.3	-	1.4	2.1	V
		I _F = 5A, T _j =100°C		-	1.2	-	
Junction to case thermal resistance	θ _{j-c(T)}	IGBT	-	-	-	4	°C /W
	θ _{j-c(D)}	FWD		-	-	6	
Control (Pre-driver) section							
Pre-driver power dissipation	ID	VD1,2,3 = 15V	Fig.4	-	0.08	0.4	mA
		VD4 = 15V		-	1.6	4	
High level Input voltage	V _{in H}	HIN1,HIN2,HIN3,	-	2.5	-	-	V
Low level Input voltage	V _{in L}	LIN1,LIN2,LIN3 to V _{SS}	-	-	-	0.8	V
Logic 1 input leakage current	I _{IN+}	V _{IN} =+3.3V	-	-	100	143	μA
Logic 0 input leakage current	I _{IN-}	V _{IN} =0V	-	-	-	2	μA
FLTEN terminal sink current	I _{oSD}	FAULT:ON / VFLTEN=0.1V	-	-	2	-	mA
FLTEN clearance delay time	FLTCLR	From time fault condition clear	-	1.0	2.0	3.0	ms
FLTEN Threshold	V _{EN+}	V _{EN} rising	-	-	-	2.5	V
	V _{EN-}	V _{EN} falling	-	0.8	-	-	V
ITRIP threshold voltage	V _{ITRIP}	ITRIP(16) to V _{SS} (29)	-	0.44	0.49	0.54	V
ITRIP to shutdown propagation delay	t _{ITRIP}		-	340	550	800	ns
ITRIP blanking time	t _{ITRIPBL}		-	250	350	-	ns
V _{CC} and V _{BS} supply undervoltage protection reset	V _{CCUV+} V _{BSUV+}		-	10.5	11.1	11.7	V
V _{CC} and V _{BS} supply undervoltage protection set	V _{CCUV-} V _{BSUV-}		-	10.3	10.9	11.5	V
V _{CC} and V _{BS} supply undervoltage hysteresis	V _{CCUVH} V _{BSUVH}		-	0.14	0.2	-	V

Reference voltage is “V_{SS}” terminal voltage unless otherwise specified.

Product parametric performance is indicated in the Electrical Characteristics for the listed test conditions, unless otherwise noted. Product performance may not be indicated by the Electrical Characteristics if operated under different conditions.

STK534U363C-E

Electrical Characteristics at $T_c = 25^\circ\text{C}$, $V_{D1}, V_{D2}, V_{D3}, V_{D4} = 15\text{V}$, $V_{CC} = 300\text{V}$, $L = 3.9\text{mH}$

Parameter	Symbol	Conditions	Test circuit	MIN	TYP	MAX	Unit
Switching Character							
Switching time	t ON	I _o = 10A	Fig.5	0.3	0.5	1.2	μs
	t OFF			-	0.6	1.5	
Turn-on switching loss	E _{on}	I _o =5A	Fig.5	-	170	-	μJ
Turn-off switching loss	E _{off}			-	80	-	μJ
Total switching loss	E _{tot}			-	250	-	μJ
Turn-on switching loss	E _{on}	I _o =5A, T _c =100°C	Fig.5	-	200	-	μJ
Turn-off switching loss	E _{off}			-	100	-	μJ
Total switching loss	E _{tot}			-	300	-	μJ
Diode reverse recovery energy	E _{rec}	I _F =5A, P=400V, L=0.5mH,	-	-	17	-	μJ
Diode reverse recovery time	t _{rr}	T _c =100°C	-	-	62	-	ns
Reverse bias safe operating area	RBSOA	I _o =20A, V _{CE} = 450V	-	Full square			-
Short circuit safe operating area	SCSOA	V _{CE} = 400V, T _c =100°C	-	4	-	-	μs
Allowable offset voltage slew rate	dv/dt	Between U,V,W to U-,V-,W-	-	-50	-	50	V/ns

Reference voltage is “VSS” terminal voltage unless otherwise specified.

Product parametric performance is indicated in the Electrical Characteristics for the listed test conditions, unless otherwise noted. Product performance may not be indicated by the Electrical Characteristics if operated under different conditions.

Notes

- When the internal protection circuit operates, a Fault signal is turned ON (When the Fault terminal is low level, Fault signal is ON state : output form is open DRAIN) but the Fault signal does not latch. After protection operation ends, it returns automatically within about typ. 2ms and resumes operation beginning condition. So, after Fault signal detection, set all input signals to OFF (Low) at once. However, the operation of pre-drive power supply low voltage protection (UVLO: with hysteresis about 0.2V) is as follows.

Upper side:

The gate is turned off and will return to regular operation when recovering to the normal voltage, but the latch will continue till the input signal will turn 'low'.

Lower side:

The gate is turned off and will automatically reset when recovering to normal voltage. It does not depend on input signal voltage.

- When assembling the IPM on the heat sink with M3 type screw, tightening torque range is 0.6 Nm to 0.8 Nm.
- When use the over-current protection with external resistor, please set resistance value so that current protection value becomes equal to or less than the double (2 times) of the rating output electric current (I_o).

Module Pin-Out Description

Pin	Name	Description
1	VB3	High Side Floating Supply Voltage 3
2	W, VS3	Output 3 - High Side Floating Supply Offset Voltage
3	-	Without pin
4	-	Without pin
5	VB2	High Side Floating Supply voltage 2
6	V,VS2	Output 2 - High Side Floating Supply Offset Voltage
7	-	Without pin
8	-	Without pin
9	VB1	High Side Floating Supply voltage 1
10	U,VS1	Output 1 - High Side Floating Supply Offset Voltage
11	-	Without pin
12	-	Without pin
13	P	Positive Bus Input Voltage
14	-	Without pin
15	-	Without pin
16	ITRIP	Current protection pin
17	U-	Low Side Emitter Connection - Phase U
18	FLTEN	Enable input / Fault output
19	V-	Low Side Emitter Connection - Phase V
20	HIN1	Logic Input High Side Gate Driver - Phase U
21	W-	Low Side Emitter Connection - Phase W
22	HIN2	Logic Input High Side Gate Driver - Phase V
23	HIN3	Logic Input High Side Gate Driver - Phase W
24	LIN1	Logic Input Low Side Gate Driver - Phase U
25	LIN2	Logic Input Low Side Gate Driver - Phase V
26	LIN3	Logic Input Low Side Gate Driver - Phase W
27	TH	Thermistor output
28	VDD	+15V Main Supply
29	VSS	Negative Main Supply

Equivalent Block Diagram

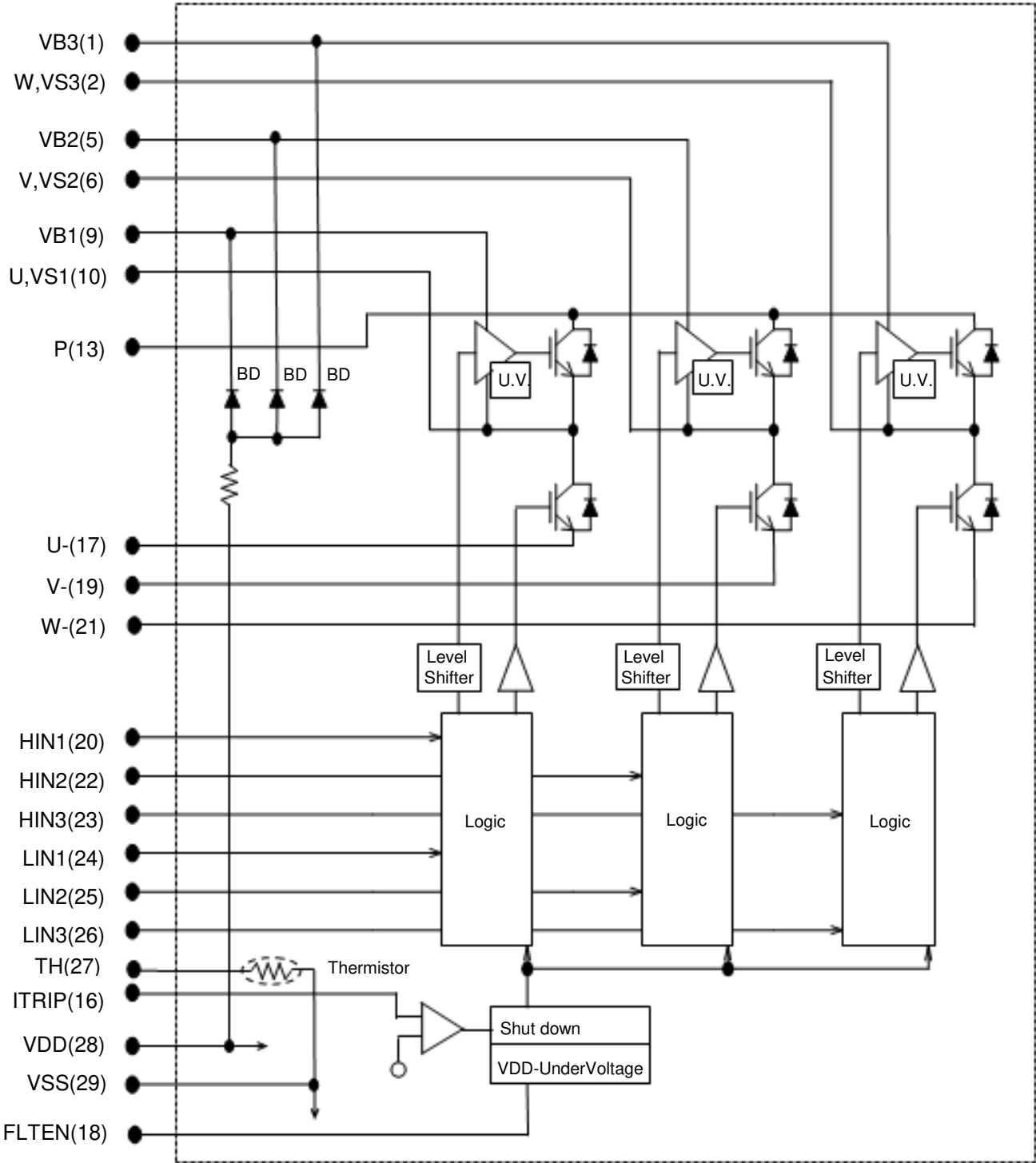

Test Circuit

(The tested phase : U+ shows the upper side of the U phase and U- shows the lower side of the U phase.)

■ ICE / IR(BD)

	U+	V+	W+	U-	V-	W-
M	13	13	13	10	6	2
N	10	6	2	17	19	21

	U(BD)	V(BD)	W(BD)
M	9	5	1
N	29	29	29

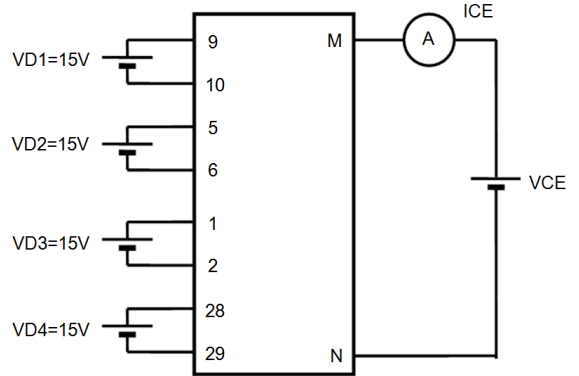

Fig.1

■ VCE(SAT) (Test by pulse)

	U+	V+	W+	U-	V-	W-
M	13	13	13	10	6	2
N	10	6	2	17	19	21
m	20	22	23	24	25	26

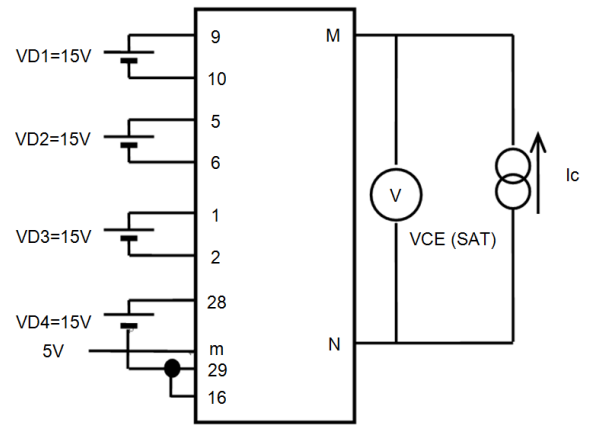

Fig.2

■ VF (Test by pulse)

	U+	V+	W+	U-	V-	W-
M	13	13	13	10	6	2
N	10	6	2	17	19	21

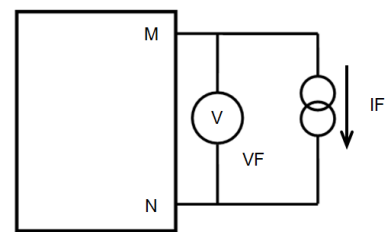

Fig.3

■ ID

	VD1	VD2	VD3	VD4
M	9	5	1	28
N	10	6	2	29

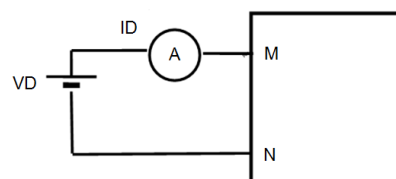

Fig.4

■ Switching time (The circuit is a representative example of the lower side U phase.)

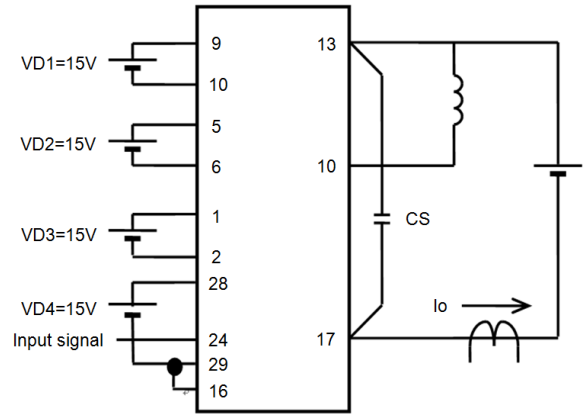
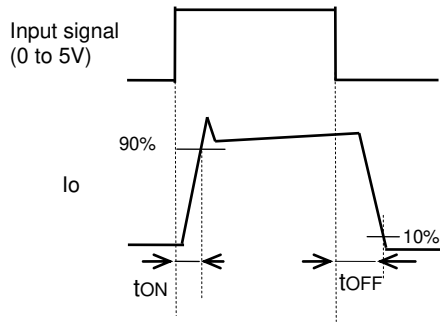

Fig.5

Input / Output Timing Chart

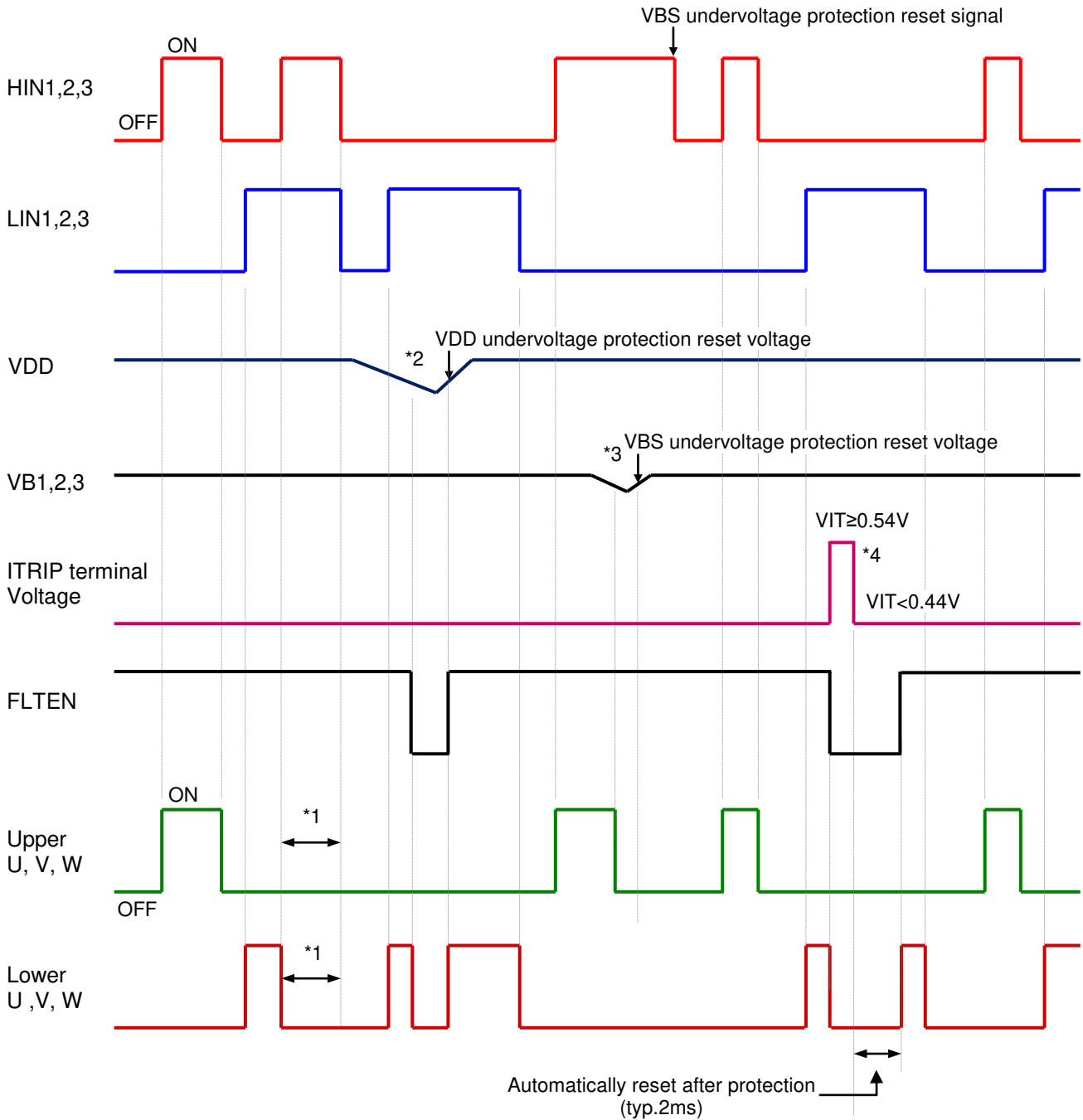
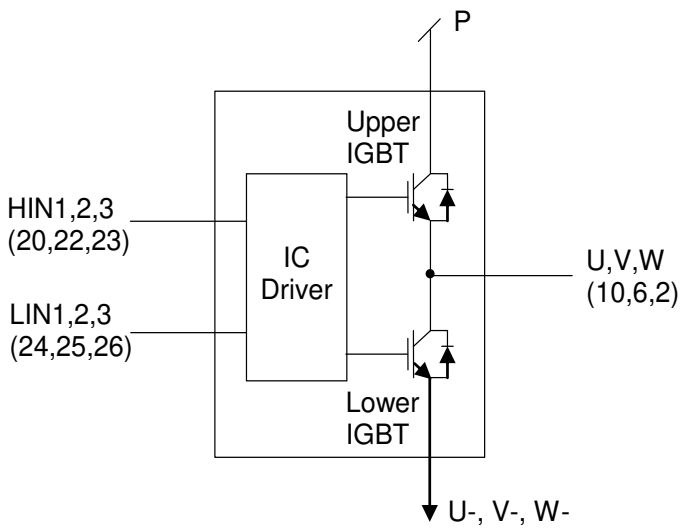

Fig. 6

Notes

- *1 shows the prevention of shoot-thru via control logic, however, more dead time must be added to account for switching delay externally.
- *2 when V_{DD} decreases all gate output signals will go low and cut off all 6 IGBT outputs. When V_{DD} rises the operation will resume immediately.
- *3 when the upper side voltage at VB1, VB2 and VB3 drops only the corresponding upper side output is turned off. The outputs return to normal operation immediately after the upper side gate voltage rises.
- *4 when V_{ITRIP} exceeds threshold all IGBT's are turned off and normal operation resumes 2ms (typ) after over current condition is removed.

Logic level table



INPUT			OUTPUT			
HIN	LIN	Itrip	Upper IGBT	Lower IGBT	U,V,W	FLTEN
H	L	L	ON	OFF	P	OFF
L	H	L	OFF	ON	U-,V-,W-	OFF
L	L	L	OFF	OFF	High Impedance	OFF
H	H	L	OFF	OFF	High Impedance	OFF
X	X	H	OFF	OFF	High Impedance	ON

Fig. 7

Sample Application Circuit

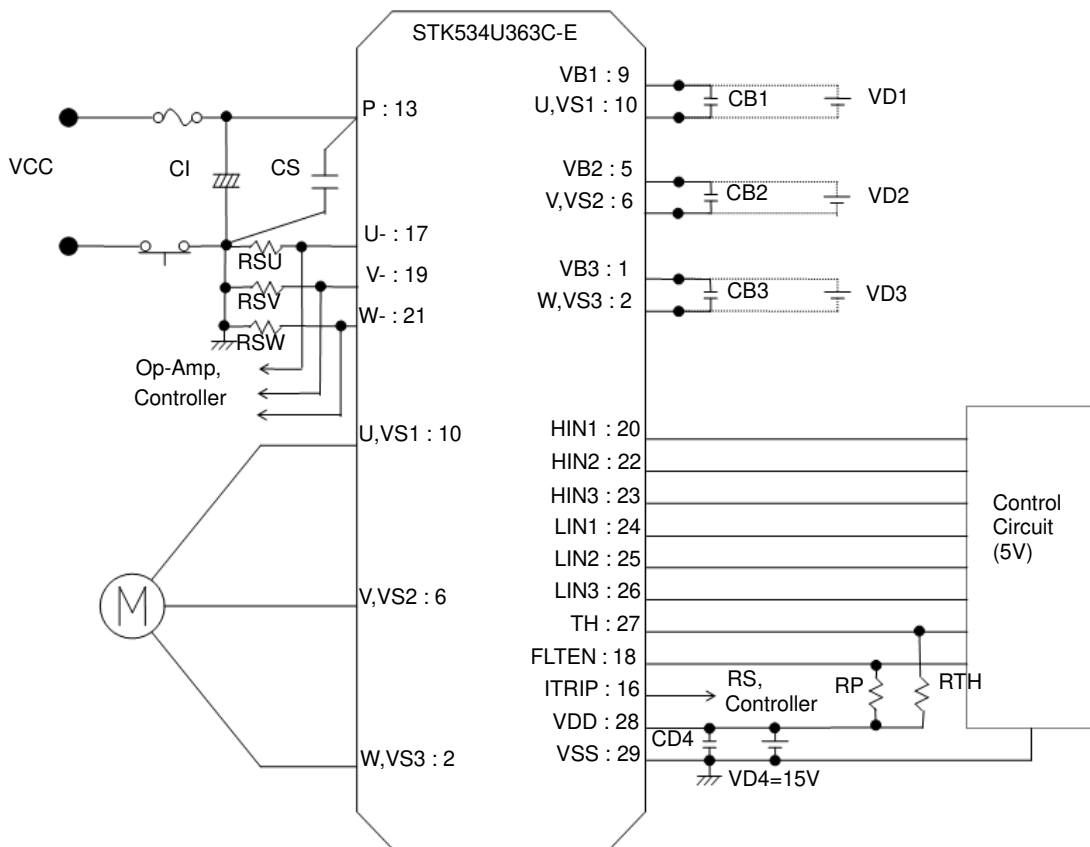

Fig.8

Recommended Operating Condition

Item	Symbol	Conditions	Min.	Typ.	Max.	Unit
Supply voltage	V_{CC}	P to U-(V-,W-)	0	280	450	V
Pre-driver supply voltage	VD1,2,3	VB1 to U,VB2 to V,VB3 to W	12.5	15	17.5	V
	VD4	V_{DD} to V_{SS} *1	13.5	15	16.5	
ON-state input voltage	$V_{IN(ON)}$	HIN1,HIN2,HIN3,	3.0	-	5.0	V
OFF-state input voltage	$V_{IN(OFF)}$	LIN1,LIN2,LIN3	0	-	0.3	
PWM frequency	fPWM		1	-	20	kHz
Dead time	DT	Turn-off to turn-on (external)	1	-	-	μ s
Allowable input pulse width	PWIN	ON and OFF	1	-	-	μ s
Tightening torque		'M3' type screw	0.6	-	0.8	Nm

*1 Pre-drive power supply ($VD4=15\pm 1.5V$) must have the capacity of $I_o=20mA$ (DC), 0.5A (Peak).

Functional operation above the stresses listed in the Recommended Operating Ranges is not implied. Extended exposure to stresses beyond the Recommended Operating Ranges limits may affect device reliability.

Usage Precaution

1. This IPM includes bootstrap diode and resistors. Therefore, by adding a capacitor “CB”, a high side drive voltage is generated; each phase requires an individual bootstrap capacitor. The recommended value of CB is in the range of 1 to 47 μ F, however this value needs to be verified prior to production. If selecting the capacitance more than 47 μ F (\pm 20%), connect a resistor (about 20 Ω) in series between each 3-phase upper side power supply terminals (VB1,2,3) and each bootstrap capacitor.
When not using the bootstrap circuit, each upper side pre-drive power supply requires an external independent power supply.
2. It is essential that wiring length between terminals in the snubber circuit be kept as short as possible to reduce the effect of surge voltages. Recommended value of “CS” is in the range of 0.1 to 10 μ F.
3. “FLTEN” (Pin 18) is open Drain (Active Low). This terminal serves as the shut down function of the built-in pre-driver. (When the terminal voltage is above 3V, normalcy works, and it is shut down when it is equal to or less than 0.8V.) Please make pulling up outside so that “FLTEN” terminal voltages become more than 3V. When the pull up voltage (VP) is at 5V, pull up resistor (RP) recommended more than 6.8k Ω , and in case of VP=15V, RP recommended more than 20k Ω .
4. Inside the IPM, a thermistor used as the temperature monitor for internal substrate is connected between VSS terminal and TH terminal, therefore, an external pull up resistor connected between the TH terminal and an external power supply should be used. The temperature monitor example application is as follows, please refer the Fig.9, and Fig.10 below.
5. Pull down resistor of 33k Ω is provided internally at the signal input terminals. An external resistor of 2.2k to 3.3k Ω should be added to reduce the influence of external wiring noise.
6. The over-current protection feature is not intended to protect in exceptional fault condition. An external fuse is recommended for safety.
7. “ITRIP” (Pin 16) is the input terminal of the built-in comparator. When VITRIP exceeds threshold all IGBT's are turned off and normal operation resumes 2ms (typ) after over current condition is removed. Therefore, please do the protection movement detection of all input signals in OFF (LOW) promptly afterward.
8. When input pulse width is less than 1.0 μ s, an output may not react to the pulse. (Both ON signal and OFF signal)

The characteristic of thermistor

Parameter	Symbol	Condition	Min	Typ.	Max	Unit
Resistance	R_{25}	$T = 25^{\circ}\text{C}$	97	100	103	k Ω
Resistance	R_{125}	$T = 125^{\circ}\text{C}$	2.27	2.52	2.80	k Ω
B-Constant(25-50°C)	B		4165	4250	4335	K
Temperature Range			-40		+125	$^{\circ}\text{C}$

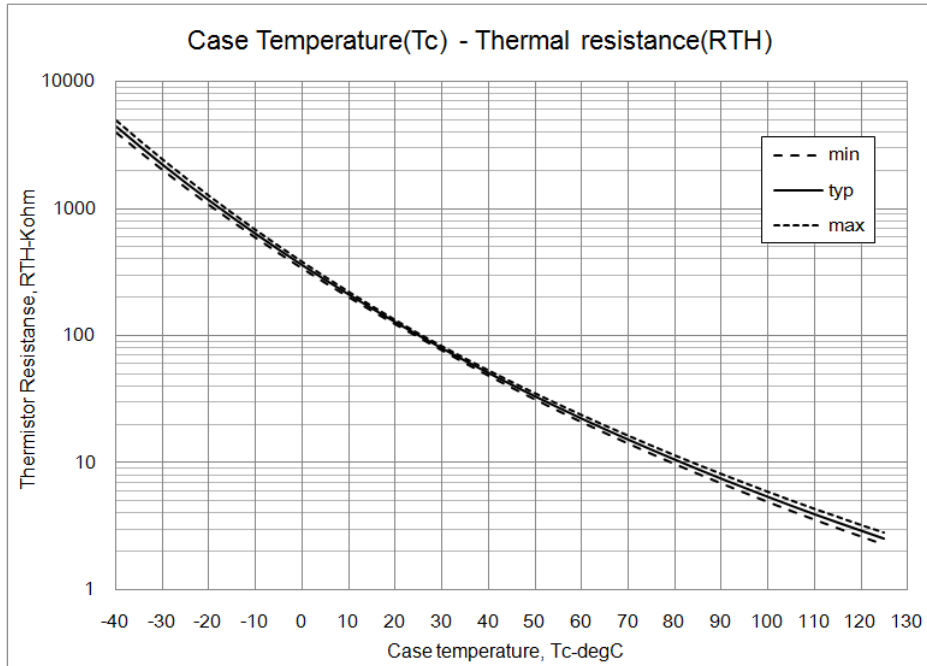

Fig.9

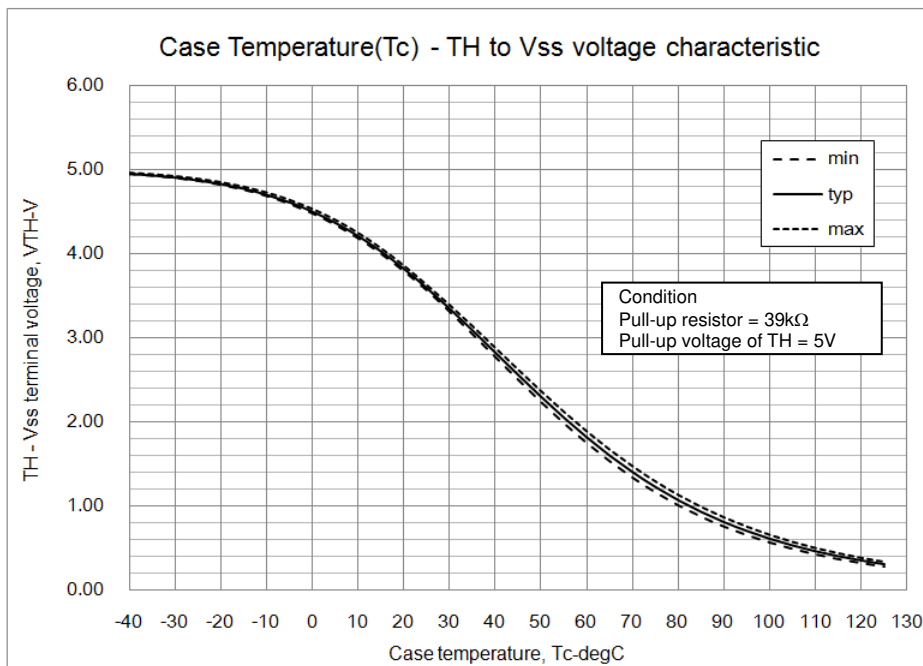

Fig.10

The characteristic of PWM switching frequency

Maximum sinusoidal phase current as function of switching frequency at $T_c=100^{\circ}\text{C}$, $V_{CC}=300\text{V}$

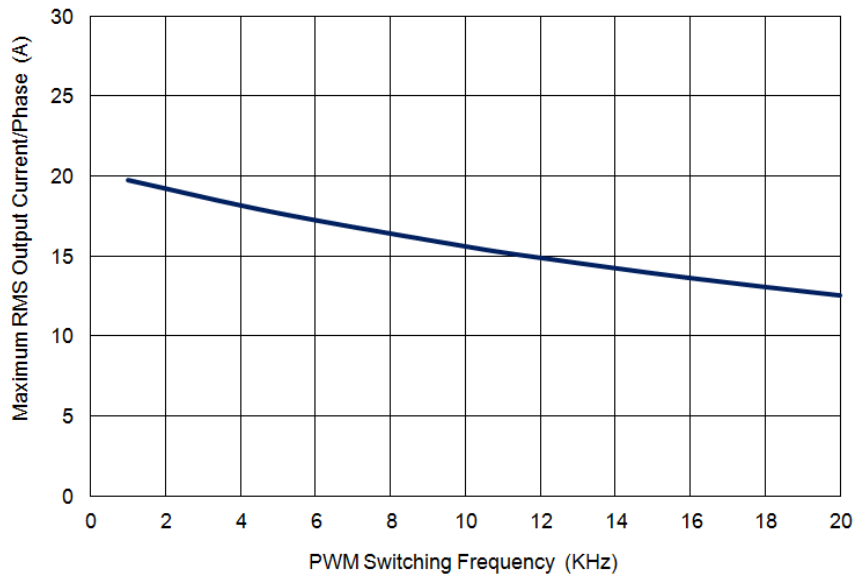

Fig.11

CB capacitor value calculation for bootstrap circuit

Calculate condition

Item	Symbol	Value	Unit
Upper side power supply.	VBS	15	V
Total gate charge of output power IGBT at 15V.	Qg	89	nC
Upper side power supply low voltage protection.	UVLO	12	V
Upper side power dissipation.	IDMAX	400	μA
ON time required for CB voltage to fall from 15V to UVLO	TONMAX	-	s

Capacitance calculation formula

Tonmax is upper arm maximum on time equal the time when the CB voltage falls from 15V to the upper limit of Low voltage protection level.

“ton-maximum” of upper side is the time that CB decreases 15V to the maximum low voltage protection of the upper side (12V).

Thus, CB is calculated by the following formula.

$$VBS * CB - Qg - IDMAX * TONMAX = UVLO * CB$$

$$CB = (Qg + IDMAX * TONMAX) / (VBS - UVLO)$$

The relationship between tonmax and CB becomes as follows. CB is recommended to be approximately 3 times the value calculated above. The recommended value of Cb is in the range of 1 to 47μF, however, the value needs to be verified prior to production.

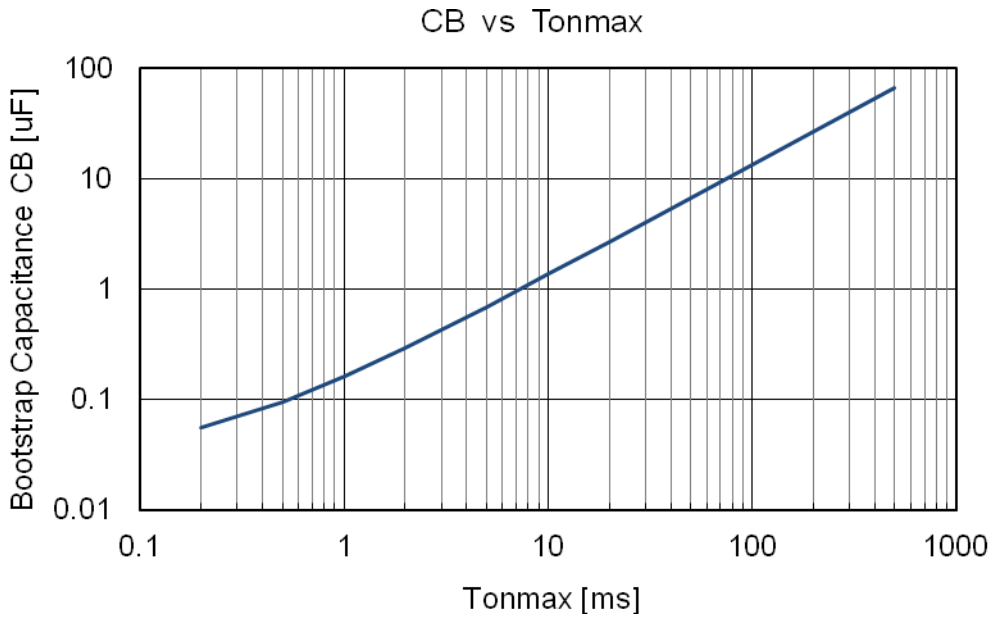

Fig.12 TONMAX vs CB characteristic

STK534U363C-E

ORDERING INFORMATION

Device	Package	Shipping (Qty / Packing)
STK534U363C-E	SIP29 44x26.5 (Pb-Free)	11 / Tube

Package Outline Diagram

Product Name STK534U363C-E

missing pin : 3,4,7,8,11,12,14,15

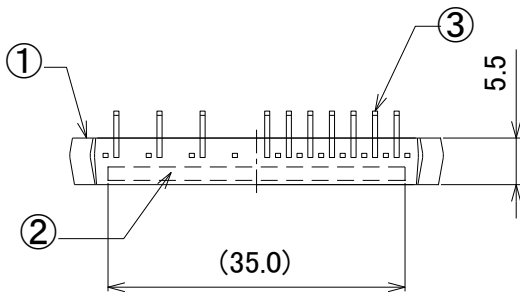
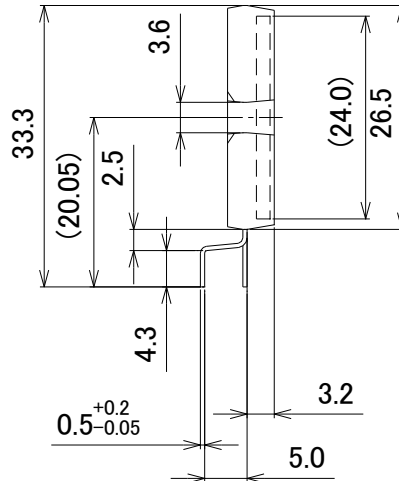
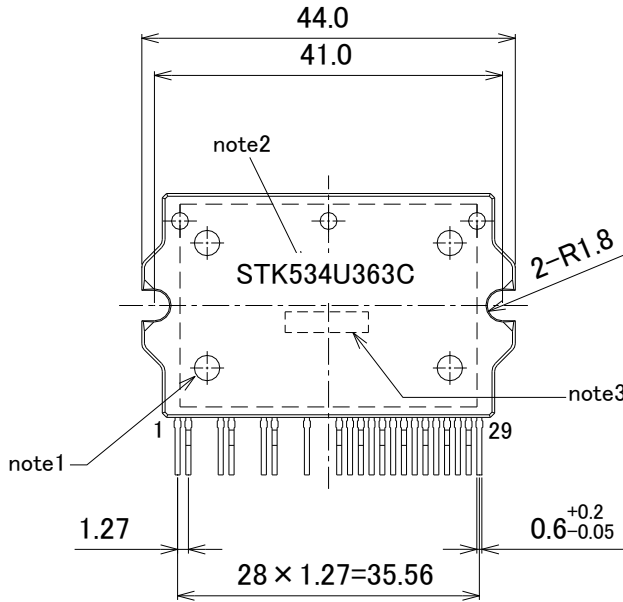

note1 : Mark of mirror surface for No.1 pin identification.

note2: The form of a character in this drawing differs from that of H-IC.

note3: This indicates the lot code.
The form of a character in this drawing differs from that of H-IC.

Unit	mm	
Tolerance	±0.5	
Don't scale this drawing.		
Control No.		

No.	Part Name	Material	Treatment
①	Case	EPOXY	
②	Substrate	IMST Substrate	
③	Lead Frame	Cu	Sn

Date	Revision	In charge	Approval

ON Semiconductor and the ON logo are registered trademarks of Semiconductor Components Industries, LLC (SCILLC) or its subsidiaries in the United States and/or other countries. SCILLC owns the rights to a number of patents, trademarks, copyrights, trade secrets, and other intellectual property. A listing of SCILLC's product/patent coverage may be accessed at www.onsemi.com/site/pdf/Patent-Marking.pdf. SCILLC reserves the right to make changes without further notice to any products herein. SCILLC makes no warranty, representation or guarantee regarding the suitability of its products for any particular purpose, nor does SCILLC assume any liability arising out of the application or use of any product or circuit, and specifically disclaims any and all liability, including without limitation special, consequential or incidental damages. "Typical" parameters which may be provided in SCILLC data sheets and/or specifications can and do vary in different applications and actual performance may vary over time. All operating parameters, including "Typicals" must be validated for each customer application by customer's technical experts. SCILLC does not convey any license under its patent rights nor the rights of others. SCILLC products are not designed, intended, or authorized for use as components in systems intended for surgical implant into the body, or other applications intended to support or sustain life, or for any other application in which the failure of the SCILLC product could create a situation where personal injury or death may occur. Should Buyer purchase or use SCILLC products for any such unintended or unauthorized application, Buyer shall indemnify and hold SCILLC and its officers, employees, subsidiaries, affiliates, and distributors harmless against all claims, costs, damages, and expenses, and reasonable attorney fees arising out of, directly or indirectly, any claim of personal injury or death associated with such unintended or unauthorized use, even if such claim alleges that SCILLC was negligent regarding the design or manufacture of the part. SCILLC is an Equal Opportunity/Affirmative Action Employer. This literature is subject to all applicable copyright laws and is not for resale in any manner.